



---

# **Universidad de Valladolid**

**Escuela Técnica Superior  
de Ingenierías Agrarias**

U.D. de Hidráulica e Hidrología

TESIS DOCTORAL:

## **MODELIZACIÓN HIDRÁULICA DE PASOS PARA PECES ANTE DIFERENTES ESCENARIOS HIDRODINÁMICOS**

Presentada por Juan Francisco Fuentes-Pérez para optar  
al grado de doctor por la Universidad de Valladolid

Directores:

Dr. Ing. Francisco Javier Sanz Ronda

Dr. Ing. Andrés Martínez de Azagra Paredes





---

# **Universidad de Valladolid**

**Escuela Técnica Superior  
de Ingenierías Agrarias**

U.D. de Hidráulica e Hidrología

DOCTORAL THESIS:

## **HYDRAULIC MODELING OF FISHWAYS UNDER VARIABLE HYDRODYNAMIC SCENARIOS**

Submitted for the doctoral degree at Universidad de  
Valladolid by Juan Francisco Fuentes-Pérez

Supervisors:

Dr. Ing. Francisco Javier Sanz Ronda

Dr. Ing. Andrés Martínez de Azagra Paredes



# Table of Contents

Abstract .....	5
List of original articles .....	9
Thesis outline .....	13
Introduction.....	17
River regulation, a need with consequences .....	17
Fishways as a solution to the impacts on fish migration .....	18
Fishways: Problems, unknowns and challenges .....	21
Objectives.....	27
Material and Methods.....	31
Brief theoretical background .....	31
Discharge equations .....	31
Study cases .....	32
Field cases.....	32
Literature review .....	34
Experimental arrangement .....	34
Data fitting and validation.....	35
Chapter 1. Modelling water depth distribution in vertical slot fishways under uniform and non-uniform scenarios.....	39
Chapter 2. Non-uniform hydraulic behavior of pool-weir fishways: A tool to optimize its design and performance.....	51
Chapter 3. Villemonte’s approach: A general method for modelling uniform and non-uniform performance in stepped fishways .....	71
General conclusions .....	95
Fishway performance.....	95
Fishway design .....	95

Fishway retrofitting .....	96
Fishway assessment .....	96
Future Work .....	101
General acknowledgements.....	105
References.....	109
Annex 1. Abstract in Spanish.....	121
Annex 2. Supplementary material of chapter 3.....	125
Annex 3. List of articles included in the compilation thesis.....	141
Annex 4. Declaration of co-authors .....	145



# **Abstract**





## Abstract

Many fish species require to move along rivers to complete their life cycles. Therefore, they are one of the animal groups most affected by the intensive use that humans make from rivers. Among all the impacts, the installation of transversal obstacles to the river is one of the most notable alterations affecting fish movements.

The best solution to recover the free movement of fish is to eliminate the obstacles. However, their social benefits make inviable their removal and often, the only way to restore the longitudinal connectivity is by building fish passes or fishways.

There are many types of fish passes, nevertheless, due to their versatility and ability to deal with a wide range of different types of obstacles, stepped fishways are the most common alternative. Despite their attractiveness to enable the free movement of fish, stepped fishways are sensitive to the natural variability of rivers and their performance can be easily altered by the variable boundary conditions of rivers.

This thesis is a systematic study of the effects of variable boundary conditions in stepped fishways. To do this, the hydraulics of different types and subtypes of fishways are studied, taking into account the most extended calculation methodologies, defining their limitations and proposing new calculation methods. Field study cases under different boundary conditions together with cases from specialized references are considered, resulting in a general methodology for the mean water level modelling of stepped fishway.

The developed methodology allows to consider the natural variability of rivers in fishway design projects which will ensure the correct performance during the whole hydrological period and the performance optimization of those fishways already constructed. Likewise, it allows to consider variability of boundary conditions in fishway assessments, which will produce more relevant result and conclusions in those studies carried out over a long-time period subject hydrological variability.





# List of original articles



## List of original articles

This thesis is based on three original works, which constitute the main body of the thesis. All of them have been published in different indexed international journals. The author of the thesis has been the first author of the three articles, responsible of proposing the initial idea, planning and conducting experiments, designing the methodology, analyzing the data, discussing the results and writing the papers. Author order, title of the publication and journal information are presented below:

- 1) Fuentes-Pérez, J.F., Sanz-Ronda, F.J., Martínez de Azagra Paredes, A., García-Vega, A., 2014. Modelling Water-Depth Distribution in Vertical-Slot Fishways under Uniform and Non-Uniform Scenarios. *Journal of Hydraulic Engineering*. 140, 6014016. doi: 10.1061/(ASCE)HY.1943-7900.0000923.  
Journal metrics: Impact factor (JCR): 2.183 (2016); 2.144 (5-years). Quartile (JCR): Q1, Rank 29/125 in Engineering, Civil; Q2, Rank 35/130 in Engineering, Mechanical; Q2, Rank 25/88 in Water Resources.
- 2) Fuentes-Pérez, J.F., Sanz-Ronda, F.J., Martínez de Azagra, A., García-Vega, A., 2016. Non-uniform hydraulic behavior of pool-weir fishways: a tool to optimize its design and performance. *Ecological Engineering* 86, 5–12. doi: 10.1016/j.ecoleng.2015.10.021.  
Journal metrics: Impact factor (JCR): 2.914 (2016); 3.422 (5-years). Quartile (JCR): Q2, Rank 46/153 in Ecology; Q2, Rank 20/49 in Engineering, Environmental; Q2, Rank 75/229 in Environmental Sciences.
- 3) Fuentes-Pérez, J.F., García-Vega, A., Sanz-Ronda, F.J., Martínez de Azagra Paredes, A., 2017. Villemonte's approach: validation of a general method for modelling uniform and non-uniform performance in stepped fishways. *Knowledge and Management of Aquatic Ecosystems*. 418, 1–12. doi: 10.1051/kmae/2017013.  
Journal metrics: Impact factor (JCR): 1.217 (2016); 1.131 (5-years). Quartile (JCR): Q3, Rank 26/50 in Fisheries; Q3, Rank 62/105 in Marine & Freshwater Biology.

The author has also contributed as an author and co-author in other journal and conference publications. A complete relation of these works can be found in Google Scholar Citations or in ORCID under the digital identifier [0000-0003-2384-9085](https://orcid.org/0000-0003-2384-9085), among other databases.





# Thesis outline





## Thesis outline

The thesis consists of three articles. All of them are focused on the study of the hydraulic performance of stepped fishways (e.g. vertical slot fishway, pool and weir fishway or step-pool nature-like fishway) under variable boundary conditions likely to occur in natural environments, particularly in Mediterranean regions. The main objective of the thesis is to propose and define a practical and general framework for the calculation and water level modelling of stepped fishways under field conditions, and provide a correct characterization of variability to increase their efficiency.

To achieve this, in the first article of the compendium, the hydraulics of the most extended typology of vertical slot fishway is studied (chapter 1). The main objective of the work is to characterize non-uniform water level profiles and propose new calculation methods able to deal with this performance. Thus, this article creates a basic background for the next chapters presented in the thesis.

The next article further investigates the topic by the systematic study of non-uniform and uniform water level profiles in a fishway of the most common type of stepped fishways, pool and weir fishway (chapter 2). Similar methodological principles as defined in chapter 1 are used to showcase their possible use for pool and weir fishways. Likewise, the utility of considering non-uniformity to improve fishway efficiency is analysed, both in hypothetical and real cases.

Based on the methodological framework defined in previous chapters, the last article of the compendium (chapter 3) proposes, defines and validates a general method for the uniform and non-uniform water level modelling on all types of stepped fishways (vertical slot fishway, pool and weir fishway and step-pool nature-like fishway). For this, previous cases (three fishways) together with other cases studied in the field (five fishways) and cases obtained through a systematic review in specialized literature (twenty-one fishways) are considered. Thus, this last work validates a general method for the water level modelling of stepped fishways under a wide variety of boundary conditions.





# Introduction



# Introduction

## River regulation, a need with consequences

Human settlements have long favoured a location close to water bodies, in particular rivers. This is explained by the fact that rivers could act as natural barriers, be a source of primary resources (water, food and sanitation), be used as natural highways for transportation and, with the correct technology, be used as a source of energy (either mechanical or electrical). Following industrialisation, human beings have developed more efficient ways to exploit and regulate water streams. As a result, our current society depends greatly on freshwater to keep its lifestyle, whether for irrigation, to generate electricity or to fulfil industrial, domestic, and recreational necessities. However, the price of this life style has an undeniable environmental cost.

One of the most notable alterations of river regulation is the installation of cross-sectional structures (e.g. weirs, dams, gauging stations, bridges, etc.) (Figure 1). Depending on the scale and dimensions of these structures, they can produce different impacts, e.g. fragmentation or loss of longitudinal connectivity (Lasne et al., 2007; Branco et al., 2012), geomorphological alterations (Graf, 2006) or, flow and thermal manipulations (García-Vega et al., 2017).



**Figure 1.** Cross sectional structures that may have a negative impact for fish migration: gauging stations, dams, weirs or bridges.

Among all the possible consequences of cross-sectional structures, fragmentation of longitudinal connectivity is presumed to be one of the main ecological issues. This is due to structures acting as transversal barriers that generate physical modifications in the river, the partial or complete isolation of species and communities, disruptions of natural movements, the modification of abundance of fauna and, in the worst case scenario, the disappearance of some species (Larinier, 2001; Lucas et al., 2001).

Fragmentation specially affects to fish fauna, as in many cases they require different environments to complete their life cycles (Porcher and Travade, 2002). For instance, in the Iberian Peninsula some species have been recognized as disappeared in many streams (e.g. sturgeon, eel, shad, salmon or lampreys) and, in other cases, some species have been classified as vulnerable (e.g. some species of barbels and nases) (Elvira et al., 1998; Martínez de Azagra, 1999; Sanz-Ronda et al., 2013; IUCN, 2017).

Due to this major problem, European, national and regional legislations have been developed to guarantee the movements of fish along rivers by retrofitting for this purpose any structure that prevents or limits them (European Commission, 2000; Spanish Water Law, 2001). This seems a basic premise to reduce the impact generated by the use we make from rivers and, in the case of hydroelectric plants, to promote them as a source of clean and sustainable energy.

## **Fishways as a solution to the impacts on fish migration**

Installation of fishways is one of the most widely adopted solution to solve the impact caused by transversal river structures to fish fauna (Bunt et al., 2012, 2016). Fishways (also known as fish passages, fish passes or fish ladders) are structures that facilitate or allow the passage of fish from one side to the other in transversal obstacles to the river (Martínez de Azagra, 1999). There are many type of fishways (e.g. stepped fishways, block ramps, Denil or baffle fishways, etc.) (Figure 2).



**Figure 2.** Example of different types of fish passage structures. a) Pool and weir fishway (submerged notch and orifice). b) Double vertical slot fishway. c) Step-pool nature-like fishway. d) Nature-like block ramp.

The most common type and most studied fish passes are the stepped fishways (Clay, 1995; Martínez de Azagra, 1999; FAO/DVWK, 2002; Fuentes-Pérez et al., 2017a). This fishway type consists of a succession of cross-walls in a sloped channel that divide the total height of the obstacle ( $H$ ) in smaller drops ( $\Delta H$ ) in each cross-wall. This ensures that the hydraulic conditions inside are in the range of the physical capacities of fish fauna and, thus, enables their passage.

One of the possible classification of stepped fishways is: vertical slot fishway (VSF) (Rajaratnam et al., 1986; Larinier, 2002a; Fuentes-Pérez et al., 2014), pool and weir fishway (PWF) (Rajaratnam et al., 1988; Larinier, 2002a; Fuentes-Pérez et al., 2016), and step-pool nature-like fishway (SPNF) (FAO/DVWK, 2002; Wang and Hartlieb, 2011)) (Figure 3). Many subtypes and variations of these typologies can be found around the world, nevertheless, in all of them the working principle is similar.

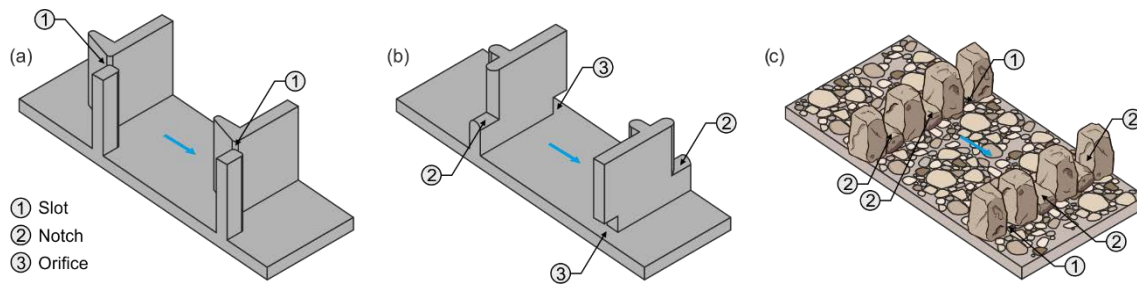

**Figure 3.** Examples of sections of stepped fishways. Each type, (a) Vertical slot fishway, (b) Pool and weir fishway and (c) Step-pool nature-like fishway, can have different subtypes according to their morphology and connections (Fuentes-Pérez et al., 2017a).

There are well-established guidelines to design fishways (e.g. Clay, 1995; FAO/DVWK, 2002; Larinier, 2002; Martínez de Azagra, 1999; among others). In brief, the design and calculation of these structures, after selecting the location, the target species (that will define the biological constraints), design discharge ( $Q_{fishway}$ ) and water level difference in the obstacle ( $H$ ) (boundary conditions associated to a specific time period, e.g. migration period of the target species), is based on three main steps (Figure 4): 1) design and dimensioning of the regular cross-wall and pool, 2) fish exit adjustment, and 3) fish entrance adjustment.

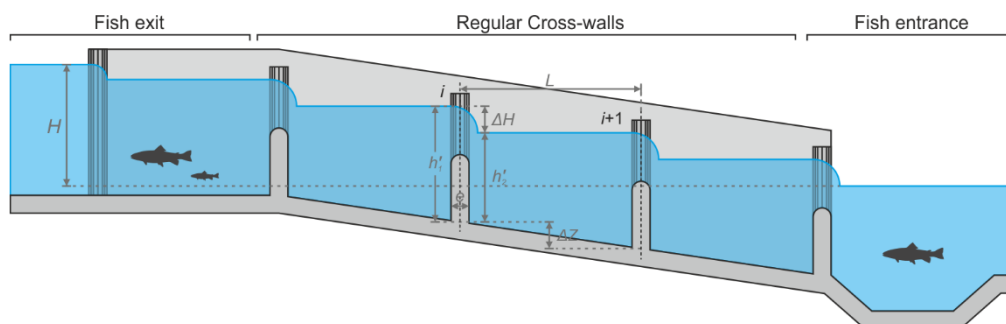

**Figure 4.** Definition of the standard design components in a fishway and variables (Fuentes-Pérez et al. (in prep)).

The design and dimensioning of cross-walls and pools can be achieved using two different sets of equations: 1) discharge equations that define the performance of the connections between pools in the cross-wall (dimensionless relationships (Rajaratnam et al., 1986, 1989; Ead et al., 2004; Yagci, 2010) or classical weir equations (Larinier, 1992; Clay, 1995; Martínez de Azagra, 1999; Boiten and Dommerholt, 2006; Krüger et al., 2010)) and 2) the equations that define the relevant variables for fish fauna, such as volumetric power dissipation ( $VPD$ ) or maximum water velocity ( $V_{max}$ ) (Larinier, 1992; Martínez de Azagra, 1999; FAO/DVWK, 2002).



If the preliminary selection is correctly done (i.e. location, discharge and typology), it is possible to correctly dimension the fishway for the selected boundary conditions with the combinations of both set of equations (if they are correctly defined) and taking into consideration the target fish preferences. However, any error in the assumptions, equations, calculations as well as modification in boundary conditions, may led to a reduction of the functionality of the structure or, in the worst scenario, to a non-working structure.

In the Iberian Peninsula, due to the peculiarity of our fish fauna, considerable efforts have been done in the study of these structures. Among others, it is worth mentioning the works done in VSF by the Civil Engineering School of the University of A Coruña (Spain) together with the Hydraulic Laboratory of the Centre for Studies and Experimentation of Public Works (CEDEX, Spain) (Pena, 2004; Cea et al., 2007; Bermúdez et al., 2010; Puertas et al., 2012; among others) or the work done about VSF and PWF by the researching group of Civil Engineering for Research and Innovation for Sustainability and Forest Research Centre of University of Lisbon (Portugal) (Santos et al., 2012, 2014; Branco et al., 2013; Quaresma et al., 2017; Romão et al., 2017; among others).

## **Fishways: Problems, unknowns and challenges**

Unfortunately, the number of steps involved in the design process and the sensitivity of each one makes the design of fishways a complex problem which is usually oversimplified. The design can be further complicated given the number of unknowns that exists around fishways.

For instance, one of the major issues pointed out in the specialized literature is the number of unknowns regarding the swimming abilities, migration periods, and motivation of many migratory fish species (Bunt et al., 2012; Williams et al., 2012). In these cases, the dimensioning of a specific solution has a high probability of being wrong. Furthermore, due to the different ecological traits of fish species, sometimes, a single solution design for the ensemble can be difficult. In the case of the Iberian Peninsula, it is worth mentioning that in recent years several groups have tried to address this knowledge gap for the most relevant migratory fish species (e.g. Iberian barbel (*Luciobarbus bocagei*), Iberian chub (*Squalius pyrenaicus*) or northern straight-mouth nase (*Pseudochondrostoma duriense*), (Alexandre et al., 2013; Branco et al., 2013; Santos et al., 2013; Sanz-Ronda et al., 2016, 2015c, Silva et al., 2012, 2011; among others).

Even if the target species is well known, the fish will need to find the fishway. This is usually accomplished by situating the fishway correctly (Larinier, 2002b) and providing an adequate flow rate and turbulence profile near or in the entrance. Evidently, the most attractive fishway would take the whole flow of the river (Williams et al., 2012). However, a lower discharge in the fishway will reduce the costs and will allow to exploit more volume of water. Thus, establishing a general criterion to ensure a correct attractivity in the fishway is a rising researching topic (Cooke and Hinch, 2013). To date, the observed attraction efficiencies are very far from the optimal (Bunt et al., 2012, 2016).

If the problem was not complex enough, previous factors usually require a snapshot of the river discharge for their possible analysis, however, the hydrological regime of rivers varies in space and time and, even more, in the Mediterranean regions (Gasith and Resh, 1999). This fact produces dynamic boundary conditions in the fishway that alter the calculated performance. Despite this issue, it is a common practice to disregard the variability by considering constant performance or averaging hydraulic conditions inside them (Puertas et al., 2004; Rajaratnam et al., 1986; Wang et al., 2010; among others).

Fishway hydraulic performance can lead to different water level profiles, that in idealized conditions is manifested as a constant value or a progressive decrement or increment of mean water level distribution (Figure 5(a)). These profiles were named by Rajaratnam et al. (1986) comparing the distribution generated by the mean water depth in pools to the water profiles provided by the Bakhmeteff-Chow method for gradually varied flow water level profile classification (Figure 5(b)), resulting in three water level distributions: 1) uniform profile (U), when  $\Delta H$  is equal to the topographic difference between pools ( $\Delta Z$ ); 2) non-uniform backwater profile (M1), which produces higher mean depth ( $h_0$ ) and smaller drops ( $\Delta H < \Delta Z$ ) in the downstream pools of the fishway; and 3) non-uniform drawdown profile (M2), which contrary, generates lower  $h_0$  and higher drops ( $\Delta H > \Delta Z$ ) in downstream pools.

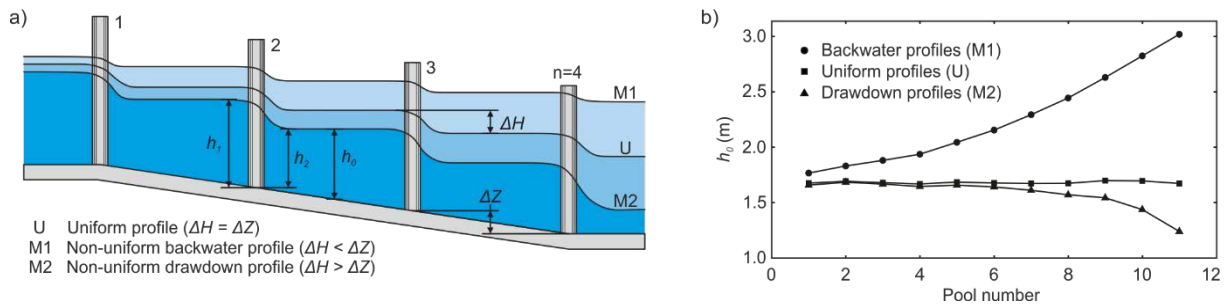

**Figure 5.** Possible water level profiles during uniform and non-uniform performance in a fishway. a) Diagram showing the possible profiles. b) Experimental results of Rajaratnam et al. (1986). (Fuentes-Pérez et al., 2017b).

Despite this phenomenon is well known since first VSF serial studies of Rajaratnam et al. in 1986, some solutions were proposed by Larinier in 2002 and has been widely studied in recent years (Fuentes-Pérez et al., 2014, 2016; Marriner et al., 2016), it is still ignored by the design community and, in most of the cases by the research community (Puertas et al., 2004, 2012; Liu et al., 2006; Bermúdez et al., 2010; Yagci, 2010; Silva et al., 2012b; Santos et al., 2012; Branco et al., 2013; Romão et al., 2017; among many others), regardless its importance and its direct consequences.

As shown, non-uniformity modifies the  $h_0$  and  $\Delta H$  profiles observed in the fishways which may have direct consequences on fishways performance and, therefore efficiency, as spatial distribution and magnitude of velocity and turbulence fields in pools may be altered (Tarrade et al., 2008; Wu et al., 1999). In a fishway global scale M1 profiles may improve the passability due to the lower velocities in the cross-walls or the reduction on the  $VPD$  within the pools, but it may decrease the attractivity due to reduction of velocity in the most downstream cross-walls. In contrast, M2 profiles may led to more attractive situations but may generate too demanding drops to be surpassed or conditions with too high  $VPD$  in downstream pools. In a smaller scale (i.e. pool or fishway scale), the modification of turbulence field in the pool, for instance, may have a direct impact on fish behavior and locomotion (Lupandin, 2005), fish stability (Silva et al., 2012), path selection (Goettel et al., 2015) or energy expenditure (Enders et al., 2005). Therefore, it is possible to estimate fishway efficiency incorrectly when assuming that fishways run only under uniform profiles.

In the same way, fishways are usually designed considering uniform profiles or using equations that have not been evaluated or analyzed under non-uniform conditions. This has direct consequences for fish as fishways are designed considering their burst speed (highest speed

attainable and maintainable for a short period of time) to make the cross-walls surpassable, and a maximum *VPD*, to avoid injuries and disorientation (FAO/DVWK, 2002; Katopodis, 1992; Larinier, 2002b). Therefore, if non-uniform profiles are not considered in the design process, M2 (which increase velocities and drops) or M1 (which may make unlocalizable an appropriate ascending path) profiles may lead to impassable scenarios. Thus, these different performances produced by variations in boundary conditions of the river should be considered in fishway research.

Non-uniformity is gathering importance in recent years, not only because the articles covered by this thesis but also due to the works such as Krüger et al. (2010) or Marriner et al. (2016) about VSFs. Likewise some of the most extended calculation methods (FAO/DVWK, 2002; Larinier, 2002a), by definition, may allow to model at least partly the water level variability in fishways (chapter 1) (Fuentes-Pérez, 2012; Fuentes-Pérez et al., 2014). However, due to the importance of variability there is a need to further study its consequences and its opportunities to increase the efficiencies (chapter 2). In the same way to consider these hydraulic performances in uncontrolled field experiments, a general methodology must be defined (chapter 3). The present thesis tries to cover these shortcomings by the systematic study of stepped fishways performance under a wide variety of boundary conditions and defining, with an incremental research approach, a general method applicable to most popular type of stepped fishways, which can be directly applied to new fishways design in the geometrical range of the studied structures. Therefore, the resultant methodology will allow the consideration of non-uniform profiles and their consequences to new designs and use their prediction to retrofit already built structures, which will be a useful tool for fishway design and evaluation.



# Objectives



# Objectives

The general objective of the present thesis is to define a general framework for the water level modeling under variable boundary conditions in most common types of stepped fishways.

## Specific objectives

- To study and apply the current methodologies for the design of stepped fishways, using real cases subject to hydraulic and constructional variability.
- To compare performance of current methodologies for the design of stepped fishways using the same real case studies.
- To define the limitations of the current design methodologies using real study cases.
- To develop a suitable formulation which considers the variability of boundary conditions in the design of stepped fishways and test their performance in real study cases.
- To compare the developed formulation with the well-established design methodologies using real and laboratory study cases.
- To study the possible limitations of the proposed formulation.
- To provide examples for future applications and continue the development of the defined formulation and calculation framework.







# **Material and Methods**



# Material and Methods

In this section, a general summary of the material and methods used in different chapter is presented. A more detailed description of the specific methodology used in each experiment can be found in the corresponding section of each chapter.

## Brief theoretical background

### Discharge equations

Many equations have been proposed to calculate the discharge and performance of stepped fishways. However, in most of the cases, these are derivations of classical weir-discharge equations (Martínez de Azagra, 1999; Kim, 2001; FAO/DVWK, 2002; Larinier, 2002a; Boiten and Dommerholt, 2006; Santos et al., 2012) or dimensionless relationships (Rajaratnam et al., 1989; Ead et al., 2004; Yagci, 2010).

Taking into account the limitations to model non-uniform profiles of dimensionless relationships (Rajaratnam et al., 1986), classical equations have been adopted in the present study. Nevertheless, for comparison, methods from both approaches have been considered in all the chapters. A summary of alternative calculation methods proposed by specialized literature is presented in S4 Appendix of Chapter 3 (Annex 2 of the present thesis or online at <https://doi.org/10.1051/kmae/2017013>).

During this work, the equation for weirs proposed by Poleni (1717) (Eq. 1) will be principally used to describe the flow ( $Q$ ) through notches (Larinier, 1992; Martínez de Azagra, 1999; FAO/DVWK, 2002) and slots (FAO/DVWK, 2002; Krüger et al., 2010). To explain the  $Q$  through orifices the equation derived from Torricelli's law (Torricelli, 1644) (Eq. 2) will be used (Larinier, 1992; Martínez de Azagra, 1999; FAO/DVWK, 2002; Boiten and Dommerholt, 2006).

$$Q = \frac{2}{3} \cdot C_s \cdot b \cdot h_1^{1.5} \cdot \sqrt{2 \cdot g} \quad 1$$

$$Q = C_o \cdot b \cdot a \cdot \sqrt{2 \cdot g \cdot \Delta H} \quad 2$$

where  $g$  stands for the gravity,  $h_1$  is the water level upstream the cross-wall deducting the sill height ( $p$ ),  $b$  is the width of notches, slots or orifices,  $a$  is the height of the orifice and  $C$  ( $C_s$  and  $C_o$ ) stands for the discharge coefficients.

The discharge equations alone may not be able to characterize correctly the discharge under non-uniform profiles. Thus, this variability should be included in the discharge coefficients by including water level variables able to characterize the hydrodynamic conditions in the structure. The different chapters of the present thesis will analyze deeply the behavior of these coefficients during non-uniform profiles in different stepped fishway configurations.

## Study cases

To consider the variability observed in rivers and define solutions applicable to real cases, fishway installed in field have been considered. In addition, cases from specialized literature have also been considered for comparison and to analyze the achieved accuracy.

### Field cases

All the field cases studied are located in the autonomous community of *Castilla y León*, Duero River basin, in North-Central Spain (Figure 6). The Department of Hydraulics and Hydrology of the University of Valladolid has been involved in the design of all of them. This facilitated the access to the structures and the relation with the owners.

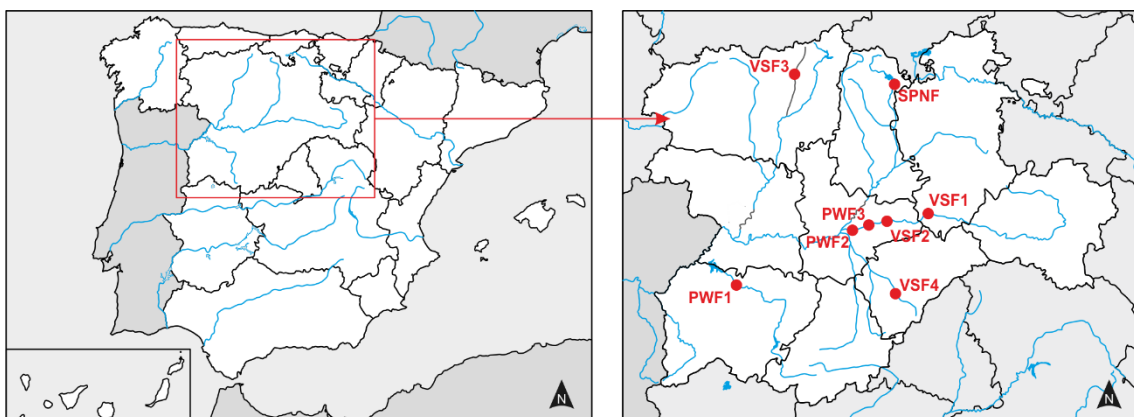

**Figure 6.** Field cases location (Fuentes-Pérez et al., 2017a). Three types of fishways were studied in field: vertical slot fishway (VSF), pool and weir fishway (PWF) and step-pool nature-like fishway (SPNF). Localization coordinates are defined in Annex 2 of the present thesis (or S2 Appendix of chapter 3).

Table 1 summarizes the chapter relation for the field study cases. In chapter 1 only VSFs are considered, analyzing in detail their performance. Similarly, in chapter 2 the performance of PWF is analyzed. The last chapter integrates both typologies and extends the proposed methodology to any type of stepped fishway (e.g. nature-like fishways), taking into consideration field cases as well as different fishway typologies described in the specialized literature.

**Table 1.** Coordinates and chapter relation of studied cases.

Code	Name	Coordinates (UTM WGS84)	Chapter
VSF1	Vadocondes	30T4074608	1,3
VSF2	Peñafiel	30T4524609	1,3
VSF3	Vegas del Condado	30T3074729	3
VSF4	Carracillo	30T4084570	3
PWF1	La Flecha	30T2834539	2,3
PWF2	Sardón de Duero	30T3824608	3
PWF3	Josefina	30T4024609	3
SPNF	Aguilar de Campoo	30T3974736	3

A detailed description of the geometrical characteristics of all the structures considered (Figure 7) can be found in each of the chapters composing the thesis, as well as in Annex 2.



**Figure 7.** Study cases. a) Vadocondes. b) Peñafiel. c) Vegas del Condado. d) Carracillo. e) Sardón de Duero. f) La Flecha. g) Josefina. h) Aguilar de Campoo.

## **Literature review**

In some chapters, data from peer-reviewed scientific studies and grey literature has been considered to test our different hypotheses (c.f. chapter 3). In addition, to compare the proposed solutions a review of most extended methodologies was made. These systematic searches were carried out in Google Scholar as well as Web of Science and Scopus from conception to the submission of different chapters following the PRISMA guidelines (Moher et al., 2009).

## **Experimental arrangement**

The measuring methodology for field cases has been standardized and used in all the different field measurements. Before measuring hydraulic variables, the geometrical parameters of each structure were measured by topographic surveying with a total station Leica TC307 to a millimetric resolution. Smaller details, such as orifice, notch and slot dimensions were measured by means of metal rulers to the same resolution level.

The flow rate was controlled by the gates located upstream the structures and, in cases where was possible, boundary conditions were artificially modified in the fishways to increase the number of studied cases. Flow rate was measured by chemical gaging using Rhodamine WT as tracer. This method consists on the constant adding of a known discharge of chemical solution of Rhodamine WT in the fishway (using a Mariotte's bottle). The flow rate is then calculated by measuring the Rhodamine WT dilution after a good mixing distance (Kilpatrick and Cobb, 1985). This type of experiment was replicated for a minimum of three times for each case.

Water levels were measured to a millimetric precision in each of the pools, by means of metal rulers of a resolution of 0.5 mm installed downstream the cross-walls where water surface was found more stable, opposite to notches or slots. Water level oscillations were recorded for 8 s using a camera (Canon EOS 600D) with a sampling rate of 25 Hz. After, the recorded frames were translated into a water level data string, monitoring the cumulative mean values until the oscillation of the mean value were lower than millimetric (Figure 8). For SPNF, chapter 3, due to the absence of reference points for the metal rulers, as the fishway was a nature-like fishway, water levels were measured until a stable mean value was obtained using the total station.

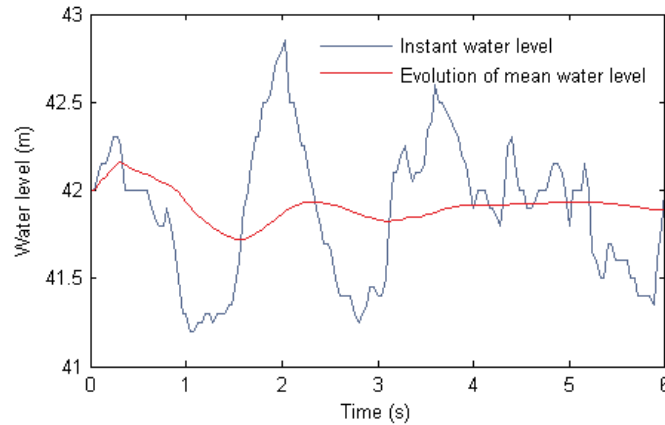

**Figure 8.** Example of the recording of the water level and evolution of mean value for one pools of the studied fishways.

## Data fitting and validation

The statistical analysis during the whole document can be divided into three main analysis types: 1) regression or data fitting, 2) model comparison and 3) performance analysis. In all cases the analyses were undertaken in R (R Core Team, 2016).

The least squares method was adopted to perform all the regression and fitted coefficients for each type and subtype of fishway were evaluated using root mean square errors (RMSE), and determination coefficient ( $R^2$ ) as well as graphically.

Following this, when the proposed fits and methodologies were compared to other available methods Bayesian Information Criterion (BIC) was used (Priestley, 1981; Kass and Wasserman, 1995).

Finally, to analyze the performance and the applicability of the proposed methods, fitted equations were used to predict water level distributions (predicted data) observed in field. In these cases, mean relative error (MRE) with respect to the measured real data (observed data), was used as descriptor of the achieved accuracy.

It is worth mentioning that for the water level calculation *Escalas 2012* software was used (version 1.0 included in Fuentes-Pérez et al. (2012)), nevertheless, the water level can be calculated manually using the defined algorithm in chapter 1 (Figure 10) or by implementing it in the desired program. A new version of this software including the result of the present thesis will be soon available under the reference Fuentes-Pérez et al. (2018) (in prep).







# Chapter 1

Modeling Water-Depth Distribution in Vertical-Slot Fishways under  
Uniform and Nonuniform Scenarios

*Journal of Hydraulic Engineering 140 (2014)*

[http://dx.doi.org/10.1061/\(ASCE\)HY.1943-7900.0000923](http://dx.doi.org/10.1061/(ASCE)HY.1943-7900.0000923)



# Modelling water depth distribution in vertical slot fishways under uniform and non-uniform scenarios

J.F. Fuentes-Pérez<sup>1</sup>; F.J. Sanz-Ronda<sup>2</sup>; A. Martínez de Azagra Paredes<sup>3</sup>; and A. García-Vega<sup>4</sup>

## Abstract

Vertical slot fishways are a type of fish pass of wide operating range that allows fish to move across obstacles in rivers. This study aims to model the performance of these structures, under uniform and non-uniform water levels profiles, using discharge coefficients involving the downstream water level together with a logical algorithm. This will allow to explain the hydraulic behavior of this type of fishways under tailwater levels and flow variations on rivers. Two vertical slot fishways located in Duero River (North-Central Spain) subject to different hydraulic conditions were studied for the validation of the proposed formulation. The observed values are consistent with the predicted results and, among others, demonstrate the importance of including variables which consider downstream water level. Consequently, the proposed discharge coefficients together with the algorithm have resulted in a method which enables to improve the performance of both existing and future vertical slot fishways. This will have major implications in real-life scenarios where uniform water level profiles are rarely achieved.

**CE Database subject headings:** Fishways; Water level; Hydraulic design; Simulation models; Hydraulic structures.

---

<sup>1</sup>GEA Ecohydraulics, Department of Hydraulics and Hydrology, ETSIIAA, University of Valladolid (UVa). Avenida de Madrid 44, Campus La Yutera, 34004 Palencia (Spain). [jfuentes@iaf.uva.es](mailto:jfuentes@iaf.uva.es)

<sup>2</sup>GEA Ecohydraulics, Department of Hydraulics and Hydrology, ETSIIAA, University of Valladolid (UVa). Avenida de Madrid 44, Campus La Yutera, 34004 Palencia (Spain). [jsanz@iaf.uva.es](mailto:jsanz@iaf.uva.es)

<sup>3</sup>GEA Ecohydraulics, Department of Hydraulics and Hydrology, ETSIIAA, University of Valladolid (UVa). Avenida de Madrid 44, Campus La Yutera, 34004 Palencia (Spain). [amap@iaf.uva.es](mailto:amap@iaf.uva.es)

<sup>4</sup>GEA Ecohydraulics, Department of Hydraulics and Hydrology, ETSIIAA, University of Valladolid (UVa). Avenida de Madrid 44, Campus La Yutera, 34004 Palencia (Spain). [ana.garcia.vega@iaf.uva.es](mailto:ana.garcia.vega@iaf.uva.es)

# Introduction

Loss of longitudinal connectivity by man-made obstructions is one of the main ecological problems in regulated rivers (Nilsson et al., 2005; Branco et al., 2012). This issue particularly affects migratory fish, which require different environments for the principal stages of their life cycle (Porcher and Travade, 2002). However, the social benefits of these obstacles make it impractical to remove them and often, the only way to restore longitudinal connectivity, at least partly, is by building fish passes (Wang et al., 2010; Calluaud et al., 2012).

One of the most widely used fish passes are vertical slot fishways (VSFs). These structures are widespread mainly due to their capacity to cope with different flows (Tarrade et al., 2011) and their versatility regarding the water depth available for upstream fish movement (Liu et al., 2006). VSF consists on an open channel divided into a number of pools by cross-walls equipped with vertical slots. This configuration divides the total height of the obstacle into small head drops ( $\Delta H$ ) and forms a jet at slots, the energy of which is dissipated by mixing in pools (Liu et al., 2006).

Based on their geometric configuration, there are many types of VSFs (Rajaratnam et al., 1986, 1992; Wu et al., 1999; Puertas et al., 2004). However, the most common configuration is that of the Hell's Gate model, with double or single slots (model 1 according to Rajaratnam et al. (1986)) (Figure 9).

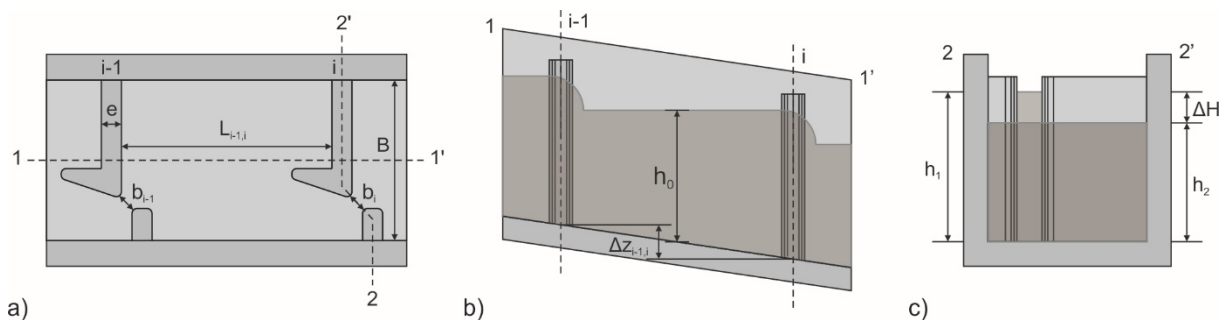

**Figure 9.** Schematic representation of Hell's Gate model with a single slot (model 1 defined by Rajaratnam et al. 1996), the model under study. a) Plant. b) Longitudinal section. c) Cross section. Note: The symbols are defined in the notation section.

In some cases, the flow of VSFs is described by the equation for weirs proposed by Poleni, (1717) (FAO/DVWK, 2002; Krüger et al., 2010), discounting in the discharge coefficient ( $C_d$ ) the effect of the lower contraction (Eq. 3). In other cases, their flow can also be compared to that

of a submerged orifice with an area equal to the product of the width ( $b$ ) and the water level upstream the slot ( $h_1$ ) (Eq. 4) (Martínez de Azagra 1999; Larinier 2002; Bermúdez et al. 2010; Wang et al. 2010) and discounting in the discharge coefficient ( $C_2$ ) the effect of contractions.

$$Q = \frac{2}{3} \cdot C_1 \cdot b \cdot h_1^{1.5} \cdot \sqrt{2 \cdot g} \quad 3$$

$$Q = C_2 \cdot b \cdot h_1 \cdot \sqrt{2 \cdot g \cdot \Delta H} \quad 4$$

In both equations the discharge coefficients ( $C_1$  and  $C_2$ ) depend on the relative position of the water levels (upstream and downstream ( $h_2$ )) and the geometry of the VSF, while  $g$  stands for the acceleration due to gravity.

In 1986 and 1992 Rajaratnam *et al.*, by using the geometry of the slots, proposed the use of dimensionless relationships to describe discharge in VSFs (Eq. 5 and Eq. 6).

$$Q^* = \frac{Q}{\sqrt{g \cdot S \cdot b^5}} \quad 5$$

$$Q^* = \beta_0 + \beta_1 \cdot (h_0/b) \quad 6$$

where  $\beta_0$  and  $\beta_1$  depend on the geometry of the VSF,  $h_0$  is the mean water depth (measured at the center of the pool),  $S$  is the slope and  $Q^*$  is the dimensionless discharge. These relationships have widely been used (Puertas et al., 2004; Cea et al., 2007) and modified (Wu et al., 1999; Kamula, 2001).

Given the variability in the factors that describe their flow, VSFs behave differently both amongst them and throughout time. Consequently, it is a common practice to simplify their study by using geometrically perfect laboratory models with uniform water level profiles, where  $\Delta H$  is the same in all the slots and equal to topographic difference between slots ( $\Delta z$ ) (Rajaratnam et al., 1986, 1992; Wu et al., 1999; Puertas et al., 2004, 2012; Cea et al., 2007; Bermúdez et al., 2010; Tarrade et al., 2011).

These operational characteristics are difficult to achieve under laboratory conditions and, even more, in real-world conditions. In many cases, due to an inaccurate execution or simply because the ideal working situation is never encountered, fish passes will present non-uniform

water level profiles which may decrease their efficiency for fish passage.

In order to overcome these limitations, the present study aims to improve the modelling of VSFs' hydraulic performance using the equation proposed by Villemonte (1947), to evaluate the influence of downstream water level, together with a logical algorithm. This will allow to estimate the distribution of water depths in both geometrically and not geometrically perfect VSFs (i.e. different  $\Delta z$  between slots, different  $b$  in each slot, etc.), under different uniform or non-uniform profiles.

## Materials and Methods

### Experimental Arrangement and Experiments

Experiments were conducted in two VSFs of Hell's Gate type designed by the Group of Applied Ecohydraulics of the University of Valladolid. Both VSFs are located on two weirs in the Duero River (North-Central Spain). In the first one (VSF1 – 41°37'N, 4°6'W) a succession of 27 slots were studied ( $n = 27$ ), while in the second one (VSF2 – 41°38'N, 3°34'W) a succession of 12 ( $n = 12$ ).

The geometrical parameters of the VSFs were measured by topographic surveying (Figure 9). Both VSFs are composed by pools of a mean length of 2.100 m ( $L \approx 10 \cdot b$ ) and a mean width of 1.600 m ( $B = 8 \cdot b$ ). The average width of slots is 0.200 m and the mean  $\Delta z$  is 0.143 m for VSF1 and 0.189 m for VSF2 with an average slope ( $S = \Delta z / (L + e)$ , where  $e$  is the thickness of the cross-wall) of 0.062 m/m and 0.082 m/m, respectively.

During the experimental procedures the flow rate was controlled by the gates located upstream the structures and was measured by chemical gaging using Rhodamine WT as tracer (Martínez 2001). These gates are used for the maintenance and cleaning in both fishways, however they provide the opportunity to represent in the same season different boundary conditions, that is to say different  $h_1$  in the first slot ( $h_{1,1}$ ) and discharges through the fishways.

This type of experiment was replicated four times to achieve in each VSF different non-uniform water depth distribution profiles (conceptual backwater profile (M1) and drawdown profile (M2) (Rajaratnam et al., 1986; Chow, 2004)) (Table 2). M1 profiles were obtained by reducing the area of the slot situated downstream the last slot studied (increasing  $h_2$  of the last slot studied ( $h_{2,n}$ )) and M2 and uniform (U) profiles were naturally present during the

experiments.

**Table 2.** Results of discharge experiments in VSF-1 and VSF-2.  $h_{2,n}$  is the downstream water depth in the last slot studied (when modelling the performance equal to tailwater level).

Experiment name	Estimated discharge $\pm$ CI (m <sup>3</sup> /s)	Reached Profile	$h_{2,n}$ (m)
VSF1-1	0.247 $\pm$ 0.004	M2	0.700
VSF1-2	0.247 $\pm$ 0.004	M1	0.979
VSF1-3	0.247 $\pm$ 0.004	M1	1.029
VSF1-4	0.165 $\pm$ 0.010	M1	0.617
VSF2-1	0.232 $\pm$ 0.004	U	0.729
VSF2-2	0.232 $\pm$ 0.004	M1	0.858
VSF2-3	0.276 $\pm$ 0.007	U	0.816
VSF2-4	0.276 $\pm$ 0.007	M1	0.990

The water depth was measured in each pool by a graduate scale situated downstream the slots in the center of the cross-walls. In each pool successive measures were made to obtain a stable mean value.

## Discharge Coefficient

Villemonte (1947) described the net flow over a submerged weir as the difference between the free-flow discharge due to  $h_1$  and the free-flow discharge due to  $h_2$ . Taking into account the assumptions of this author and that under free-flow discharge Eq. 4 becomes Eq. 3 ( $\Delta H$  tends to  $h_1$ ), the discharge coefficient for both equations can be defined as,

$$C = \alpha_0 \left( 1 - \left( \frac{h_2}{h_1} \right)^{1.5} \right)^{\alpha_1} \quad 7$$

where  $\alpha_0$  and  $\alpha_1$  are coefficients which depend on the geometry of the slot and the discharge equation used.

Although this coefficient was initially described by Villemonte for weirs, Krüger *et al.* (2010) showed the suitability of similar expressions in the description of the functioning of VSFs.

## Formulation of the algorithm

To simulate the water depth distributions of the VSFs under different boundary conditions, taking into account the specific geometrical characteristics of each slot, it is necessary to

perform an iterative bottom-up calculus considering the discharge through the fishway ( $Q_{fishway}$ ) (or the headwater level ( $h_{1,1}$ )) and  $h_{2,n}$  (Figure 10).

Figure 10 represents the logical algorithm followed in order to solve a particular case where Eq. 8 represents each of the discharge equations proposed. Due to the iterative process, the resolution of the algorithm can be tedious; thus, its programming is highly recommended. Consequently, a computer program called “Escalas 2012” was developed (Fuentes-Pérez et al., 2012).

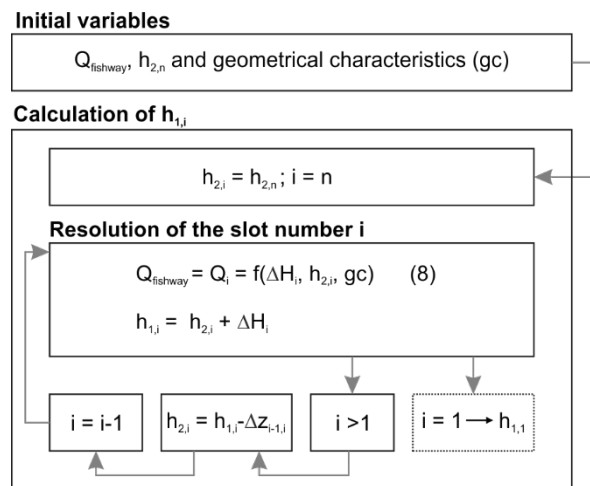

**Figure 10.** Flowchart showing the steps of the proposed algorithm. Note: The symbols are defined in the notation section.

## Validation

The fit of the proposed discharge equations was evaluated using r-squared ( $r^2$ ) with data collected both from the specialized literature and field measurements (Figure 11). The comparison of the predicted water depth profiles using the algorithm and each of the adjusted equations was carried out by comparing the mean relative errors (MRE) for each studied boundary condition combination.

## Experimental Results and Discussion

### Discharge Equations

Figure 11 shows the fitted curves for the proposed equations. All of them represent part of the observed variability due to  $S$  for the different VSF models (Wang et al., 2010); either because they describe the variability of  $\Delta H$  (or  $h_2$ ), which in uniform water level profile settings



is determined by  $S$  (Figure 11(a and b)) or because  $S$  is included in the equation (Figure 11(c) and Eq. 5). This enables the use of the equations in fishways with different slope.

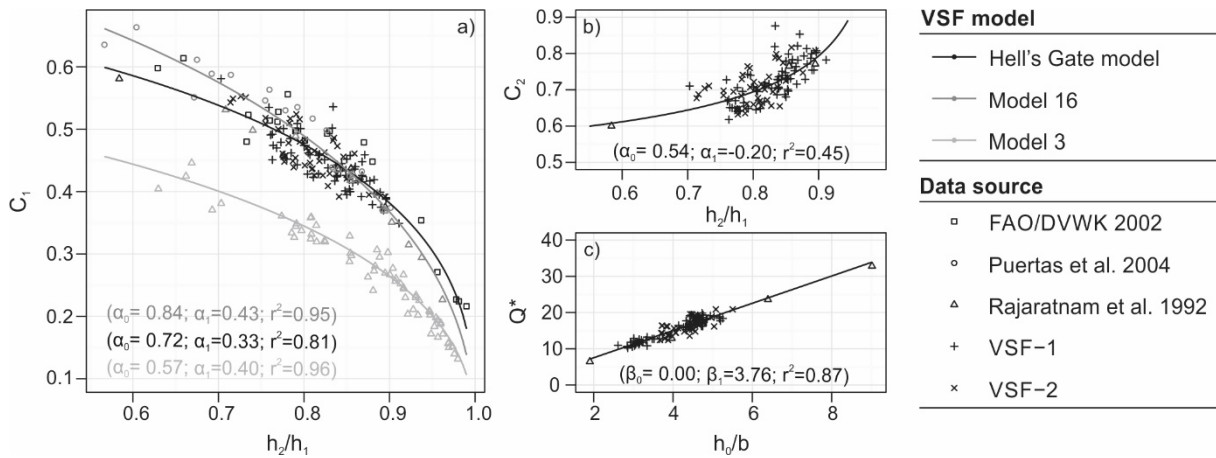

**Figure 11.** Discharge equations adjustment. a) Fit of  $C_1$  for the Hell's Gate, 3 and 16 models defined by Rajaratnam *et al.* (1996). b) Fit of  $C_2$  for Hell's Gate model. c) Fit of Eq. 6 for Hell's Gate model.

As  $h_2/h_1$  approaches zero ( $h_2$  tends to 0),  $h_1$  will reach the critical water depth while  $C_1$  and  $C_2$  will tend to a constant value.  $C_1$  explains well the variability due to  $h_2$ . Regarding  $C_2$ , despite the small  $r^2$ , it provides satisfactory results when the water depth and head drop profiles of the fishway are simulated (Figure 12). This is because Eq. 4 considers, partly, the effect of the water level distribution (by means of  $\Delta H$ ) providing, even when using a constant value for  $C_2$ , more satisfactory results, under non-uniform water levels profiles, than the other discharge equations.

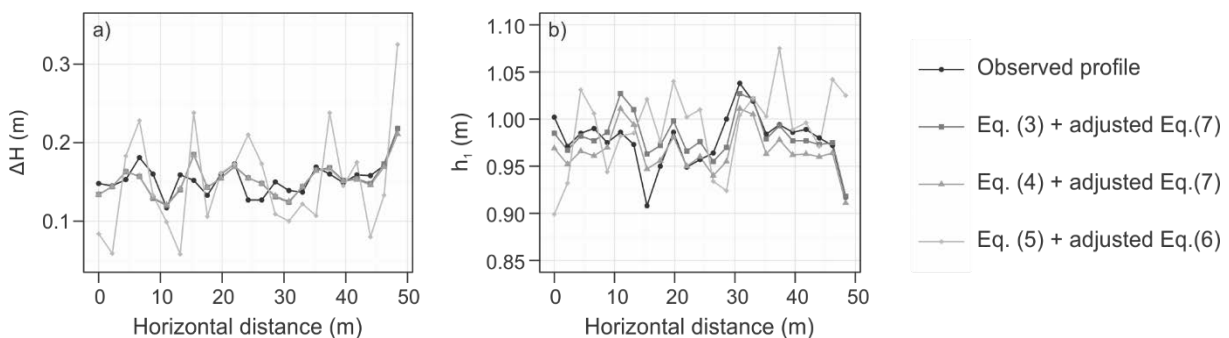

**Figure 12.** Observed and predicted  $\Delta H$  and  $h_1$  profiles using the algorithm for VSF1-1 according to the different equations. Horizontal distance represents the separation between slots and in 0 is situated the upper slot.

In contrast to Eq. 3 and Eq. 4, Eq. 5 does not directly consider water depth in the slot. The variability of water depth is explained by Eq. 6 by means of  $h_0$ , and thus provides a higher  $r^2$  than the other adjustments (Figure 11(c)). Furthermore, Eq. 6 dismisses all the variability

provided by  $h_2$ , making it only possible to explain strictly uniform water level profiles (Rajaratnam et al., 1986). In order to interpret non-uniform cases, it is interesting to adapt data from the literature to include variables such as  $h_2$  as shown in Figure 11(a) (model 3 and 16).

## Water depth and head drop profiles

Figure 12 underlines the importance of considering parameters that take into account the hydrodynamic conditions of the slot, that is, either  $h_1$  and  $h_2$  or  $h_1$  and  $\Delta H$ . Weir and orifice equations (Eq. 3 and Eq. 4) together with Villemonte's discharge coefficient (Eq. 7) are able to describe well the observed  $\Delta H$  profiles (Figure 12(a)) and are capable of capturing changes in  $h_{2,n}$  (MRE for all experiments of 8.88% and 8.93%, respectively). However the dimensionless equations (Eq. 5 and Eq. 6) do not simulate properly the observed values as shown by the high MRE for  $\Delta H$  (40.25%).

Regarding  $h_1$  (Figure 12(b)), weir and orifice equations predict a similar profile to the one observed (MRE of 1.87% and 2.17%, respectively). With the dimensionless equations, the MRE is higher (5.84 %) and it increases as the influence of  $h_{2,n}$  rises. Moreover, when using dimensionless equations the described profile is considerably different to the observed one.

## Conclusions

The proposed discharge coefficients enable, using a logical algorithm, the modelling of the uniform and non-uniform water-level profiles of both geometrically and not geometrically perfect VSFs. Furthermore, this methodology has been evaluated successfully by the experimental study of two existing structures as well as analyzing cases from the literature.

According to the results presented here, Eq. 3 and Eq. 4 together with the discharge coefficients defined by Villemonte (1947) (specific to each type of VSF) provide the best option to design and evaluate VSFs.

To get accurate water depth predictions it is essential to use equations which include a variable that considers downstream water level ( $h_2$  or  $\Delta H$ ). This provides a means to incorporate both the variation in water levels as well as, given the relationship between  $S$  and  $\Delta H$  in uniform profiles, the different slopes used in the design.

The use of these discharge coefficients allows the simulation of the distributions of both water

levels and head drops in VSFs. This will enable to evaluate the behavior of different solutions prior or after their construction and detect and correct deficiencies in fishway designs.

Finally, in order to evaluate the performance and wider applicability of the proposed formulations it would be interesting to apply it to other fishways with different hydraulic connections between pools.

## Acknowledgments

The authors would like to thank all the members of the Group of Applied Ecohydraulics (GEA Ecohidráulica) at the University of Valladolid, as well as Dr. Sara Fuentes Pérez, who has participated actively in the revision of this technical note.

## Notation

The following symbols are used in this technical note:

$B$	=	width of pools (m)
$b$	=	slot width (m)
$b_i$	=	slot $i$ width (m)
$C$	=	generic discharge coefficient
$C_1$	=	discharge coefficient for Eq. 3
$C_2$	=	discharge coefficient for Eq. 4
$e$	=	thickness of the cross-wall (m)
$g$	=	acceleration due to gravity ( $m/s^2$ )
$h_0$	=	mean water depth of flow in pool in relation to the center of the pool (m)
$h_1$	=	mean water depth of flow in pool in relation to the upstream of the slot (m)
$h_{1,i}$	=	mean water depth of flow in pool in relation to the upstream of the slot $i$ (m)
$h_2$	=	mean water depth of flow in pool in relation to the downstream of the slot (m)
$h_{2,i}$	=	mean water depth of flow in pool in relation to the downstream of the slot $i$ (m)
$i$	=	slot number
$CI$	=	95% confidence interval
$L$	=	pool length (m)
$L_{i-1,i}$	=	pool length between slot $i$ and slot $i-1$ (m)

$n$	=	total number of slots
$Q$	=	discharge or flow rate ( $\text{m}^3/\text{s}$ )
$Q^*$	=	dimensionless discharge
$Q_{fishway}$	=	discharge through fishway ( $\text{m}^3/\text{s}$ )
$Q_i$	=	discharge through slot $i$ ( $\text{m}^3/\text{s}$ )
$r^2$	=	determination coefficient
$S$	=	slope of the fishway (m/m)
$\alpha_0$	=	dimensionless coefficient for Eq. 7
$\alpha_1$	=	dimensionless exponent for Eq. 7
$\beta_0, \beta_1$	=	dimensionless coefficients for Eq. 6
$\Delta H$	=	difference in water level between pools or head drop ( $h_1 - h_2$ ) (m)
$\Delta H_i$	=	difference in water level between pools or head drop in the slot $i$ ( $h_{1,i} - h_{2,i}$ ) (m)
$\Delta z$	=	topographic difference between slots (m)
$\Delta z_{i-1,i}$	=	topographic difference between slots $i-1$ and $i$ (m)



# Chapter 2

Non-uniform hydraulic behaviour of pool-weir fishways: A tool to  
optimize its design and performance

*Ecological Engineering 86 (2016)*

<http://dx.doi.org/10.1016/j.ecoleng.2015.10.021>



# Non-uniform hydraulic behavior of pool-weir fishways: A tool to optimize its design and performance

J.F. Fuentes-Pérez<sup>1</sup>; F.J. Sanz-Ronda<sup>2</sup>; A. Martínez de Azagra Paredes<sup>3</sup>; and A. García-Vega<sup>4</sup>

## Abstract

Fishways are structures that aim to achieve the free movement of fish through transversal obstacles in rivers. Despite the wide research about their performance, their hydraulic study and characterization has been so far limited to uniform hydraulic conditions which are usually difficult to reach in natural scenarios, either because inaccurate building or simply because the studied situations during the design of the prototypes are never encountered. This study aims to model pool-type fishways with submerged notches and orifices under different regimes, and uniform and non-uniform performances. For this purpose, the classical formulation used in their design has been modified by studying a real-scale fishway under 29 different boundary conditions. The proposed new formulation together with a logical bottom-up iterative calculation is able to predict the observed water level distributions. This study demonstrates that orifices and notches can be considered independently when estimating the water level distribution and discharge through the fishway, and the need to modify the classical formulation. The modelling under non-uniform water level profiles will allow to enhance and adapt fishways to achieve a greater fish passage during longer time periods.

**Keywords:** Pool-weir fishways; Water levels; Flow discharges; Hydraulic design; Non-uniform performance

---

<sup>1</sup>GEA Ecohydraulics, Department of Hydraulics and Hydrology, ETSIIAA, University of Valladolid (UVa). Avenida de Madrid 44, Campus La Yutera, 34004 Palencia (Spain). [jfuentes@iaf.uva.es](mailto:jfuentes@iaf.uva.es)

<sup>2</sup>GEA Ecohydraulics, Department of Hydraulics and Hydrology, ETSIIAA, University of Valladolid (UVa). Avenida de Madrid 44, Campus La Yutera, 34004 Palencia (Spain). [jsanz@iaf.uva.es](mailto:jsanz@iaf.uva.es)

<sup>3</sup>GEA Ecohydraulics, Department of Hydraulics and Hydrology, ETSIIAA, University of Valladolid (UVa). Avenida de Madrid 44, Campus La Yutera, 34004 Palencia (Spain). [amap@iaf.uva.es](mailto:amap@iaf.uva.es)

<sup>4</sup>GEA Ecohydraulics, Department of Hydraulics and Hydrology, ETSIIAA, University of Valladolid (UVa). Avenida de Madrid 44, Campus La Yutera, 34004 Palencia (Spain). [ana.garcia.vega@iaf.uva.es](mailto:ana.garcia.vega@iaf.uva.es)

# Introduction

Current society needs a large volume of fresh water to keep its present lifestyle, whether for irrigation, to generate electricity or to fulfil industrial, domestic and recreational needs. This, coupled with the exponential population growth, has caused the installation of a great number of infrastructures to collect and use this resource (Nilsson et al., 2005).

These structures are usually cross-sectional to the river, breaking its longitudinal connectivity and blocking the movement of some animals such as fish, which require different environments for some of the most important stages of their life cycle (Porcher and Travade, 2002; Branco et al., 2013). In the best case scenario, the impact of these barriers will cause the diminution in abundance of some species and, in the worst case scenario, their disappearance (Larinier, 2001; Lucas et al., 2001; Branco et al., 2012). It is in this context that fish passes or fishways arise to facilitate the free movement of fish fauna through these obstacles (Clay, 1995; FAO/DVWK, 2002; Larinier, 2002a) .

Fish passes are a clear example of ecological engineering, since they are civil engineering devices, which can be natural-like according to their type, with an efficiency, understood as the proportion of fish from a given population that attempt and succeed in surpassing the obstacle, associated to their hydrodynamic variables (discharge, velocity, depth, power, turbulence fields, etc.) and a combination of swimming capacity, behavior, and motivation of fish (Bermúdez et al., 2010; Sanz-Ronda et al., 2015b). In addition, these hydrodynamic variables depend on environmental parameters, such as fluctuation in water levels upstream and downstream of the structure (Fuentes-Pérez et al., 2014).

In Europe, the installation of fishways has increased since the implementation of the Water Framework Directive (European Commission, 2000). However, the efficiency of these structures has been questioned due to the wide diversity of fish species and the great unknowns regarding their swimming abilities, migration periods, and motivation (Bunt et al., 2012; Williams et al., 2012). Therefore, biological and ecological studies are essential, particularly in less studied species, such as potamodromous species (Roscoe and Hinch, 2010; Ana T Silva et al., 2012; Bunt et al., 2012; Katopodis and Williams, 2012). In recent years, in the Iberian Peninsula, this knowledge gap has been addressed by a number of studies (Alexandre et al., 2013; Branco et al., 2013; Santos et al., 2012; Sanz-Ronda et al., 2015a; Silva



et al., 2012; among others). From a practical viewpoint, all of these studies should show a correct hydraulic characterization in order to enable the application of the collected knowledge to new designs.

The most common fishways are pool-type fishways (Clay, 1995; Martínez de Azagra, 1999; FAO/DVWK, 2002; Puertas et al., 2012). They consist of a sloping-floor channel divided by weirs, cross-walls, or baffles into a series of pools, distributing the height to be crossed by the fish ( $H$ ) into several smaller water drops ( $\Delta H$ ) (Larinier, 2002a). A further classification of pool-type fishways is possible according to the type of connection between pools, being one of the most popular those composed by submerged notch and orifices (SNOF) (Larinier, 2008) (Figure 13).

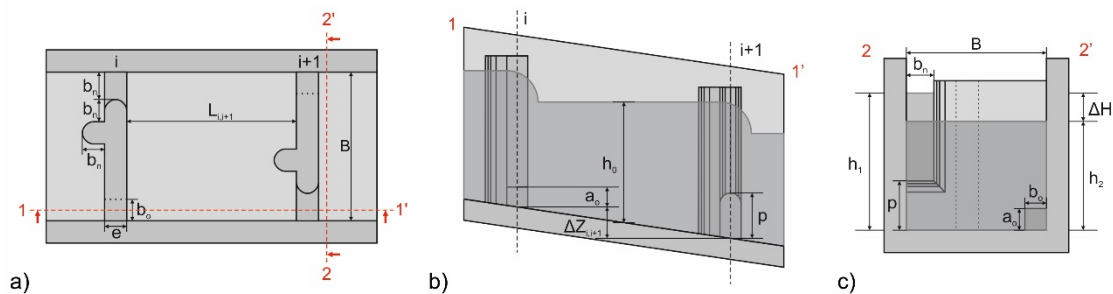

**Figure 13.** Schematic representation of a submerged notch and orifice fishway (SNOF) pool, used in the present study: (a) plan, (b) longitudinal section, (c) cross section. Symbols are defined in the notation section.

This type of fishways can have two different performances or regimes, streaming or plunging, depending on whether the downstream water level ( $h_2$ ) influences or not, respectively, upstream water level ( $h_1$ ) (Rajaratnam et al., 1988; Larinier, 2002a). Likewise, it is also possible to define different sub-regimes within these two main performances (Ead et al., 2004).

Pool and weir type fishways have been commonly designed with notches working under plunging conditions (Kim, 2001; Yagci, 2010; Santos et al., 2012). However, in SNOF, the notch is designed to operate in a streaming regime, which has been shown to enhance the upstream movements of species like Iberian barbel (*Luciobarbus bocagei*), Iberian chub (*Squalius pyrenaicus*) or Iberian nase (*Pseudochondrostoma duriense*), and seems to be more suitable for rivers with fish with wide morpho-ecological traits (Silva et al., 2009; Branco et al., 2013; Sanz-Ronda et al., 2015a; Fuentes-Pérez et al., 2017a). Furthermore, SNOF shows additional benefits such as alternating submerged orifices from side to side. This orifice configuration

has shown higher rates of passages than other configurations for the Iberian barbel (Ana T Silva et al., 2012).

Previous reports have widely studied similar type of designs using either classical weir-discharge equations (Martínez de Azagra, 1999; Kim, 2001; FAO/DVWK, 2002; Larinier, 2002a; Boiten and Dommerholt, 2006; Santos et al., 2012) or dimensionless relationships (Rajaratnam et al., 1989; Ead et al., 2004; Yagci, 2010); however, these studies were always performed under uniform water level operational conditions (same mean water level ( $h_0$ ) and  $\Delta H$  in all pools). This simplification limits the interpretation of their behavior once they are installed because fishways will work under changing non-uniform water level profiles which may decrease their efficiency (Fuentes-Pérez et al., 2014), due to large variations in the hydrological regime of rivers, as it is the case in the Mediterranean regions (Gasith and Resh, 1999), or due to an inaccurate execution. That is to say, the boundary conditions and its geometry will determine not only the regime of the fishway (plunging, streaming or mixed) but also the water level distributions (non-uniform or uniform profiles), which may modify the observed efficiency in laboratory models.

In order to solve the above mentioned issues, this study aims to define the operational conditions of submerged notch and orifice fishways both under different regimes and uniform and non-uniform performances, modifying the classical formulation that has widely been used to describe their behavior. This will allow to describe and predict their functioning, i.e. the hydraulic variables, under natural scenarios, and evaluate the influence of modifications in the design of the fishways regarding the necessities of the target species, making possible the improvement of fishways efficiency. The above is summarized in the main following contributions: (i) new definition of calculus equations for SNOF under uniform and non-uniform water level profiles; (ii) evaluation and validation of predictability of water levels of the proposed equations; (iii) theoretical demonstration of the use of the defined equations and algorithm to improve the fishway efficiency.

## **Materials and methods**

### **Fishway description**

The experiments were conducted in a real-scale SNOF with a design discharge of 0.278 m<sup>3</sup>/s (Figure 14). This structure is located in the Tormes River near the village of La Flecha

(Salamanca, Spain) and it is characterized by small deviances from design parameters ( $\pm 0.010$  m) (Sanz-Ronda et al., 2010). The average topographic difference between cross-walls ( $\Delta\bar{Z}$ ) is 0.247 m, that is to say, it has an average slope ( $\bar{S} = \Delta\bar{Z} / (\bar{L} + \bar{e})$ , where  $\bar{L}$  stands for the length of the pool and  $\bar{e}$  for the thickness of the cross-wall) of 0.088 m/m (Figure 14). Cross-walls consist on an alternative succession of submerged hydrodynamic notches (mean width ( $\bar{b}_n$ ) of 0.310 m and mean height of the sill ( $\bar{p}$ ) of 0.917 m) and bottom orifices (mean width ( $\bar{b}_o$ ) of 0.197 m and mean height ( $\bar{a}_o$ ) of 0.191 m).

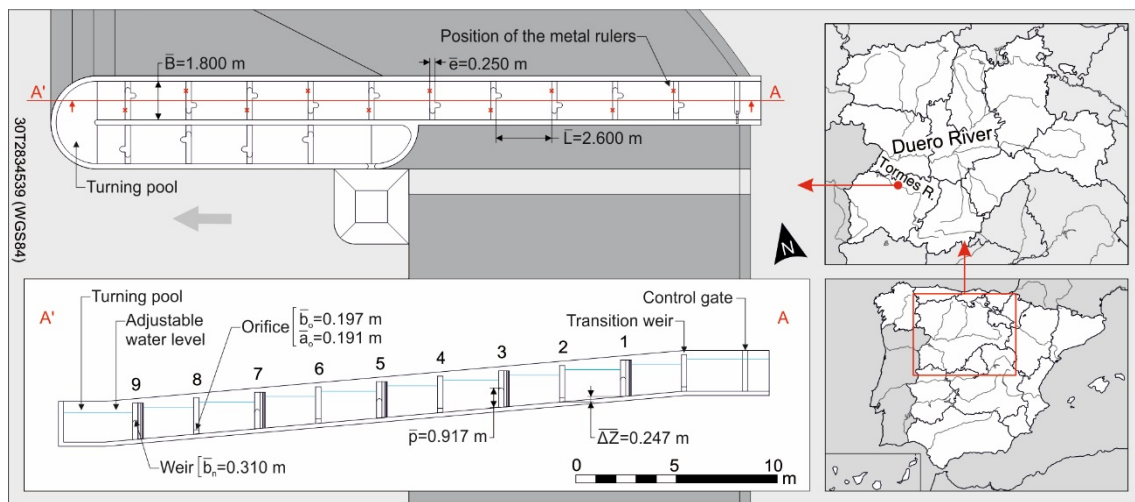

**Figure 14.** Location and schematic representation of the studied SNOF in La Flecha (Salamanca, Spain). Numbers 1 to 9 indicate the nine cross-walls used in this study.

The geometrical parameters were measured by topographic surveying with a total station Leica TC307 to a resolution of 0.001 m. Smaller details, such as orifice and notch dimensions, were measured by means of a metal ruler to a millimetric precision level. The measurement of all individual characteristics was necessary in order to discriminate between the non-uniform water levels produced by geometrical differences and the non-uniformity due to changes on boundary conditions.

## Experimental arrangement and experiments

Table 3 summarizes all the experiments performed. To determine flow interdependencies between orifices (O) and notches (N), both were studied separately and in combination (NO). In the experimental cases where notches or orifices had to be closed, wood covers were used and the junctions with the concrete were completely sealed by means of insulation foam. In those experimental cases involving the notch, streaming (S) and plunging (P) regimes were

studied. For each combination above (O, N.S., N.P., NO.S. and NO.P.) three different discharge regimes were studied: low (L), high (H), and medium (M) (Table 3). The discharge was controlled through the gate situated in the upper slot (Figure 14) and was measured by chemical gaging using Rhodamine WT as tracer (Martínez, 2001). This gate was installed for the maintenance and cleaning of the fishway, and provided the opportunity to achieve different hydrodynamic scenarios in a single season.

**Table 3.** Description of the studied boundary conditions. O: Orifice alone; N: Notch alone; NO: Notch and orifice together; L: Low discharge; M: Medium discharge; H: High discharge; P: Plunging performance; S: Streaming performance; P/S: Partly plunging and partly streaming; 1: Backwater profile; 2: Drawdown profile; U: Uniform profile

Name	Discharge (m <sup>3</sup> /s)	$h_{1,1}$ (m)	$h_{2,9}$ (m)
O.L.2	0.078	1.483	0.860
O.L.U	0.072	1.120	0.861
O.L.1	0.060	1.110	1.447
O.M.2	0.080	1.514	0.987
O.M.U	0.065	1.339	1.090
O.M.1	0.063	1.282	1.481
O.H.U	0.073	1.531	1.298
O.H.1	0.070	1.502	1.485
N.P.L.U	0.077	1.173	0.881
N.P/S.L.1	0.077	1.172	1.503
N.S.M.2	0.135	1.297	0.862
N.S.M.U	0.135	1.292	1.055
N.S.M.1	0.135	1.294	1.467
N.S.H.2	0.242	1.510	1.083
N.S.H.U	0.242	1.507	1.256
N.S.H.1	0.242	1.509	1.440
NO.P.L.U	0.078	0.992	0.795
NO.P/S.L.1	0.078	0.994	1.472
NO.P.M.U	0.095	1.065	0.827
NO.P/S.M.1	0.095	1.066	1.466
NO.P.H.U	0.131	1.141	0.912
NO.P/S.H.1	0.131	1.141	1.475
NO.S.L.U	0.151	1.195	1.040
NO.S.L.1	0.151	1.190	1.488
NO.S.M.U	0.195	1.306	1.097
NO.S.M.1	0.195	1.299	1.391
NO.S.H.U	0.271	1.455	1.230
NO.S.H.1	0.271	1.458	1.479
NO.S.H.U*	0.337	1.519	1.255

\*Extra case taking advantage of the high river flow recorded while the experiments were carried out.

The study was conducted in nine cross-walls located upstream, after the control gate and a transition weir (Figure 14). The turning pool was adapted to allow the artificial modification of the water level to achieve uniform profiles (U) (same depth in all pools), as well as non-uniform profiles which include conceptual backwater profiles (1) (higher depths upstream) and drawdown profiles (2) (higher depths downstream) (Rajaratnam et al., 1986; Chow, 2004; Fuentes-Pérez et al., 2014).

After excluding nearly impossible cases, due to the complexity required to reach them in real fishways (e.g. backwater profiles in NO experiments), twenty-nine boundary condition combinations were studied (Table 3). The water level was measured to a millimetric precision in each cross-wall by means of metal rulers installed downstream and in the opposite site of the notches, where the water surface is more stable (Figure 14). The water level oscillations were recorded for 8 seconds using a camera (Canon EOS 600D) with a sampling rate of 25 Hz; in all the cases a stable mean value was obtained after two seconds (50 samples).

## Discharge equations

There are different ways to interpret the operation of SNOFs. Rajaratnam et al. (1988, 1989), following earlier works on vertical slot fishways (Rajaratnam et al., 1986) and baffle fishways (Rajaratnam and Katopodis, 1984), proposed the use of dimensionless relationships to describe their performance. These equations have been widely proven and reaffirmed (Ead et al., 2004; Yagci, 2010). However, according to the formula employed, they are independent of the  $h_2$  of each cross-wall and, therefore, they are only valid for uniform water level profiles. It is also possible to use the classical equations for weirs to interpret the operation of SNOFs (Martínez de Azagra, 1999; FAO/DVWK, 2002; Larinier, 2002a; Santos et al., 2012). In this case, discharge through a notch ( $Q_n$ ) is described using the equation for weirs proposed by Poleni (1717) together with a discharge coefficient that describes the working conditions under plunging performance ( $C_p$ ), and another coefficient that reflects the effect (contractions and upstream discharge influence) of the streaming performance ( $C_s$ ) (Eq. 9). In addition, the discharge through submerged orifices ( $Q_o$ ) is described by the equation derived from Bernoulli's principle together with a discharge coefficient that takes into account the effect of contractions and expansions ( $C_o$ ) (Eq. 10). In both equations  $g$  stands for gravity.

$$Q_n = \frac{2}{3} \cdot C_p \cdot C_s \cdot b_n \cdot (h_1 - p)^{1.5} \cdot \sqrt{2 \cdot g} \quad 9$$

$$Q_o = C_o \cdot b_o \cdot a_o \cdot \sqrt{2 \cdot g \cdot \Delta H} \quad 10$$

$C_p$  is usually defined by Rehbock's equation for free discharge sharp-crested rectangular weirs without contractions (application range:  $0.05 \leq (h_1 - p) \leq 0.80$  and  $0.01 \leq p \leq 1.00$ ) (Eq. 11) (Rehbock, 1929; Kim, 2001; Ead et al., 2004) or by a constant coefficient (ranging from 0.495 to 0.750, where usually a value of 0.600 is selected for design purpose) (Rajaratnam et al., 1988; Martínez de Azagra, 1999; FAO/DVWK, 2002; Larinier, 2002a).  $C_s$  takes into account the performance of the notches in submerged conditions, thus, generally the equation for sharp-crested rectangular weir proposed by Villemonte (1947) is used (Eq. 12,  $\beta_0 = 1.000$  and  $\beta_1 = 0.385$ ) (application range:  $0 \leq (h_2 - p)/(h_1 - p) \leq 0.90$ ) (Martínez de Azagra, 1999; FAO/DVWK, 2002; Larinier, 2002a).  $C_s$  will be equal to 1 when the notch works under plunging performance.

$$C_p = 0.605 + \frac{1}{1000 \cdot (h_1 - p)} + 0.08 \cdot \left( \frac{h_1 - p}{p} \right) \quad 11$$

$$C_s = \beta_0 \cdot \left[ 1 - \left( \frac{h_2 - p}{h_1 - p} \right)^{1.5} \right]^{\beta_1} \quad 12$$

## Water level calculation

To simulate the water level distributions in SNOFs during different boundary conditions, it is necessary to take into account the specific geometrical characteristics of each pool and cross-wall. After defining these characteristics, an iterative bottom-up calculation can be carried out considering boundary conditions: the discharge through the fishway or the headwater level (upstream water level in the first cross-wall considered,  $h_{1,1}$ ), and  $h_{2,n}$  (where  $n$  is the number of cross-walls studied or in the fishway). A complete definition of this algorithm is explained in Fuentes-Pérez et al. (2014).

## Validation

The fit of the proposed discharge equations has been evaluated using r-squared ( $R^2$ ), as well as variance of observed and predicted values ( $\sigma^2 = \text{RSS}/(n-2)$ , where RSS is the residual sum of squares) and graphical validation. The comparison of the predicted water level profiles has

been carried out by comparing the mean relative errors (MRE) for each case as well as by checking water level distributions.

## Experimental results and discussion

### Discharge coefficients

Traditionally, the same discharge coefficients have been used for the design of both fishways and weirs. However, the performance of fishways is different mainly due to the slope, thickness of cross-walls, contractions and the dependency between cross-walls, which will probably cause a different water level distribution. Thus, the classical formulation must be either confirmed or modified.

### Orifices

The study of submerged orifice fishways has demonstrated, for wide a range of operation conditions, that  $\Delta H$  in all cross-walls remains constant independently of the water levels upstream and downstream the fishway (Boiten and Dommerholt, 2006). This property is derived from Eq. 10 and from the fact that the discharge coefficients only depend on the shape of the submerged orifice and the thickness of the cross-walls, remaining constant for different water levels.

The above described performance has also been observed in the fishway studied here. For all orifice experiments ( $\Delta H$  from 0.176 m to 0.324 m), the discharge coefficient ( $C_o \pm SD = 0.876 \pm 0.050$ ) was independent from the water levels of each cross-wall ( $h_1$ ,  $h_2$ , and  $\Delta H$ ). The values obtained agree with the values observed by other authors (Larinier, 2002a; Boiten and Dommerholt, 2006). Likewise,  $C_o$  shows a small correlation with the dimension of the orifice ( $a_o \cdot b_o$ ) and  $Q_o$ . This is due to the fact that, since  $C_o$  is independent to the water level variables, the simplifications from orifice dimension measuring and fishway discharges (chemical gaging) are transmitted directly to  $C_o$ . The cross-walls were built *in situ* with concrete, which produced geometrical irregularities that cannot be characterized with the geometrical variables used in the calculation ( $a_o$  and  $b_o$ ). These irregularities are greater in orifices than in notches, due to their position near the rough bed and their small dimensions. Since these deviations are not considered in  $a_o$  and  $b_o$  measures, they are translated to variance in  $C_o$ .

The observed properties in submerged orifices make them of particular interest to design fishways with autonomous water drop compensation. However, they can suffer from

inappropriate attractions or locating difficulty, obstructions, and the drawbacks of trapping floating debris (FAO/DVWK, 2002; Larinier, 2002a). Likewise, some fish species may be reluctant to use them (e.g. American shad (*Alosa sapidissima*) (Larinier, 2002a)) or may prefer other types of connections between pools (e.g. Iberian chub (Branco et al., 2013) or Iberian nase (Sanz-Ronda et al., 2015a)).

## Notches

Although orifices are important to maintain the fishways clean of sediments and to allow the pass of certain fish species (Larinier, 2002a), generally the most important fraction of discharge will flow through the notch. To differentiate between plunging and streaming effects, and to determine the independency between notches and orifices, first, taking into account the calculated  $C_o$ ,  $Q_o$  was deducted from combined notch and orifice experiments. Then, the coefficients for the submerged equation ( $\beta_0$  and  $\beta_1$  in Eq. 12) were determined from observed data, as recommended by Villemonte (1947) (Figure 15(b)). In order to do this, only the data from submerged notches were used, obtaining a first approximation for the coefficients, where  $\beta_0$  can be considered a constant approximation of  $C_p$ . To evaluate the distribution of  $C_p$ , the first approximation for  $C_s$  was deducted from all data (dividing the data by the estimated  $C_s$ ). This demonstrated that the distribution of  $C_p$  depends on  $h_1$ , and describes an exponential model with a decelerated increase of the coefficient that approaches a horizontal asymptote (Figure 15(a)). Finally, the observed models for discharge coefficients were fitted together, using all the data, to obtain the final expressions (Figure 15, Eq. 13 and Eq. 14).

$$C_p = 0.689 \cdot \left[ 1 - e^{-8.889 \cdot (h_1 - p)} \right] \quad 13$$

$$C_s = \left[ 1 - \left( \frac{h_2 - p}{h_1 - p} \right)^{1.5} \right]^{0.331} \quad 14$$



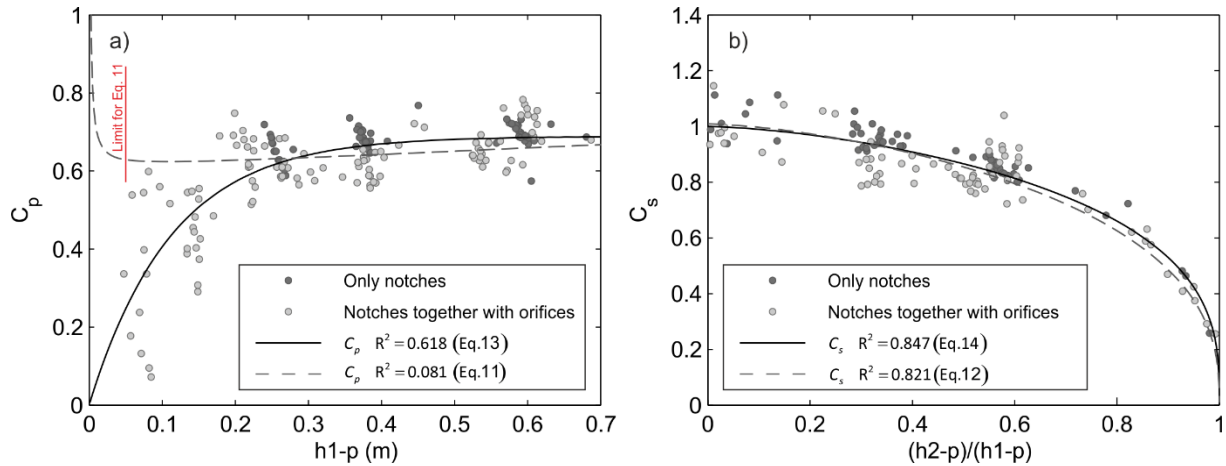

**Figure 15.** Fits of the discharge coefficients for the notches. a) Discharge coefficient for the plunging regime ( $C_p$ ). b) Discharge coefficient for the streaming regime ( $C_s$ ).

Figure 15 shows that notch data for both set of experiments (notches together with orifices and notches alone) can be explained by the same equations, demonstrating that the performance of orifices and notches can be considered independent for the estimation of water level distribution. Likewise, even if independent fits for each set are considered, the same mean variance is obtained (0.003).

The  $C_p$  model differs from the values and equations proposed by other authors (Rehbock, 1929; Rajaratnam et al., 1989; Martínez de Azagra, 1999; FAO/DVWK, 2002; Larinier, 2002a; Ead et al., 2004); however, its performance has a logical explanation. The coefficient must be 0 when  $h_1-p \leq 0$ , then, when the discharge starts, the influence of the sill is big producing a small  $C_p$ . As  $h_1$  increases, sill influence remains almost constant, producing a decelerated progressive increase of  $C_p$ . Likewise, the kinetic influence of the cross-wall situated upstream, for first stages of the discharge (low  $h_1$ ), is negligible. It is worth mentioning that the measuring error in the experiments increases at lower discharges (lower  $C_p$  values) due to a greater influence of the geometrical measure precision, as well as the nature of the chemical gaging and the lower mixing power in pools. As the water height increases,  $C_p$  will approach a horizontal asymptote with a value in the range suggested by other specialized references (Martínez de Azagra, 1999; FAO/DVWK, 2002; Larinier, 2002a).

Regarding  $C_s$ , most of the guides for fishway design recommend Eq. 12, which uses the coefficients proposed by Villemonte (1947) for rectangular weirs ( $\beta_0 = 1.000$  and  $\beta_1 = 0.385$ ) (Martínez de Azagra, 1999; FAO/DVWK, 2002; Larinier, 2002a). However, despite the fit being considerably good (Fig 3(b),  $R^2=0.821$ ), as recommended by Villemonte, these coefficients

should be calculated or evaluated for each configuration. The proposed new relations suggest that for the same combination of boundary conditions, there is a smaller influence of  $C_s$  (a greater value) than in Villemonte's experiments due to the different conditions in the fishway (possibly due to a different slope or smaller water path than the one used by the author).

The observed difference between the data and the proposed model, as argued in the previous section, seems to be related mainly to the simplification of geometrical variables and chemical gaging. This becomes more obvious when comparing experimental data from notches, with data from notches together with orifices (Figure 15). The variance of NO experiments is greater (0.005 vs 0.001) because the geometrical simplification of the orifices is also involved in the estimation of  $C_p$  and  $C_s$ . However, as described in the next section, the deviations in the estimation of water level distribution as a result of this variance will be rather small.

## Depth profiles and applications

With equations able to predict non-uniform water level distribution, it will be possible to model the performance of fishways under dynamic situations and adapt their operation to new conditions, improving, when necessary, the attraction efficiency (number of fish that are able to find the entrance (Bunt et al., 2012)) and passage efficiency (number of fish exited of those that entered in the fishway (Bunt et al., 2012)) and, thus, achieving a higher fishway efficiency during longer periods of time.

The proposed equations (Eq. 13 and Eq. 14) together with the algorithm described in Fuentes-Pérez et al. (2014) are able to estimate water level distributions with a high degree of precision in all the studied cases (Table 4 and Figure 16). In all cases, the maximum MRE was registered in orifices when working alone (Table 4). This, as it was discussed previously, is explained by the observed variance in the discharge coefficient. Despite this, the deviations are small, higher in  $\Delta H$  distributions because of the normalization of the error (Figure 16(b))

**Table 4.** MRE (%) for the studied profiles with the proposed equations.

Profile	Notch and orifices			Notch			Orifices			Mean		
	$h_1$	$h_2$	$\Delta H$	$h_1$	$h_2$	$\Delta H$	$h_1$	$h_2$	$\Delta H$	$h_1$	$h_2$	$\Delta H$
Uniform	1.74	1.93	3.79	0.84	0.84	3.70	4.40	4.97	9.36	1.96	2.17	4.69
Backwater	1.36	1.52	7.17	0.66	0.65	4.89	4.12	3.85	9.30	1.88	1.88	7.13
Drawdown	-	-	-	0.68	0.66	4.23	8.25	9.13	10.03	4.46	4.89	7.13
Mean	1.57	1.74	5.35	0.73	0.72	4.28	5.38	5.68	9.53	2.28	2.43	6.09

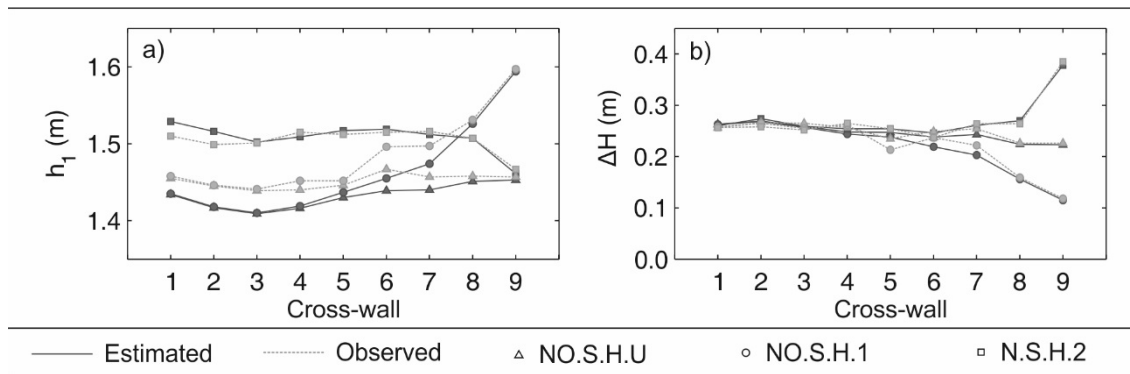

**Figure 16.** Water level distributions in the 9 studied cross-walls of the fishway. a) Observed and estimated  $h_1$  profiles for 3 of the 29 cases. b) Observed and estimated  $\Delta H$  profiles for 3 of the 29 cases.

When the fishway is placed correctly (i.e. in the attractive areas for fish (Larinier, 2002b)), first, the fish will need to find the fishway entrance in order to pass it. To accomplish this, the entrance needs to strike a compromise between attracting the fish and enabling them to enter (Larinier, 2002b; Bunt et al., 2012; Williams et al., 2012). Non-uniform water level distribution, produced by changes in headwater or tailwater levels, will modify the hydraulic conditions in the entrance from the ones defined during the design process, causing backwater or drawdown profiles. Backwater profiles are produced by decreasing tailwater or increasing headwater levels. These can generate excessive  $\Delta H$  in most downstream cross-walls, increasing velocities (the expected maximum velocity is  $\sqrt{2 \cdot \Delta H \cdot g}$  (Rajaratnam et al., 1986; Liu et al., 2006)), turbulence, noise or oxygenation. Although in a first instant this can increase the attraction (Williams et al., 2012), entrance can be limited according to the swimming speed of the migrating species involved or the produced turbulence, and sometimes it will require the fish to jump to enter, reducing or impeding its use for some species (Bunt et al., 2012). For instance, Branco et al. (2013) and Sanz-Ronda et al. (2015a) observed a reduced use of notches for Iberian chub, Iberian barbel and Iberian nase, when the fishway entrance was working in plunging regimes. Regarding velocity limits at the entrance, Larinier (2002b) defines an optimal water speed for salmonids and large migrants in the order of 2.0 m/s to 2.4 m/s ( $\Delta H = 0.2-0.3$  m). Similar values can be considered for species with comparable swimming capacities such as Iberian barbel and Iberian nase (Sanz-Ronda et al., 2015b).

The backwater profile created by the increase in headwater level can be managed, for instance by designing a first cross-wall (the most upstream one) with a gate and, after this, some cross-walls without  $\Delta Z$  between them. Likewise, backwater profile created by the decreases of the

tailwater level can be managed by decreasing the sill of the downstream notches or installing submerged pre-barrages that will absorb the reduction of the water level. However, the latter is not a probable case as the fishway should be designed to work under the reasonably highest difference between the headwater and tailwater levels of the obstacles (Wang, 2008).

Regarding drawdown profiles, they occur when the tailwater level increases or headwater level decreases. However, in most cases, the headwater level will remain more or less constant (Larinier, 2002a). These profiles decrease the  $\Delta H$  in most downstream cross-walls, reducing, among others, the velocity at the entrance, which, in turn, can produce a diminution on the attraction efficiency. Larinier (2002b) recommends a minimum velocity of 1 m/s at the entrance. In both cases, these issues can be solved by increasing the sill elevation of the most downstream notch or increasing the discharge input in the most downstream pool.

It is possible to use the proposed equations and calculation process to model all defined performances, and design specific solutions (as mentioned above). However, as the fishway should be designed to work under the reasonably highest difference between water levels, and as the headwater level in most cases will not change significantly, the most probable case will be the drawdown profile where tailwater level increases. Figure 17(a) shows the simulation of the defined two options to improve the attraction of a drawdown profile for the studied fishway, that is, the elevation of the sill of the most downstream cross-wall ( $p + 0.550$  m) and the increase of the discharge input in the last pool ( $Q + 0.250$  m<sup>3</sup>/s). Both solutions will increase the final  $\Delta H$  to reach to the desired value.

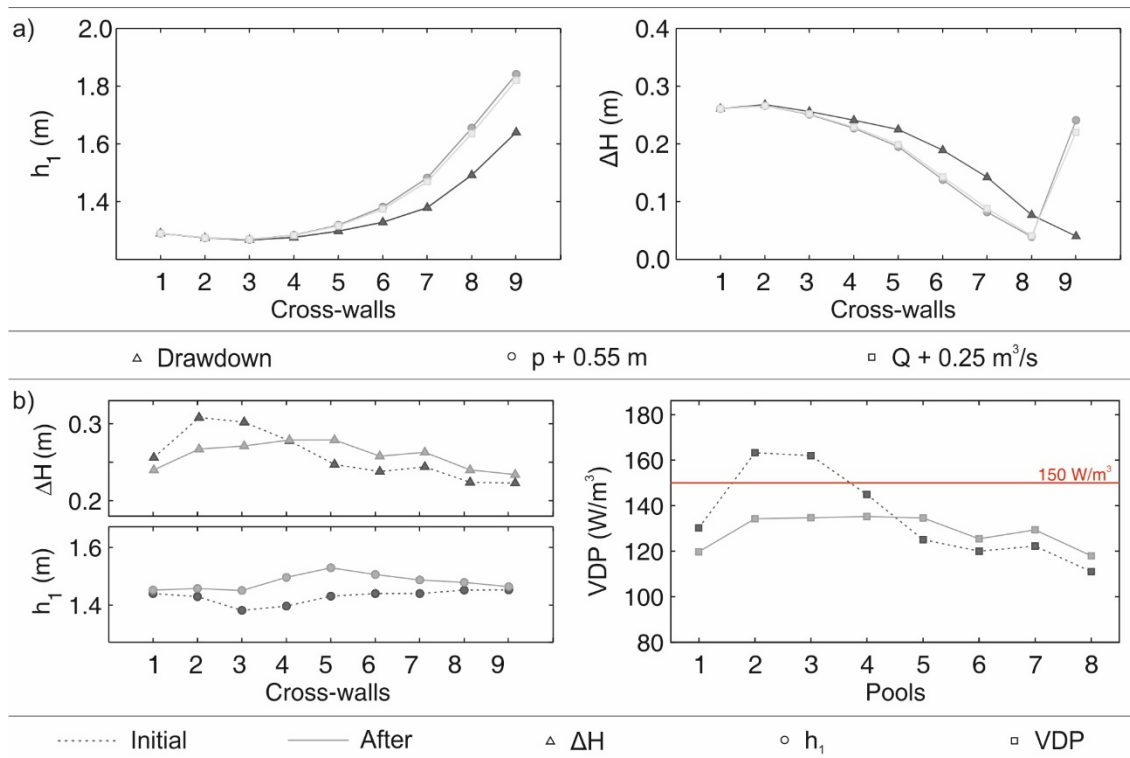

**Figure 17.** Examples of use of the proposed equations to improve efficiency of the fishways. a) Distribution of  $h_1$  and  $\Delta H$  in an attraction optimization example with 2 options to improve the use of a fishway with drawdown profile (boundary conditions:  $Q = 0.200$  m<sup>3</sup>/s and  $h_{2,9} = 1.600$  m). b) modification of  $h_1$ ,  $\Delta H$  and  $VPD$ , in a fishway with higher  $\Delta Z$  ( $\approx 0.30$  m) between cross-walls 3 and 4, and 4 and 5 after the increase of sill height in downstream cross-walls (from  $p_3$  to  $p_9$  +0.05, +0.10, +0.12, +0.08, +0.06, +0.04, +0.02 m, respectively) (boundary conditions:  $Q = 0.271$  m<sup>3</sup>/s and  $h_{2,9} = 1.230$  m).

Once fish have entered to the fishway, its internal hydraulic performance will determine the passage efficiency. Usually, at practical and design level, two main factors should be considered when evaluating the internal performance:  $\Delta H$  between adjacent pools and the volumetric power dissipation ( $VPD$ ). It is possible to estimate both variables with the proposed equations, as  $VPD$  only depends on the pool geometry, and the calculated variables ( $VPD = Q \cdot \Delta H \cdot g \cdot \rho / (h_0 \cdot B \cdot L)$  where  $\rho$  is the water density (kg/m<sup>3</sup>)) (FAO/DVWK, 2002; Larinier, 2002a; Towler et al., 2015).  $VPD$  will provide an indication of average pool turbulence and  $\Delta H$  can be considered as an indicative of the maximum velocity that the fish will need to overcome.

$VPD$  should be maintained under certain levels according to the target species, fishway type and type of pools (step pool, resting pool or turning pool) (Towler et al., 2015). It is roughly

correlated with more complex parameters (such as velocity field, turbulence or shear stress levels within the pool), which, in turn, are strongly correlated with fish preferences. For instance, several studies have observed that, within a pool, the Iberian barbel has preference for areas with lower velocities, turbulence and shear stress (Silva et al., 2011; Ana T Silva et al., 2012; Alexandre et al., 2013).

The maximum velocity to be overcome by the fish, directly related with  $\Delta H$ , will occur in the cross-walls. This fact has been shown for example in electromyogram telemetry studies that revealed that Iberian barbels reached the maximum swimming speed during the orifice passage within a pool-weir fishway (Alexandre et al., 2013). After surpassing the cross-wall is believed that the fish rest, if necessary, within the recirculation areas of the pools before facing to the next cross-wall (Silva et al., 2011; Alexandre et al., 2013).

Thus, each cross-wall can be seen as a small obstacle that fish will need to surpass taking advantage of its abilities and the resting area. In this sense, local design or constructing failures inside the fishway could reduce fish passage. By modelling the internal performance of a fishway, it is possible to compensate for any possible drawbacks. For instance, Figure 17(b) simulates a deviation in  $\Delta Z$  (real  $\Delta Z + 0.05$  m) between cross-walls 3 and 4, and 4 and 5, and shows one of the possible solutions. The deviation of  $\Delta Z$  will produce the increment of  $VPD$  and  $\Delta H$  from the recommended ones for the target species in the upstream pools, which could be a limiting factor for passage. However, by using the proposed equations and bottom-up calculations, it is possible to design a solution (in this case the increase of downstream notches sill height) to compensate for these errors, reducing both,  $\Delta H$  and  $VPD$ .

## Summary and conclusions

In this article, a modification of the discharge equations for submerged notch and orifice fishways is proposed. Its formulation differs from the classical method because (a) the equations have been specifically adapted to fishways and (b) cases with non-uniform water level profiles have also been studied. The equations fit the observed data and, for most common design conditions, suggest higher discharge coefficients than the traditional values and equations used. Likewise, a new logical distribution pattern for  $C_p$  has been detected, observed, and modelled.

The discharge equations together with a logical bottom-up iterative calculation are able to correctly model the uniform and non-uniform water levels of fishways. This will allow to create specific solutions for changing boundary conditions or when building errors are detected.

This work also exposes the necessity to specifically adapt the classical design equations to fishways in order to model correctly the hydraulic parameters ( $\Delta H$ ,  $h_0$ ,  $VPD$ , etc.) that might limit their use. The correct modelling and interpretation could be used to design more accurate and better adapted solutions, to determine whether a fishway has hydraulic constraints which could compromise its efficiency, and to adapt or correct fishways when necessary.

## Acknowledgements

The authors would like to thank Dr. Sara Fuentes-Pérez for her editorial advice and active participation in the revision of this paper, and all the employers and owners of the hydropower plant of La Flecha (SAVASA S.L.) for their help during the experiments.

## Notation

The following symbols are used in this paper:

$a_o$	=	height of the orifice (m)
$B$	=	pool width (m)
$b_n$	=	notch width (m)
$b_o$	=	orifice width (m)
$C_o$	=	discharge coefficient for orifices
$C_p$	=	discharge coefficient for the plunging regime
$C_s$	=	discharge coefficient for the streaming regime
$e$	=	thickness of the cross-wall (m)
$g$	=	acceleration due to gravity ( $m/s^2$ )
$h_0$	=	mean water level of the flow in the pool in relation to the centre of the pool (m)
$h_1$	=	mean water level of the flow in the pool in relation to the upstream of the notch (m)
$h_{1,i}$	=	mean water level of the flow in the pool in relation to the upstream of the notch in the cross-wall number $i$ (m)

$h_2$	=	mean water level of the flow in the pool in relation to the downstream of the notch (m)
$h_{2,i}$	=	mean water level of the flow in the pool in relation to the downstream of the notch in the cross-wall number $i$ (m)
$i$	=	cross-wall number
$L$	=	pool length (m)
$n$	=	total number of cross-walls
$p$	=	sill height (m)
$Q$	=	discharge or flow rate ( $Q = Q_n + Q_o$ for combined cases) ( $\text{m}^3/\text{s}$ )
$Q_n$	=	discharge through notches ( $\text{m}^3/\text{s}$ )
$Q_o$	=	discharge through orifices ( $\text{m}^3/\text{s}$ )
$R^2$	=	determination coefficient
$S$	=	slope of the fishway (m/m)
$VPD$	=	volumetric power dissipation ( $\text{W}/\text{m}^3$ )
$\beta_0, \beta_1$	=	dimensionless coefficients for Eq. 12
$\Delta H$	=	difference in water level between pools or head drop ( $\Delta H = h_1 - h_2$ ) (m)
$\Delta Z$	=	topographic difference between cross-walls (m)
$\rho$	=	density of water ( $\text{kg}/\text{m}^3$ )
$\sigma^2$	=	variance





# Chapter 3

Villemonte's approach: A general method for modelling uniform and non-uniform performance in stepped fishways

*Knowledge and management of aquatic ecosystems 418 (2017)*

<http://dx.doi.org/10.1051/kmae/2017013>



# Villemonte's approach: A general method for modelling uniform and non-uniform performance in stepped fishways

J.F. Fuentes-Pérez<sup>1</sup>; A. García-Vega<sup>2</sup>; F.J. Sanz-Ronda<sup>3</sup>; and A. Martínez de Azagra Paredes<sup>4</sup>;

## Abstract

Stepped fishways are the most popular solutions to enable the free movement of fish fauna through weirs and dams. Given the flow variation of rivers throughout the year, successful fish migration through stepped fishways relies on the accurate discharge calculation and their modelling under variable boundary conditions. This study aims to propose a general method for flow and water level calculation of stepped fishways, unifying different findings in specialized literature. To achieve this purpose, the relation defined by Villemonte is used and tested under laboratory and field case studies. This study shows that the hydraulic behavior of a wide range of stepped fishway typologies can be explained based on a single equation, as well as the need of calibration of the coefficients involved in this equation for different subtypes. Furthermore, the proposed method enables the water level modelling under variable boundary conditions, which in turns allows the analysis of stepped fishways hydraulic performance under different river scenarios. The comparison of the hydraulic parameters in the fishways with the physical capacities and preferences of fish will contribute to the fulfilment of their main objective: allow free movement of fish fauna.

**Keywords:** Discharge coefficient; Flow measurement; Vertical slot fishway; Pool and weir fishway; Nature-like fishway

---

<sup>1</sup>Centre for Biorobotics, Tallinn University of Technology. Akadeemia tee 15A – 111, 12618, Tallinn, Estonia. [juan.fuentes@ttu.ee](mailto:juan.fuentes@ttu.ee)

<sup>2</sup>GEA Ecohydraulics, Department of Hydraulics and Hydrology, ETSIIAA, University of Valladolid (UVa). Avenida de Madrid 44, Campus La Yutera, 34004 Palencia (Spain). [ana.garcia.vega@iaf.uva.es](mailto:ana.garcia.vega@iaf.uva.es)

<sup>3</sup>GEA Ecohydraulics, Department of Hydraulics and Hydrology, ETSIIAA, University of Valladolid (UVa). Avenida de Madrid 44, Campus La Yutera, 34004 Palencia (Spain). [jsanz@iaf.uva.es](mailto:jsanz@iaf.uva.es)

<sup>4</sup>GEA Ecohydraulics, Department of Hydraulics and Hydrology, ETSIIAA, University of Valladolid (UVa). Avenida de Madrid 44, Campus La Yutera, 34004 Palencia (Spain). [amap@iaf.uva.es](mailto:amap@iaf.uva.es)

# Introduction

Humans have found in rivers a source to satisfy many of their basic necessities, which have resulted in their geomorphological and ecological alteration (Nilsson et al., 2005). One of the most notable alteration in rivers is the installation of cross-sectional structures (e.g. weirs and dams) to satisfy water and energy requirements or for flood control. These structures fragment the stream and can block the movement of some animals such as fish, which require different environments to complete their life cycles (Lucas et al., 2001; Branco et al., 2013). In recent years, ensuring undisturbed fish migration has become a key component of watershed restoration (Santos et al., 2014) and the installation of fishways is one of the most widely adopted solution in order to achieve this objective.

There are many types of fishways. The most common ones consist of a succession of cross-walls in a sloped channel, namely, stepped fishways or fish ladders (Figure 18) (e.g. vertical slot fishway (VSF) (Rajaratnam et al., 1986; Larinier, 2002a; Fuentes-Pérez et al., 2014), pool and weir fishway (PWF) (Rajaratnam et al., 1988; Larinier, 2002a; Fuentes-Pérez et al., 2016), and step-pool nature-like fishway (SPNF) (FAO/DVWK, 2002; Wang and Hartlieb, 2011)). These structures divide the total height of the obstacle ( $H$ ) in smaller drops ( $\Delta H$ ) in each cross-wall to ensure that the hydraulic conditions inside are in the range of the physical capacities of fish fauna and, thus, enable their passage.

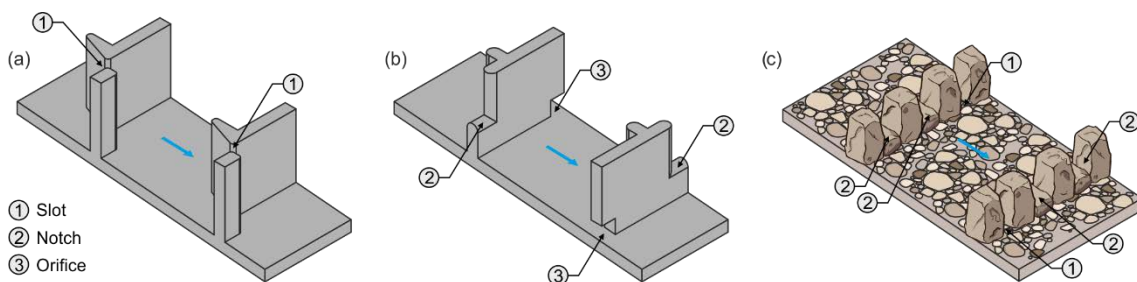

**Figure 18.** Examples of sections of stepped fishways. Each type (a) Vertical slot fishway, (b) Pool and weir fishway and (c) Step-pool nature-like fishway can have different subtypes according to their morphology and connections.

Depending on the type of fishway, they can have different kind (slots, notches, or orifices) and number of connections in the cross-walls between pools, from a single slot, like for example in some VSFs, to multiple combinations in SPNFs.

The discharge and performance of fishways can be modelled in many different ways, which enables the classification of these hydraulic calculations into two big groups: dimensionless relationships (Rajaratnam et al., 1986, 1989; Ead et al., 2004; Yagci, 2010) and classical weir equations (Larinier, 1992; Clay, 1995; Martínez de Azagra, 1999; Boiten and Dommerholt, 2006; Krüger et al., 2010). The first group of equations is only useful when  $\Delta H$  is equal to the topographic difference between pools ( $\Delta Z$ ) (*i.e.* same water depth in all pools) (Rajaratnam et al., 1986). This is known as uniform water level profile, which is difficult to achieve in field conditions due to the temporal variability of river flow (Fuentes-Pérez et al., 2016; Marriner et al., 2016). Regarding classical weir equations, the most commonly used equations are the orifice equations derived from Torricelli's law (Torricelli, 1644) as well as Poleni's weir equation (Poleni, 1717). An accurate selection of the discharge coefficients for these equations is vital in order to achieve precise results, both under uniform ( $\Delta H = \Delta Z$ ) as well as under non-uniform ( $\Delta H \neq \Delta Z$ ) water level conditions. In order to use these equations under both conditions, it will be necessary to consider the water level upstream ( $h_1'$ ) and downstream ( $h_2'$ ) of the cross-wall (Fuentes-Pérez et al., 2014).

Non-uniform profiles in fishways are usually classified in two main different water level profiles (Rajaratnam et al., 1986): M1 or backwater profile, which produces higher mean depth ( $h_0$ ) and smaller drops ( $\Delta H < \Delta Z$ ) in the downstream pools of the fishway, and M2 or drawdown profile, which contrary, generates lower  $h_0$  and higher drops ( $\Delta H > \Delta Z$ ) in downstream pools. It is likely to occur in field conditions due to the variable hydrological regime of river or small deviances in the construction of the fishway (Fuentes-Pérez et al., 2016; Marriner et al., 2016). This will modify the hydrodynamics of the flow inside the fishway, which may lead to an incompatibility with fish fauna preferences or capabilities, affecting the efficiency of fish passage (Fuentes-Pérez et al., 2016; Sanz-Ronda et al., 2016). For instance, M1 profiles may improve the passability due to the lower velocities in the cross-walls or the reduction on the volumetric power dissipation (*VPD*) within the pools, but it may decrease the attractivity due to reduction of velocity in the most downstream cross-walls. Contrary, M2 profiles may led to more attractive scenarios but may generate too demanding drops to be surpassed or conditions with too high *VPD* in downstream pools.

Thus, non-uniformity must be considered in fishway research. However, the simplification of the study of fishways is a widespread problem and, in many cases, their performance is

modelled according to uniform conditions (Rajaratnam et al., 1986; Wu et al., 1999; Puertas et al., 2004; Bermúdez et al., 2010; Wang et al., 2010; Tarrade et al., 2011; among others).

Using some of the most extended fishway guidelines (Larinier, 1992; FAO/DVWK, 2002; Krüger et al., 2010) it is possible to explain, at least partly, non-uniform profiles. Likewise, some recent works have shown that it is possible to use classical weir equations together with the submerged weir discharge coefficient ( $C_s$ ) proposed by Villemonte (1947) to model fishways uniform and non-uniform water level profiles in specific subtypes of VSF (Fuentes-Pérez et al., 2014) and PWF (Fuentes-Pérez et al., 2016).

In the present paper, we study the use of Villemonte's equation as a general discharge coefficient definition for flow and water level calculation of all stepped fishway types under field conditions. This is achieved by calibrating the discharge coefficient for the different fishway types (PWF, VSF and SPNF) and subtypes (different morphologies within the types) studied in the field and in specialized literature, which will enable us to validate this general methodology. The main contributions of this paper are: to (i) prove the usefulness of Villemonte's equation as a general method for the estimation of stepped fishway discharge and uniform and non-uniform water levels profiles; (ii) adjust the coefficients of this equation for flow measurement in stepped fishway types and subtypes proposed by the specialized literature as well as field cases; (iii) show that this equation is able to unify findings in different scientific references.

## Material and Methods

### Theoretical background: recommended discharge equations

The performance and discharge of stepped fishways will be explained by means of classical weir equations. The equation for weirs proposed by Poleni (1717) (Eq. 15) will be used to describe the flow ( $Q$ ) through notches (Larinier, 1992; Martínez de Azagra, 1999; FAO/DVWK, 2002) and slots (FAO/DVWK, 2002; Krüger et al., 2010). On the other hand, the orifice equation derived from Torricelli's law (Torricelli, 1644) (Eq. 16) will be used to describe the  $Q$  through orifices (Larinier, 1992; Martínez de Azagra, 1999; FAO/DVWK, 2002; Boiten and Dommerholt, 2006).

$$Q = \frac{2}{3} \cdot C_s \cdot b \cdot h_1^{1.5} \cdot \sqrt{2 \cdot g} \quad 15$$

$$Q = C_o \cdot b \cdot a \cdot \sqrt{2 \cdot g \cdot \Delta H}$$

16

where  $g$  stands for the gravity,  $h_1$  is the water level upstream the cross-wall deducting the sill height ( $p$ ),  $b$  is the width of notches, slots or orifices,  $a$  is the height of the orifice and  $C$  ( $C_s$  and  $C_o$ ) stands for the discharge coefficients.

Multiple fishways studies have demonstrated that  $C_o$  can be considered independent of the different water level variables involved ( $\Delta H$ ,  $h_2$  and  $h_1$ , where  $h_2$  is the water level downstream the cross-wall deducting  $p$ ) (Brater et al., 1996; Boiten and Dommerholt, 2006; Fuentes-Pérez et al., 2016). This property is derived from Eq. 16 and, for this reason, it can be considered that  $C_o$  will only vary according to the geometrical variables of the orifice (dimensions, shape and cross-wall thickness).

For slots and notches, Villemonte's submerged coefficient will be used as a generic discharge coefficient (Villemonte, 1947). Villemonte derived his coefficient assuming that  $Q$  is the difference between the free-flow discharge due to  $h_1$  ( $Q_1$ ) and the counter-flow discharge due to  $h_2$  ( $Q_2$ ) (Figure 19 and Eq. 17).

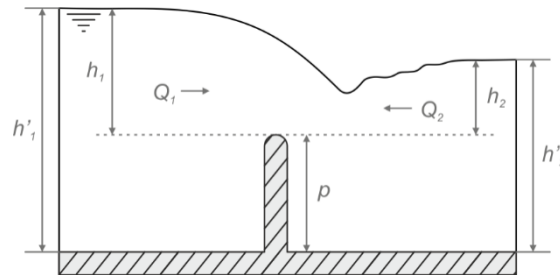

**Figure 19.** Sketch of Villemonte's assumption for submerged flows.  $Q_1$  is the free flow discharge in positive direction controlled by  $h_1$  and  $Q_2$  is the counter-flow discharge due to  $h_2$ .  $p = 0$  in case of slots.

$$Q = Q_1 - Q_2 \rightarrow \frac{Q}{Q_1} = 1 - \frac{Q_2}{Q_1} \quad 17$$

The experiments carried out by Villemonte confirmed this hypothesis,  $Q/Q_1$  ( $C_s$ ) is related functionally to  $1 - Q_2/Q_1$ . Considering this and replacing  $Q_1$  and  $Q_2$  by Eq. 15, the final form of  $C_s$  is obtained (Eq. 18).

$$C_s = \frac{Q}{Q_1} = \beta_0 \left(1 - \frac{Q_2}{Q_1}\right)^{\beta_1} \rightarrow C_s = \beta_0 \left[1 - \left(\frac{h_2}{h_1}\right)^{1.5}\right]^{\beta_1} \quad 18$$

where  $\beta_0$  and  $\beta_1$  are coefficients which depend on the geometry of the slot or notch, pool dimensions, and the discharge equation used. Villemonte concluded that  $\beta_1$  was equal to 0.385 in all his experiments for submerged weirs, however he recommended its calibration for different setups.  $\beta_0$  can be considered as a constant approximation of a free discharge coefficient.

## Hypothesis testing through case studies

Data from peer-reviewed scientific studies, grey literature and from our own field experiments were used to test the hypothesis: Villemonte's equation can be adapted to model different types of stepped fishway under uniform and non-uniform conditions.

A systematic search was carried out following the PRISMA (Preferred Reporting Items for Systematic Reviews and Meta-Analyses) guidelines (Moher et al., 2009) (S1 Appendix). This systematic search was carried out in Google Scholar as well as in Web of Science and Scopus from conception to September 2016 for articles and grey literature on VSFs, PWFs and SPNFs. To standardize and minimize errors only studies containing raw data and appropriate geometrical descriptions were considered for calibrating purpose. This is rather difficult to find and, aside data from our own field tests, only references for VSFs were found useful (Rajaratnam et al., 1986, 1992; FAO/DVWK, 2002; Puertas et al., 2004) (Table 5). Likewise, as only English has been used for the search, this might have introduced a language bias.

**Table 5.** Summary of collected data through references and field experiments.

Type	No. of data	Source
VSF	441	(Rajaratnam et al., 1986, 1992; FAO/DVWK, 2002; Puertas et al., 2004) and 4 field cases <sup>1</sup> , 2 included in (Fuentes-Pérez et al., 2014)
PWF	180	3 field cases <sup>1</sup> , 1 included in (Fuentes-Pérez et al., 2016)
SPNF	45	1 field case <sup>1</sup>

<sup>1</sup>A description of own field cases can be found in S2 Appendix  
<sup>2</sup>All data collected in field cases is included in S3 Data Appendix

Regarding field studies (8 in total), all the fishways are located in the basin of the Duero River, in North-Central Spain (Figure 20). The Department of Hydraulics and Hydrology of the



University of Valladolid was involved in the design of all of them. The information about location, characteristics and geometry of each fishway can be found in S2 Appendix.

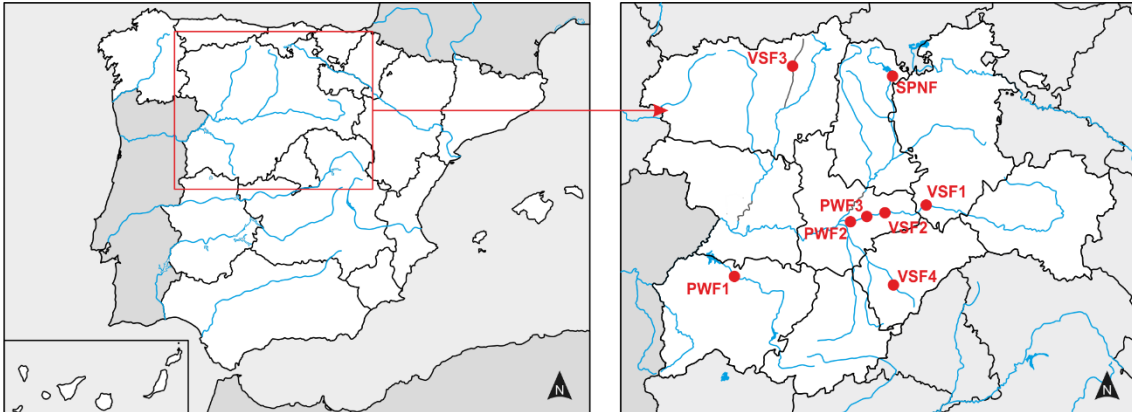

**Figure 20.** Field cases location. Three types of fishways were studied in field: vertical slot fishway (VSF), pool and weir fishway (PWF) and step-pool nature-like fishway (SPNF). Localization coordinates are defined in S2 Appendix.

## Experimental arrangement

The following experimental procedure was used for all field experiments. The geometrical parameters of each structure were measured by topographic surveying with a total station Leica TC307 to a millimetric resolution. Smaller details, such as orifice, notch and slot dimensions were measured by means of metal rulers to millimetric precision level.

The discharge of each studied water level configurations (Table 6) through the structures was obtained by chemical gaging (precision of 0.004 m<sup>3</sup>/s) using Rhodamine WT as tracer (Martínez, 2001). In cases where was possible, boundary conditions were artificially modified in the fishways in order to increase the number of studied boundary conditions. For example, when there was a gate situated upstream, different discharges were measured and, if possible, the water level downstream was also increased and decreased by modifying the section of the last control structures, creating new combinations of boundary conditions (Table 6) (see S2 Appendix for the geometrical information of the field cases and S3 Data Appendix for discharge, water levels and boundary conditions of each studied case).

**Table 6.** Summary of the field studied cases for each fishway type (see S3 Data Appendix for detailed information about each studied case).

Fishway	No. case	$Q$ (m <sup>3</sup> /s)	$h_2'$ final (m)
VSF1	1	0.165	0.617
	2		0.700
	3	0.247	0.979
	4		1.029
VSF2	5	0.232	0.729
	6		0.858
	7	0.276	0.816
	8		0.990
VSF3	9	0.315	1.170
VSF4	10	0.277	0.890
VSF4	11		1.130
PWF1	1	0.077 <sup>1</sup>	0.881
	2		1.503
	3	0.078	1.472
	4	0.095	1.466
	5		0.912
	6	0.131	1.475
	7		0.862
	8	0.135 <sup>1</sup>	1.055
	9		1.467
	10	0.151	1.040
	11		1.488
	12	0.195	1.097
	13		1.391
	14		1.083
	15	0.242 <sup>1</sup>	1.256
	16		1.440
	17		1.230
	18	0.271	1.479
	19	0.337	1.255
PWF2	20	0.394	1.341
PWF3		0.370	0.975
PWF3.2	21	0.187	1.221
SPNF1	1	0.206	0.583
	2	0.329	0.600
	3	0.455	0.593

<sup>1</sup>No flow through orifice (covered)

Water levels were measured to a millimetric precision in each of the pools, by means of metal rulers installed where water surface was found more stable (downstream of the cross-wall and 0.40 m from the sidewall opposite to the notch ( $0.15 \cdot B$ ) or slot ( $0.25 \cdot B$ )). Water level oscillations were recorded for 8 s using a camera (Canon EOS 600D) with a sampling rate of 25 Hz; in all cases after  $\leq 2$  s (50 samples) a stable mean value for the water level was obtained. For SPNF, due to the nature-like morphology and, thus, the absence of clear reference points for the metal rulers, water levels were measured in each of the corners of the pools using the total station. The mean value was used for calculations.

## Data fitting and validation

Data from the literature review and field experiments were combined for each of the different stepped fishway types considered (VSF, PWF or SPNF) and within them for the different possible subtypes (e.g. VSF designs from No. 1 to No. 18 of Rajaratnam *et al.*, 1986). Fishway subtypes are defined as fishways that, within the same type, have substantial differences in the configurations which result in a modification of the flow pattern. A global data table was created for each subtype with the necessary variables to study the proposed relations (*i.e.* type, subtype,  $h_2$ ,  $h_1$ ,  $\Delta Z$ ,  $Q$  and  $b$  and  $a$ , for each of the connections (Figure 18) if applicable). Curve fitting to calculate Villemonte's coefficients ( $\beta_0$  and  $\beta_1$  in Eq. 18) for each study case was undertaken in R, release 3.3.1 (R Core Team, 2016).

Following this, all fitted coefficients for each type and subtype of fishway were evaluated using root mean square errors (RMSE) and determination coefficient ( $R^2$ ) as well as graphically. The proposed method was compared with other available methods of calculation for each fishway type. When different number of fitting parameters were involved between two different fishway calculation methods Bayesian Information Criterion (BIC) was used to compare the performance (Priestley, 1981; Kass and Wasserman, 1995).

In VSFs analysis, as an example, to demonstrate the applicability of the method here proposed, fitted equations were used to predict water level distributions (predicted data). In these cases, mean relative error (MRE) with respect to the measured real data (observed data), was used as descriptor of the achieved accuracy.

# Results and discussion

## Vertical slot fishways

Considering the number of references by fishway, VSFs seem to be one of the most studied and extended fishway types in the world. In 1986 and 1992 Rajaratnam et al. conducted the largest serial study to date of this type of structures. The VSF subtypes defined in these papers (18 in total) have been used as a reference for successive works (Puertas et al., 2004; Fuentes-Pérez et al., 2014) (for a complete description of the geometry of these subtypes please see the original references (Rajaratnam et al., 1986, 1992)). These authors defined dimensionless relationships to explain VSF performance (Eqs. S4.1 and S4.2 in S4 Appendix), including slope ( $S$ ) as a variable and only mean water level in the pool ( $h_0$ ) as a water level descriptor. This has been proven to be useful for uniform water level profiles; however, it is invalid to estimate flow and water level distributions in non-uniform cases (Rajaratnam et al., 1986; Fuentes-Pérez et al., 2014).

Table 7 summarizes the number of observations, the origin of data as well as the fitted coefficients for Eq. 18 for each subtype of VSF defined by Rajaratnam et al. (1992; 1986) after literature and experimental data combination. In all cases, the use of Eq. 18 as discharge coefficient enables to explain precisely the observed variability as shown by the  $R^2$  value. It is worth mentioning that the lower  $R^2$  for subtype 1 may be explained by the higher variances of the four field studies included, compared to the laboratory experiments (Rajaratnam et al., 1986, 1992; Puertas et al., 2004) (Figure 18 (a)).

**Table 7.** Summary of the coefficients for different VSF subtypes using Villemonte’s discharge equation (Eq. 18). L and B are the length and width of the pool respectively.

Subtype	$\beta_0$	$\beta_1$	$R^2$	RMSE	L	B	Data points	Data source
1 <sup>1</sup>	0.705	0.317	0.786	0.0285	10·b	8·b	161	(Rajaratnam et al., 1986, 1992; FAO/DVWK, 2002; Fuentes-Pérez et al., 2014) + 4 field cases
2 <sup>2</sup>	0.671	0.326	0.971	0.0163	10·b	8·b	4	(Rajaratnam et al., 1986, 1992)
3	0.539	0.378	0.946	0.0181	10·b	8·b	45	(Rajaratnam et al., 1986, 1992)
4	1.296	0.387	0.956	0.0372	10·b	8·b	12	(Rajaratnam et al., 1986, 1992)
5	0.568	0.406	0.991	0.0066	10·b	8·b	9	(Rajaratnam et al., 1986, 1992)
6 <sup>1</sup>	0.858	0.574	0.900	0.0472	10·b	8·b	32	(Rajaratnam et al., 1986, 1992; Puertas et al., 2004)
7	0.495	0.337	0.937	0.0138	10·b	8·b	9	(Rajaratnam et al., 1986, 1992)
8	0.322	0.314	0.954	0.0089	5·b	8·b	12	(Rajaratnam et al., 1992)
9	0.312	0.292	0.945	0.0087	5·b	4·b	11	(Rajaratnam et al., 1992)
10	0.317	0.416	0.991	0.0051	5·b	2.67·b	14	(Rajaratnam et al., 1992)
11	0.719	0.458	0.997	0.0057	15·b	8·b	17	(Rajaratnam et al., 1992)
12	0.754	0.465	0.992	0.0220	15·b	4·b	15	(Rajaratnam et al., 1992)
13	1.162	0.531	0.987	0.0126	15·b	2·b	17	(Rajaratnam et al., 1992)
14	0.804	0.469	0.977	0.0159	10·b	8·b	19	(Rajaratnam et al., 1992)
15	0.718	0.468	0.990	0.0091	10·b	8·b	16	(Rajaratnam et al., 1992)
16 <sup>1</sup>	0.844	0.433	0.951	0.0243	10·b	8·b	30	(Rajaratnam et al., 1992; Puertas et al., 2004)
17	0.630	0.301	0.962	0.0089	10·b	8·b	9	(Rajaratnam et al., 1992)
18 <sup>2</sup>	0.740	0.311	0.933	0.0136	10·b	8·b	9	(Rajaratnam et al., 1992)

<sup>1</sup>Recomended by (Rajaratnam et al., 1992); <sup>2</sup>Equal to subtype 1 but with a  $p = 0.15$  m

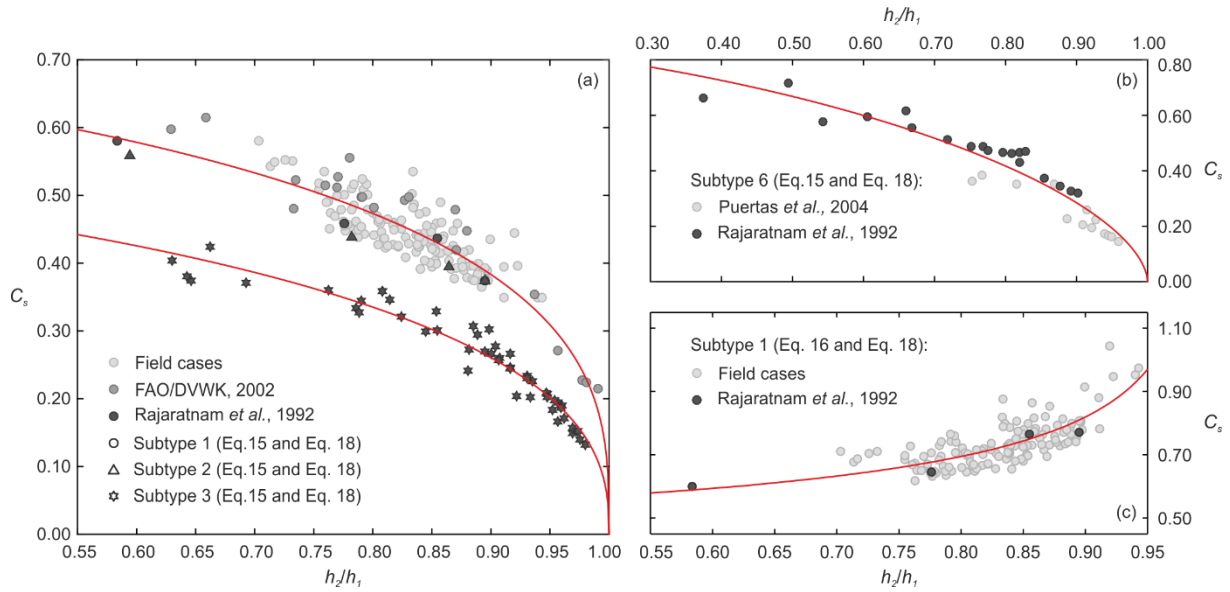

**Figure 21.** Examples of discharge coefficient fits for most relevant (in terms of data points) VSF subtypes. (a) Subtypes 1, 2 and 3 (Fit coefficients and  $R^2$  in Table 7). (b) Subtype 6 (Fit coefficients and  $R^2$  in Table 7). (c) Fit of Eq. 18 for Subtype 1 to be used in Eq. 16 ( $\beta_0 = 0.509$ ,  $\beta_1 = -0.248$ ,  $R^2 = 0.587$ , RMSE = 0.0458).

Figure 21(a) and 19(b) show the fits for some common VSF subtypes using Villemonte's equation. This equation is able to unify findings and observations of different studies. In addition, as shown in Figure 21(a), the same fit could be used in subtypes 2 and 1 despite the presence of a small sill ( $p = 0.15$  m) in the former.

Although in Eq. 18,  $S$  is not considered, the relation between  $h_2$  and  $h_1$  alone is able to account for the observed variance caused by different  $S$  configurations in the same subtype. This can be explained by the fact that  $S$  will determine the relation between both variables ( $h_2$  and  $h_1$ ) under uniform conditions ( $S \cdot (L+e) = \Delta Z = \Delta H = h_1 - h_2$ , where  $L$  is the length of the pool and  $e$  is the thickness of the cross-wall) (Fuentes-Pérez et al., 2014). For this reason, it is possible to use the equation independently of the selected  $S$ , considering only the subtype and the observed water level distributions. It is worth mentioning that in cases where  $S = 0$  (fishways without slope) (Bice et al., 2017), the water level profile will always be non-uniform (Musall et al., 2015) and  $\Delta H$  will only depend on the boundary conditions used. Although Eq. 18 allows its calculation, dimensionless relationships (Eqs. S4.1 and S4.2 in S4 Appendix) (Rajaratnam et al., 1986, 1992) will lead to an indetermination in these cases, as  $S$  is a divider in Eq. S4.1.

Figure 22(a) shows the potential of the proposed equation by correctly estimating the performances observed by Rajaratnam *et al.* in 1986. In contrast to dimensionless

relationships proposed by Rajaratnam *et al.* in 1986, as  $h_2$  and  $h_1$  are involved in the proposed method, considering the geometrical parameters of the fishway, the bottom-up resolution of Eq. 15 and Eq. 18 (i.e. between two consecutive cross-walls,  $i$  and  $i+1$  (c.f. Figs. S2.2 and S2.4 in S2 Appendix):  $h'_{2,i} = h'_{1,i+1} - \Delta Z_{i,i+1}$  and  $h'_{1,i} = h'_{2,i} + \Delta H_i$  (Fuentes-Pérez *et al.*, 2014)) can explain the uniform and non-uniform water level distribution accurately (Table 8).

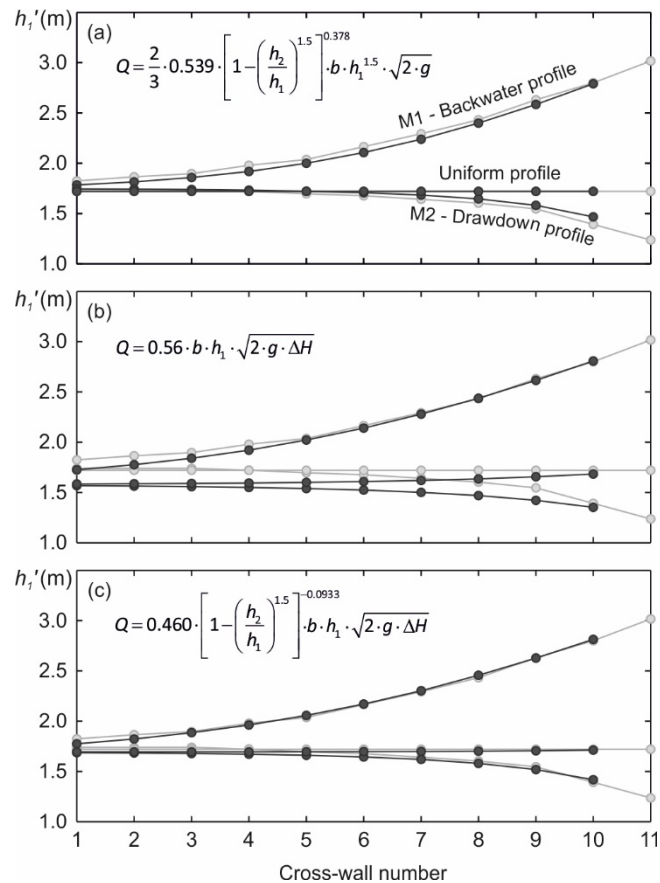

**Figure 22.** Uniform and non-uniform water level profiles in a VSF of subtype 3, observed (grey) by Rajaratnam *et al.* (1986) and simulated (black) by different equation combinations. M1:  $h_2 = 2.712$  m and  $Q = 0.66$  m<sup>3</sup>/s; M2:  $h_2 = 0.931$  m and  $Q = 0.66$  m<sup>3</sup>/s; Uniform:  $h_2 = 1.416$  m and  $Q = 0.66$  m<sup>3</sup>/s. a) Eq. 15 and Eq. 18. b) Eq. 16 and constant coefficient ( $C = 0.56$ ). c) Eq. 16 and Eq. 18.

**Table 8.** Mean relative error for equation combinations and experiments represented in Figure 22.

Profile	Error (%)	Eq. 15 and Eq. 18	Eq. 16 and Eq. 18	Eq. 16 and C = 0.56
Uniform	$\epsilon_{h1}$	0.819	1.278	6.113
	$\epsilon_{\Delta H}$	0.557	0.885	4.492
	$\epsilon_{VPD}$	0.817	1.232	5.852
M1	$\epsilon_{h1}$	2.039	0.967	1.963
	$\epsilon_{\Delta H}$	10.702	10.464	10.295
	$\epsilon_{VPD}$	10.395	9.756	9.609
M2	$\epsilon_{h1}$	1.197	2.324	8.658
	$\epsilon_{\Delta H}$	3.852	3.323	4.722
	$\epsilon_{VPD}$	3.385	3.206	9.359

The correct estimation of water level distribution is vital to assess the performance of fishways, as from this, other variables which are directly related with fish preferences and swimming abilities (Larinier, 2002a, 2002c), such as volumetric power dissipation ( $VPD = \rho \cdot g \cdot \Delta H \cdot Q / (B \cdot L \cdot h_0)$ ), where  $\rho$  is the water density and  $B$  is the width of the pool) (FAO/DVWVK, 2002; Towler et al., 2015) or maximum velocity in the cross-wall ( $V_{max} = \sqrt{2 \cdot g \cdot \Delta H}$ ) (Rajaratnam et al., 1986; Larinier, 2002a) can be estimated. Therefore, this method will enable the analysis of the possible consequences in fish passage of different hydraulic scenarios and, thus, it will allow the preliminary evaluation of the passage and detection of possible problems during the whole hydrological period.

In recent years, different equations or equation combinations have been proposed to explain the performance of the discharge coefficient in VSFs under uniform and non-uniform water level profiles (Krüger et al., 2010; Fuentes-Pérez et al., 2014; Marriner et al., 2016). However, all of them present limitations that can be overcome with the use of Eq. 18.

For instance, Krüger *et al.* (2010) proposed the use of a similar equation to Eq. 18 but allowing the constant exponent 1.5 to be adjusted for each VSF subtype (Eq. S4.3 in S4 Appendix). This only provides slightly higher  $R^2$  in the 46% of cases (in the 54% of cases Eq. 18 provides higher  $R^2$ ); however, in the 96% of cases 1.5 is in the 95% of confident interval of the exponent, which consequently seems to indicate that the fit of this variable is unnecessary. Likewise, if the number of free parameters (three against two) is taken into account and the collected data is applied to fit both equations, Eq. 18 will produce better fits in 67% of studied cases ( $BIC_{Eq. 18} <$



$BIC_{Eq. S4.3}$ ) and in 40% of all cases the difference will not be significant ( $|BIC_{Eq. 18} - BIC_{Eq. S4.3}| < 2$ ), which seems to indicate an overfitting problem in the equation proposed by Krüger *et al.* (2010). Moreover, Villemonte's approach enables the comparison of different fishways, as  $\beta_0$  and  $\beta_1$  in Eq. 18 provide, directly, information about hydrodynamic performance.  $\beta_0$  provides information about the horizontal asymptote to be reached by the fit and  $\beta_1$  (indicative of the curvature of the fit) provides information about the evolution of the coefficient with the submergence.

In Fuentes-Pérez *et al.* (2014), as an alternative to the combination of Eq. 15 and Eq. 18, Eq. 16 together with Eq. 18 was suggested for flow estimation in VSFs (e.g. Figure 21(c) and Figure 22(c)). Eq. 16 has been widely recommended by specialized references as it has a physical justification (Clay, 1995; Martínez de Azagra, 1999; Larinier, 2002a; Marriner *et al.*, 2016) and as it collects part of the variability caused by the non-uniform profiles itself (without Eq. 18). This allows a better flow calculation than with Eq. 15 in the first states of non-uniformity when a constant discharge coefficient is used (Figure 22(b)). However, as can be seen from Figure 21(c), 20(b) and 20(c) and Table 8, the use of Eq. 18 is also necessary to collect all the variability produced by non-uniformity and to accurately calculate the flow and water level distribution. When Eq. 18 is used, good results are expected with both equations (Table 8). Nevertheless, the use of Eq. 16 instead of Eq. 15, can also reduce the interpretability of Eq. 18, as the variability due to non-uniformity is distributed in two different equations (Eq. 16 and Eq. 18), instead of only one (Eq. 18).

## Pool and weir fishways

Villemonte's equation was originally proposed for submerged weirs and, therefore, it has been widely used to calculate the flow over PWF. Although Villemonte adjusted the equation for sharp-crested weirs with specific experimental conditions and suggested new fits for different conditions, in practice, the originally proposed coefficients have been indiscriminately used in PWFs (Larinier, 1992; Martínez de Azagra, 1999; FAO/DVWK, 2002). The utility of Eq. 18 and the convenience of specific fits for a PWF subtype has been previously shown in Fuentes-Pérez *et al.* (2016).

The notch of PWFs can perform under two different flow regime conditions, plunging (or free flow) and streaming (or submerged flow), depending on the influence of  $h_2$  over  $h_1$

(Rajaratnam et al., 1988). In the first case,  $h_2 = 0$  ( $h_2' < p$ , see Figure 19) allowing the free flow, while in the later performance  $h_2 > 0$  ( $h_2' > p$ , see Figure 19) and, thus,  $h_2$  slows down the flow due to  $h_1$ . These performances can be found independently or mixed within a fishway. Therefore, the proposed equations must be able to describe both possible conditions.

Usually, and for practical reasons, a constant discharge coefficient is used for notch in plunging performance (Larinier, 1992; Martínez de Azagra, 1999; FAO/DVWK, 2002). This is because the coefficient only changes significantly for low water levels over the sill which is not a typical performance of fishways (Rehbock, 1929; Ead et al., 2004; Fuentes-Pérez et al., 2016). For this reason,  $\beta_0$  in Eq. 18 can be considered as a constant approximation of the free discharge coefficient (when free flow  $h_2/h_1 = 0$  consequently  $C_s = \beta_0$ ) and, thus, Eq. 18 can be used as a general descriptor of plunging and streaming performances. For studies focused on low discharges over fishways, and usually outside their operation range, the use of a variable  $\beta_0$  is recommended (c.f. Fuentes-Pérez et al. (2016)).

PWFs besides a notch also tend to have an orifice, as an alternative passage for fish fauna (Silva et al., 2009; Branco et al., 2013) or to facilitate fishway cleaning (Larinier, 2002a). Thus, the discharge of the orifice must be considered. As previously shown, the  $C_o$  for orifices will be constant. Therefore, 0.876 has been used for  $C_o$  in all field cases to calculate the parameters of Eq. 18. This value is within the coefficient range recommended by specialized references (Martínez de Azagra, 1999; FAO/DVWK, 2002; Larinier, 2002a; Boiten and Dommerholt, 2006) and was calculated for the subtype under study in a systematic field study (Fuentes-Pérez et al., 2016). Nevertheless, appropriate specific constant  $C_o$  values for submerged orifices can be found in Brater et al. (1996).

Considering all of the above, i.e. constant  $C_o$  and  $\beta_0$ , Figure 23 shows the  $C_s$  distribution for the studied PWFs cases. As shown in the figure, considering the  $\beta_1$  proposed by Villemonte ( $\beta_1 = 0.385$ ), as suggested by specialized references, and fitting only  $\beta_0$ , provides a good result; however as recommended by Villemonte, a specific fit offers significant better results ( $R^2$  of 0.755 versus 0.683, RMSE 0.0474 versus 0.0538 and  $BIC_{Eq. 18} < BIC_{Eq. 18, \beta_1 = 0.385}$ ).

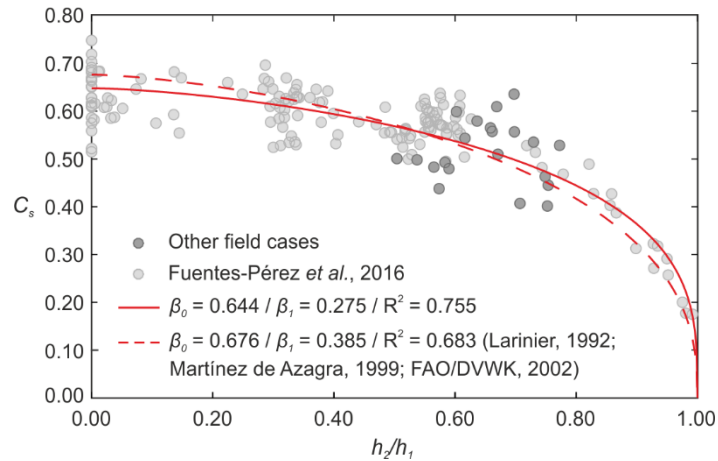

**Figure 23.**  $C_s$  fit for studied PWF and alternative methods proposed by specialized references. In total 180 data points were collected.

The studied field cases involve a  $b$  value for the notch in the range of 0.20 to 0.40 m and a side length for the square orifice in the range of 0.15 to 0.25 m (Table S2.2 in S2 Appendix), which demonstrates the utility of the fit for different notch dimensions. However, all the studied cases have similar configuration (i.e. the flow pattern is similar and therefore they can be considered the same subtype) and, thus, as for the VSF, new fits are recommended for different possible subtypes.

A common alternative calculation to the one described above are the dimensionless relations proposed by Rajaratnam et al. in 1988 (Eqs. S4.4 and S4.5 in S4 Appendix). These equations have been studied and validated in a number of studies (Ead et al., 2004; Yagci, 2010). However, each of the equations proposed by Rajaratnam et al. (1988) is defined for a possible regime (plunging or streaming), not allowing mixed cases. Furthermore, as the dimensionless relations proposed by the same authors for VSFs, they depend on  $S$  and they only consider  $h_0$  as water level descriptor, which does not allow their use for non-uniform profile estimation and generate indeterminations in some cases (e.g.  $S = 0$ ).

## Step-pool nature-like fishway

Most of hydraulic studies on SPNFs have focused on the evaluation of velocity, dissipated energy or friction factors (Pagliara and Chiavaccini, 2006; Wang and Hartlieb, 2011; Oertel and Schlenkhoff, 2012) and, there are no specific studies on discharge and discharge coefficients.

Despite the lack of published studies, design guidelines recommend the use of discharge and discharge coefficient equations. For instance, FAO/DVWK (2002) and Larinier et al. (2006)

recommend the use of the equation for submerged flow in broad-crested weirs. This consists of the use of an equation similar to Eq. 15 together with a drowned-flow reduction factor ( $\sigma$ ) (Schröder, 1994) (Eqs. S4.6 and S4.7 in S4 Appendix) and a reduction constant coefficient ( $\mu$ ) that depends on the geometry of the stones (range from 0.5 to 0.8 if they are sharp-edged or rounded stones respectively (FAO/DVWK, 2002)). In the same way, Hegberg et al. (2001) proposed the use of the equation for sharp-crested weirs of Villemonte (Eq. 15 and Eq. 18 with  $\beta_1 = 0.385$  and a calibrated  $\beta_0$ ). Likewise, due to the small sills that are presented in notches in these kind of configurations (mean  $p = 0.166$  m for the studied case), it is a common practice (FAO/DVWK, 2002; Larinier et al., 2006) to consider for all type of connections same discharge coefficient (i.e. same exponents and coefficients in the discharge coefficient equation).

Figure 24 shows both methods fitted for the field case data in a SPNF together with the fit of Villemonte's equation, where both parameters involved ( $\beta_0$  and  $\beta_1$ ) have been recalculated given the different settings from the ones originally used by the author. As shown by the fit for the broad-crested weir method (FAO/DVWK, 2002; Larinier *et al.*, 2006), it assumes that for situations with  $h_2/h_1 < 0.614$  there is no influence of  $h_2$  in the flow, which does not fit the observed data distribution (RMSE = 0.3433).

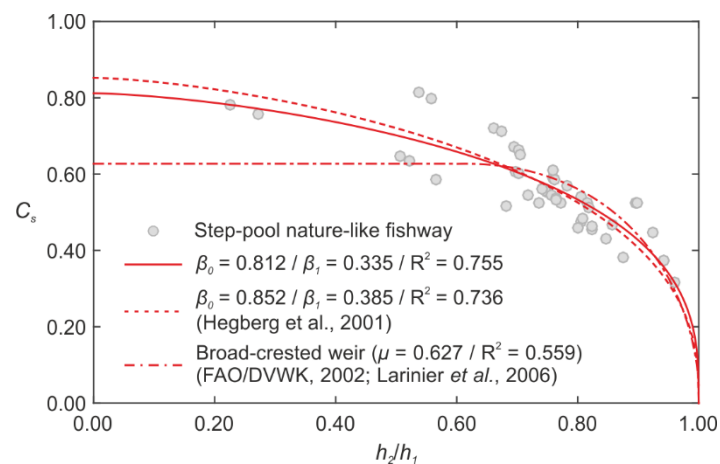

**Figure 24.**  $C_s$  fit for studied PWF and alternative methods proposed by specialized references. In total 180 data points were collected.

When comparing the  $\beta_1$  fitted with that proposed in Villemonte's experiments, as recommended by Hegberg et al. (2001), fitting both parameters provide better significant results (RMSE of 0.0573 versus 0.0583 and  $BIC_{Eq. 18} < BIC_{Eq. 18, \beta_1 = 0.385}$ ) (Figure 24). However, the difference is smaller than the one observed for other fishway types (Figure 23 and Figure

21). This could be explained by the smaller slopes, longer pool length and less turbulence of SPNFs compared with other fishway types, which are closer to the experimental conditions used by Villemonte (without slope ( $S = 0$ ) and  $h_1$  and  $h_2$  measured outside the influence of turbulence). It is noteworthy that the presented result needed to be further studied as only data from one field study has been considered.

In addition, further considerations should be taken into account when overtopping flows occur. In these cases, the cross-walls are completely submerged and the fishway behaves like a channel with continuous roughness in the bottom. Under these conditions, the flow is usually explained by means of relative energy dissipation and friction factors in SPNFs (Oertel and Schlenkhoff, 2012). These variables will depend on the configuration of the boulder arrangements (boulder size, shape and concentration), the slope (Oertel and Schlenkhoff, 2012; Cassan and Laurens, 2016) and also on the submergence ratio (Oertel and Schlenkhoff, 2012; Baki et al., 2014). Likewise, more studies under these experimental conditions are necessary to evaluate the performance of the proposed equations. Nevertheless, these conditions can always be controlled with an adequate design or a control gate upstream of the facility.

## Summary and Conclusions

This article shows how a single equation, Villemonte's equation, can be used to calculate the flow and water level distribution of the most common type of stepped fishways under different boundary conditions, which provides a standardized method for the design and calibration of the performance of these structures. In addition, compared to more extended methods, this equation has shown a better performance not only due to its simplicity, better fit or capacity to unify the different references, but also due to its ability to explain uniform and non-uniform water level profiles with a single equation.

In general, in order to obtain an optimal solution, it seems necessary to estimate both free parameters involved in Eq. 18 ( $\beta_0$  and  $\beta_1$ ), which is understandable given the different experimental conditions used by Villemonte in his original studies.

The possibility of modelling water level distribution in variable boundary conditions provides us with the opportunity to study the variation of hydraulic parameters (e.g.  $VPD$  and  $V_{max}$ ) within the fishway and ensures the fulfilment of fish fauna preferences in different flow

conditions and during the whole hydrological period. Furthermore, if incompatibilities with fish fauna are detected, possible solutions can be tested using the proposed equations. This possibility of optimization in both design and operation will contribute to ensure the longitudinal connectivity in rivers and, thus, facilitate fish migration and species conservation.

In future studies, it would be interesting to validate Villemonte's methodology in other subtypes of fishway, for instance those with non-rectangular shape connections (e.g. triangular, parabolic, etc.).

## Acknowledgements

The authors would like to thank the owners and staff of the hydropower plants and fish farms associated to field cases (SAVASA, Iberdrola, Molinos de Castilla, Comunidad de Regantes de El Carracillo, Junta de Castilla y León, Piscifactoría de Campoo) for their collaboration during the experimental procedures, as well as Dr. Sara Fuentes-Pérez for her editorial advice and active participation in the revision of this paper.

## Notation

The following symbols are used in this paper:

$a$  = orifice height (m)

$B$  = pool width (m)

$b$  = notch, slot or orifice width (m)

$C_o$  = discharge coefficient for orifices (dimensionless)

$C_s$  = discharge coefficient for slots and notches (dimensionless)

$e$  = cross-wall thickness (m)

$g$  = acceleration due to gravity ( $m/s^2$ )

$H$  = total height of the transversal obstacle (m)

$h_0$  = mean water level of the flow in the pool (m)

$h_1$  = mean water level of the flow in the pool upstream of the cross-wall measured from the sill (m)

$h_2$  = mean water level of the flow in the pool downstream of the cross-wall

measured from the sill (m)

$h_1'$  = mean water level of the flow in the pool upstream of the cross-wall ( $h_1' = h_1 + \rho$ ) (m)

$h_2'$  = mean water level of the flow in the pool downstream of the cross-wall ( $h_2' = h_2 + \rho$ ) (m)

$i$  = cross-wall index

$L$  = pool length (m)

$\rho$  = sill height (m)

$Q_1$  = free-flow discharge due to  $h_1$  ( $\text{m}^3/\text{s}$ )

$Q_2$  = counter-flow discharge due to  $h_2$  ( $\text{m}^3/\text{s}$ )

$Q_{design}$  = theoretical discharge or flow, as calculated in the fishway design project ( $\text{m}^3/\text{s}$ )

$Q$  = discharge or flow rate ( $\text{m}^3/\text{s}$ )

$R^2$  = determination coefficient (dimensionless)

$S$  = fishway slope (m/m)

$V_{max}$  = maximum velocity (m/s)

$VPD$  = volumetric power dissipation ( $\text{W}/\text{m}^3$ )

$\beta_0, \beta_1$  = dimensionless coefficients for Eq. 18

$\Delta H$  = water level difference between pools or head drop ( $\Delta H = h_1 - h_2$ ) (m)

$\Delta Z$  = topographic difference between cross-walls (m)

$\rho$  = density of water ( $\text{kg}/\text{m}^3$ )

$\sigma$  = reduction factor for broad-crested weirs (dimensionless)

$\mu$  = reduction constant coefficient for broad-crested weirs (dimensionless)







# **General Conclusions**



## General conclusions

Based on the previous chapters, several general and global conclusions can be reached. These conclusions are logically developed from the cumulative research of the presented compendium of articles and, more than conclude this work, they open the door to further research areas. Some of these possible future researches and their development will be defined in the last section of the thesis.

### Fishway performance

- (1) Non-uniform water level profiles are a natural situation produced by variable boundary conditions of rivers that must be considered in the design and evaluation of fishways and it has the potential to affect the fishway efficiency for fish passage and attraction.
- (2) Non-uniform profiles have the potential to affect all the stepped fishways with variable boundary conditions. For one discharge, only a uniform water level profile exists between many non-uniform ones.
- (3) A non-uniform profile may appear alone in simple designs or mixed in complex structures. Thus, it can be a local or a global situation.
- (4) The defined equations can model to some extent slope variations between cross-walls (chapters 1 and 2). Other geometrical variations (such as length and width of the pool, other singular sections or baffle configuration) could modify the dissipation and recirculation in the pool. This may lead to different discharge coefficient and so produce mixed water level profiles inside the fishway. Such alterations must be considered as different fishway subtypes (chapter 3) and other parameters for their discharge coefficient should be defined.
- (5) Fishways must be analyzed considering all the local geometrical variations as any of these variations may affect their global hydraulic performance.

### Fishway design

- (6) To correctly model the uniform and non-uniform water levels profiles the discharge equation and discharge coefficient involved must consider the correct characterization of the hydraulic variables (boundary conditions).

- (7) The use of discharge coefficients and discharge equations that correctly quantify the water level variability (described in chapters 1,2, and 3) together with an iterative bottom-up calculation (chapter 1) considering the boundary conditions allow the accurate water level modelling of stepped fishways.
- (8) Poleni's discharge equation seems the most reasonable alternative to estimate the discharge through the slots and notches while the discharge equation derived from Torricelli's law is suitable to characterize the discharge through orifices.
- (9) The submerged discharge coefficient defined by Villemonte excels in the calculation of the water levels of slot and notches in stepped fishways.
- (10) For orifices, when using Torricelli's equation, a constant coefficient can be used to describe the observed hydraulic variability.

### **Fishway retrofitting**

- (11) By modelling the water level variability of fishways, it is possible to test their performance during the whole hydrological period. This allows problem detection and solution design during their design phase or after their construction
- (12) By modelling the water levels of fishways and their response to small geometrical alterations it is possible to design specific solutions able to compensate possible local problems (chapter 2).

### **Fishway assessment**

- (13) We propose and validate a general method to model water level profile variability in one dimension for the most common type of stepped fishways, which has direct implications for fishway assessment.
- (14) Simply considering a uniform water level distribution may lead to incorrect or incomplete conclusions particularly in studies carried out over a long-time period. The boundary conditions in the fishway must be considered together with the river hydrograph.
- (15) By considering the effect of non-uniformity in hydraulic variables in fishways, it is possible to calculate its effect on classical variables for fishway assessment (e.g.

maximum velocity or volumetric power dissipation) and, thus, analyze its possible consequences.

- (16) Taken into consideration that usually the assessment of fishways is based on the fishway hydraulics, the effects of non-uniform profiles must also be considered in the modelling of fish response and behavior.





# Future Work





## Future Work

This thesis is not meant as a conclusive work but as a call for attention to highlight the complexity of fishways, the possible design and evaluation problems, and the available opportunities to improve the understanding of these vital structures. Due to this complexity, further research and work will be required.

Many of the conclusions drawn in this thesis have open new avenues of research. One of the first step should be the practical translation of the knowledge presented in this thesis. It is often challenging to incorporate new discoveries and advances into design principles, both (a) because the classical design criteria are deeply rooted and (b) because the broken communication between researchers and engineers. In order to address these issues, we have developed an open source software named *Escalas*. The first *Escalas* version was developed as a proprietary fishway design software based on the well-established design guides (Fuentes-Pérez et al., 2012). However, over time it has become a multipurpose platform for the assisted design, 1D simulation, assessment and correction of stepped fishways. A new version of the software will soon be released as a publication entitled *ESCALAS, an open source software solution to design, model and optimize the performance of stepped fishways (in prep.)*.

During this thesis it has been demonstrated that the proposed 1D approximations can model the most common design situations. However, from a researching view point it would be of interest to test the limits of the proposed methodology, studying extreme cases that could break the assumptions that have been made.

In the same way, non-uniformity is a complex phenomenon that produces alterations of the hydraulic performance at a three-dimensional (3D) level (e.g. alterations of the global recirculation of the pool, velocity and turbulence profiles, etc.). Therefore, to analyse its effect on fish fauna further research is required at this level. In this sense, the synergy between the proposed methods in this thesis and 3D modelling can be of interest, not only to evaluate fishway models performance but also to define correct boundary conditions. The author has advanced on this topic with the publication entitled *3D modelling of non-uniform and turbulent flow in vertical slot fishways*, currently under review, but further research is necessary in this area.

It is worth remembering that the aim of fishways is to allow the free movement of fish and in order to ensure this it is necessary to study the effects of non-uniform water level profiles in fish behaviour and response. In this context, the main areas of interest are the effects of non-uniformity in fish attraction and passage, as non-uniform profiles have the potential to alter the performance in the most downstream cross-wall (most important for attraction), and the possible increase or reduction of velocities and turbulences in the whole structure. Despite the initial research efforts, further study of these is also required.



# **General Acknowledgements**



## General acknowledgements

Firstly, I would like to express my sincere gratitude to my supervisors Prof. Javier Sanz Ronda who gave me the confidence, the knowledge and the liberty to develop myself and, Prof. Andres Martinez de Azagra for the useful discussions and for showing me the important things in life.

Besides my supervisor, I would like to express my thanks to Niti. You have been always there and this work would be impossible without you. Thanks for having the patience, putting me up and for having the ability of making me happy whichever the situation.

My sincere thanks also goes to my family. Thanks to my parents for teaching me that the most important things in life are the experiences and knowledge. Sara, there is no room here to express my thanks to you, you have taught me, you have guided me and you have given me advise, you are one of my role models for many aspects of my life.

Last but not the least, I would like to thank to other members of the GEA and Hydraulic and Hydrology department, Fran, Jorge, the time that I expended with you is unforgettable. Thanks Joaquin for putting me in the track of my researching carrier.





# References





## References

- Alexandre, C.M., Quintella, B.R., Silva, A.T., Mateus, C.S., Romão, F., Branco, P., Ferreira, M.T., Almeida, P.R., 2013. Use of electromyogram telemetry to assess the behavior of the Iberian barbel (*Luciobarbus bocagei* Steindachnert, 1864) in a pool-type fishway. *Ecol. Eng.* 51, 191–202. doi:10.1016/j.ecoleng.2012.12.047
- Baki, A.B.M., Zhu, D.Z., Rajaratnam, N., 2014. Mean flow characteristics in a rock-ramp-type fish pass. *J. Hydraul. Eng.* 140, 156–168. doi:10.1061/(ASCE)HY.1943-7900.0000816
- Bermúdez, M., Puertas, J., Cea, L., Pena, L., Balairón, L., 2010. Influence of pool geometry on the biological efficiency of vertical slot fishways. *Ecol. Eng.* 36, 1355–1364. doi:10.1016/j.ecoleng.2010.06.013
- Bice, C.M., Zampatti, B.P., Mallen-Cooper, M., 2017. Paired hydraulically distinct vertical-slot fishways provide complementary fish passage at an estuarine barrier. *Ecol. Eng.* 98, 246–256. doi:10.1016/j.ecoleng.2016.11.001
- Boiten, W., Dommerholt, A., 2006. Standard design of the Dutch pool and orifice fishway. *Int. J. River Basin Manag.* 4, 219–227. doi:10.1080/15715124.2006.9635291
- Branco, P., Santos, J.M., Katopodis, C., Pinheiro, A., Ferreira, M.T., 2013. Pool-Type Fishways: Two Different Morpho-Ecological Cyprinid Species Facing Plunging and Streaming Flows. *PLoS One* 8, e65089. doi:10.1371/journal.pone.0065089
- Branco, P., Segurado, P., Santos, J.M., Pinheiro, P., Ferreira, M.T., 2012. Does longitudinal connectivity loss affect the distribution of freshwater fish? *Ecol. Eng.* 48, 70–78. doi:10.1016/j.ecoleng.2011.05.008
- Brater, E.F., King, H.W., Lindell, J.E., Wei, C.Y., 1996. *Handbook of hydraulics*. McGraw Hill, Boston, Massachusetts, USA.
- Bunt, C.M., Castro-Santos, T., Haro, A., 2016. Reinforcement and Validation of the Analyses and Conclusions Related to Fishway Evaluation Data from Bunt et al.: “Performance of Fish Passage Structures at Upstream Barriers to Migration.” *River Res. Appl.* 32, 2125–2137. doi:10.1002/rra.3095
- Bunt, C.M., Castro-Santos, T., Haro, A., Castro-Santos, T., Haro, A., Castro-Santos, T., Haro, A., 2012. Performance of fish passage structures at upstream barriers to migration. *River*

Res. Appl. 28, 457–478. doi:10.1002/rra.1565

- Calluad, D., Cornu, V., Bourtal, B., Dupuis, L., Refin, C., Courret, D., David, L., 2012. Scale effects of turbulence flows in vertical slot fishways: field and laboratory measurement investigation, in: 9th International Symposium on Ecohydraulics. Vienna, p. Austria.
- Cassan, L., Laurens, P., 2016. Design of emergent and submerged rock-ramp fish passes. Knowl. Manag. Aquat. Ecosyst. 45. doi:10.1051/kmae/2016032
- Cea, L., Pena, L., Puertas, J., Vázquez-Cendón, M.E., Peña, E., 2007. Application of several depth-averaged turbulence models to simulate flow in vertical slot fishways. J. Hydraul. Eng. 133, 160–172. doi:10.1061/(ASCE)0733-9429(2007)133:2(160)
- Chow, V. Te, 2004. Hidráulica de canales abiertos. McGraw Hill, Santafé de Bogotá (Colombia).
- Clay, C.H., 1995. Design of fishways and other fish facilities. CRC Press, Ottawa, Canada.
- Cooke, S.J., Hinch, S.G., 2013. Improving the reliability of fishway attraction and passage efficiency estimates to inform fishway engineering, science, and practice. Ecol. Eng. 58, 123–132. doi:10.1016/j.ecoleng.2013.06.005
- Ead, S.A., Katopodis, C., Sikora, G.J., Rajaratnam, N., 2004. Flow regimes and structure in pool and weir fishways. J. Environ. Eng. Sci. 3, 379–390. doi:10.1139/s03-073
- Elvira, B., Nicola, G.G., Almodóvar, A., 1998. Sistemas de paso para peces en presas. CEDEX, Ministerio de Fomento, Madrid (Spain).
- Enders, E.C., Boisclair, D., Roy, A.G., 2005. A model of total swimming costs in turbulent flow for juvenile Atlantic salmon (*Salmo salar*). Can. J. Fish. Aquat. Sci. 62, 1079–1089. doi:10.1139/f05-007
- European Commission, 2000. Directive 2000/60/EC of the European Parliament and of the Council establishing a framework for the Community action in the field of water policy.
- FAO/DVWK, 2002. Fish Passes: Design, Dimensions, and Monitoring. FAO, Rome, Italy.
- Fuentes-Pérez, J.F., 2012. Desarrollo de una base metodológica para el diseño de escalas de artesas. Aplicación práctica en un programa informático. ETSIIAA, Universidad de Valladolid, Palencia (España).
- Fuentes-Pérez, J.F., García-Vega, A., Sanz-Ronda, F.J., Martínez de Azagra-Paredes, A., 2017a.

- Villemonte's approach: validation of a general method for modeling uniform and non-uniform performance in stepped fishways. *Knowl. Manag. Aquat. Ecosyst.* 418, 11. doi:10.1051/kmae/2017013
- Fuentes-Pérez, J.F., Sanz-Ronda, F.J., Martínez de Azagra-Paredes, A., García-Vega, A., 2018. ESCALAS, an open source software solution to design, model and optimize the performance of stepped fishways (in prep.).
- Fuentes-Pérez, J.F., Sanz-Ronda, F.J., Martínez de Azagra-Paredes, A., García-Vega, A., Martínez de Azagra, A., García-Vega, A., 2016. Non-uniform hydraulic behavior of pool-weir fishways: a tool to optimize its design and performance. *Ecol. Eng.* 86, 5–12. doi:10.1016/j.ecoleng.2015.10.021
- Fuentes-Pérez, J.F., Sanz-Ronda, F.J., Martínez de Azagra Paredes, A., García-Vega, A., 2014. Modeling Water-Depth Distribution in Vertical-Slot Fishways under Uniform and Nonuniform Scenarios. *J. Hydraul. Eng.* 140, 6014016. doi:10.1061/(ASCE)HY.1943-7900.0000923
- Fuentes-Pérez, J.F., Silva, A.T., Tuhtan, J.A., García-Vega, A., Carbonell-Baeza, R., Musall, M., Kruusmaa, M., 2017b. 3D modelling of non-uniform and turbulent flow in vertical slot fishways (under review). *Environ. Model. Softw.*
- García-Vega, A., Sanz-Ronda, F.J., Fuentes-Pérez, J.F., 2017. Seasonal and daily upstream movements of brown trout *Salmo trutta* in an Iberian regulated river. *Knowl. Manag. Aquat. Ecosyst.* 418, 9. doi:10.1051/kmae/2016041
- Gasith, A., Resh, V.H., 1999. Streams in Mediterranean climate regions: abiotic influences and biotic responses to predictable seasonal events. *Annu. Rev. Ecol. Syst.* 30, 51–81. doi:10.1146/annurev.ecolsys.30.1.51
- Goettel, M.T., Atkinson, J.F., Bennett, S.J., 2015. Behavior of western blacknose dace in a turbulence modified flow field. *Ecol. Eng.* 74, 230–240. doi:10.1016/j.ecoleng.2014.10.012
- Graf, W.L., 2006. Downstream hydrologic and geomorphic effects of large dams on American rivers. *Geomorphology* 79, 336–360. doi:10.1016/j.geomorph.2006.06.022
- Hegberg, C.H., Jacobs, S., Schlindwein, P.A., Cohen, S.J., 2001. *Fish Passage in Urban Streams*

- Part 2: Natural Channel Design Methods. *Wetl. Eng. River Restor.* 1–12.  
doi:10.1061/40581(2001)17
- IUCN, 2017. IUCN Red List of threatened species, The IUCN Red List of Threatened Species.<<http://www.iucnredlist.org>>.
- Kamula, R., 2001. Flow over weirs with application to fish passage facilities. Oulun yliopisto, Finlandia.
- Kass, R.E., Wasserman, L., 1995. A reference Bayesian test for nested hypotheses and its relationship to the Schwarz criterion. *J. Am. Stat. Assoc.* 90, 928–934.  
doi:10.1080/01621459.1995.10476592
- Katopodis, C., Williams, J.G., 2012. The development of fish passage research in a historical context. *Ecol. Eng.* 48, 8–18. doi:<http://dx.doi.org/10.1016/j.ecoleng.2011.07.004>
- Kilpatrick, F.A., Cobb, E.D., 1985. Measurement of discharge using tracers. USGPO,.
- Kim, J.H., 2001. Hydraulic characteristics by weir type in a pool-weir fishway. *Ecol. Eng.* 16, 425–433. doi:10.1016/S0925-8574(00)00125-7
- Krüger, F., Heimerl, S., Seidel, F., Lehmann, B., 2010. Ein Diskussionsbeitrag zur hydraulischen Berechnung von Schlitzpässen. *WasserWirtschaft* 3, 31–36. doi:10.1007/BF03241596
- Larinier, M., 2008. Fish passage experience at small-scale hydro-electric power plants in France. *Hydrobiologia* 609, 97–108. doi:10.1007/s10750-008-9398-9
- Larinier, M., 2002a. Pool fishways, pre-barrages and natural bypass channels. *Bull. Fr. Pêche Piscic.* 364, 54–82. doi:10.1051/kmae/2002108
- Larinier, M., 2002b. Location of fishways. *Bull. Fr. Pêche Piscic.* 364, 39–53. doi:10.1051/kmae/2002106
- Larinier, M., 2002c. Biological factors to be taken into account in the design of fishways, the concept of obstructions to upstream migration. *Bull. Fr. Pêche Piscic.* 364, 28–38. doi:10.1051/kmae/2002105
- Larinier, M., 2001. Environmental issues, dams and fish migration, in: Marmulla, G. (Ed.), *Dams, Fish and Fisheries: Opportunities, Challenges and Conflict Resolution*. FAO Fisheries Technical Paper N° 419. Food & Agriculture Organization of the United Nations

- (FAO), Rome, pp. 45–89.
- Larinier, M., 1992. Passes à bassins successifs, prébarrages et rivières artificielles. Bull. Français la Pêche la Piscic. 45–72. doi:10.1051/kmae:1992005
- Larinier, M., Courret, D., Gomes, P., 2006. Guide technique pour la conception des passes à poissons “naturelles”. Rapport GHAAPPE RA.06.05-V1. Agence de l’Eau Adour Garonne, Compagnie Nationale du Rhône, Conseil Supérieur de la Pêche, Groupe d’Hydraulique Appliquée aux Aménagements Piscicoles et à la Protection de l’Environnement, Institut de mécanique des fluides de Toulouse, 66 p. doi:10.13140/RG.2.1.1834.8562
- Lasne, E., Lek, S., Laffaille, P., 2007. Patterns in fish assemblages in the Loire floodplain: the role of hydrological connectivity and implications for conservation. Biol. Conserv. 139, 258–268. doi:10.1016/j.biocon.2007.07.002
- Liu, M., Rajaratnam, N., Zhu, D.Z., 2006. Mean flow and turbulence structure in vertical slot fishways. J. Hydraul. Eng. 132, 765–777. doi:10.1061/(ASCE)0733-9429(2006)132:8(765)
- Lucas, M.C., Baras, E., Thom, T.J., Duncan, A., Slavík, O., 2001. Migration of freshwater fishes. Wiley Online Library, Oxford, UK. doi:10.1002/9780470999653.fmatter
- Lupandin, A.I., 2005. Effect of flow turbulence on swimming speed of fish. Biol. Bull. 32, 461–466. doi:10.1007/s10525-005-0125-z
- Marriner, B.A., Baki, A.B.M., Zhu, D.Z., Cooke, S.J., Katopodis, C., 2016. The hydraulics of a vertical slot fishway: A case study on the multi-species Vianney-Legendre fishway in Quebec, Canada. Ecol. Eng. 90, 190–202. doi:10.1016/j.ecoleng.2016.01.032
- Martínez, E., 2001. Hidráulica fluvial: principios y práctica. Bellisco, Madrid (Spain).
- Martínez de Azagra, A., 1999. Escalas para peces. ETSIIAA, Universidad de Valladolid, Palencia, Spain.
- Moher, D., Liberati, A., Tetzlaff, J., Altman, D.G., The PRISMA Group, 2009. Preferred Reporting Items for Systematic Reviews and Meta-Analyses: The PRISMA Statement. PLoS Med 6, e1000097. doi:10.1371/journal.pmed.1000097
- Musall, M., Oberle, P., Carbonell-Baeza, R., Fuentes-Pérez, J.F., Tuhtan, J.A., Nestmann, F., 2015. Beitrag zu detaillierten Analysen der Hydraulik von Schlitzpässen. WasserWirtschaft 7/8, 67–71. doi:10.1007/s35147-015-0551-x

- Nilsson, C., Reidy, C.A., Dynesius, M., Revenga, C., 2005. Fragmentation and flow regulation of the world's large river systems. *Science* 308, 405–408. doi:10.1126/science.1107887
- Oertel, M., Schlenkhoff, A., 2012. Crossbar block ramps: Flow regimes, energy dissipation, friction factors, and drag forces. *J. Hydraul. Eng.* 138, 440–448. doi:10.1061/(ASCE)HY.1943-7900.0000522
- Pagliara, S., Chiavaccini, P., 2006. Flow resistance of rock chutes with protruding boulders. *J. Hydraul. Eng.* 132, 545–552. doi:10.1061/(ASCE)0733-9429(2006)132:6(545)
- Pena, L., 2004. Estudio hidráulico en modelo de escalas de peixes de fenda vertical e de fenda profunda aliñadas. Aproximación á avaliación experimental da enerxía cinética turbulenta. *Estud. hidráulico en Model. escalas peixes fenda Vert. e fenda profunda aliñadas. Aproximación á avaliación Exp. da enerxía cinética Turbul.* Tese de Doutoramento, Programa de Doutoramento de Enxeñería Civil, Universidade da Coruña.
- Poleni, G., 1717. *De motu aquae mixto libri duo*, Padova: G. Comini; VII, 132 p.; in 8.; DCC.4.24. Iosephi Comini, Patavii.
- Porcher, J.P., Travade, F., 2002. Fishways: biological basis, limits and legal considerations. *Bull. Français la Pêche la Piscic.* 364, 9–20. doi:10.1051/kmae/2002110
- Priestley, M.B., 1981. *Spectral analysis and time series*. Academic press, London, UK.
- Puertas, J., Cea, L., Bermúdez, M., Pena, L., Rodríguez, Á., Rabuñal, J.R., Balairón, L., Lara, Á., Aramburu, E., 2012. Computer application for the analysis and design of vertical slot fishways in accordance with the requirements of the target species. *Ecol. Eng.* 48, 51–60. doi:10.1016/j.ecoleng.2011.05.009
- Puertas, J., Pena, L., Teijeiro, T., 2004. Experimental approach to the hydraulics of vertical slot fishways. *J. Hydraul. Eng.* 130, 10–23. doi:10.1061/(ASCE)0733-9429(2004)130:1(10)
- Quaresma, A.L., Ferreira, R.M.L., Pinheiro, A.N., 2017. Comparative analysis of particle image velocimetry and acoustic Doppler velocimetry in relation to a pool-type fishway flow. *J. Hydraul. Res.* 1–10.
- R Core Team, 2016. *R: A language and environment for statistical computing*. R Foundation for Statistical Computing, Vienna, Austria, Austria.
- Rajaratnam, N., Katopodis, C., 1984. Hydraulics of Denil fishways. *J. Hydraul. Eng.* 110, 1219–

1233. doi:10.1061/(ASCE)0733-9429(1984)110:9(1219)
- Rajaratnam, N., Katopodis, C., Mainali, A., 1989. Pool-orifice and pool-orifice-weir fishways. *Can. J. Civ. Eng.* 16, 774–777. doi:10.1139/l89-112
- Rajaratnam, N., Katopodis, C., Mainali, A., 1988. Plunging and streaming flows in pool and weir fishways. *J. Hydraul. Eng.* 114, 939–944. doi:10.1061/(ASCE)0733-9429(1988)114:8(939)
- Rajaratnam, N., Katopodis, C., Solanki, S., 1992. New designs for vertical slot fishways. *Can. J. Civ. Eng.* 19, 402–414. doi:10.1139/l92-049
- Rajaratnam, N., Van der Vinne, G., Katopodis, C., 1986. Hydraulics of vertical slot fishways. *J. Hydraul. Eng.* 112, 909–927. doi:10.1061/(ASCE)0733-9429(1986)112:10(909)
- Rehbock, T., 1929. Wassermessung mit scharfkantigen Überfallwehren. *Z. Ver. dtsh. Ing.* 73, 817–823.
- Romão, F., Quaresma, A.L., Branco, P., Santos, J.M., Amaral, S., Ferreira, M.T., Katopodis, C., Pinheiro, A.N., 2017. Passage performance of two cyprinids with different ecological traits in a fishway with distinct vertical slot configurations. *Ecol. Eng.* 105, 180–188.
- Roscoe, D.W., Hinch, S.G., 2010. Effectiveness monitoring of fish passage facilities: historical trends, geographic patterns and future directions. *Fish Fish.* 11, 12–33. doi:10.1111/j.1467-2979.2009.00333.x
- Santos, J.M., Branco, P., Katopodis, C., Ferreira, T., Pinheiro, A., 2014. Retrofitting pool-and-weir fishways to improve passage performance of benthic fishes: Effect of boulder density and fishway discharge. *Ecol. Eng.* 73, 335–344. doi:10.1016/j.ecoleng.2014.09.065
- Santos, J.M., Branco, P.J., Silva, A.T., Katopodis, C., Pinheiro, A.N., Viseu, T., Ferreira, M.T., 2013. Effect of two flow regimes on the upstream movements of the Iberian barbel (*Luciobarbus bocagei*) in an experimental pool-type fishway. *J. Appl. Ichthyol.* 29, 425–430. doi:10.1111/jai.12043
- Santos, J.M., Silva, A., Katopodis, C., Pinheiro, P., Pinheiro, A., Bochechas, J., Ferreira, M.T., 2012. Ecohydraulics of pool-type fishways: getting past the barriers. *Ecol. Eng.* 48, 38–50. doi:10.1016/j.ecoleng.2011.03.006
- Sanz-Ronda, F.J., Bravo-Cordoba, F.J., Fuentes-Pérez, J.F., Castro-Santos, T., 2016. Ascent

- ability of brown trout, *Salmo trutta*, and two Iberian cyprinids - Iberian barbel, *Luciobarbus bocagei*, and northern straight-mouth nase, *Pseudochondrostoma duriense* - in a vertical slot fishway. Knowl. Manag. Aquat. Ecosyst. 417, 10. doi:10.1051/kmae/2015043
- Sanz-Ronda, F.J., Bravo-Córdoba, F.J., Fuentes-Pérez, J.F., Ruiz-Legazpi, J., García-Vega, A., Ramos-González, N., Salgado-González, V.M., Martínez de Azagra Paredes, A., 2013. PASOS PARA PECES : escalas y otros dispositivos de paso. Notas técnicas del CIREF 7, 17.
- Sanz-Ronda, F.J., Bravo-Córdoba, F.J., Ruiz-Legazpi, J., Fuentes-Pérez, J.F., 2015a. The most evaluated fishway in Spain: a new lesson every year, in: Fish Passage 2015. International Conference on River Connectivity Best Practices and Innovations. Groningen, The Netherlands, pp. 146–147.
- Sanz-Ronda, F.J., Fuentes-Pérez, J.F., García-Vega, A., 2010. Solution to the fish migration problem in the weir “La Flecha”, Tormes River (Salamanca Spain). ETSIIAA, Universidad de Valladolid, Palencia (Spain).
- Sanz-Ronda, F.J., Ruiz-Legazpi, J., Bravo-córdoba, F.J., Makrakis, S., Castro-Santos, T., 2015b. Sprinting performance of two Iberian fish: *Luciobarbus bocagei* and *Pseudochondrostoma duriense* in an open channel flume. Ecol. Eng. 83, 61–70. doi:10.1016/j.ecoleng.2015.05.033
- Schröder, R.C.M., 1994. Technische Hydraulik: Kompendium für den Wasserbau. Springer - Verlag Berlin Heidelberg. doi:10.1007/978-3-662-13100-8
- Silva, A.T., Katopodis, C., Santos, J.M., Ferreira, M.T., Pinheiro, A.N., 2012. Cyprinid swimming behaviour in response to turbulent flow. Ecol. Eng. 44, 314–328. doi:10.1016/j.ecoleng.2012.04.015
- Silva, A.T., Santos, J.M., Ferreira, M.T., Pinheiro, A.N., Katopodis, C., 2012. Passage efficiency of offset and straight orifices for upstream movements of Iberian barbel in a pool-type fishway. River Res. Appl. 28, 529–542. doi:10.1002/rra.1465
- Silva, A.T., Santos, J.M., Ferreira, M.T., Pinheiro, A.N., Katopodis, C., 2011. Effects of water velocity and turbulence on the behaviour of Iberian barbel (*Luciobarbus bocagei*, Steindachner 1864) in an experimental pool-type fishway. River Res. Appl. 27, 360–373. doi:10.1002/rra.1363



- Silva, A.T., Santos, J.M., Franco, A.C., Ferreira, M.T., Pinheiro, A.N., 2009. Selection of Iberian barbel *Barbus bocagei* (Steindachner, 1864) for orifices and notches upon different hydraulic configurations in an experimental pool-type fishway. *J. Appl. Ichthyol.* 25, 173–177. doi:10.1111/j.1439-0426.2009.01237.x
- Spanish Water Law, 2001. Real Decreto Legislativo 1/2001, por el que se aprueba el Texto Redifundido de la Ley de Aguas. BOE 176, 26791–26817.
- Tarrade, L., Pineau, G., Calluau, D., Texier, A., David, L., Larinier, M., 2011. Detailed experimental study of hydrodynamic turbulent flows generated in vertical slot fishways. *Environ. fluid Mech.* 11, 1–21. doi:10.1007/s10652-010-9198-4
- Torricelli, E., 1644. *Opera geometrica*. Amadoro Massa & Lorenzo de Landis, Florence, Italy.
- Towler, B., Mulligan, K., Haro, A., 2015. Derivation and application of the energy dissipation factor in the design of fishways. *Ecol. Eng.* 83, 208–217. doi:10.1016/j.ecoleng.2015.06.014
- Villemonte, J.R., 1947. Submerged-weir discharge studies. *Eng. News-Record* 139, 866–869.
- Wang, R.W., 2008. Aspects of design and monitoring of nature-like fish passes and bottom ramps. Tech. Univ. München. Technische Universität München., München (Germany).
- Wang, R.W., David, L., Larinier, M., 2010. Contribution of experimental fluid mechanics to the design of vertical slot fish passes. *Knowl. Manag. Aquat. Ecosyst.* 396, 1–21. doi:10.1051/kmae/2010002
- Wang, R.W., Hartlieb, A., 2011. Experimental and field approach to the hydraulics of nature-like pool-type fish migration facilities. *Knowl. Manag. Aquat. Ecosyst.* 400, 1–18. doi:10.1051/kmae/2011001
- Williams, J.G., Armstrong, G., Katopodis, C., Larinier, M., Travade, F., 2012. Thinking like a fish: a key ingredient for development of effective fish passage facilities at river obstructions. *River Res. Applic.* 28, 407–417. doi:10.1002/rra.1551
- Wu, S., Rajaratnam, N., Katopodis, C., 1999. Structure of flow in vertical slot fishway. *J. Hydraul. Eng.* 125, 351–360. doi:10.1061/(ASCE)0733-9429(1999)125:4(351)
- Yagci, O., 2010. Hydraulic aspects of pool-weir fishways as ecologically friendly water structure. *Ecol. Eng.* 36, 36–46. doi:10.1016/j.ecoleng.2009.09.007





# **Annex 1. Abstract in Spanish**



## **Annex 1. Abstract in Spanish**

### **Modelización de pasos para peces ante diferentes escenarios hidrodinámicos**

Muchas especies de peces, con el fin de completar sus ciclos vitales, necesitan realizar desplazamientos longitudinales a lo largo de los ríos. Por ello, son uno de los grupos de animales más afectados por el uso intensivo que el ser humano hace de los ríos. Entre otros impactos, la instalación de obstáculos transversales en ríos es una de las alteraciones más importantes que afectan a los movimientos piscícolas.

La mejor solución a la hora de recuperar el libre movimiento de los peces es la eliminación del obstáculo. Sin embargo, en muchos casos, los beneficios sociales que acompañan a estas estructuras hacen imposible su eliminación, y a menudo, la única forma de recuperar la continuidad longitudinal es la construcción de pasos para peces (también llamados escalas para peces).

Existen muchos tipos de pasos para peces. Sin embargo, y dada su versatilidad y habilidad para adaptarse a un amplio rango de obstáculos, las escalas para peces de estanques sucesivos son la solución más común. A pesar de que se trata de una solución atractiva y bastante eficaz para recuperar el libre movimiento de los peces, este tipo de escalas son muy sensibles a las variaciones naturales que se producen en los ríos, y su funcionamiento puede verse fácilmente alterado por las variaciones de las condiciones de contorno de los ríos, especialmente marcadas en regiones mediterráneas.

Esta tesis es un estudio sistemático de dicha variabilidad de las condiciones de contorno en escalas para peces de estanques sucesivos. Así pues, se ha estudiado el comportamiento hidráulico de diferentes tipos y subtipos de escalas para peces de estanques sucesivos, teniendo en cuenta las metodologías de cálculo existente más extendidas, determinando sus limitaciones y proponiendo nuevos métodos de cálculo que permitan cubrir esta variabilidad hidráulica. Para ello, se han considerado tanto estudios en campo bajo diferentes condiciones de contorno como casos especializados de la literatura. El resultado es una metodología general para la modelización de los niveles de agua en escalas para peces de estanques sucesivos bajo condiciones de contorno variables.

Esta metodología permite considerar la variabilidad natural de los ríos tanto en los proyectos de diseño de escalas para peces, lo que asegurara tanto su correcto funcionamiento a lo largo de todo el año hidrológico, como la optimización del funcionamiento en escalas para peces ya existentes. Así mismo, también permite considerar el efecto de los cambios hidrológicos sobre las escalas para peces y su impacto sobre la ictiofauna en estudios biológicos de larga duración, lo que generara resultados y conclusiones más reales y relevantes.



# **Annex 2. Supplementary material of chapter 3**





## S1 Appendix. Search strategy

The article selection and classification was conducted by two researchers in parallel, discussing possible discrepancies and disagreements. The following steps summarize the systematic data extraction strategy:

- a) **Identification:** use of different search engines and databases via different search criteria to find target scientific works.
- b) **Screening:** removal of duplicates and preliminary exclusion. During a preliminary exclusion round studies which results did not relate to the design, characterization or performance of stepped fishways (e.g. non related subjects, other fishway types or biological evaluations) were removed.
- c) **Eligibility:** During a second exclusion round, studies which results focused exclusively in the design but without data or those focused in hydraulic modeling with computational fluid dynamics (CFD) methods and without real data comparison were removed.
- d) **Inclusion:** final choice of results and quality assessment. Only those studies with real and raw data, an appropriate geometrical description of the structures and variables were considered. Thus, works with insufficient data, with an inappropriate description or included in other studies were removed.

### Vertical slot fishways

**Database:** Google Scholar (GS), Web of Science (WoS) and Scopus (SC). Web of Science includes the following databases as part of the FECYT Consortium Academic Group subscription: Web of Science™ Core Collection, KCI-Korean Journal Database, MEDLINE®, Russian Science Citation Index and SciELO Citation Index.

**Dates:** GS: 7 June 2016; WoS: 15 September 2016; SC: 19 September 2016

**Search:** ((Vertical slot fishway) && (discharge equation || discharge coefficient || hydraulic performance || uniform flow || non-uniform flow || Villemonte || water depth distribution)) || (Vertical slot && hydraulic calculation)

**Number of results after database integration (Fig. S1.1): 175**

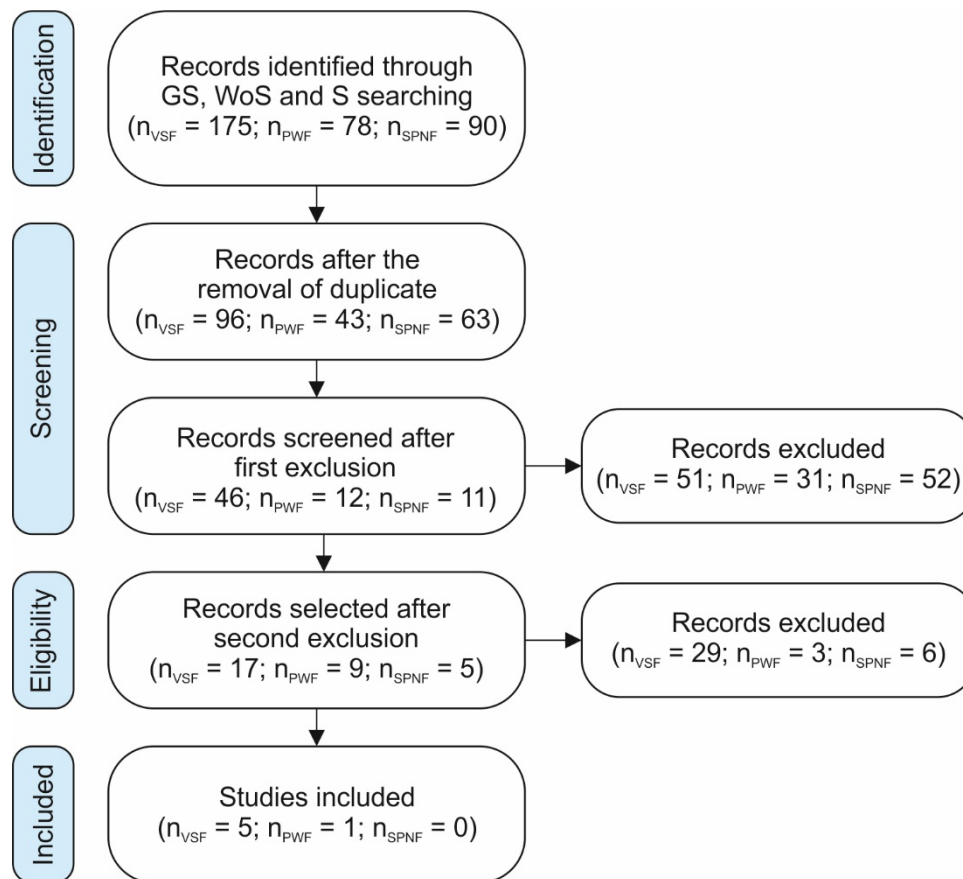

**Figure S1.1.** search flow diagram for all fishway typologies. n represents the results in each phase of the literature search.

## Pool and Weir fishways

**Database:** Google Scholar (GS), Web of Science (WoS) and Scopus (SC). Web of Science includes the following databases as part of the FECYT Consortium Academic Group subscription: Web of Science™ Core Collection, KCI-Korean Journal Database, MEDLINE®, Russian Science Citation Index and SciELO Citation Index.

**Date:** GS: 11 June 2016; WoS: 15 September 2016; SC: 19 September 2016

**Search:** ((pool-weir fishway) && (discharge equation || discharge coefficient || hydraulic performance || uniform flow || non-uniform flow || Villemonte || water depth distribution)) || ((pool and weir fishway) && (discharge equation || discharge coefficient || hydraulic performance || uniform flow || non-uniform flow || Villemonte || water depth distribution)) || (pool and weir && hydraulic calculation)

**Number of results after database integration (Fig. S1.1):** 78

## Step-pool natural-like fishways

**Database:** Google Scholar (GS), Web of Science (WoS) and Scopus (SC). Web of Science includes the following databases as part of the FECYT Consortium Academic Group subscription: Web of Science™ Core Collection, KCI-Korean Journal Database, MEDLINE®, Russian Science Citation Index and SciELO Citation Index.

**Date:** GS: 13 June 2016; WoS: 15 September 2016; S: 19 September 2016

**Search:** ((natural-like fishway) && (discharge equation || discharge coefficient || hydraulic performance || uniform flow || non-uniform flow || Villemonte || water depth distribution)) || (natural-like fishway) || (pool and riffle fishway)

**Number of results after database integration (Fig. S1.1):** 90

## S2 Appendix. Field case studies

### 1. Vertical slot fishways

Fig. S2.1 shows the plan view of the VSFs studied and Tab. S2.1 the main dimensions of each. Geometrical variables involved in all the calculus are defined in Fig. S2.2. It is worth mentioning that VSF2 is a mixed fishway, following the design of both a VSF and a PWF, but for this study only the VSF side has been considered.

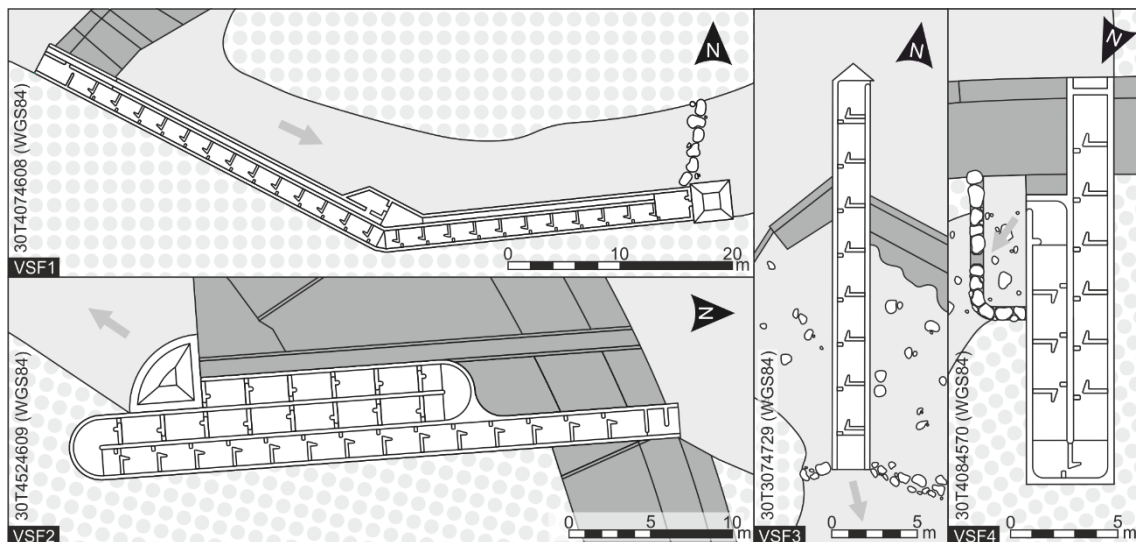

**Figure S2.1.** Vertical slot fishways studied in field. VSF1: Vegas del Condado fishway; VSF2: Peñafiel fishway; VSF3: Vegas del Condado fish farm fishway; VSF4: Carracillo fishway.

**Table S2.1.** Mean values of principal dimensions of VSFs. All the symbols are defined in the notation section.

Fishway	$b$ (m)	$B$ (m)	$e$ (m)	$L$ (m)	$S$ (m/m)	$\Delta Z$ (m)	$Q_{design}$ (m <sup>3</sup> /s)
VSF1	0.200	1.600	0.200	2.100	0.062	0.143	0.278
VSF2	0.200	1.600	0.200	2.100	0.082	0.183	0.278
VSF3	0.216	1.600	0.200	2.400	0.068	0.177	0.317
VSF4	0.195	1.600	0.200	2.100	0.057	0.130	0.278

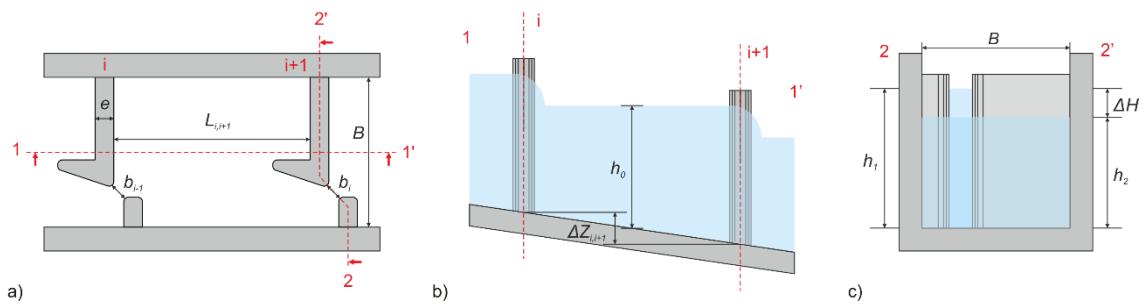

**Figure S2.2.** VSF sketch. Schematic representation of a VSF and definition of all the variables involved. a) Plant. b) Longitudinal section. c) Cross section. All the symbols are defined in the notation section.

## 2. Pool and weir fishways

Fig. S2.3 shows the plan view of the PWFs studied and Tab. S2.2 the main dimensions of each. Geometrical variables involved in all the calculus are defined in Fig. S2.4. Please note that PWF3 has two entrances; the two independent sections converge into one, each of which have their own dimensions.

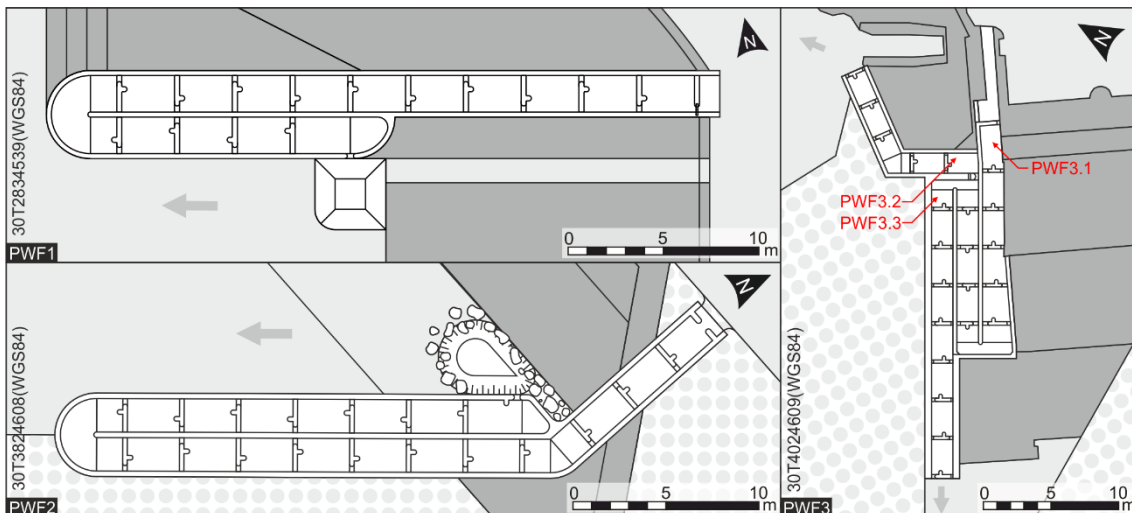

**Figure S2.3.** Pool and weir fishways studied in field. PWF1: La Fecha fishway; PWF2: Sardón de Duero fishway; PWF3: Josefina fishway.

**Table S2.2.** Mean values of principal dimensions of PWFs. All the symbols are defined in the notation section.

Fishway	$a$ (m)	$b_{orifice}$ (m)	$b_{notch}$ (m)	$p$ (m)	$B$ (m)	$e$ (m)	$L$ (m)	$S$ (m/m)	$\Delta Z$ (m)	$Q_{design}$ (m <sup>3</sup> /s)
PWF1	0.191	0.197	0.310	0.917	1.800	0.250	2.600	0.087	0.247	0.278
PWF2	0.250	0.250	0.300	0.750	1.800	0.250	2.600	0.078	0.223	0.357
PWF3.1	0.250	0.250	0.400	0.656	2.000	0.200	2.600	0.093	0.260	0.395
PWF3.2	0.150	0.150	0.200	0.707	2.000	0.200	2.600	0.092	0.240	0.180
PWF3.3	0.150	0.150	0.250	0.628	2.000	0.200	2.600	0.080	0.225	0.215

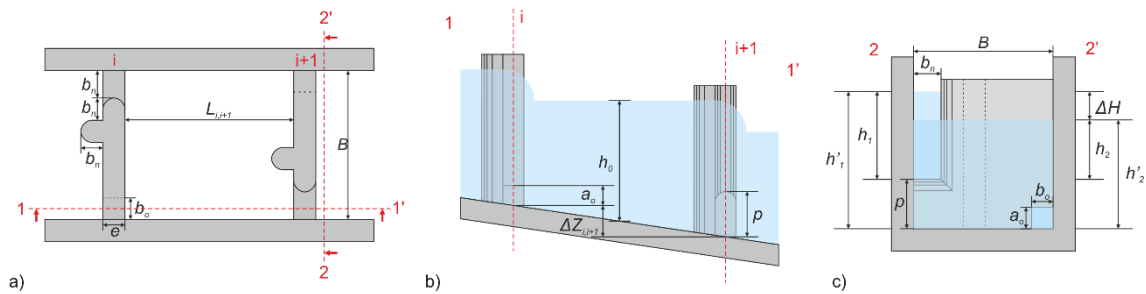

**Figure S2.4.** PWF sketch. Schematic representation of a PWF and definition of all the variables involved. a) Plant. b) Longitudinal section. c) Cross section. All the symbols are defined in the notation section.

### 3. Step-pool natural-like fishway

The SPNF consists on a bypass channel with 5 stone cross-walls or barrages with a  $Q_{design}$  of 0.400 m<sup>3</sup>/s (Fig. S2.5). Each of the cross-walls has 2 notches (mean  $b_{notch} = 0.207$  m and mean  $p = 0.166$  m) and 1 slot (mean  $b_{slot} = 0.208$  m). Regarding the pool dimensions, pools have a mean  $L$  of 4.765 m, a mean  $B$  of 2.712 m, a mean  $e$  of 0.920 m and a mean  $\Delta Z$  of 0.166m, which is translated into a slope of 0.029 m/m. Likewise, the notches and slots are situated alternatively, i.e. a slot never faces another slot.

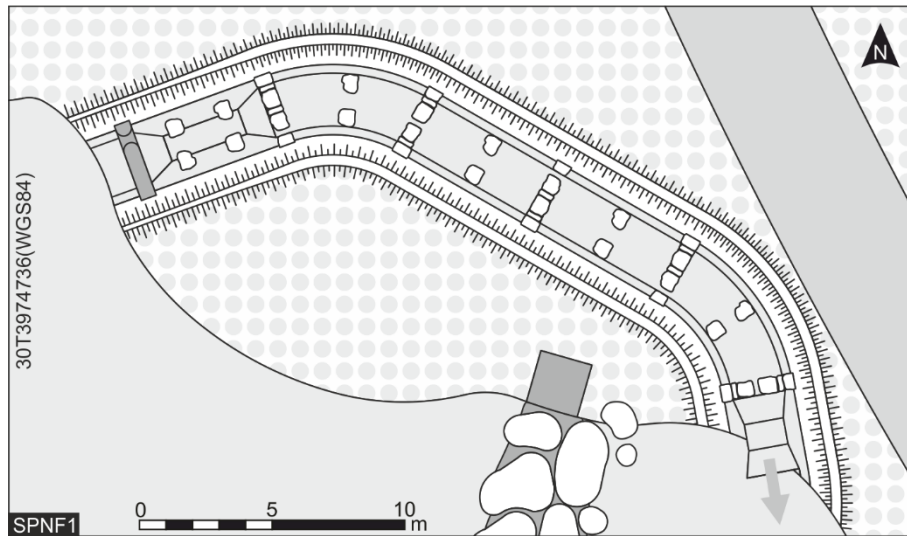

**Figure S2.5.** Step-pool nature-like fishway studied in field. SPNF1: Aguilar de Campoo fish farm fishway.

## Notation

The following symbols are used in S2 Appendix:

$a$  = orifice height (m)

$B$  = pool width (m)

$b$  = notch, slot or orifice width (m)

$e$  = cross-wall thickness (m)

$h_0$  = mean water level of the flow in the pool (m)

$h_1$  = mean water level of the flow in the pool upstream of the cross-wall  
measured from the sill (m)

$h_2$  = mean water level of the flow in the pool downstream of the cross-wall  
measured from the sill (m)

$h_1'$  = mean water level of the flow in the pool upstream of the cross-wall (m)

$h_2'$  = mean water level of the flow in the pool downstream of the cross-wall  
(m)

$L$  = pool length (m)

$p$  = sill height (m)

$Q_{design}$  = theoretical discharge or flow, as calculated in the fishway design project  
(m<sup>3</sup>/s)

$S$  = fishway slope (m/m)

$\Delta H$  = water level difference between pools or head drop ( $\Delta H = h_1 - h_2$ ) (m)

$\Delta Z$  = topographic difference between cross-walls (m)



## **S3 Appendix. Data**

Data available at <https://doi.org/10.1051/kmae/2017013>.

## S4 Appendix. Auxiliary equations

### 1. Dimensional relationships used in vertical slot fishways

(Rajaratnam et al., 1986; Rajaratnam et al., 1992)

$$Q^* = \frac{Q}{\sqrt{g \cdot S \cdot b^5}} \quad (S4.1)$$

$$Q^* = \alpha_0 + \alpha_1 \cdot (h_0/b) \quad (S4.2)$$

Where  $\alpha_0$  and  $\alpha_1$  depend on the geometry of the vertical slot fishway,  $h_0$  is the mean water depth (measured at the center of the pool),  $S$  is the slope,  $b$  is the width of the slot and  $Q^*$  is the dimensionless discharge.

### 2. Discharge coefficient equation used by Krüger *et al.*

(2010)

$$C_s = \beta_0 \left[ 1 - \left( \frac{h_2}{h_1} \right)^{\beta_2} \right]^{\beta_1} \quad (S4.3)$$

where  $\beta_0$ ,  $\beta_1$  and  $\beta_2$  are coefficients which depend on the geometry of the slot or notch, pool dimensions, and the discharge equation used,  $h_2$  is the mean water level of the flow in the pool downstream of the cross-wall deducting the sill height ( $p$ ) and  $h_1$  mean water level of the flow in the pool upstream of the cross-wall deducting  $p$ .

### 3. Dimensional relationships used in pool and weir fishways

(Rajaratnam *et al.*, 1988)

Eq. 4 is proposed for plunging flow regimen and Eq. 5 for streaming flow regimen.

$$Q^* = \frac{Q}{b \cdot \sqrt{g} \cdot h_0^{3/2}} = \frac{2}{3} \cdot \sqrt{2} \cdot C \quad (S4.4)$$

$$Q^* = \frac{Q}{b \cdot h_2^{3/2} \cdot \sqrt{g} \cdot S} = \sqrt{\frac{2}{c_f}} \quad (S4.5)$$

Where  $C$  is a constant discharge coefficient with the value of 0.605 and  $c_f$  is the coefficient of fluid friction.

### 4. Submerged flow in broad-crested weirs (Schröder, 1994)

$$Q = \frac{2}{3} \cdot \sigma \cdot \mu \cdot b \cdot h_1^{1.5} \cdot \sqrt{2 \cdot g} \quad (S4.6)$$

Where  $\mu$  is a constant reduction coefficient that depends on the geometry of the stones (range from 0.5 to 0.8 if sharp-edged or rounded stones respectively (FAO/DVWK, 2002)) and  $\sigma$  is the drowned-flow reduction factor.  $\sigma$  is usually represented graphically by design guidelines (FAO/DVWK, 2002; Larinier *et al.*, 2006). This graphic is based in the relations for submerged flow in broad-crested weirs:

$$\begin{cases} \frac{h_2}{h_1} > x_c & \sigma = \frac{3}{2} \cdot \sqrt{3} \cdot z \cdot \sqrt{1-z} \\ \frac{h_2}{h_1} \leq x_c & \sigma = 1 \end{cases} \quad (S4.7)$$

$$z = \frac{2 - x_c + \frac{h_2}{h_1}}{3 \cdot (1 - x_c)} \quad (\text{S4.8})$$

Where  $x_c$  is an empirical constant defined with a value of 0.614 (Schröder, 1994).

## Notation

The following symbols are used in S4 Appendix:

$b$	=	notch, slot or orifice width (m)
$c_f$	=	dimensionless coefficient of fluid friction
$C$	=	dimensionless coefficient of discharge
$h_0$	=	mean water level of the flow in the pool measured from the sill (m)
$h_1$	=	mean water level of the flow in the pool upstream of the cross-wall measured from the sill (m)
$h_2$	=	mean water level of the flow in the pool upstream of the cross-wall measured from the sill (m)
$p$	=	sill height (m)
$Q$	=	discharge or flow (m <sup>3</sup> /s)
$Q^*$	=	dimensionless discharge
$S$	=	fishway slope (m/m)
$x_c$	=	empirical constant for Eqs. S4.7 and S4.8
$z$	=	auxiliary dimensionless parameter in drowned-flow reduction factor ( $\sigma$ ) equation

$\alpha_0, \alpha_1$  = dimensionless coefficients for Eq. S4.2

$\beta_0, \beta_1, \beta_2$  = dimensionless coefficients for Eq. S4.3

$\sigma$  = drowned-flow reduction factor

$\mu$  = geometry reduction coefficient

## References

FAO/DVWK. 2002. Fish Passes: Design, Dimensions, and Monitoring, FAO, Rome, Italy

Krüger F, Heimerl S, Seidel F, Lehmann B. 2010. Ein Diskussionsbeitrag zur hydraulischen Berechnung von Schlitzpässen. *WasserWirtschaft* 3: 31–36.

Larinier M, Courret D, Gomes P. 2006. Guide technique pour la conception des passes à poissons “naturelles”. Rapport GHAAPPE RA.06.05-V1, Agence de l’Eau Adour Garonne, Compagnie Nationale du Rhône, Conseil Supérieur de la Pêche, Groupe d’Hydraulique Appliquée aux Aménagements Piscicoles et à la Protection de l’Environnement, Institut de mécanique des fluides de Toulouse, 66 p, 66 pp

Rajaratnam N, Katopodis C, Mainali A. 1988. Plunging and streaming flows in pool and weir fishways. *J. Hydraul. Eng.* 114: 939–944.

Rajaratnam N, Katopodis C, Solanki S. 1992. New designs for vertical slot fishways. *Can. J. Civ. Eng.* 19: 402–414.

Rajaratnam N, Van der Vinne G, Katopodis C. 1986. Hydraulics of vertical slot fishways. *J. Hydraul. Eng.* 112: 909–927.

Schröder RCM. 1994. Technische Hydraulik: Kompendium für den Wasserbau, Springer - Verlag Berlin Heidelberg, 308 pp





# **Annex 3. List of articles included in the compilation thesis**







List of articles included in the compilation thesis

(As required by Section 4.1. of the Regulation concerning doctoral thesis defense at Uva)

TO THE CHAIRMAN OF THE PhD BOARD OF THE UNIVERSIDAD DE VALLADOLID

Thesis author: Mr. Juan Francisco Fuentes-Pérez .....

Article 1:

Full publication reference, including all coauthors and date of publication/acceptance Fuentes-Pérez, J.F., Sanz-Ronda, F.J., Martínez de Azagra Paredes, A., García-Vega, A., 2014. Modeling Water-Depth Distribution in Vertical-Slot Fishways under Uniform and Nonuniform Scenarios. Journal of Hydraulic Engineering 140, 6014016. DOI: 10.1061/(ASCE)HY.1943-7900.0000923 .....  
Date of publication: October 2014 Date of acceptance: 29 May 2014 .....  
Indexation database: Thomson Reuters .....  
Impact index 2.183 (JCR Impact factor 2016) .....

Article 2:

Full publication reference, including all coauthors and date of publication/acceptance Fuentes-Pérez, J.F., Sanz-Ronda, F.J., Martínez de Azagra-Paredes, A., García-Vega, A., Martínez de Azagra, A., García-Vega, A., 2016. Non-uniform hydraulic behavior of pool-weir fishways: a tool to optimize its design and performance. Ecological Engineering 86, 5–12. DOI: 10.1016/j.ecoleng.2015.10.021.....  
Date of publication: January 2016 Date of acceptance: 13 October 2015 .....  
Indexation database: Thomson Reuters .....  
Impact index 2.914 (JCR Impact factor 2016) .....

Article 3:

Full publication reference, including all coauthors and date of publication/acceptance Fuentes-Pérez, J.F., A., García-Vega, A., Sanz-Ronda, F.J., Martínez de Azagra Paredes, 2017. Villemonte’s approach: validation of a general method for modeling uniform and non-uniform performance in stepped fishways. Knowledge and management of aquatic ecosystems, 418. DOI: 10.1051/kmae/2017013 .....  
Date of publication: April 2017 Date of acceptance: 28 March 2017 .....  
Indexation database: Thomson Reuters .....  
Impact index 1.131 (JCR Impact factor 2016) .....

NOTES: More than three articles may be included, providing the same information. All publications listed must be accepted or published within the period in which the student has been registered in the PhD program.

IMPORTANT: If articles are accepted but not yet published, a proof must be provided (e.g. a letter from the editor or a screenshot of the article management website).

Place and date: Palencia - 30.06.2017

Signature: .....





# **Annex 4. Declaration of co-authors**





**Universidad de Valladolid**

### CO-AUTHOR PERMISSION

(Art. 8.1.f de la *Normativa para la presentación y defensa de la Tesis Doctoral en la Universidad de Valladolid*)

Mr. Francisco Javier Sanz Ronda with ID nº 15398294-R as co-author of the articles:

1. Fuentes-Pérez, J.F., Sanz-Ronda, F.J., Martínez de Azagra Paredes, A., García-Vega, A., 2014. *Modeling Water-Depth Distribution in Vertical-Slot Fishways under Uniform and Nonuniform Scenarios*. Journal of Hydraulic Engineering 140, 6014016. DOI: 10.1061/(ASCE)HY.1943-7900.0000923
2. Fuentes-Pérez, J.F., Sanz-Ronda, F.J., Martínez de Azagra-Paredes, A., García-Vega, A., Martínez de Azagra, A., García-Vega, A., 2016. *Non-uniform hydraulic behavior of pool-weir fishways: a tool to optimize its design and performance*. Ecological Engineering 86, 5–12. DOI: 10.1016/j.ecoleng.2015.10.021
3. Fuentes-Pérez, J.F., A., García-Vega, A., Sanz-Ronda, F.J., Martínez de Azagra Paredes, 2017. *Villemonte's approach: validation of a general method for modeling uniform and non-uniform performance in stepped fishways*. Knowledge and management of aquatic ecosystems, 418. DOI: 10.1051/kmae/2017013

I give my full consent for their use as part of the PhD Thesis, elaborated as “compendium of publications”, presented at the University of Valladolid by Mr. *Juan Francisco Fuentes Pérez* Entitled *Hydraulic modeling of fishways under variable hydrodynamic scenarios* (in Spanish: *Modelización hidráulica de pasos para peces ante diferentes escenarios hidrodinámicos*).

I report that the contribution of the doctoral candidate has been in all cases as follows: *He defined the research problem, he planned and conducted the experiments, he designed the methodology and algorithms, he analyzed the data and he discussed the results.*

Likewise, I renounce to present them as part of any other PhD thesis as “ordinary modality” or “compendium of publications”.

Palencia, 8<sup>th</sup> June 2017

Fco. Javier Sanz Ronda





**Universidad de Valladolid**

### CO-AUTHOR PERMISSION

(Art. 8.1.f de la *Normativa para la presentación y defensa de la Tesis Doctoral en la Universidad de Valladolid*)

Mr. Andrés Martínez de Azagra Paredes with ID nº 16792147-P as co-author of the articles:

1. Fuentes-Pérez, J.F., Sanz-Ronda, F.J., Martínez de Azagra Paredes, A., García-Vega, A., 2014. *Modeling Water-Depth Distribution in Vertical-Slot Fishways under Uniform and Nonuniform Scenarios*. Journal of Hydraulic Engineering 140, 6014016. DOI: 10.1061/(ASCE)HY.1943-7900.0000923
2. Fuentes-Pérez, J.F., Sanz-Ronda, F.J., Martínez de Azagra-Paredes, A., García-Vega, A., *Martínez de Azagra, A., García-Vega, A., 2016. Non-uniform hydraulic behavior of pool-weir fishways: a tool to optimize its design and performance*. Ecological Engineering 86, 5–12. DOI: 10.1016/j.ecoleng.2015.10.021
3. Fuentes-Pérez, J.F., A., García-Vega, A., Sanz-Ronda, F.J., Martínez de Azagra Paredes, 2017. *Villemonte's approach: validation of a general method for modeling uniform and non-uniform performance in stepped fishways*. Knowledge and management of aquatic ecosystems, 418. DOI: 10.1051/kmae/2017013

I give my full consent for their use as part of the PhD Thesis, elaborated as “compendium of publications”, presented at the University of Valladolid by Mr. *Juan Francisco Fuentes Pérez* entitled *Hydraulic modeling of fishways under variable hydrodynamic scenarios* (in Spanish: *Modelización hidráulica de pasos para peces ante diferentes escenarios hidrodinámicos*).

I report that the contribution of the doctoral candidate has been in all cases as follows: *He defined the research problem, he planned and conducted the experiments, he designed the methodology and algorithms, he analyzed the data and he discussed the results.*

Likewise, I renounce to present them as part of any other PhD thesis as “ordinary modality” or “compendium of publications”.

Palencia, 8<sup>th</sup> June 2017

Andrés Martínez de Azagra Paredes







**Universidad de Valladolid**

### CO-AUTHOR PERMISSION

(Art. 8.1.f de la *Normativa para la presentación y defensa de la Tesis Doctoral en la Universidad de Valladolid*)

Mrs. Ana García Vega with ID nº 71020943-W as co-author of the articles:

1. Fuentes-Pérez, J.F., Sanz-Ronda, F.J., Martínez de Azagra Paredes, A., García-Vega, A., 2014. *Modeling Water-Depth Distribution in Vertical-Slot Fishways under Uniform and Nonuniform Scenarios*. Journal of Hydraulic Engineering 140, 6014016. DOI: 10.1061/(ASCE)HY.1943-7900.0000923
2. Fuentes-Pérez, J.F., Sanz-Ronda, F.J., Martínez de Azagra-Paredes, A., García-Vega, A., Martínez de Azagra, A., García-Vega, A., 2016. *Non-uniform hydraulic behavior of pool-weir fishways: a tool to optimize its design and performance*. Ecological Engineering 86, 5–12. DOI: 10.1016/j.ecoleng.2015.10.021
3. Fuentes-Pérez, J.F., A., García-Vega, A., Sanz-Ronda, F.J., Martínez de Azagra Paredes, 2017. *Villemonte's approach: validation of a general method for modeling uniform and non-uniform performance in stepped fishways*. Knowledge and management of aquatic ecosystems, 418. DOI: 10.1051/kmae/2017013

I give my full consent for their use as part of the PhD Thesis, elaborated as “compendium of publications”, presented at the University of Valladolid by Mr. *Juan Francisco Fuentes Pérez* Entitled *Hydraulic modeling of fishways under variable hydrodynamic scenarios* (in Spanish: *Modelización hidráulica de pasos para peces ante diferentes escenarios hidrodinámicos*).

I report that the contribution of the doctoral candidate has been in all cases as follows: *He defined the research problem, he planned and conducted the experiments, he designed the methodology and algorithms, he analyzed the data and he discussed the results.*

Likewise, I renounce to present them as part of any other PhD thesis as “ordinary modality” or “compendium of publications”.

Palencia, 8<sup>th</sup> June 2017

Ana García Vega





