



Universidad de Valladolid

Escuela Técnica Superior de Ingenieros de Telecomunicación
Dpto. Teoría de la Señal y Comunicaciones e Ingeniería Telemática

TESIS DOCTORAL:

Supporting teacher orchestration of across-spaces learning situations

Presentada por **Juan Alberto Muñoz Cristóbal** para optar al grado de
doctor por la Universidad de Valladolid

Dirigida por:

Juan Ignacio Asensio Pérez
Alejandra Martínez Monés



Universidad de Valladolid

School of Telecommunications Engineering
Dpt. Signal Theory, Telecommunications and Telematics Engineering

DOCTORAL THESIS:

Supporting teacher orchestration of across-spaces learning situations

Presented by **Juan Alberto Muñoz Cristóbal** to qualify for the degree of
doctor of the University of Valladolid

Advisors:

Juan Ignacio Asensio Pérez
Alejandra Martínez Monés

April, 2015

Acknowledgements

Este documento es la consecuencia del trabajo durante varios años de una serie de personas, sin las cuales esta tesis no habría sido posible, y a las que me gustaría agradecer su ayuda.

He tenido mucha suerte de contar con Asen y Alejandra como directores de tesis. Con su capacidad, experiencia y dedicación al trabajo inmensas, han supuesto una guía inmejorable en mi aprendizaje y formación como investigador. Mi más sincero agradecimiento por ser mis guías estos años, marcándome perfectamente por dónde tenía, o no tenía, que caminar. Por identificar cada punto débil en lo que iba(mos) construyendo. Por tener paciencia cuando hacía falta, y por sacar tiempo aun cuando no lo tenían. Gracias también a Yannis por acordarse de mí en 2011, y luego ayudarme e interesarse por mi trabajo de manera continuada durante estos años. Ha sido un lujo poder contar con su visión, y todo su conocimiento y experiencia, y cada una de sus aportaciones, sugerencias o consejos no tiene precio. Me gustaría agradecer también a Iván, mi principal maestro en esto de la investigación cualitativa, todo lo que he podido aprender gracias a él, sobre todo de temas metodológicos, aunque también de educación. Es evidente que su presencia ha cambiado totalmente lo que habría sido la tesis sin ella. Otra persona que ha sido clave en la tesis es Luis Pablo, con su inestimable ayuda, comentarios, revisiones, y pasadas de chapa y pintura en tropecientos papers. Ha sido un placer compartir con él ese final de su tesis y principio de la mía.

Me gustaría agradecer también su ayuda a las personas con las que he podido, por un lado, evaluar las distintas propuestas y “cacharros”, y por otro lado, entender mejor las complejidades de la práctica educativa. A Nesi, compañera de fatigas durante más de un año de recogida de datos (ahí es nada), curranta hasta la extenuación, aportando siempre un punto de diversión. A Quico, por querer participar en este viaje, y por dejarme ser partícipe de esa maravillosa asignatura que imparte y de la que tanto sabe. A Sara, por su ayuda y su predisposición constante a echar una mano. A Borja, que se apuntó a esto de probar lo de la realidad aumentada en el practicum. Por último, agradecer la ayuda y participación de los distintos centros educativos, sus profesores, y estudiantes, en los que se han desarrollado las experiencias que aquí se presentan.

Muchas gracias también a los que han compartido el día a día de un doctorando, y me han echado una mano en múltiples momentos de la tesis, Javi, Rafa, José (Alberto Nistal), Sonia, Henry, Sara (García), Chus, Adolfo, Carlos, Angélica, Mario Marinero, Judith Samaniego, Beatriz Bargiela, Miguel, Edu, Guille, Barto, Osmel, Bea, José Antonio (Marcos), José (Antonio González), Eva, Eloy, David Velasco, Fede, y resto de gente que trabaja o ha trabajado en el grupo de investigación GSIC/EMIC, y que me han aconsejado, ayudado, y acompañado en este tiempo.

Agradecer también su ayuda a los compañeros de los grupos de investigación GTI de la UPF y Gradient de la UC3M, con los que he compartido el proyecto EEE en el que se ha enmarcado principalmente la tesis, Davinia, Mar, Patricia, Javi Melero, Jonathan, Juan Pablo, Josep, Pedro, M^a Carmen, María Blanca, Israel, Derick, Iria, Carlos Delgado, y todos los demás. Y cómo no, a la financiación de los distintos proyectos de investigación que han permitido desarrollar los trabajos que se describen en este documento: 531262-LLP-2012-ES-KA3-KA3MP, TIN2011-28308-C03-02, IPT-430000-2010-054, VA293A11-2, VA277U14, CTEFUva-DIV-2011-02-P3 y CTEFUva-PID-2011-02-P4.

Thanks so much to all who listened to me at any moment of my research process, and gave me any kind of feedback. For sure, their words have had an effect in this dissertation: Armin Weinberger, Pierre Tchounikine, Roberto Martínez-Maldonado, Andreas Papasalouros, Jelena Jovanovic, Giorgos Mitropoulos, Stavros Demetriadis, Anastasios Karakostas, Nikolaos Avouris, Abelardo Pardo, Andreas Harrer, Francesca Pozzi, Jim Slotta and the rest of Encore Lab, Elizabeth Charles, Chris Whittaker and the rest of Saltise, Yishay Mor, Mike Sharples, Katherine Maillet, Gonen Raveh, Marcelo Milrad, Francisco J. García Peñalvo, Miguel Ángel Conde, and many others.

Hasta aquí, todas las personas que he mencionado se han cruzado conmigo a lo largo del trozo de camino en que me he dedicado a la cosa esta de hacer una tesis. Han pasado a formar parte de mi pequeño recorrido en esta aventura que llamamos vida, y en realidad, es lo que al final me llevo, los momentos vividos y compartidos, y lo que más valor tiene para mí.

Pero otras personas llevan recorriendo conmigo este camino desde hace tiempo, a las que he tenido un poco abandonadas durante bastantes momentos estos últimos años. A mis amigos y amigas, de Valladolid, de Montemayor, de Madrid, de teleco. Espero tener un poco más de tiempo a partir de ahora, aunque ya me conocéis, seguro que me meto en otro embolao.

Y a mi familia, especialmente a mi abuela, a Maite, y sobre todo a mis padres y a mi hermana, que siempre han estado ahí, sosteniéndome cuando tropezaba, apoyándome en mis decisiones, las normales, y las raras, y que han tenido que aguantarme muchas veces, en sentido literal y metafórico. Sin ellos, ni esto, ni nada, sería posible.

Valladolid, 29 de Abril de 2015

Abstract

Recent advances in technologies such as mobile devices and Augmented Reality (AR) are helping merge different physical and virtual learning spaces, thus enabling learning situations happening across all of them. How to help teachers achieve such seamless combination of spaces has been marked by the Technology Enhanced Learning (TEL) research community recently as one of the main issues to explore.

The difficulties that teachers face to carry out learning situations in complex authentic educational settings (not only across-spaces) mediated by technology have been addressed in the TEL research field under the umbrella of the “orchestration” metaphor. Different authors have proposed approaches trying to help teachers in different aspects of the orchestration of learning situations that involve multiple physical and virtual spaces. However, such approaches tend to be isolated from the activities and tools already used by teachers, hampering the integration of the proposals in the existing educational practice. This can affect negatively the orchestration load, which some authors call “classroom usability”.

In response to these needs, this thesis aims at supporting teachers in the orchestration of across-spaces learning situations that are not isolated from teachers’ current practice and that can be supported by ICT learning tools already used by those teachers. Following a cyclic research process based on the Systems Development Research Methodology, with an underlying interpretive research perspective, this dissertation identifies two challenges to help teachers in the orchestration of such situations, and contributes with conceptual and technological proposals to overcome such challenges.

The first challenge that teachers face to orchestrate across-spaces learning situations is the implementation of their learning designs in the technological setting in which these designs will be enacted (a process that some authors call deployment). In this dissertation, we focus on three types of spaces: web, physical and 3D Virtual Worlds (3DVWs); and three types of technologies that are currently used in education to access virtual artifacts from such spaces: Virtual Learning Environments (VLEs, e.g., Moodle), mobile AR apps (e.g., Junaio) and Virtual Globes (VGs, e.g., Google Earth), respectively. To this end, we propose the *Point of Interest (POI) model*, which encompasses a basic set of attributes necessary to represent a learning artifact positioned in a space using any of the mentioned technologies. Implementing the POI model, a system can deploy a learning object in multiple VLEs, AR apps and VGs. We have implemented the POI model in *GLUEPS-AR*, a technological proposal that integrates multiple existing learning design authoring tools, VLEs, AR apps, VGs, and artifact providers (e.g., Web 2.0 tools or widgets servers). Using *GLUEPS-AR*, a teacher can deploy a learning design created in any of the authoring tools supported by *GLUEPS-AR* into different Ubiquitous Learning Environments

(ULEs). Such ULEs can be formed by multiple VLEs, AR apps and VGs. Virtual artifacts of any of the artifact providers integrated with GLUEPS-AR can be accessed from any of the spaces (e.g., using VLEs, AR apps or VGs), thus enabling the “flow” of learning artifacts between spaces. GLUEPS-AR includes also features regarding other orchestration aspects, such as the management of the learning situations and the adaptation when facing unexpected events.

The second challenge addressed in this thesis deals with the need to help teachers define a controlled level of flexibility in their designs in order to share the orchestration load with the students. Aiming to aid in this challenge, we propose the *learning bucket* notion: a configurable container of learning artifacts that are created and accessed across-spaces. A learning bucket is created at design time, and configured with constraints to restrict what the students will be able to do with learning artifacts during the enactment (e.g., tools to use, permissions, location, etc.). Such constraints allow the teacher to regulate the degree of freedom/guidance offered to the students. The learning buckets are embedded in activities of the learning situations, and populated during the enactment with artifacts positioned in different spaces. We have implemented the learning bucket notion in the *Bucket-Server* technological proposal. The Bucket-Server is a system that can be integrated with multiple artifact providers (e.g., Web 2.0 tools) in order to include their artifacts in learning buckets. Also, the Bucket-Server offers an Application Programming Interface (API) and can be integrated with multiple third party applications (e.g., VLEs or AR apps) in order to enable them to use buckets.

We have evaluated the proposals by means of multiple feature analyses, pilot studies and evaluation studies, following the Evaluand-oriented Responsive Evaluation Model (EREM). The evaluation results suggest that the proposals help overcome the mentioned challenges, aiding teachers in the orchestration of learning situations that may include multiple technologies and activities of their current practice, and enabling them to introduce, and regulate a degree of freedom offered to the students in the management of learning artifacts during the enactment. However, the evaluation also found shortcomings, which suggest paths for future research, such as solutions to improve the awareness during outdoor activities.

Contents

Acknowledgements	i
Abstract	iii
Contents	v
List of Figures	vii
List of Tables	ix
1 Introduction and summary	1
1.1 Introduction	1
1.2 Research methodology	3
1.3 Dissertation objectives	14
1.4 Main results	15
1.4.1 Contributions	15
1.4.2 Evaluation results	19
1.4.3 Publications	20
1.4.4 Projects	22
1.5 Conclusions	23
1.6 Future work	25
1.7 Structure of the rest of the document	28
2 Deploying learning designs across physical and web spaces: Making pervasive learning affordable for teachers	31
3 Game of Blazons: Helping teachers conduct learning situations that integrate web tools and multiple types of augmented reality	49
4 Learning buckets: Helping teachers introduce flexibility in the management of learning artifacts across spaces	77
5 <i>Bricolaging</i> learning buckets for orchestrating learning across spaces	113
6 Supporting teacher orchestration in Ubiquitous Learning Environments: A study in Primary Education	149
7 Coming down to Earth: Helping teachers use 3D virtual worlds in across-spaces learning situations	167

8 City Ads: Embedding virtual worlds and augmented reality in everyday educational practice	183
References	205
Appendices	215
A Deploying learning designs across physical and web spaces: learning design	217
B APIs, contracts and source code of GLUEPS-AR and Bucket-Server	225
C Evaluation questionnaires	231
Resumen	239

List of Figures

1.1	Life cycle of the Systems Development Research Methodology.	5
1.2	Anticipatory data reduction diagram.	7
1.3	Research process followed in the thesis.	11
1.4	General overview of the context, goal, objectives, contributions and evaluation of the thesis.	17
1.5	Structure of the rest of the document.	29
2.1	Part of the research process covered by Chapter 2.	32
2.2	Contributions and evaluation works covered by Chapter 2.	32
3.1	Part of the research process covered by Chapter 3.	50
3.2	Evaluation works covered by Chapter 3.	50
4.1	Part of the research process covered by Chapter 4.	78
4.2	Contributions and evaluation works covered by Chapter 4.	78
5.1	Part of the research process covered by Chapter 5.	114
5.2	Evaluation works covered by Chapter 5.	114
6.1	Part of the research process covered by Chapter 6.	150
6.2	Evaluation works covered by Chapter 6.	150
7.1	Part of the research process covered by Chapter 7.	168
7.2	Contributions and evaluation works covered by Chapter 7.	168
8.1	Part of the research process covered by Chapter 8.	183
8.2	Evaluation works covered by Chapter 8.	184

List of Tables

1.1	Data gathering techniques.	9
1.2	Research questions (RQs) considered in the different moments of the research process.	12
B.1	Resources of the GLUEPS-AR API inherited from GLUE!-PS, as well as methods and operations allowed	226
B.2	Contract for GLUEPS-AR Learning Environment adapters (inherited from GLUE!-PS).	226
B.3	Contract for GLUEPS-AR Tool adapters (inherited from GLUE!-PS).	226
B.4	Rest of the resources, methods and operations of the GLUEPS-AR API.	227
B.5	Recommended API in GLUEPS-AR Learning Environment adapter (AR-adapter, VLE-adapter, VG-adapter) for being used by Learning Environments.	227
B.6	Bucket-Server API resources, as well as methods and operations allowed.	227
B.7	Contract for Bucket-Server Artifacts Provider adapters.	229
B.8	Recommended API in Bucket-Server Application adapters for being used by applications.	229

Chapter 1

Introduction and summary

This chapter describes the general research context of the dissertation, its goal, the objectives defined and the methodology followed to attain such goal, the main results achieved, the most relevant conclusions, and the structure of the rest of the document. The dissertation deals with the orchestration of across-spaces learning situations (i.e., learning situations that seamlessly integrate activities taking place in multiple physical and virtual spaces). Particularly, we intend to provide conceptual and technological solutions to support teachers in the orchestration of across-spaces learning situations that may include physical, web, and 3D Virtual World spaces. By following the Systems Development Research Methodology with an underlying interpretive perspective, we propose two constructs and two systems to help teachers in the orchestration of across-spaces learning situations. For the evaluation of the proposals, we conducted multiple feature analyses, pilot studies and evaluation studies framed by a responsive evaluation model.

1.1 Introduction

The advance of the technology in the last decades is blurring the boundaries of the traditional education [Cop10], extending the opportunities for learning within and beyond the walls of the classroom [Bru08] [Sha09]. Learning can occur in multiple physical and virtual spaces¹, such as Virtual Learning Environments (VLEs) [Kel05], parks, museums, websites, 3D Virtual Worlds (3DVWs), etc. This extension of learning to other spaces beyond the classroom has been explored by multiple authors under different conceptualizations. *Mobile learning* examines how knowledge is constructed through activity in a society that is increasingly mobile [Sha09]. *Ubiquitous learning* relies on the concept of ubiquitous computing: a vision where computers are embedded in the everyday world [Wei91]. Ubiquitous learning implies a vision of learning which is connected across all the stages on which people play out their life [Bru08]. Ubiquitous learning is referred sometimes as *pervasive learning* [Tho05], due to the usual synonym use of ubiquitous and pervasive computing [Sat01]. The connection of the different contexts² or stages, common

¹We consider a “space” as the dimensional environment in which objects and events occur, and in which they have relative position and direction [Har96]. This definition is not limited to the physical world, also the virtual (computerized) one is considered. Thus, a space would be a container for individuals and their tasks [Cio04], and also for artifacts.

²Most of the authors mentioned in this section differ in the definition of “context”. As an example [Kur08] define context as “the information and content in use to support a specific activity (being individual or collaborative) in a particular physical environment”, and [Sha09] as “an artifact that is continually created by people in interaction with other people, with their surroundings and with everyday tools”.

in both, mobile and ubiquitous learning, is emphasized in *seamless learning*, a term that is being increasingly used the last years [Mil13] [Won11]. Seamless learning is marked by the continuity of the learning experience across different contexts (or environments³). It implies that a student can learn whenever they are curious, in a variety of contexts, and that they can switch from one context to another easily and quickly using the personal device as a mediator [Cha06]. Finally, some authors use the term *across-spaces learning* [DK12], emphasizing the connection of different virtual and physical learning spaces instead of the underlying technology, pedagogy or learning approach.

In all these approaches, technology is an important factor to connect the different contexts, environments or spaces, in order to obtain a single entity where a continuous learning experience is possible. Some authors refer to these entities as *pervasive learning environments* [Syv05] [Tho05], or *Ubiquitous Learning Environments* (ULEs) [Jon04] [Li04]. A learning situation⁴ conducted in a ULE could be named an *across-spaces learning situation*, i.e., a learning situation that seamlessly integrates activities taking place in multiple physical and virtual spaces. Across-spaces learning situations can benefit from the learning affordances of the different spaces involved. Thus, for instance, web spaces (e.g., using VLEs) make students active participants, not just receivers of information, and may foster multiple pedagogical approaches, while enabling both, distance and face-to-face learning [Dil02] [Kel05]. 3DVWs help increase student motivation, enable the perception of objects from multiple perspectives, the simulation of experiences not feasible in the real world, or help in the transfer of knowledge to the real world through the contextualization of learning [Dal10] [Ded09] [Ded96] [Dic03] [War09]. Physical spaces enable contextual learning, the engagement of students in knowledge discovery, and the use of several pedagogical approaches such as placed-based, situated or experiential learning [Dys09] [Klo11]. The seamless combination of the different spaces in a ULE allows also to blur the boundaries between formal and informal learning spheres, and has been marked by the Technology Enhanced Learning (TEL) research community in the last years as one of the key research challenges to explore [Mil13] [Sut12] [Woo10]. Two technologies that are being established as technical solutions to achieve the connection of virtual and physical learning spaces are the mobile devices and Augmented Reality (AR, a technology that combines physical and virtual objects in a physical environment [Azu01]) [Wu13].

In spite of the learning benefits that these across-spaces learning situations may produce, the teachers still have several difficulties for conducting such kind of situations [DK12] [Mil13] [Spi10] [Woo10]. The difficulties that teachers face to carry out learning situations in complex educational settings (not restricted to across-spaces) mediated by technology have been encompassed by the TEL research community under the umbrella of the *orchestration* metaphor [Dil09]. The learning orchestration has been a topic of great interest during the last years (see, e.g., [Bal09] [Ros13]), with different conceptualizations and scopes [Dil10] [Kol13] [Nir10] [Sha13] [Tch13]. Under the umbrella of the orchestration concept, different authors consider aspects such as the design of the learning situations, their management, the adaptation when facing unexpected events, the awareness, the roles of the different actors in the orchestration, the pragmatic constraints, the teachers' theories, or the alignment of the different resources toward the achievement

³A "learning environment" can be defined as "a place where learning is fostered and supported" [Wil95]

⁴We distinguish between "learning situation" and "activity", having the first a higher hierarchical level than the latter. Thus, a learning situation is composed of activities and aims for a global educational objective, which can be achieved through the realization of such activities [BL05].

of the learning goals [Pri11].

Several approaches in the literature have proposed systems that can help teachers in some orchestration aspects when carrying out across-spaces learning situations. Some proposals provide teachers with authoring tools enabling them to create the learning situations (see, e.g., [Klo11] [Mar11] [Mul12] [San11] [Ter12]). Other approaches include awareness functionalities to help in the assessment of students (see, e.g., [Cal09] [Fac04] [PS11] [Zur14]). Others try to help teachers in the management of the learning situation, for example, by automating the creation of tool instances [Liv08] [Pou13]. However, most of the existing approaches propose ad-hoc systems, isolated from the existing tools already in use by teachers and institutions. In addition, most of the systems proposed are designed to support a specific kind of learning situation or activity (e.g., a specific game, or a sequence of geopositioned learning artifacts) not integrated with other activities of the teachers' practice. Moreover, the systems proposing particular authoring tools restrict teachers to the pedagogical and technological possibilities of such authoring tools (the use of these tools would be limited to the teachers and institutions compliant with such possibilities). These limitations may hamper the integration of the proposals with the authentic settings of the teachers' existing practice, which is an important factor to consider in learning orchestration [Cue13] [Pri14b].

In this context, the general problem that is addressed in this thesis is *how technology can help teachers orchestrate across-spaces learning situations that are not isolated from teachers' current practice and that can be supported by ICT learning tools already used by those teachers*. Thus, the goal of the thesis is to answer such research question. We aim to understand the current support provided by technology to teachers for orchestrating their across-spaces learning situations, and contribute with conceptual and technological proposals which help improve the technological support to such situations.

In order to introduce the work carried out in this thesis, the rest of this chapter is structured as follows: the next section describes the research methodology that has been used throughout the research process; Section 1.3 details the main goal of the dissertation, as well as the objectives that have been set towards such goal; Section 1.4 presents the results accomplished in the research process; Section 1.5 contains the main conclusions obtained and Section 1.6 the future works that can emerge from the thesis; finally Section 1.7 summarizes the structure and contents of the rest of the dissertation.

1.2 Research methodology

When I started this thesis, my background in engineering and science constrained me to an understanding of the world where the laws that control the phenomena are objective and independent of such phenomena and the researcher. Thus, the empirical physical and social world would exist independently of humans, and its nature could be characterized and measured. The phenomena could be fragmented, described by means of a formal language, and their laws would exist *a-priori*. So, as independent and objective observers, we the researchers, with our also independent and objective instruments, measurements and experiments, could understand such laws ("discover" them), and describe, even predict, the behavior of the phenomena, generalizing it independently of the time and the context. Those were my assumptions about the world and the

knowledge. In other words, those were my ontological and epistemological beliefs. Doing this thesis, I learned that such assumptions correspond to a specific research approach or research philosophy, named positivism⁵ [Coh07] [Cre09] [Gub94] [Orl91], which has been the dominant research approach in Information System (IS) research recently [Orl91] and in the physical and social sciences for some 400 years [Gub94]. When I started to research in the TEL domain, I found a multidisciplinary field, where engineers, computers scientists, pedagogues, educators or psychologists coexist, work together, and research from a variety of perspectives. Some of such perspectives are based on other research approaches common in social sciences, and very different (if not diametrically opposed) to positivism, such as the interpretive, pragmatic and critic research approaches [Coh07] [Cre09] [Gub94] [Orl91]. In fact, when I started to research in the domain, I realized that some of the assumptions of positivism did not match well with my research line, related to humans, organizations of humans, and proposing systems to help humans. I considered problematic to assume the objectivity and the independence of the researcher and the phenomenon explored. For instance, since one of the aims of the thesis is to contribute with technological proposals (i.e., systems), how could I understand and evaluate the effect of such systems without interacting or interfering with the phenomenon (e.g., by means of introducing a system in educational contexts)? Those problems of the positivist approach to research in social contexts [Orl91] led me to change my understanding of what is research, and to learn that there are different accepted research paradigms with different views of the world (ontology) and the knowledge (epistemology). Finally, the research approach followed in this thesis is interpretive, since I consider it matches well with the phenomenon investigated (the orchestration problem for teachers in across-spaces learning situations) and its context (persons and organizations of persons).

As a consequence, the ontological and epistemological assumptions, or beliefs, of such research approach and therefore, of this thesis, are different from the ones of positivism [Coh07] [Gub94] [Orl91]: in the interpretive paradigm, there is not an objective given reality, independent of humans, but there are multiple realities [Coh07] [Gub94], which are subjective social products, constructed by humans through their action and interaction [Gub94] [Orl91], and they cannot be understood independent of the social actors [Orl91]. Social systems, such as organizations or groups, do not exist apart from humans, and cannot be characterized and measured in some objective and universal law. The reality cannot be discovered, but interpreted, by the in-depth examination of and exposure to the phenomenon of interest. Thus, the researcher cannot be neutral, objective, or independent of the phenomena, and is always implicated in the phenomena studied [Orl91]. This interpretive perspective and their assumptions shape the works carried out during this thesis, and needs to be comprehended (even disagreeing with them) to understand the research process and methodology described throughout the dissertation.

This thesis is framed in a doctoral program on information and telecommunication technologies and aims to contribute to the field by proposing ICT-based solutions. Therefore, we explored different research methodologies common in the TEL and IS fields. Some of the approaches explored were the engineering method sketched by [Adr93], the computing research phases stated by [Gla95], the approaches to software engineering outlined by [Mor95], Software Engineering Research Methodology [Gre01], Systems Development Research Methodology [Nun90], Mixed Methods [Cre09], Design Science [Hev04] [Pef07], Design Based Research [Wan05], Action research [Avi99] and Case Study research [Sta95] [Yin81].

⁵For the sake of clarity, we include as “positivism” the different positivist and post-positivist approaches.

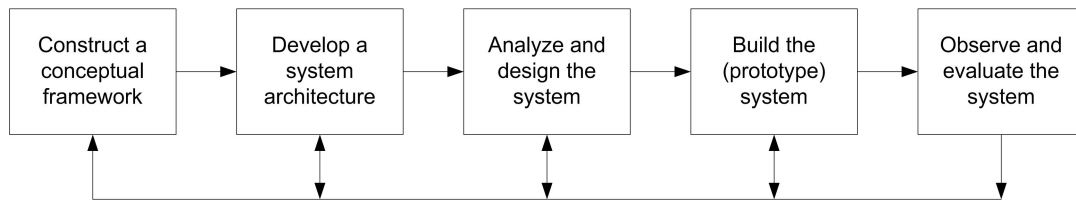

Figure 1.1: Life cycle of the Systems Development Research Methodology [Nun90].

Finally, we selected the Systems Development Research Methodology [Nun90] as the one to follow during the thesis. The main reasons of this decision were the following.

- It is a recognized IS research methodology that combines aspects of the usual social and engineering research processes. Therefore, it matches well with the aforementioned assumptions and research approach of the thesis, as well as with its ICT engineering perspective.
- It has an evolutionary nature. Thus, experiences and knowledge gained can help refine the system, but also lead to new research questions and proposals. This is coherent with our underlying interpretive perspective.
- It is an appropriate methodology for researches in which the creation of systems is central to the research process, and in this thesis, the systems proposed and the evaluation of their orchestration support for teachers play a central role.

Such methodology defines a research process life cycle consisting of the following five phases [Nun90] (see Figure 1.1).

1. **Construct a conceptual framework.** This phase would involve the identification of a research problem, and the definition of the research questions. The research problem should be new, creative, and important in the field. Also, the significance of the research questions should be justified. Such research questions should be discussed in the context of an appropriate conceptual framework. This conceptual framework leads to theory building, which may be of different types, such as declaration of “truth”, formulation of concepts (frameworks), construction of methods, or development of theories. This phase also involves the proposal of a solution of the research problem. Such proposal could require the development of a system to demonstrate the validity of the solution.
2. **Develop a system architecture.** This phase involves the statement of the objectives of the development effort and the definition of the requirements and functionalities of the resulting system to achieve the stated objectives. These requirements should be defined so that they can be validated at the evaluation stage. This phase also implies the definition of the architecture of the resulting system, which provides a road map of the system building process. The architecture puts the system components into perspective, specifies the system functionalities, and defines the structural relationships and dynamic interactions among system components.

3. **Analyze and design the system.** This phase involves everything related to the design of the system and the design decisions: the understanding of the studied domain, the application of relevant scientific and technical knowledge, the proposal and exploration of various alternatives, the final design decisions, and the specification of the system (e.g., data structures, data bases, knowledge bases, program modules and functions, etc.). These design specifications should be used as a reference guide in the implementation of the system.
4. **Build the system.** This phase consists in the implementation (built) of the system. Often, the researches conduct their research by building a prototype. In order to enable the testing of the system in a real world setting, an effort to further develop the prototype into a working system, usable in the target domain is necessary. The process of implementing the working system can provide researches with insights into the advantages and disadvantages of the concepts, the frameworks, and the chosen design alternatives. The accumulated experience and knowledge help redesign the system, e.g., in subsequent cycles of the research process.
5. **Experiment, observe, and evaluate the system.** This phase involves the evaluation of the system, based on the conceptual framework and the requirements of the system defined at the earlier stages. Different types of evaluation can be conducted, such as experiments, or observations of the impact of the system in individuals, groups or organizations (e.g., by means of surveys, case studies, action research, etc.). Development is an evolutionary process. The knowledge acquired from developing the system usually leads to further development of the system, or even the discovery of a new theory to explain newly observed phenomena.

These phases are coherent with other typical frameworks and methodologies of engineering and IS research, consisting basically in iterations or cycles of: study of the state of the art, identification of a research problem, proposal of a contribution (in which the creation of a system is crucial), system design + prototyping, and evaluation (e.g., [Adr93] [Gla95] [Mor95] [Pef07]). It is interesting to briefly discuss the particular case of the Design Science approaches [Hev04] [Pef07]. The Systems Development Research Methodology followed in this thesis can be, in fact, considered as one of the Design Science precursors (see [Hev04]), and it is one of the approaches in which the Design Science Research Methodology is based on (see [Pef07]). However, the Design Science Research Methodology divides the research process in six phases (instead of the five of the Systems Development Research Methodology, see Figure 1.1), and the iterations are performed only between the last five phases, excluding the first phase (*definition of the problem*) from the iterations [Pef07]. We consider that this exclusion makes the iterations focus on refining the solution (e.g., artifacts, foundations or methodologies), and hampers an evolutionary perspective in which the research process could also lead to new research questions and proposals or to their refinement. The same view is also perceived in the more general approach of Design Science stated by [Hev04]. Therefore, we understand that the Systems Development Research Methodology fits better with our underlying interpretive perspective.

In the last phase of the Systems Development Research Methodology life cycle, the evaluation, we followed the Evaluand-oriented Responsive Evaluation Model (EREM) [JA09]. The

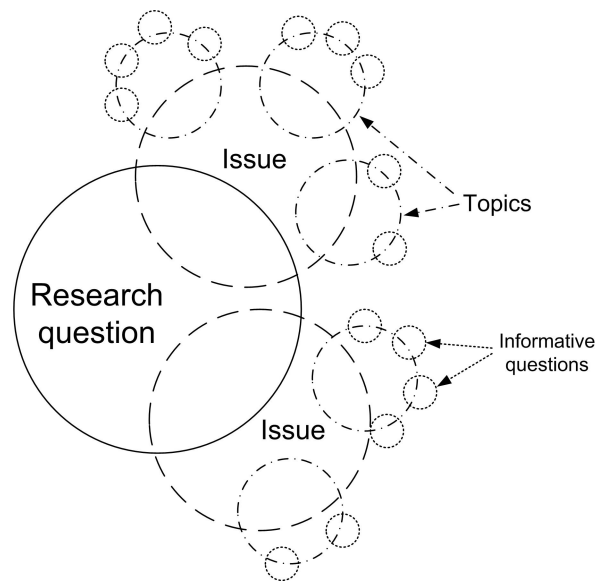

Figure 1.2: Anticipatory data reduction diagram.

EREM is a framework conceived as an evaluation model for a wide range of ubiquitous collaborative learning settings. It provides clear and understandable guidance to researchers involved in the evaluation of innovations in this kind of settings. By proposing a particular organization of the complexity of the field, it is especially useful for those researchers that are novice in evaluation. The EREM strengthens the idea of conducting evaluations centered in the phenomena to be evaluated (*evaluand*) rather than in the field of expertise of the evaluators (e.g., human computer interaction, didactics, etc.). The model is framed within a responsive evaluation approach [Sta04], promoting responsiveness to key issues and problems recognized by participants at the site and stakeholders elsewhere. This evaluation method follows an interpretive research perspective [Coh07] [Gub94] [Mil94] [Orl91] that does not pursue statistically significant results or generalizations. Rather, it aims at a deeper understanding of the concrete phenomena under study [Gub81].

We chose to use the EREM model because it is an evaluation instrument that matches well with the underlying interpretive research perspective of the thesis as well as with the phenomena and context investigated: orchestration of across-spaces learning settings. Moreover, we considered it very appropriate due to the guidance and help that the framework provides to novel evaluators, as is the case in this thesis. Examples are the different conceptual tools provided by the EREM, such as an evaluation design diagram, or a multimedia collaborative report. These conceptual tools are supported with corresponding software tools⁶ that facilitate to plan and conduct an evaluation. A final reason to decide to use the EREM as an evaluation framework in the thesis was that it had been used successfully in multiple PhD theses in the research group wherein this thesis was carried out, GSIC/EMIC (see, e.g., [AH12] [Mar12] [Pri12] [RT14] [RC13]). So, there was experience in its use in such team, which could help and support the evaluation process.

In order to carry out each evaluation, we formed an evaluation team, composed of different

⁶<http://pandora.tel.uva.es/csc1-erem/>. Last access April 2015.

researchers of the GSIC/EMIC research group. During the evaluation design, we conducted an anticipatory data reduction process [Mil94] to explore the research question, creating a schema of “research question – issue – topics – informative questions” (see Figure 1.2). Thus, we defined issues as the main conceptual organizers of the evaluation process. Such issues were divided into more concrete topics to help us understand the different dimensions within the issues. In the same fashion, each topic was explored through various informative questions. The schema “research question – issue – topics – informative questions” also guided the data collection during the evaluation processes, which were carried out using a profuse set of data sources and informants. Table 1.1 describes the different data gathering techniques employed throughout the thesis and their purpose in the evaluation. As it is usual in the aforementioned underlying interpretive philosophy, the data gathering processes relied highly on a qualitative approach [Coh07]. Thus, the quantitative techniques used in the thesis were mostly reduced to measuring time and counting the number of learning artifacts created by the participants. Since we used multiple data gathering techniques (including as mentioned before a reduced number of quantitative ones) and evaluation methods (i.e., feature analyses, pilot studies and evaluation studies), we consider that we have followed a mixed methods approach [Cre09], and we use such terminology during part of the evaluation works. While we were advancing in the thesis and gaining insight into the research problem, our interpretive perspective increased, and we emphasized the qualitative nature of the research.

For the data analysis, the anticipatory data reduction schema was used as an initial category tree for the process of coding, therefore using a dominantly deductive *a-priori* approach for the creation of an initial set of codes [Cre09] [Mil94] [Pop00]. Regarding the process of coding, different approaches of qualitative research have different considerations about how the analysis should be performed (e.g., some approaches do not use coding) [Coh07] [Mil94]. In our case, the coding of the qualitative data gathered during the evaluation works was made mainly by a single member of the research team (the author of this document). We recognize that using more coders would increase the credibility of the research. However, we consider a single-coder sufficient, given the interpretive nature of the study, the dominantly deductive approach (with a predetermined and agreed initial category tree), and the fact that we do not aim to measure, quantify, obtain statistical significant results or find relations between variables, but rather make sense of the participants perceptions and experiences [Cre09]. The main instruments for the data analysis were text documents, spreadsheets, and the NVivo⁸ software. Finally, the evaluation team interpreted the data and identified the findings.

A critical concern in a research process is how to assure its quality and rigor. Since interpretive research assumes the complexity and uniqueness of the cases/situations/phenomena under study, and does not aim to generalize, the quality of the research cannot be assessed in terms of how the cases/situations/phenomena are controllable, replicable or generalizable [Coh07] [Gub81]. Instead of these goals, interpretive research aims to a deep understanding of phenomena [Coh07] [Gub81] [Mil94], and therefore, it is usual in this perspective to use very small and purposive samples of people, nested in their authentic contexts, and study them in depth [Mil94]. Hence, in interpretive research, the notions of reliability, internal/external validity and objectivity used in positivist approaches to assure the quality of a research are replaced with the notions of dependability, credibility, transferability and confirmability [Coh07] [Gub81] [Kra09]

⁷General templates of the questionnaires used during the evaluation are included in Appendix C

⁸<http://www.qsrinternational.com/products.aspx>. Last access April 2015.

Table 1.1: Data gathering techniques.

Technique	Description	Purpose
Collection of participant-generated artifacts	Collection of a diverse set of electronic artifacts generated by the participants, and digitalization (e.g., pictures) of non-electronic ones. Types of data collected include emails with teachers, learning designs, materials and products, VLE courses, students' notebooks, teachers' reflections, assessment reports from schools' teachers.	Registering the learning design process, as well as the use of the systems and tools by the participants. Being aware of the participants' asynchronous activities. Gathering the opinions of the participants. Complementing the observations with information of the learning artifacts generated.
Time measurement	Time measurements of different processes carried out by the participants.	Measuring the amount of time that these processes require.
Screen recording	Recording, using specialized software, of the actions conducted in the computer by the participants during different evaluation events.	Understanding the design and deployment processes, and measuring the amount of time that these processes require.
Observation	Naturalistic, semi-structured observations during different evaluation events. The observations were conducted by different researchers. The data collected were chat messages, audio/video recordings, pictures and observation notes.	Registering the actions, impressions and other emergent issues of the participants during different evaluation events.
Questionnaire ⁷	Web-based exploratory questionnaire, designed in an iterative review process by different evaluators and external researchers. Composed of open-ended and closed items (6-point scale [1=strongly disagree, 2=disagree, 3=somewhat disagree, 4=somewhat agree, 5=agree, 6=strongly agree] + Don't know/No answer). Qualitative score sheets for the scoring of the support provided by systems to a set of features.	Getting the opinions of participants over a wide range of matters.
Interview	Semi-structured, face-to-face, one-to-one conversation with the participants (recorded and transcribed).	Capturing the opinions of the participants in depth, after an initial analysis of other data sources (e.g., observation data, questionnaire answers, etc.).

[Mil94] [She04]. The strategies to comply with these criteria from an interpretive perspective are very different from the ones used to ensure quality in a positivist research, and include (among others) long permanence in the field, use of multiple data gathering techniques, use of deep descriptions, member checking, etc. [Coh07] [Gub81] [Kra09] [Mil94] [She04]. We used several of these strategies, namely: prolonged engagement during months of work with the different teachers and persistent observation in the field; member checking, obtaining feedback from the informants about the data and the interpretations; acknowledgement of participant opinions, by interviewing the teachers and by analyzing teachers' and students' reflections; integration of the thorough collaborative observation reports in a single portfolio, thus enabling a thick description of the phenomenon under scrutiny, reported in detail to the whole evaluation team; peer review within the evaluation team to avoid bias; exploration of the systems in different educational contexts; triangulation of data sources, methods and researchers to cross-check data and interpretations. The triangulation of researchers was conducted by involving in the evaluation team experienced researchers usually with distinct perspectives (i.e., with pedagogical or technological background). Such researchers participated conducting independent observations, which were compiled and discussed in joint collaborative multimedia reports. The triangulation

of methods involved the usage of several data gathering techniques (questionnaire, interview, etc.) and evaluation methods (feature analyses, pilot studies, studies). The triangulation of data sources was carried out employing multiple data sources and informants, ensuring that each finding was corroborated by multiple pieces of evidence of different types. We have also adopted a descriptive style to report the research and its results, with a detailed account of the context, participants and learning situation, as well as of the evaluation design and its implementation, including the data gathering techniques employed. We tried to illustrate the process carried out with different tables, figures, and excerpts of every kind of evidence. We have followed a common approach to present interpretive results, consisting in a textual narrative describing the findings and results, which includes data supporting them in the form of quotes [Ber89] [Kna84] [Kra09] [Lic10] [Mer02] [Mil94]. Such detailed account is another strategy typically employed in interpretive research to achieve credibility and transferability [Gub81] [Lin09].

Figure 1.3 shows the research process followed in the thesis. As the figure illustrates, it is composed of three cycles of the Systems Development Research Methodology process. The sequence of cycles was not completely linear in time, since we had to adapt to the temporal requirements of the participants in the different evaluation works. Thus, we started a new cycle when we already had the necessary information to do it, even though some evaluation studies of the previous cycle were not finished and they overlapped with the beginning of the new cycle. Table 1.2 shows the research questions considered in different moments of the research process. In each cycle, we posed initial research questions, which guided us to the formulation of proposals and the creation of systems. During the evaluation phase, we posed new research questions (usually dividing the initial research question into more specific sub-questions), which helped us evaluate the system. As the Table 1.2 illustrates, there are some differences between the wordings of the different research questions, especially those corresponding to the evaluation (at the end of each cycle). This is caused because the research process in a thesis is long (it takes years) and usually non-linear, evolving from its beginning to its end. This evolution, in our case, was affected by both my evolution in my training as a researcher, and the evolution of our understanding of the domain and the phenomenon under study. In addition, since the present dissertation is a compendium of articles, some research questions changed during the publication processes. Table 1.2 identifies the different research questions with labels, which are also used in Figure 1.3 to indicate the different moments when they were formulated. The next paragraphs summarize the research process followed throughout the three cycles of the Systems Development Research Methodology.

- **Cycle 1.** In the first phase of the first cycle, field observations conducted in research works related to learning orchestration previous to the thesis [MC12b] [Pri13a] [Pri14a], together with a literature review of learning orchestration as well as across-spaces, mobile and ubiquitous learning, led to the definition of the research problem that guided the research throughout the thesis: the teacher orchestration of across-spaces learning situations. In the first cycle, we focused on a research question regarding the creation, deployment and enactment⁹ of across-spaces learning situations in web and physical spaces. We aimed to overcome the limitations of the existing approaches in the field for the deployment and integration of the different activities performed and tools used, while fitting with the teachers'

⁹We mean with “deployment” the implementation of a conceptual learning design in the technological setting in which it will be conducted. We mean with “enactment” the act of conducting such learning design (e.g., with students).

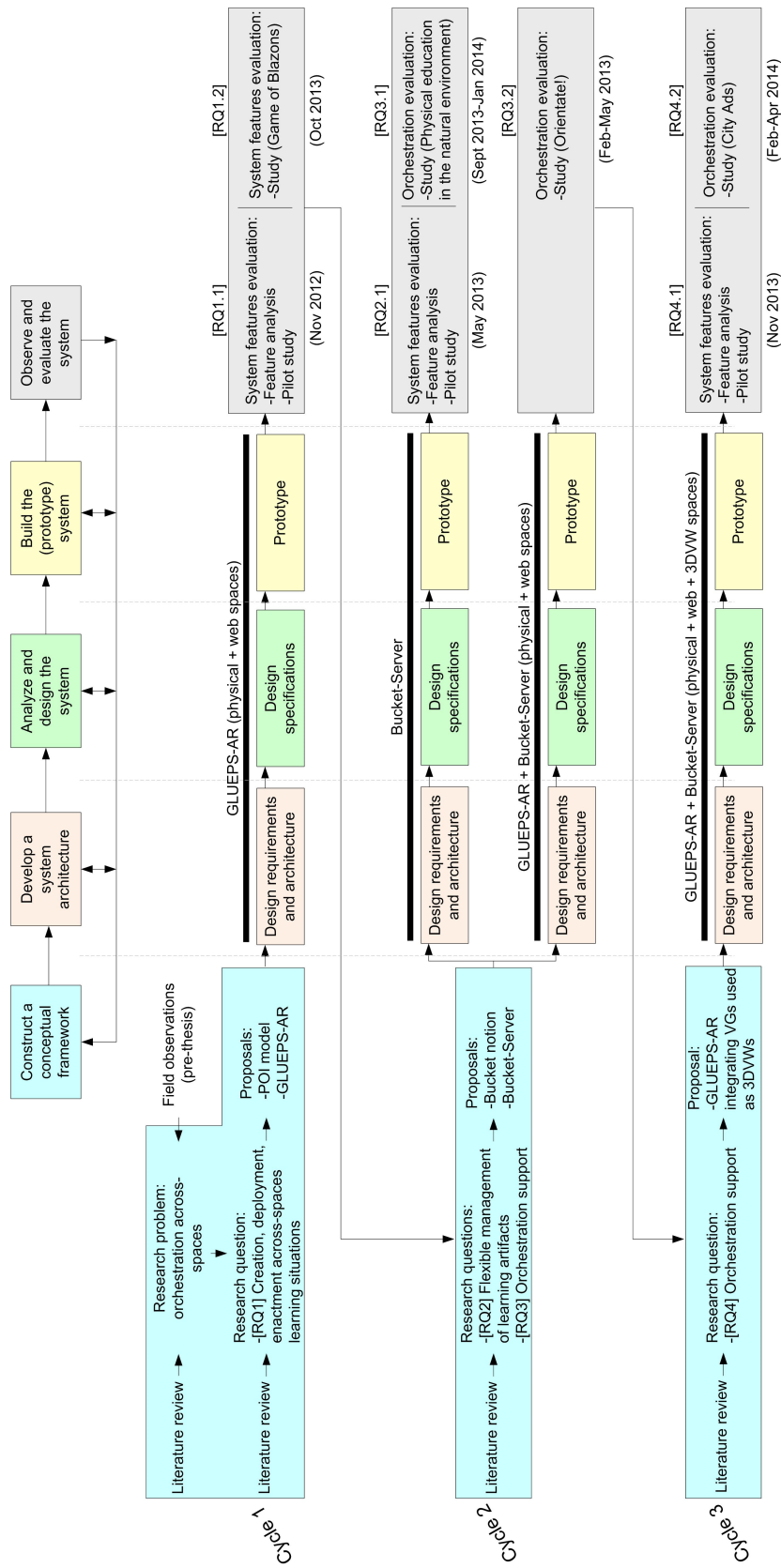

Figure 1.3: Research process followed in the thesis.

Table 1.2: Research questions (RQs) considered in the different moments of the research process.

Cycle	RQs at the beginning of the cycle	RQs at the end of the cycle
Cycle 1	[RQ1] How can technology help teachers affordably create, deploy and enact across-spaces learning situations that may involve web and physical spaces, are not isolated from teachers' current practice, and can be supported by ICT learning tools already used by those teachers?	[RQ1.1] Does GLUEPS-AR make the deployment of authentic pervasive learning situations affordable for teachers, overcoming the limitations of the existing approaches? [RQ1.2] How can technology help teachers affordably create and enact authentic learning activities that may use different types of AR, different kinds of augmented spaces, and combine AR with other technologies commonly used by teachers?
Cycle 2	[RQ2] How can technology help introduce flexibility in the management of learning artifacts during the enactment of across-spaces learning situations, guided by the teachers' pedagogical decisions, and in a way that is integrated with current practice? [RQ3] How can technology help teachers orchestrate across-spaces learning situations that may involve web and physical spaces, are not isolated from teachers' current practice, and can be supported by ICT learning tools already used by those teachers?	[RQ2.1] How can technology help introduce flexibility in the management of learning artifacts during the enactment of across-spaces learning situations, guided by the teachers' pedagogical decisions, and in a way that is integrated with current practice? [RQ3.1] How do the learning buckets help teachers orchestrate their learning situations conducted across different physical and virtual spaces? [RQ3.2] How does GLUEPS-AR help teachers orchestrate their across-spaces learning situations conducted in ULEs?
Cycle 3	[RQ4] How can technology help teachers orchestrate across-spaces learning situations that may involve web, physical and 3DVW spaces, are not isolated from teachers' current practice, and can be supported by ICT learning tools already used by those teachers?	[RQ4.1] Does GLUEPS-AR enable teachers to deploy their across-spaces learning situations including web spaces, AR-enabled physical spaces, and VGs (used like 3DVWs)? [RQ4.2] How does GLUEPS-AR help teachers appropriate immersive environments such as 3DVWs and mobile AR in their current educational practice and technological ecology of the classroom with an affordable orchestration effort?

existing practice (see Table 1.2). This first cycle resulted in two contributions: a construct, consisting in a model for learning artifacts positionable in a physical space (*Point of Interest, POI, model*), and a system using such model, aimed to help teachers create, deploy and enact across-spaces learning situations (*GLUEPS-AR*). Guided by the identified limitations of the existing approaches, we defined the GLUEPS-AR design requirements, its architecture (phase 2), the design specifications (phase 3), and we built a prototype (phase 4). We followed an iterative and incremental model in the software development processes, which we considered coherent with the underlying research methodology. In this first cycle, although it is not represented in Figure 1.3 for the sake of clarity, we performed an iteration creating a first limited prototype as a proof of concept [MC12a], before the development of the system that we evaluated in this first cycle. Such evaluation (phase 5) followed the EREM framework, and relied on a feature analysis, a pilot study and a study, in which the research question posed in the phase 1 was particularized in two research questions focused on GLUEPS-AR (see Table 1.2). The main works carried out in the first cycle are included in Chapters 2 and 3.

- **Cycle 2.** The results of the first cycle helped us identify minor improvements necessary in the system to eventually provide support for the multiple aspects of the orchestration of

across-spaces learning situations, as well as a major limitation in our approach that affected some of these aspects. Such limitation regarded the introduction of flexibility, guided by the teachers' pedagogical decisions, in the management of learning artifacts during the enactment of across-spaces learning situations (e.g., allowing the students to choose, under the control of the teacher, the tools to use, or where to create/access learning artifacts). Thus, in the first phase of the second cycle, we conducted a new literature review, focused in the aforementioned flexibility, and we posed a new research question regarding how technology could help in this flexibility, apart from the main research question of the overall thesis, the support provided by the proposals to the multiple aspects of orchestration, which was also explored in this second cycle (see Table 1.2). As a solution for the problem of the flexible management of learning artifacts in the enactment of across-spaces learning situations, we proposed the *learning bucket* notion (a configurable container of positionable learning artifacts) as well as the *Bucket-Server*, a system implementing the bucket notion to help teachers in such flexibility. In this second cycle, we created the Bucket-Server system (phases 2-4), and evaluated its use independently of GLUEPS-AR (phase 5). We also integrated the Bucket-Server with GLUEPS-AR (phases 2-4) and evaluated the orchestration support provided by the resulting system (phase 5). As in the cycle 1, the research questions formulated in the phase 1 of this cycle were particularized in the evaluation in new research questions focusing on the proposals (see Table 1.2) and we followed the EREM framework for conducting the evaluation. Chapters 4, 5 and 6 describe the main research works carried out in cycle 2.

- **Cycle 3.** In addition to refining the systems with minor improvements (e.g., regarding the user interface), in the first phase of the third cycle we wondered if our approach could be easily extended to support teachers in the orchestration of learning situations involving other kinds of spaces besides the physical and web ones. We focused on another virtual space intensively explored in the education domain during years: 3DVWs. After a literature review of the use of 3DVWs in education, and specifically, in across-spaces learning situations, we posed the research question of how can technology help teachers orchestrate across-spaces learning situations that may involve web, physical and 3DVW spaces, integrate the different activities performed and tools used, and fit with the teachers' existing practice. During the previous cycles, we had detected a GLUEPS-AR limitation for the awareness in physical spaces, and we had carried out some proofs of concept with students' avatars in mobile AR browsers during the first cycle (see Chapter 3) and VGs during the second one. These tests, together with the literature review, led us to propose to extend the GLUEPS-AR system to enable the integration of Virtual Globes (VGs, 3D virtual representations of the surface of the Earth, such as Google Earth¹⁰) [Rak08] used as 3DVWs in the across-spaces learning situations supported by GLUEPS-AR. We defined the design requirements and architecture (phase 2), design specifications (phase 3) and we built the system creating a new version of GLUEPS-AR (phase 4). In this cycle we tested the system in different load tests and implemented enhancements in the efficiency, before the final evaluation. Afterwards (phase 5), we conducted an evaluation in which, as in the rest of cycles, we followed the EREM framework and the research question of the phase 1 was particularized to focus on the system developed (the new version of GLUEPS-AR and its integration with the Bucket-Server) (see Table 1.2). The main works carried out in the third cycle are

¹⁰<https://www.google.com/earth/>. Last access April 2015.

included in Chapters 7 and 8.

It is important to notice the evolutionary perspective of the methodological process followed: we consider that the experience, understanding and knowledge gained from the whole process of development in each cycle, including the observation of, and interaction with the phenomena investigated, was a key factor, together with the literature reviews, for the identification of research questions and the generation of proposals in the subsequent cycle. This combination of the deductive and inductive approaches followed tries to be coherent with the interpretive perspective of the research, while at the same time follows a typical engineering / IS research process. This way we have tried to agree upon two perspectives (the interpretive paradigm when researching phenomena related to humans, and the engineering / IS research methodologies when proposing ICT-based solutions) that initially, when we started the research, seemed to be so different and irreconcilable.

We conducted cycles until reaching three different educational contexts, that we considered reasonable to make compatible the viability in time of the thesis with the transferability and credibility of the results. Thus, finally we performed: three features analysis and pilot studies (one per cycle) as well as one study, for the evaluation of the systems' features; and three studies for the evaluation of the support provided to orchestration. Four teachers were involved in the different evaluation works, with different teaching expertise (from months to 23 years), lecturing in two different educational levels (Primary education, university), in three different subjects (physical education, physical education in the natural environment, ICT on education), and with different technological background (all of them non-ICT experts except for one advanced ICT user). Also a different number of students (18, 30 and 64) were involved in the studies. In addition, we received feedback from 7 lectures/researchers experts in the field of across-spaces learning. We expect that the different teachers and contexts involved increase the possibilities of making the knowledge acquired during the research process transferable to other research works. We recognize that more participant teachers would increase the credibility and transferability of the results. Nevertheless, we consider that the four teachers involved in the evaluation are sufficient, due to the interpretive perspective of the research, and to the fact that we do not aim to generalize or obtain statistically significant results, but rather to the in-depth study of the use of the proposals by the involved teachers. Figure 1.4 shows the detail of the different profiles and the evaluation studies in which the different teachers participated.

1.3 Dissertation objectives

As mentioned in Section 1.1, the general goal of the thesis is to answer the research question: *how can technology help teachers orchestrate across-spaces learning situations that are not isolated from teachers' current practice and that can be supported by ICT learning tools already used by those teachers?* In order to achieve such general goal, we have defined two dissertation objectives¹¹, which were specified during the research process described in Section 1.2.

¹¹We consider dissertation objectives the research objectives defined and addresses during the whole research process that is presented in this dissertation, and not the initial objectives posed at the beginning of the research process.

1. **To support teachers in the affordable deployment of across-spaces learning situations. Such learning situations should be able to include web, physical and 3DVW spaces, support ICT learning tools already used by those teachers, and not be isolated from teachers' current practice.**

There are different approaches proposing technological solutions for helping teachers deploy their learning designs in a space (e.g., web, physical or 3DVW), and for helping teachers deploy their designs in different spaces. However, such proposals tend to restrict teachers to use specific technologies, typically different to those that they already use (e.g., proposing new VLEs, AR apps or 3DVWs). This can isolate the activities supported by such approaches from other activities conducted by the teachers who use them. Therefore, there is a necessity of alternative solutions which may extend the range of activities and tools of those of the existing approaches, enabling teachers the affordable deployment of across-spaces learning situations that may be embedded in their current practice.

2. **To support teachers in the flexible management of learning artifacts generated by teachers and students during the enactment of across-spaces learning situations, guided by the teachers' pedagogical decisions. Such learning situations should also be able to include web, physical and 3DVW spaces, support ICT learning tools already used by those teachers, and not be isolated from teachers' current practice.**

There are some proposals that enable the carrying out of across-spaces learning situations with a certain flexibility in the management of learning artifacts during the enactment (for instance, allowing the students to choose the tools to use, see, e.g., [Con14] [DJ10] [Mik13]). Such flexibility can contribute to some student-centered approaches, and to share the orchestration load with the students, which can be an important factor in ubiquitous environments [Sha13]. However, such proposals tend to prevent teachers from regulating the degree of flexibility offered to students, and are typically disconnected from the teachers current practice. Therefore, new solutions are needed to allow teachers to introduce a controlled balance between guidance and freedom in the students' management of learning artifacts during the enactment of across-spaces learning situations. Also, such new solutions should support learning situations more embedded in the teachers everyday practice than those situations supported by the existing approaches.

1.4 Main results

This section summarizes the main contributions and the evaluation results obtained during the research process. This section also mentions the different publications accepted until the moment of the presentation of the dissertation, and the research projects related to the works described in this dissertation.

1.4.1 Contributions

Figure 1.4 shows a diagram with an outline of the thesis context, objectives, contributions and evaluation. The main contributions are two constructs (*POI model* and *learning bucket* notion)

and two systems (*GLUEPS-AR* and *Bucket-Server*) which implement the constructs. The main advances in the conceptual and technological proposals occurred in each of the three cycles of the research process.

- **POI model.** As explained in Section 1.1, there is a limitation in the existing proposals to support across-spaces learning situations able to make use of different existing technologies that the teachers may choose to use in their practice. These technologies include, for instance, multiple web VLEs, mobile AR clients or 3DVWs. A major issue for achieving the integration of such technologies into the across-spaces learning situations supported is that each system uses a different data model to represent an object positioned in a space. As a solution for this challenge, and part of the objective 1 of the thesis (to support teachers in the affordable deployment of across-spaces learning situations), we proposed the *Point of Interest (POI) model*. It represents a learning artifact that can be positioned in a space, using a model compatible with multiple existing specifications, data models and systems aimed to position objects in a space. For proposing the model, we combined bottom-up and top-down analyses, reviewing both, existing software applications that position objects in a space, and specifications and models in the literature to represent objects in a space. We did it in two phases (in different cycles of the research process), a first phase focusing on physical spaces and AR applications (see Chapter 2), and a second one confirming the validity of the model to be extended to a different space by studying VGs data models (see Chapter 7). For proposing the model, we selected a reduced set of attributes from the multiple ones that the different specifications and applications implement, based on our purpose of representing learning artifacts. The resulting POI model enables the representation of a learning artifact positioned in a space, using multiple data models, specifications and software applications. So, it is a key factor for enabling the “flow” of the learning artifact from one application to another, and therefore, from one space to another (across-spaces).
- **Learning bucket notion.** As part of the objective 2 of the thesis (to support teachers in the flexible management of learning artifacts generated by teachers and students during the enactment of across-spaces learning situations, guided by the teachers’ pedagogical decisions), *learning buckets* aim to enable teachers to introduce a certain and controlled flexibility in the management of learning artifacts during the enactment of across-spaces learning situations. A learning bucket is a configurable container of learning artifacts that are created/accessed across-spaces. A bucket can be embedded in learning environments in different spaces (e.g., in a web VLE, an AR mobile client used in a physical space, etc.). Learning buckets are created by teachers in the learning design phase, included in activities of a learning situation, and configured with constraints, i.e., the limitations to define what students will be able to do in the bucket during the enactment (e.g., tools to use, allowed positioning types, etc.). A bucket can be empty when is created, and it is filled with learning artifacts by the students during the enactment from the learning environment where it is embedded. Such artifacts can be created using multiple widespread tools, and can be positioned in different spaces using a number of positioning types (e.g., using geographical coordinates, AR markers, QR codes, etc.). Chapters 4 and 5 deal in detail with the learning bucket notion.
- **GLUEPS-AR.** Aligned with the objective 1 of the thesis (to support teachers in the affordable deployment of across-spaces learning situations), *GLUEPS-AR* is a system that

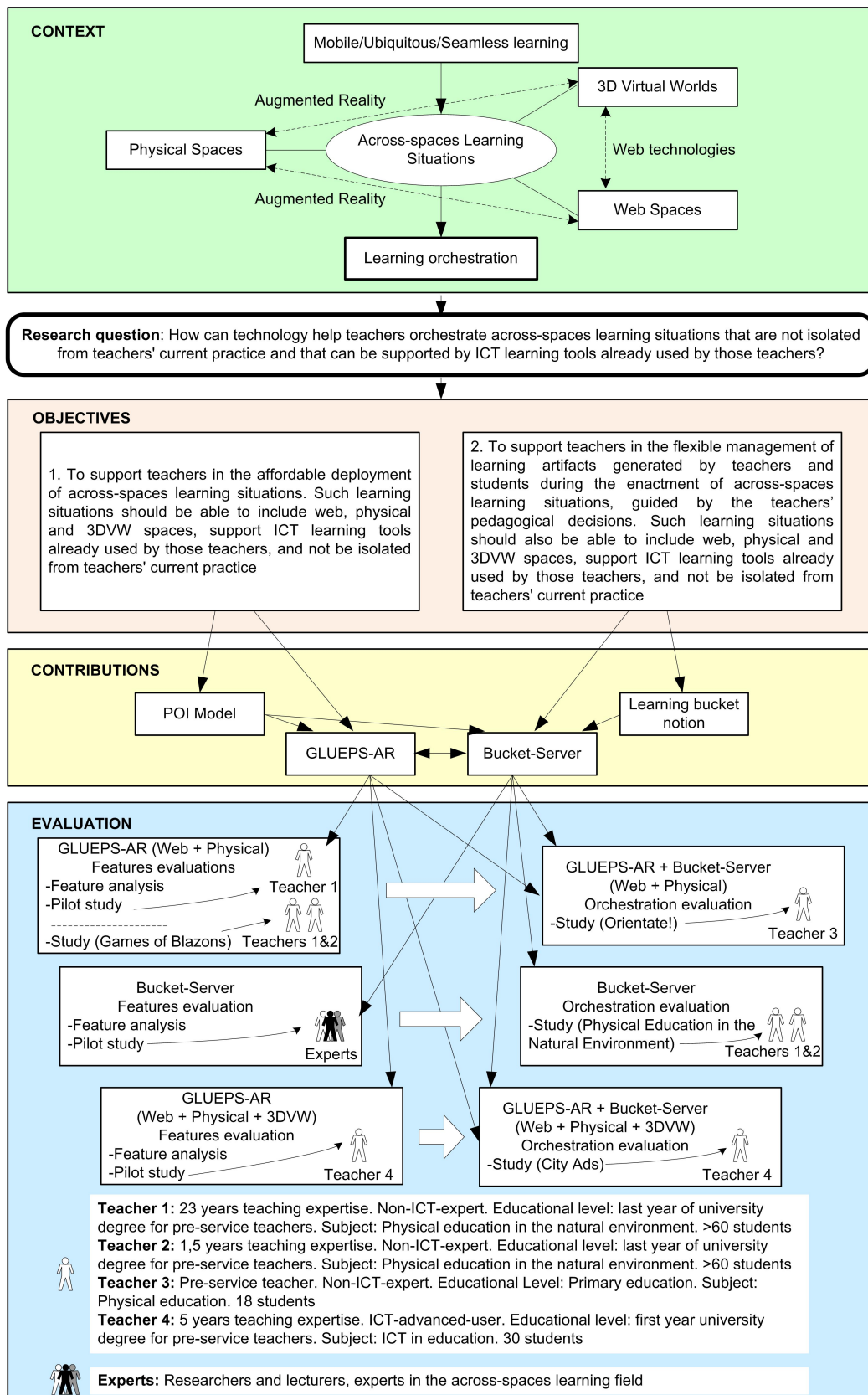

Figure 1.4: General overview of the context, goal, objectives, contributions and evaluation of the thesis.

implements the POI model. It is aimed to support multiple aspects of the orchestration of across-spaces learning situations. One of the purposes of GLUEPS-AR is to enable teachers to deploy their learning designs into the technological settings in which they will enact the learning situations. Learning design [Kop05] is an approach that aims to allow teachers make explicit their pedagogical ideas by using standard languages interpretable by computers, in order to enable them to share and reuse the designs. GLUEPS-AR extends the architecture of its predecessor system, GLUEPS [Pri13a], which enabled the deployment of learning designs, which could have been created in different authoring tools, into multiple web-based distributed learning environments. Thus, GLUEPS-AR, broadening the scope to environments including different physical and virtual spaces, enables teachers to deploy their learning designs in ULEs. Furthermore, GLUEPS-AR sets up these ULEs, by integrating learning environments in different spaces (e.g., using web VLEs, Web 2.0 tools, mobile AR clients and VGs used as 3DVWs). In addition, GLUEPS-AR enables teachers to choose among multiple existing systems for the creation of the ULE. In such ULE, GLUEPS-AR allows the flow of learning artifacts between the different spaces, for instance, a Google Docs¹² document could be accessed from a VLE in a first activity, with a mobile AR client in a specific physical position in a subsequent activity, and simultaneously from a VG used as a 3DVW and the web VLE in a final activity. Thus, GLUEPS-AR enables the integration of the different activities carried out across spaces. GLUEPS-AR also supports other multiple orchestration aspects, e.g., acting as a control panel that helps teachers manage and be aware of the learning situation. Following the cyclic research process, we developed two versions of GLUEPS-AR: the first version supporting ULEs involving web and physical spaces (first cycle), and the second one supporting ULEs involving also 3DVWs (third cycle). The research works related to GLUEPS-AR are presented in Chapters 2, 3, 6, 7 and 8.

- **Bucket-Server.** Aligned with the objective 2 of the thesis (to support teachers in the flexible management of learning artifacts generated by teachers and students during the enactment of across-spaces learning situations, guided by the teachers' pedagogical decisions), the *Bucket-Server* is a system that implements both the POI model and the learning bucket notion. The Bucket-Server aims to help teachers in the flexible management of learning artifacts during the enactment of across-spaces learning situations, thus sharing the orchestration load between teachers and students. The Bucket-Server enables teachers to create buckets, to configure them with constraints restricting what is possible to do in them, and enables students to manage their artifacts, which can be positioned in different spaces with a number of positioning types. Thus, the students, under the constraints defined by the teacher, can take decisions (among others) about the tools to use and the position of artifacts to create/access. The Bucket-Server provides an Application Programming Interface (API) to be used by different software applications in different spaces. The Bucket-Server technological proposal was mainly explored in the second cycle of the research process. We have created a prototype of the Bucket-Server (see Chapter 4), and evaluated its use: (1) with a direct integration with web VLEs and mobile AR clients and therefore, enabling teachers to create buckets, e.g., directly from a VLE and accessing the buckets' artifacts from the VLE and from mobile AR clients (see Chapter 5); and (2) with its integration with GLUEPS-AR, and therefore, enabling teachers to create

¹²<http://www.google.com/docs/about/>. Last access April 2015

their designs in multiple learning design authoring tools, to include and configure learning buckets in activities of such design, and to deploy them in ULEs composed of web VLEs, mobile AR clients and VGs used as 3DVWs (see Chapters 6 and 8). The integration of the Bucket-Server with GLUEPS-AR adds flexibility in the management of learning artifacts during the enactment to GLUEPS-AR, allowing the teacher to regulate such flexibility. This flexibility improves the support provided by GLUEPS-AR to the orchestration by enabling to share the orchestration load between teachers and students, and by allowing the teacher to control the degree of freedom offered.

1.4.2 Evaluation results

Several evaluation works were carried out during the different cycles of the research process (see Figure 1.3 and Figure 1.4).

- During the **first cycle**, the evidence showed that GLUEPS-AR supported an affordable deployment and enactment of across-spaces learning situations, overcoming the main identified limitations of the existing approaches for deploying such kind of situations. Thus, GLUEPS showed able to integrate multiple technologies and embed AR in the participant teachers' existing practice; it supported flows of learning artifacts across web and augmented physical spaces (using multiple types of AR); and it supported deploying multiple kinds of learning activities. During the evaluation we also detected an important limitation of GLUEPS-AR in the (lack of) flexibility offered to students during the enactment, inherited from the GLUEPS-AR's learning design foundations, which were very teacher-centered. It could affect negatively to the orchestration of learning situations requiring more student-centered activities. Also, we detected some limitations in the GLUEPS-AR user interface (addressed in subsequent cycles), mainly regarding the time that repetitive operations required from teachers.
- The **second cycle** centered on the limitation of flexibility detected in the previous cycle in the students' management of learning artifacts, as well as on the support provided by GLUEPS-AR in the multiple aspects of orchestration. During the evaluation, learning buckets and the Bucket-Server showed evidence of being a useful tool for providing flexibility in the management of learning artifacts during the enactment of across-spaces learning situations. The Bucket-Server showed also evidence of overcoming the challenges for a flexible management of learning artifacts in across-spaces learning situations posed by the existing solutions providing flexibility during the enactment. Thus, the Bucket-Server was integrated with multiple systems used commonly in the learning domain, helping teachers in the management of such resources, while enabling teachers to control the degree of flexibility offered to students. In addition, the Bucket-Server showed helpful to enable the participant teachers to create, using a web VLE not initially conceived for across-spaces learning (e.g., Moodle¹³), learning situations that involved multiple physical and virtual spaces. In this cycle we evaluated the support provided to the teacher orchestration by both, the Bucket-Server, and the integration of GLUEPS-AR with the Bucket-Server. The evidence gathered pointed to both systems supporting multiple orchestration aspects in

¹³<https://moodle.org/>. Last access April 2015.

ULEs involving web and physical spaces. The combination of GLUEPS-AR and Bucket-Server showed more appropriate for the orchestration of complex learning situations (e.g., requiring non-trivial collaborative learning), although they also showed to be rather time-demanding regarding the design and deployment of such situations. On the other hand, the Bucket-Server showed to be a useful tool for the orchestration of less complex learning situations, like those that can be easily created from a VLE such as Moodle, and not so much for more complex learning situations (e.g., with non-trivial collaborative learning), which would demand a lot of work to designers using the Bucket-Server. Both systems showed a limited support for the awareness orchestration aspect, especially in activities in physical spaces.

- The **third cycle** centered on a new version of GLUEPS-AR including also VGs, and user awareness by means of avatars in both, VGs and mobile AR clients. Evaluation evidence showed that the creation of across-spaces learning situations involving a VLE, mobile AR clients and VGs used as 3DVWs was affordable for the involved teacher. Thus, GLUEPS-AR enabled the deployment of learning situations in ULEs which may include the three type of spaces (web, physical, 3DVW), choosing among multiple technologies in each type of space (VLEs, Web 2.0 tools, mobile AR clients, VGs), and enabling the access to virtual learning resources from the three spaces. Furthermore, GLUEPS-AR enabled user awareness in physical spaces and 3DVWs by means of avatars. In addition, the evaluation evidence showed that GLUEPS-AR used jointly with the Bucket-Server helped the teacher appropriate ULEs including immersive environments such as AR and 3DVWs in her everyday practice, as well as aided the teacher in the multiple aspects of orchestration. One of such aspects was the sharing of the orchestration load with the students, by enabling teachers, with the use of learning buckets, to introduce (and regulate) flexibility in the students' management of learning artifacts during the enactment.

1.4.3 Publications

The following documents describing the works and results of the thesis are published or accepted for publication at the time of presenting the dissertation (all of them in peer-reviewed publications). The list only includes those publications in which the dissertation's author is first author.

- Publications in JCR-indexed international journals:
 - (J1) Muñoz Cristóbal, J.A., Prieto Santos, L.P., Asensio Pérez, J.I., Martínez Monés, A., Jorrín Abellán, I.M., Dimitriadis, Y. Deploying learning designs across physical and web spaces: Making pervasive learning affordable for teachers *Pervasive and Mobile Computing*. 14:31-46, 2014.
 - (J2) Muñoz Cristóbal, J.A., Martínez Monés, A., Asensio Pérez, J.I., Villagrà Sobrino, S.L., Hoyos Torío, J.E., Dimitriadis, Y. City Ads: Embedding Virtual Worlds and Augmented Reality in Everyday Educational Practice *Journal of Universal Computer Science*. 20(12):1670-1689, 2014.

- (J3) Muñoz Cristóbal, J.A., Jorrín Abellán, I.M., Asensio Pérez, J.I., Martínez Monés, A., Prieto Santos, L.P., Dimitriadis, Y. Supporting Teacher Orchestration in Ubiquitous Learning Environments: A Study in Primary Education *IEEE Transactions on Learning Technologies*. 8(1):83-97, 2015.
- (J4) Muñoz Cristóbal, J.A., Prieto Santos, L.P., Asensio Pérez, J.I., Martínez Monés, A., Jorrín Abellán, I.M., Dimitriadis, Y. Coming down to Earth: Helping teachers use 3D virtual worlds in across-spaces learning situations *Educational Technology & Society*. 18(1):13-26, 2015.
- Publications in non-JCR-indexed international journals:

(J5) Muñoz Cristóbal, J.A., Prieto Santos, L.P., Asensio Pérez, J.I., Jorrín Abellán, I.M., Dimitriadis, Y. Orchestrating TEL situations across spaces using Augmented Reality through GLUE!-PS AR *Bulletin of the Technical Committee on Learning Technology*. 14(4):14-16, October 2012.
 - Publications in international Conference Proceedings:

(C1) Muñoz-Cristóbal, J.A., Asensio-Pérez, J.I., Prieto-Santos, L.P., Jorrín-Abellán, I.M., Dimitriadis, Y., Martínez-Monés, A. Helping educators to deploy CSCL scripts into mainstream VLEs that integrate third-party Web and Augmented Reality Tools *Proceedings of the Workshop on Digital Ecosystems for Collaborative Learning. International Conference of the Learning Sciences, ICLS 2012, Sydney, Australia, July 2012*.

(C2) Muñoz-Cristóbal, J.A., Prieto-Santos, L.P., Asensio-Pérez, J.I., Jorrín-Abellán, I.M., Dimitriadis, Y. Lost in Translation from Abstract Learning Design to ICT Implementation: a Study Using Moodle for CSCL *Proceedings of the 7th European Conference on Technology Enhanced Learning, EC-TEL 2012, Saarbrücken, Germany, September 2012*.

(C3) Muñoz-Cristóbal, J.A., Prieto-Santos, L.P., Asensio-Pérez, J.I., Jorrín-Abellán, I.M., Martínez-Monés, A., Dimitriadis, Y. GLUEPS-AR: A System for the Orchestration of Learning Situations Across Spaces Using Augmented Reality *Proceedings of the 8th European Conference on Technology Enhanced Learning, EC-TEL 2013, Paphos, Cyprus, September 2013*.

(C4) Muñoz-Cristóbal, J.A., Prieto-Santos, L.P., Asensio-Pérez, J.I., Jorrín-Abellán, I.M., Martínez-Monés, A., Dimitriadis, Y. Sharing the Burden: Introducing Student-Centered Orchestration in Across-Spaces Learning Situations *Proceedings of the 8th European Conference on Technology Enhanced Learning, EC-TEL 2013, Paphos, Cyprus, September 2013*.

(C5) Muñoz-Cristóbal, J.A. Helping educators to orchestrate learning situations involving multiple physical and virtual spaces *Proceedings of the Doctoral Consortium at the 8th European Conference on Technology Enhanced Learning, EC-TEL 2013 - DC, Paphos, Cyprus, September 2013*.

(C6) Muñoz-Cristóbal, J.A., Asensio-Pérez, J.I., Martínez-Monés, A., Dimitriadis, Y. Orchestrating learning across spaces: Integrating heterogeneous technologies of the existing educational practice *Proceedings of the Orchestrated Collaborative Classroom*

Workshop. 11th International Conference on Computer Supported Collaborative Learning, CSCL 2015, Gothenburg, Sweden, June 2015.

- (C7) Muñoz-Cristóbal, J.A., Asensio-Pérez, J.I., Martínez-Monés, A., Prieto-Santos, L.P., Jorrín-Abellán, I.M., Dimitriadis, Y. Bucket-Server: A system for including teacher-controlled flexibility in the management of learning artifacts in across-spaces learning situations *Proceedings of the 10th European Conference on Technology Enhanced Learning*, EC-TEL 2015, Toledo, Spain, September 2015. Accepted for publication.

- Publications in Spanish Conference Proceedings:

- (C8) Muñoz-Cristóbal, J.A., Prieto-Santos, L.P., Asensio-Pérez, J.I., Martínez-Monés, A., Jorrín-Abellán, I.M., Dimitriadis, Y. Augmented Reality in Education *Proceedings of the XXI University Conference on Educational Technology*, JUTE 2013, Valladolid, Spain, June 2013.

1.4.4 Projects

Part of the works performed in the thesis shape the majority of the research work carried out to accomplish the fulfillments of the following project:

- “EEE-WEB: Orchestrating educational web and mirrored spaces”. Date: 2012-2014. Funding entity: Spanish Ministry of Science and Innovation (TIN2011-28308-C03-02). Participant entities: University of Valladolid. Principal Investigator: Yannis Dimitriadis. Amount awarded: 160.930€

In addition, part of the works performed in the thesis generated the proposals and shape the majority of the research work of the following awarded (in competitive basis) local and regional projects:

- “AR-ML: State of the art of the Augmented Reality, applied to the use of mobile devices in education (m-learning)”. Date: 2012. Funding entity: Partnership in Mobility and Education of Telefónica and the University of Valladolid (CTEFUva-DIV-2011-02-P3). Participant entities: Telefónica, University of Valladolid. Principal Investigator: Yannis Dimitriadis. Amount awarded: 3000€
- “AR4AII: Supporting teachers in the educative use of the Augmented Reality with mobile devices”. Date: 2012. Funding entity: Partnership in Mobility and Education of Telefónica and the University of Valladolid (CTEFUva-DIV-2011-02-P4). Participant entities: Telefónica, University of Valladolid. Principal Investigator: Juan I. Asensio-Pérez. Amount awarded: 6000€
- “Support to teachers in the automatic deployment, flexible enactment and evaluation of ubiquitous learning situations that make a joint use of existing Virtual Learning Environments, Augmented Reality applications and 3D Virtual Worlds”. Date: 2014-2016. Funding entity: Regional Government of Castilla y León (VA277U14). Participant entities: University of Valladolid. Principal Investigator: Yannis Dimitriadis. Amount awarded: 28.999€

1.5 Conclusions

As indicated in Section 1.3, the general goal of this thesis was to answer the research question: *how technology can help teachers orchestrate across-spaces learning situations that are not isolated from teachers' current practice and that can be supported by ICT learning tools already used by those teachers?* In order to reach such goal, we defined two objectives, emphasizing some of the current challenges for helping teachers in the orchestration of across-spaces learning situations:

- (1) **To support teachers in the affordable deployment of across-spaces learning situations. Such learning situations should be able to include web, physical and 3DVW spaces, support ICT learning tools already used by those teachers, and not be isolated from teachers' current practice.** In order to fulfill this objective, we proposed the POI model and the GLUEPS-AR system. By means of such proposals, teachers can deploy learning designs (that may have been defined in different authoring tools) in multiple ULEs. Such ULEs can be formed by a set of web VLEs, mobile AR clients and VGs, thus enabling teachers to choose among a variety of common technologies that may fit with their current practice. Also, multiple existing virtual artifacts (such as those of the Web 2.0) can be accessed from the multiple spaces, achieving a “flow” of learning artifacts between spaces that help connect the different activities carried out. The multiple evaluations conducted suggest that GLUEPS-AR enables an affordable deployment of across-spaces learning situations, as well as helps teachers in the multiple aspects of orchestration.
- (2) **To support teachers in the flexible management of learning artifacts generated by teachers and students during the enactment of across-spaces learning situations, guided by the teachers' pedagogical decisions. Such learning situations should also be able to include web, physical and 3DVW spaces, support ICT learning tools already used by those teachers, and not be isolated from teachers' current practice.** In order to fulfill this objective, we proposed the learning bucket notion and the Bucket-Server system. Using these proposals, teachers can introduce learning buckets in their activities, and configure them with constraints to control the degree of flexibility offered to the students in the management of learning artifacts. During the enactment, the students can populate the buckets with learning artifacts of multiple types (e.g., those of the Web 2.0), which can be positioned in different spaces. Such learning buckets enable the students to take technological (e.g., tools to use), contextual (e.g., position of artifacts) and arbitrary (e.g., number of artifacts) decisions, which are controlled by the teacher's constraints. We have evaluated the learning bucket by integrating the Bucket-Server with GLUEPS-AR, and alternatively directly with web VLEs and AR apps. Evaluation evidence shows that the Bucket-Server (and therefore, the learning buckets) enabled teachers to introduce a controlled flexibility in the management of learning artifacts during the enactment of across-spaces learning situations embedded in the teachers' current practice, and helped teachers in multiple aspects of orchestration.

The fulfillment of the two objectives of the thesis leads us to assert that this dissertation has achieved its goal of answering the research question posed. Thus, this dissertation shows how by means of constructs such as the POI model and the learning bucket notion, and systems

such as GLUEPS-AR and the Bucket-Server, teachers can be helped to orchestrate across-spaces learning situations embedded in their current practice, supporting ICT tools that the teachers were already using. Nevertheless, we can also reflect on a number of lessons that we have learned throughout the thesis.

GLUEPS-AR is a general-purpose alternative to other proposals in literature which aim to help teachers in the orchestration of across-spaces learning situations with a more specific scope (e.g., focusing on creating games, in a sequence of geopositioned artifacts, or in particular spaces or tools). Even if such alternatives could adapt better to specific situations or pedagogies, GLUEPS-AR aims to be usable in a wider scope, enabling teachers to choose between multiple types of tools focused on different spaces, and therefore helping them embed ULEs in their everyday practice. We expect that integrating tools that many teachers already use in the education domain may promote the adoption of technologies and environments that have shown learning benefits, but are not extendedly used by teachers and institutions. That can be the case of immersive environments such as AR or 3DVWs. In the evaluation works, we have seen how teachers that probably would not have used immersive technologies such as AR or 3DVWs, finally embedded them in their everyday practice. Evaluation evidence suggests that using existing systems, such as common mobile AR clients or VGs used as 3DVWs, and achieving their seamless integration with other existing educational technologies favored the adoption of the immersive technologies. On the other hand, the possibility of using such new environments opens new possibilities (and challenges) for the teachers, who demand training and reflection to be able to take advantage of the full potential of the proposed ULEs. In our research, the participant teachers did not alter severely their usual pedagogical scenarios, and they used GLUEPS-AR and the Bucket-Server to enrich such scenarios and connect the different physical and virtual spaces. However, these systems opened them to new didactic possibilities which, as reported by the teachers themselves, would require some effort to understand and study.

During the field work, we have seen that ULEs are highly prone to unexpected events and technology faults. Thus, the capability of the orchestration system to adapt the design when facing unexpected events is critical in this type of environments. Moreover, we consider that teachers should always anticipate faults, preparing a backup plan to be used in the case of a technological breakdown. The necessity and existence of a backup plan was something that recurrently appeared during the thesis, even when in our case the technology worked reasonably well during the whole process (with the exception of some scenarios in mountainous areas with bad internet connection, see Chapter 5), and the systems proposed showed a good capability of adapting to expected and unexpected events.

It is interesting to notice that an orchestration system such as GLUEPS-AR is able to transform a set of independent spaces into a unique ULE with seamless transitions between the spaces. Furthermore, an orchestration system such as the Bucket-Server is able to even convert a web learning environment which does not support natively across-spaces learning (e.g., Moodle or a wiki-based VLE) in an across-spaces system where teachers and students can create across-spaces activities, and use them across the web VLE and other spaces, such an AR-enabled physical one.

The learning buckets played an important role, since we saw that the sharing of the orchestration load can be critical in ULEs. In such environments, where learning activities may occur in multiple spaces and usually requiring the use of multiple tools, the teacher may be overwhelmed

by the effort required to coordinate the learning situation. In such cases, a certain capability for students' self-regulation can be a must. On the other hand, during the evaluation we observed that the inclusion of systems for allowing such sharing of the orchestration load also increases initially the load for teachers. This is caused mainly because teachers have to train students in the use of such tools. This additional load has to be considered since it could prevent the use of the orchestration systems in situations in which teachers are already overwhelmed and without enough time available.

The proposal of the learning buckets highlights the benefits of the interpretive perspective of the research process followed. The learning bucket notion emerged as a necessity that was consequence of a limitation in the GLUEPS-AR support to orchestration detected in the first cycle of the research process. Initially it was envisioned as an internal functionality of GLUEPS-AR, but was finally implemented as an external tool prioritizing a more flexible usage over a better integration with GLUEPS-AR. During the field work, evaluation evidence showed that the Bucket-Server could be a good orchestration solution, simpler than GLUEPS-AR, for the case of some teacher profiles. This emergence of a solution to respond to the participants needs exemplifies the interpretive perspective of the research and the responsive nature of the evaluation. Thus, for instance, in the case of teachers' profiles not requiring complex learning designs (e.g., not using complicated collaborative configurations), with a high degree of improvisation (i.e., not interested in reusing their learning designs), and designing their situations shortly before their enactment (and thus, demanding very fast implementations), the evaluation showed that a solution like the Bucket-Server could fit better than others like GLUEPS-AR (based on a learning design approach, probably counter-productive in this case). Thus, it opened a line of research, parallel to the main one, which we followed in the second cycle of the research process (see Figure 1.3). The results were very interesting, since we understood that different teacher profiles could require different orchestration solutions, and we were able to detect it, and to provide two alternatives, each one with their own advantages and disadvantages.

Throughout this dissertation, we describe in detail several scenarios and evaluation studies. We expect that such detailed depiction provides a degree of transference that enables other researches to take advantage of them. We consider innovative the different scenarios presented, and they may illustrate the different challenges addressed in this thesis for the teacher orchestration of across-spaces learning situations. Also, the evaluations carried out could guide other researchers to conduct similar evaluations of other ubiquitous orchestration systems.

Finally, the publications related to the contents of this dissertation, including four papers in international JCR-indexed peer-reviewed journals, one in an international peer-reviewed journal, and several in national and international conferences (see Section 1.4.3) can be considered as first indicators of the relevance and originality of our proposals, and they also support the importance of the possible future work, which is described in the next section.

1.6 Future work

Besides the aforementioned lessons learned during the research process of this thesis, several issues and opportunities emerged that suggest future research lines. The most significant ones are presented below.

- **Across-spaces.** The research carried out illustrates the complex ecology of technological and social resources that shapes ULEs. During the research we detected that there is not a clear taxonomy of the different elements involved in a ULE (it is illustrated by the different definitions of context mentioned in Section 1.1). Future work could drive to a categorization of the different technological, social and conceptual elements involved in ULEs. Such categorization could benefit incomers in the field, since it is not easy to understand the nuances that differentiate concepts, and the roles that the different resources play in a ULE.
- **Orchestration.** The evaluation of the contributions of this thesis has shown the need of gaining further insight into the awareness aspect in across spaces learning situations. Further research is necessary to explore the awareness requirements of teachers in the different spaces and integrate effective monitoring features useful for the teachers in future proposals. These monitoring features should consider the teachers' restricted time during the enactment of across-spaces learning situations. Also, we used the *5+3 aspects* orchestration framework [Pri11] as a research instrument, which showed to be very useful to validate orchestration from a wide perspective. However, our work has also shown that it needs further refinement, since in some cases we found difficulties in mapping a finding with an orchestration aspect. For this reason, further research could lead to a classification of possible sub-aspects corresponding to each aspect of the 5+3 orchestration framework. In addition, the experience gained during the research of the orchestration in ULEs could lead to a joint work with other researchers in the field for proposing design principles and general frameworks for designing orchestration infrastructures in ULEs. This could help researchers and engineers create orchestration technologies, and could lead to a future interoperability of different orchestration systems. Some research works in this line have been already started [MM13]. This line of research could allow, for instance, a standardized integration of orchestration systems such as GLUEPS-AR with other orchestration technologies, such as ambient displays or tangible interfaces [Pri13b].
- **Proposals.** The current prototypes of GLUEPS-AR and Bucket-Server consider the web-based VLE as a central element. This allowed us to simplify the implementation, and to focus on our research question. However, the need of such a central element could be an obstacle to apply the proposals to scenarios that do not use a web VLE, or that use more than one. Further research could address this issue, by exploring a technological solution for a totally distributed set of learning environments, where there is not a central element. Also, the evaluation studies have shown that in some outdoor contexts it is important to enable the possibility of working offline (without Internet connection). We plan further developments in the prototypes for enabling such kind of offline work. Another line for future research is related to the scalability of the proposals. We focused the research on three kinds of spaces, and proposed architectures that showed to be adaptable to multiple spaces and technologies. However, further research would be necessary to explore if other spaces (e.g., tabletops or Virtual Reality), or even other technologies focused on the spaces studied (e.g., AR glasses, or 3DVWs not based on geographical coordinates, such as Second Life¹⁴ or Minecraft¹⁵) would be supported by the proposed architectures. Also related

¹⁴<http://secondlife.com>. Last access April 2015.

¹⁵<https://minecraft.net>. Last access April 2015.

to the scalability, we worked mainly with educational contexts (face-to-face and blended learning) not characterized by the massive presence of students. However, the support of the architectures proposed to other massive scenarios (e.g., massive ULEs using MOOCs) should be further explored. Regarding the learning buckets, although we defined a simple set of constraints in the data model of the Bucket-Server, it could be extended, adding the complexity required for enabling a fine-tuned regulation of the degree of flexibility. We considered that a simple set was the best way to start exploring the concept, but future research could focus specifically on the possible constraints that could be configured to enhance the teacher control. Also, in the thesis we proposed a specific implementation of the learning bucket notion, but other implementations could be further explored. For instance, integrating the notion directly in learning environments, scripting languages, etc., instead of using an external tool. This could help such environments or systems improve the flexibility offered to students. However, although the research works can provide insights of the potential usefulness of the learning bucket notion in other implementations, we have not evaluated its use outside the proposed systems. Further work would be necessary to explore the applicability of the learning bucket notion to other different approaches. A current limitation of the Bucket-Server detected during the evaluation works has to do with the reuse of learning artifacts between buckets (currently only a whole bucket can be reused). However, the reuse of positioned learning artifacts would enable the access to a same artifact in different physical locations and the re-grouping of the created artifacts to be used in other activities or learning situations. Further research in such line would enable such reuse. Another line of future work has to do with the direct integration of 3DVWs with the Bucket-Server, thus extending its current scope, when used independently of GLUEPS-AR, to learning situations involving physical, web and 3DVWs spaces. Following this line, we have already integrated the Bucket-Server prototype with VGs [MC15]. Finally, the evaluation works carried out with GLUEPS-AR and Bucket-Server showed that, although the Bucket-Server was perceived as easier to use than GLUEPS-AR, further research is necessary to provide teachers with simpler and easier to use tools which may also help teachers put into practice across-spaces learning situations.

- **Security and privacy.** The thesis focuses on the teacher orchestration, and specifically, in the deployment of learning design in ULEs, as well as in the students' management of learning artifacts during the enactment. For this reason, security and privacy matters were not studied in detail. However, security and privacy are two important concerns, which are known issues identified by the TEL research community [Cha06], and that should be addressed in the future.
- **Pedagogy.** Since the thesis has a more technological than pedagogical perspective, and it is centered on teachers, many pedagogical issues, especially related to students and learning, were not explored in detail. However, the different technologies proposed and the multiple ULEs enabled by such technologies can be a rich data source for studying the learning implications of the orchestration of ULEs. This could allow to understand the learning benefits of the orchestration in such environments; to enhance the connection of formal and informal learning spaces; or to gain knowledge about how different pedagogical approaches or educational contexts can be better orchestrated in ULEs. Another future line of research deals with the necessity detected in the evaluation works of helping teachers anticipate potential problems and guide them to prepare backup plans (even without the

use of technology). Some works related to the pedagogical side of the orchestration of ULEs carried out have been already started [GL13] [GL14].

- **Evaluation.** Another point to remark detected in the different evaluation works are the intrinsic difficulties of evaluating across-spaces learning situations. Since students can work in groups in different spaces, and cover large physical areas, it is challenging for the researchers in this field to gather evaluation data. In our case, we counted with a team of multiple researchers, up to six simultaneously in some cases, collecting data that afterwards had to be compiled and analyzed. We have started a new line of research aiming to help researchers in the evaluation of innovations in ULEs [JA15].

1.7 Structure of the rest of the document

The rest of the dissertation is a collection of seven self-contained chapters in format of articles. Four of the chapters are published in international JCR-indexed peer-reviewed journals at the moment of the presentation of the dissertation (J1-J4 in Section 1.4.3). The other three chapters will be submitted to international indexed peer-reviewed journals. We expect that a format of this kind makes the dissertation more enjoyable than the traditional format, and may foster the dissemination of the work. We have strived to maintain the sense of unity of the whole research work. The introduction describes the overall research process followed, and each chapter is preceded by an introduction to reinforce the homogeneity of the dissertation and to explain the role of the chapter in the whole research process. To structure the rest of the document we chose between presenting the work based on the order of the research process (Figure 1.3) or on the order of the global results of the thesis (Figure 1.4). We opted finally for the former, because we consider it is the clearest option, the less complicated to understand, and it gives simultaneously an outline of the research process followed, and of the different contributions and evaluations conducted. Figure 1.5 illustrates the structure of the rest of the document, showing the parts of the research process (see Figure 1.3) that are covered in each chapter.

The following is a list indicating the publication corresponding to each chapter of the rest of the document, and a brief summary of the chapter content.

- **Chapter 2.** Muñoz Cristóbal, J.A., Prieto Santos, L.P., Asensio Pérez, J.I., Martínez Monés, A., Jorrín Abellán, I.M., Dimitriadis, Y. Deploying learning designs across physical and web spaces: Making pervasive learning affordable for teachers *Pervasive and Mobile Computing*. 14:31-46, 2014.
GLUEPS-AR proposal for web and physical spaces, and evaluation using a feature analysis and a pilot study.
- **Chapter 3.** Game of Blazons: Helping teachers conduct learning situations that integrate web tools and multiple types of augmented reality. To be submitted.
Evaluation of the GLUEPS-AR features in an authentic setting with teachers and students.
- **Chapter 4.** Learning buckets: Helping teachers introduce flexibility in the management of learning artifacts across spaces. To be submitted.

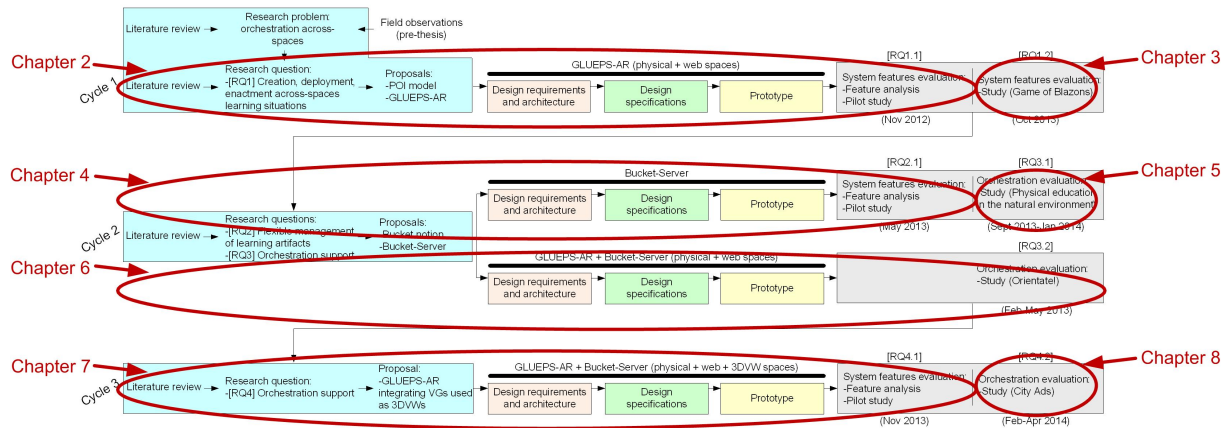

Figure 1.5: Structure of the rest of the document.

Learning buckets and Bucket-Server proposals, and evaluation using a feature analysis and a pilot study.

- **Chapter 5.** *Bricolaging learning buckets for orchestrating learning across spaces.* To be submitted.

Evaluation of the support provided to orchestration by the learning buckets in an authentic study with teachers and students, involving web and physical spaces.

- **Chapter 6.** Muñoz Cristóbal, J.A., Jorrín Abellán, I.M., Asensio Pérez, J.I., Martínez Monés, A., Prieto Santos, L.P., Dimitriadis, Y. Supporting teacher orchestration in Ubiquitous Learning Environments: A study in Primary Education *IEEE Transactions on Learning Technologies*. 8(1):83-97, 2015.

Evaluation of the support provided to orchestration by GLUEPS-AR integrated with the Bucket-Server in an authentic study with teachers and students, involving web and physical spaces.

- **Chapter 7.** Muñoz Cristóbal, J.A., Prieto Santos, L.P., Asensio Pérez, J.I., Martínez Monés, A., Jorrín Abellán, I.M., Dimitriadis, Y. Coming down to Earth: Helping teachers use 3D virtual worlds in across-spaces learning situations *Educational Technology & Society*. 18(1):13-26, 2015.

GLUEPS-AR proposal for web, physical and 3DVW spaces, and evaluation using a feature analysis and a pilot study.

- **Chapter 8.** Muñoz Cristóbal, J.A., Martínez Monés, A., Asensio Pérez, J.I., Villagrà Sobrino, S.L., Hoyos Torío, J.E., Dimitriadis, Y. City Ads: Embedding virtual worlds and augmented reality in everyday educational practice *Journal of Universal Computer Science*. 20(12):1670-1689, 2014.

Evaluation of the support provided to orchestration by GLUEPS-AR integrated with the Bucket-Server in an authentic study with teachers and students, involving web, physical and 3DVW spaces.

Chapter 2

Deploying learning designs across physical and web spaces: Making pervasive learning affordable for teachers

This chapter describes part of the research works carried out during the first cycle of the research process (see Figure 2.1) aiming to help teachers in the orchestration of learning situations that may involve physical and web spaces. The chapter focuses on some orchestration aspects that we identified as challenging for the existing approaches aiming at helping teachers in the orchestration of across-spaces learning situations: the affordable deployment of the teachers learning designs into pervasive learning environments; the alignment of the supported activities and technologies with the teachers current practice; and the “flow” of learning artifacts between the different physical and web spaces. In order to help overcome such challenges, the chapter presents the Point of Interest (POI) model conceptual proposal, and the GLUEPS-AR system, a technological proposal which implements the POI model. This chapter centers such proposals on physical and web spaces. The POI model and GLUEPS-AR are two main contributions of the thesis (see Figure 2.2). In this chapter, we also describe the evaluation carried out to explore the support provided by GLUEPS-AR to the identified limitations of alternative approaches, by means of a feature analysis and a pilot study. The feature analysis consisted in a systematic comparison of the support provided by GLUEPS-AR and alternative proposals addressing the aforementioned challenges. The pilot study involved the co-design and co-deployment with a teacher, using GLUEPS-AR, of three across-spaces learning situations. The study did not involve the enactment of the learning situations with students. Due to space restrictions, the scenario describing in detail the learning situations is included in Appendix A. Also, Appendix B contains additional GLUEPS-AR’s technical details, and the general templates for questionnaires used during the evaluation are included in Appendix C.

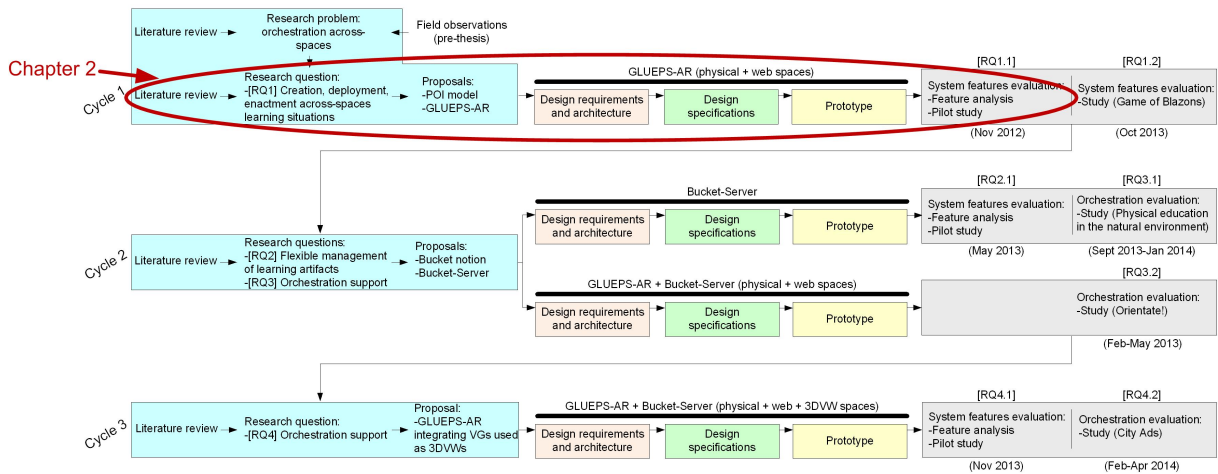

Figure 2.1: Part of the research process covered by Chapter 2.

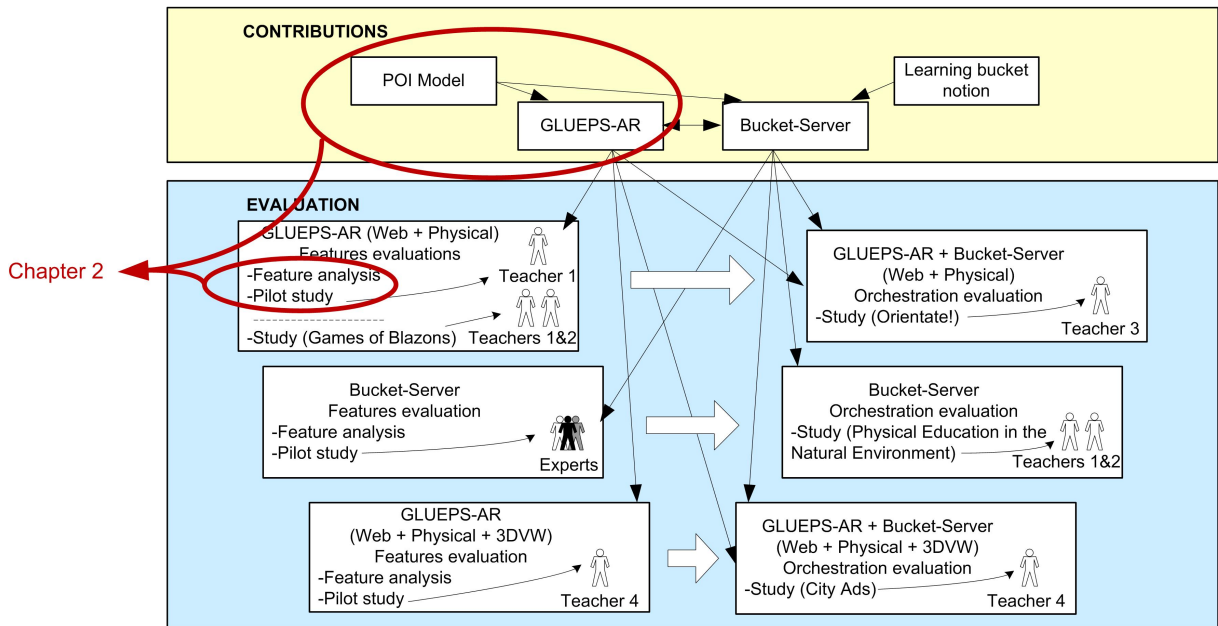

Figure 2.2: Contributions and evaluation works covered by Chapter 2.

The content of this chapter was published in the following journal article:

Juan A. Muñoz-Cristóbal, Luis P. Prieto, Juan I. Asensio-Pérez, Alejandra Martínez-Monés, Iván M. Jorrín-Abellán, Yannis Dimitriadis, Deploying learning designs across physical and web spaces: Making pervasive learning affordable for teachers, *Pervasive and Mobile Computing*, Volume 14, October 2014, Pages 31-46, ISSN 1574-1192, <http://dx.doi.org/10.1016/j.pmcj.2013.09.005>. (<http://www.sciencedirect.com/science/article/pii/S1574119213001181>)

Pervasive and Mobile Computing 14 (2014) 31–46



ELSEVIER

Contents lists available at ScienceDirect

Pervasive and Mobile Computing

journal homepage: www.elsevier.com/locate/pmc

Deploying learning designs across physical and web spaces: Making pervasive learning affordable for teachers



Juan A. Muñoz-Cristóbal^{a,*}, Luis P. Prieto^a, Juan I. Asensio-Pérez^a,
Alejandra Martínez-Monés^b, Iván M. Jorrín-Abellán^c, Yannis Dimitriadis^a

^a School of Telecommunications Engineering, Universidad de Valladolid, Paseo de Belén 15, 47011 Valladolid, Spain

^b School of Computer Engineering, Universidad de Valladolid, Paseo de Belén 15, 47011 Valladolid, Spain

^c Faculty of Education and Social Work, Universidad de Valladolid, Paseo de Belén 1, 47011 Valladolid, Spain

ARTICLE INFO

Article history:

Available online 20 September 2013

Keywords:

Pervasive learning environment
Virtual learning environment
Augmented reality
Ubiquitous learning
Across spaces

ABSTRACT

Pervasive computing devices and communication infrastructures enable learning situations that occur in both the physical and the virtual world. However, deploying these pervasive situations is still a challenge for teachers. This paper presents GLUEPS-AR, a system for deploying learning designs across physical and web spaces, using mainstream Virtual Learning Environments, Web 2.0 artifacts and Augmented Reality applications. GLUEPS-AR has been evaluated through a mixed methods study on the deployment of three authentic pervasive learning situations. Results highlight that GLUEPS-AR supports teachers in deploying their pedagogical ideas on pervasive learning environments, overcoming the main limitations of existing approaches.

© 2013 Elsevier B.V. All rights reserved.

1. Introduction

Learning is not tied to the walls of a classroom or the limits of a Virtual Learning Environment (VLE). Learning may occur at every location and time [1]: in the classroom, on a fieldtrip, in a museum, at home, in the streets of a city, on Wikipedia, etc. Learning may happen within one of these spaces,¹ but also *across* them [4,5,1]. When these learning spaces overlap, forming a single entity, they constitute *pervasive learning environments* [6,7].

Augmented Reality (AR) [8,9] is a technology that can facilitate the creation of pervasive learning environments, allowing the overlapping of virtual information in a physical environment. The affordances of AR for learning have been explored in multiple research initiatives [10–13]. For example, AR can be used to convert a playground into a virtual savanna [14], or to foster spatial skills in mathematics and geometry by interacting with 3D virtual objects [11]. The evolution of mobile devices during recent years has made AR widely available. Moreover, such mobile devices currently allow the capture of information from physical spaces (e.g. taking pictures), which can be used in subsequent activities, e.g., in a web learning space [5,15].

Despite the ubiquitous presence of information and communication technologies (ICT) that could facilitate pervasive ways of learning [7,16], these pervasive learning environments are not at all widespread among teachers. One likely reason for this lack of adoption is the complexity of implementing such pervasive technologies in a way that supports their concrete

* Corresponding author.

E-mail addresses: juanmunoz@gsic.uva.es (J.A. Muñoz-Cristóbal), lprisan@gsic.uva.es (L.P. Prieto), juaase@tel.uva.es (J.I. Asensio-Pérez), amartine@infor.uva.es (A. Martínez-Monés), ivanjo@pdg.uva.es (I.M. Jorrín-Abellán), yannis@tel.uva.es (Y. Dimitriadis).

¹ We consider a “space” as the dimensional environment in which objects and events occur, and in which they have relative position and direction [2]. This definition is not limited to the physical world, also the virtual (computerized) one is considered. Thus, a space would be a container for individuals and their tasks [3], and also for artifacts.

1574-1192/\$ – see front matter © 2013 Elsevier B.V. All rights reserved.
<http://dx.doi.org/10.1016/j.pmcj.2013.09.005>

pedagogical ideas and restrictions, which is very demanding and error-prone. The pragmatic restrictions of authentic educational settings (e.g. time restrictions, class management issues, etc.), together with the fact that an average teacher is not an expert in ICT, further limits the acceptance [17] of these technologies in educational practice.

Multiple research initiatives have strived to support the implementation of pervasive learning environments [5,18–22]. These systems enable teachers to define the learning activities to be performed through pervasive technologies, using some kind of authoring tool. However, these initiatives are limited in one or more of the following aspects: they are usually tied to particular enactment systems (e.g. a concrete AR application to be used by students when performing the learning activities); they support a very narrow variety of learning activities and/or pedagogical approaches; they are not compatible with enactment systems that are currently widespread in authentic educational settings; and they do not support the flow of learning artifacts between activities conducted in different spaces of the pervasive environment. Such limitations restrict the range of learning situations to which the initiatives are applicable, thus affecting their adoption and use in authentic teaching practice.

An alternative to these ad-hoc approaches for the transformation of teachers' ideas into pervasive learning environments that support them, would be to express those ideas in a way that is independent of the enactment system, as it is often done, e.g., in the field of learning design [23,24]. There exist multiple authoring tools that enable the definition of pedagogical ideas for a set of activities (also called "learning designs" generically) in a variety of formats, and for different pedagogical approaches.² These representations of the pedagogical intentions could then be semi-automatically transformed into different enactment systems as required by each educational context. This kind of approach has been applied most commonly to web-based learning activities, now dominated by the use of VLEs (e.g. Moodle,³ Blackboard,⁴ LAMS⁵ or Sakai⁶) and Web 2.0 artifacts (e.g. blogs, wikis or Google applications) [25]. Indeed, there exist systems that support the semi-automatic implementation (also called "deployment" [26]) of multiple formats of learning designs throughout multiple distributed (web-based) learning environments (DLEs) [27] that encompass widely-used VLEs and Web 2.0 artifacts. Thus, we could consider how this kind of approach could be used also beyond web-based learning environments, supporting teachers in the deployment of pervasive learning environments.

This paper presents the architecture and prototype implementation of GLUEPS-AR, a system to support teachers in the deployment of pervasive learning environments. GLUEPS-AR semi-automatically deploys learning designs defined in a variety of authoring tools, into multiple kinds of pervasive learning environments (formed by web-based DLEs and AR-enabled physical spaces). AR is used as a bridge between spaces (or between different moments within a same physical space), allowing the flow of learning artifacts between web and physical spaces, in a controlled way, defined by the teacher in the learning design. Such a bridge allows the consideration of the pervasive learning situation as a whole (holistic). GLUEPS-AR reuses existing technologies (learning design authoring tools, widespread VLEs, Web 2.0 artifacts and AR applications), in order to keep at bay the technological complexity of the environment teachers face (rather than proposing new authoring or enactment tools). By overcoming the aforementioned limitations of current pervasive learning environment implementation efforts, GLUEPS-AR provides a more general approach that we expect can be more easily accepted by teachers in authentic educational situations. As a consequence, we expect in addition that such an approach would foster a wider adoption of pervasive learning environments in real practice.

This paper also presents the evaluation of GLUEPS-AR in three authentic learning situations, involving a non-ICT-expert teacher in the design and deployment of a pervasive learning environment that supports those situations. This evaluation aims to assess whether GLUEPS-AR enables teachers to deploy authentic pervasive learning situations involving different physical (AR-enabled) and web spaces, with a reasonable amount of effort.

The structure of the paper is as follows: in the next section, a review of alternatives available for the deployment of pervasive learning environments is presented, including a categorization of their main limitations; Section 3 describes in detail the GLUEPS-AR architecture, its data model and a prototype implementation of the system. Afterwards, the methodology and results of the evaluation study are explained in Section 4, followed by a discussion of the results and implications (Section 5). Finally, Section 6 contains the main conclusions and future work in this line of research.

2. Systems supporting the deployment of pervasive learning environments

There exists an increasing corpus of research work dealing with ICT-enhanced learning situations that go beyond the walls and times of the physical classroom [14,28,29,13,30–32]. However, most of these works do not tackle the issue of how costly it is for an average teacher (one that is not an expert in ICT) to put these situations into practice in authentic educational settings. Only very recently is research starting to consider the deployment of these kinds of pervasive learning situations by teachers (mainly in physical spaces), by means of authoring tools that enable teachers to design and deploy such pervasive learning activities. We review these works below in chronological order, emphasizing their features related to the deployment of pervasive learning situations by teachers.

² See, for example, the tools registered in the Learning Design Grid website (<http://www.ld-grid.org/resources/tools>, Last visit 10/2012).

³ <https://moodle.org> Last visit 10/2012.

⁴ <http://www.blackboard.com> Last visit 10/2012.

⁵ <http://www.lamsfoundation.org> Last visit 10/2012.

⁶ <http://www.sakaiproject.org> Last visit 10/2012.

2.1. Authoring tools for pervasive learning environments

Kurti, Milrad and colleagues [5,33] studied how to support learning situations conducted across different contexts, focusing on the use of mobile devices and learning situations that involve indoor and outdoor activities. They developed a system (the Learning Activity System, or LAS) that facilitates the design and enactment of learning situations across contexts. LAS allows information to be captured from physical contexts by means of different sensors, and presents such information in a web platform integrating different web APIs (such as Google Maps⁷). However, the deployment of the learning situations requires an ICT expert, since LAS lacks a proper authoring tool (i.e., the definition of a scenario requires programming expertise). In this line, the same authors have integrated LAS with the CeLS system (a web-based VLE, see [34]), to support learning design and enactment using scripts [35]. They have also explored the transitions of learning situations across contexts, including the flow of certain artifacts between spaces, as well as the use of AR [15].

Tissenbaum and Slotta have proposed a “smart classroom” approach [36,18], which includes multiple technologies and devices, which are guided by a learning design, and which features means of automatic deployment. Thus, instead of studying multiple contexts (e.g. outdoor and indoor), this approach studies a classroom as an ecosystem of technologies, transforming such a classroom into a multi-space learning environment with projectors, computers, software applications, tabletops and mobile devices.

ARIS [19,37] and Gymkhana [38] are systems aimed at creating and playing gymkhana-like games with AR. Albeit independent, these efforts are similar to each other, and to precursor works such as MIT-AR [39] or ROAR,⁸ focused on game-based learning. However, while MIT-AR and ROAR only supported variations in a specific game, ARIS and Gymkhana provide an advanced authoring tool that enables the creation and deployment of different games by non-ICT expert teachers.

QuestInSitu [20] is a system for the definition and deployment of assessment activities based in geolocated questionnaires. With this system, teachers may use a web platform to create and position questions along a route. Students, virtually using the web platform, or physically with mobile devices and GPS, have then to follow the route and answer the questions in the corresponding geographical locations (*in situ*). QuestInSitu supports different types of positioning (e.g. geoposition and markers).

Yiannoutsou and Avouris [21] have improved previous game-based learning approaches based on AR, which were not originally focused on teachers [40]. Now, different actors (e.g. museum visitors, students, teachers, etc.) may design games using an authoring tool wherein AR artifacts are defined and positioned using different technologies (geolocation, RFID, etc.). An example of a learning situation created with such an authoring tool is the CityScrabble game [41].

Finally, ARLearn [22] is a system to create and run learning games featuring geolocated AR and Augmented Reality (AV) [42]. ARLearn provides an authoring tool, and two runtime environments: a mobile application (for the AR version), and a user interface based on Google Street View⁹ (for the AV version). The authoring tool and the AR version of the system are very similar to the ones in ARIS, with the AV version of the games being the main difference with existing approaches.

2.2. Limitations of existing systems for authentic educational practice

The research work presented above tackles, in one way or another, the problem of deploying learning situations in pervasive learning environments. However, some limitations may restrict their use by teachers in authentic settings:

- All the described approaches provide teachers with *authoring tools tied to specific enactment technologies and/or a narrow variety of learning activities* (with the pedagogical restrictions that this imposes): a specific game in a city in CityScrabble, gymkhanas in Gymkhana, or geopositioned questionnaires in QuestInSitu. Furthermore, a learning design defined using one of these authoring tools cannot be deployed in a different proposal's enactment system (e.g. to use a LAS design in the “smart classroom”, or vice versa). This lack of a general approach to deployment forces teachers to learn a new authoring and enactment tool for each new kind of activity to be incorporated, thus limiting the potential acceptance of these systems.
- In general, existing approaches *break with enactment technologies that are currently widespread in authentic educational settings*, such as VLEs (e.g. Moodle, Blackboard) or Web 2.0 artifacts (e.g. blogs, wikis, Google Docs). Most of the reviewed approaches propose their own enactment technologies. Only ARLearn uses a mainstream tool like Google Street View, but is limited to only *that* implementation of a virtual environment. The system proposed by Kurti and colleagues is the only one in which a VLE (CeLS) is introduced—but then again, the system is limited to using just that (not very widespread) implementation of a VLE. This restriction to one specific enactment technology may hamper teacher acceptance due to institutional restrictions (e.g. enforced institution-wide usage of a concrete VLE implementation) or, if such a technology is completely new, due to a lack of experience with it [43,44,4].
- Most proposals described above have a limited support to the connection of learning activities across spaces. This connection is exemplified fundamentally by the *flow of artifacts between activities conducted in different spaces* (e.g. creating a document about a topic in the classroom, and reviewing it in a different, more meaningful physical space). Such

⁷ <https://maps.google.com> Last visit 10/2012.

⁸ <http://gameslab.radford.edu/ROAR/> Last visit 10/2012.

⁹ <http://www.google.com/streetview> Last visit 10/2012.

a connection of learning activities across spaces facilitates a holistic view of the learning situation and a more seamless learning [4,1], contributing to the continuity of the learning experience across the learning spaces [4], and therefore, to the continuity of the learning objectives. All described approaches, except for LAS and smart classroom proposals, have a very limited support (if any) for this flow of artifacts. Indeed, Kurti and colleagues studied the connection of outdoor and indoor contexts, and thus their system allows one to capture information from an outdoor physical context (e.g. taking pictures, videos, etc.), presenting it in a subsequent activity in another context through a web platform. Later research by the same group combines the use of AR in a classroom, relating it with prior activities done in a different context [15]. However, although related conceptually with previous activities, the AR artifacts (3D models) do not flow automatically between different activities.

Therefore, to the best of our knowledge, none of the aforementioned approaches supports the usage of multiple different enactment technologies, and the support for a wide variety of learning activities is quite limited in most of them. In addition, none of these approaches uses widespread enactment technologies (such as broadly-used VLEs, Web 2.0 tools or AR applications), with the sole exception of ARLearn, which implements Google Street View. Finally, only LAS and smart classroom support (with restrictions) the flow of learning artifacts between spaces. Tackling all these limitations may contribute to making the deployment of pervasive learning situations affordable for teachers, thus contributing to the acceptance of pervasive learning environments.

3. GLUEPS-AR

In order to overcome these limitations, we present the Group Learning Unified Environment with Pedagogical Scripting and Augmented Reality support (GLUEPS-AR). GLUEPS-AR is a system for the semi-automatic deployment of learning designs in different pervasive learning environments composed of web-based DLEs and AR-enabled physical spaces. The system extends an existing proposal (GLUE!-PS [26]), aimed at supporting the deployment of learning designs defined using multiple authoring tools, in different kinds of web spaces. GLUEPS-AR extends such an approach, considering not only web spaces, but also physical ones, therefore extending the scope of the target settings from (web-based) DLEs to pervasive learning environments. GLUEPS-AR uses AR in mobile devices (e.g., tablets and smartphones) as the main technology to connect these web and physical spaces, allowing the flow of learning artifacts between them, achieving a single, pervasive learning environment.

3.1. Architecture of the system

Fig. 1 shows the basic GLUEPS-AR architecture. The system's architecture prioritizes the extensible integration of existing systems, in the same way that its precursor (GLUE!-PS) did for web environments. It is based on a central element (GLUEPS-AR Manager) and a set of adapters that enable a low coupling between the external elements (authoring tools, enactment technologies) and the central component. The GLUEPS-AR Manager translates learning designs created using different authoring tools (which may use different data models to represent designs) to the native GLUEPS-AR data model. Then, these translated designs are deployed into the different pervasive learning environments. The GLUEPS-AR Manager has a Graphical User Interface (GUI) for the teacher, to particularize and configure the designs (e.g. assigning specific students to groups, or tools to be used in each activity). The multiple learning design (LD) authoring tools are integrated through LD-adapters (Fig. 1, left) that handle the specifics of translating from each authoring tool format to the common one used by GLUEPS-AR. Conversely, multiple web-based DLEs (composed of VLEs and third party tools) may be integrated with DLE-adapters (Fig. 1, right), and multiple AR applications may be integrated using AR-adapters that handle the abstractions and data formats of each specific AR implementation.

The architecture of GLUEPS-AR has been designed to overcome the described limitations of the approaches reviewed in the previous section:

- In GLUEPS-AR, authoring tools are not tied to specific enactment technologies and/or specific kinds of learning activities, since the system allows the integration of multiple authoring and enactment tools (even those not specifically designed for activities in multiple spaces). A learning design defined in any of the integrated authoring tools could be deployed in any of the enactment technologies integrated with GLUEPS-AR. This multi-to-multi approach makes the solution extensible, adaptable, and not coupled to specific technological implementations or pedagogies. The average effort required for integrating new authoring or enactment tools is relatively low: by developing only one new adapter, multiple new combinations of design and enactment tools are added to the system.
- GLUEPS-AR enables reusing existing technologies, rather than breaking with currently widespread enactment technologies. Thus, successful VLEs, Web 2.0 artifacts or AR applications (e.g. general purpose AR browsers such as Junaio,¹⁰ Layar¹¹ or Wikitude¹² [45]) can be used within GLUEPS-AR. This has a positive effect on the adoption of the overall proposal, since teachers will be able to use familiar tools in their scenarios.

¹⁰ <http://www.junaio.com> Last visit 10/2012.

¹¹ <http://www.layar.com> Last visit 10/2012.

¹² <http://www.wikitude.com> Last visit 10/2012.

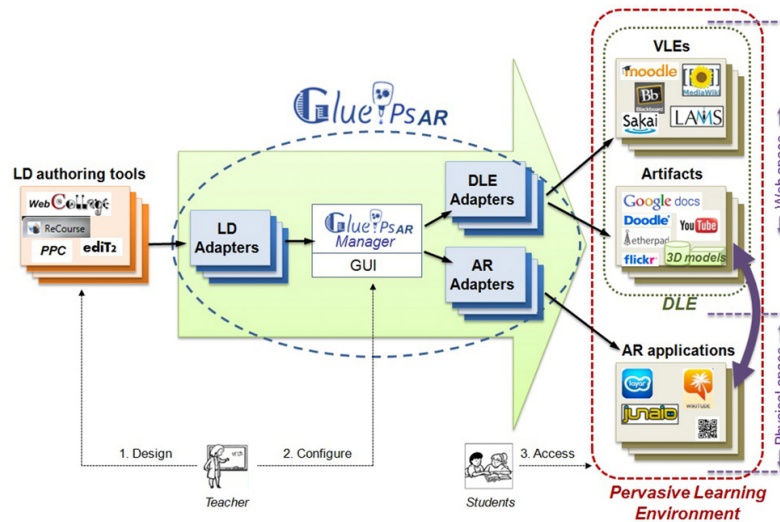

Fig. 1. GLUEPS-AR system architecture.

- Augmented reality is used in GLUEPS-AR, not only to show virtual objects over physical environments (e.g. 3D models, questionnaires or related information), but also to enable the flow of learning artifacts between spaces. Thus, the same learning artifact (e.g. a Google Docs document) may be used in an activity performed in a physical space by a particular group, and be reused simultaneously or in a subsequent activity, in a different space (e.g. a VLE), or within the same space by another group. This flow, guided by the teacher's pedagogical intentions captured in the learning design, thus serves as a scaffold for seamless, across-spaces learning [4,1].

3.2. GLUEPS-AR data model

At the data level, the process of deploying learning designs through GLUEPS-AR implies two data translations: a first one from the output format of the authoring tool to the GLUEPS-AR data model, and a second one from the GLUEPS-AR data model to the DLE and AR application data models. Thus, the GLUEPS-AR data model is a key element of the system. GLUEPS-AR extends the GLUE!-PS data model, also known as its Lingua Franca [26], to include the necessary elements to represent physical spaces and AR-related concepts.

Commonly, AR applications handle the concept of POI (Point of Interest) [45] to refer to a virtual artifact situated in a certain physical position. However, each AR application has a different data model for POIs (i.e. they model them using different attributes). Since GLUEPS-AR aims to deploy learning designs in pervasive learning environments, potentially featuring multiple AR applications, we have analyzed existing, publicly available data models for representing artifacts in physical locations, in order to define a generic data model for POIs. This analysis followed a hybrid approach: (1) we studied existing positioning data models and standards not defined for a specific software application or tool (we could call it a top-down approach); and (2) we analyzed data models of different existing AR software applications (i.e. a bottom-up approach). After this analysis (see Fig. 2), we defined a generic POI data model, giving priority to the most commonly appearing features and attributes, that are at the same time useful for positioning learning artifacts in physical environments (using AR). The resulting model should be complete enough to adapt from GLUEPS-AR to any AR application data format, while avoiding unnecessary detail that would complicate the development of AR-adapters.

Fig. 2 (left) shows the basic generic POI data model proposed, and whether its attributes are modeled or not by the analyzed data models. In this generic model, a POI has a unique *ID*, an associated *icon* (an image to represent the POI in the AR application), a *name* and a *description*. There may be different types of POIs (e.g. 3D models, images) that the AR browser needs to identify (e.g., for different rendering methods in AR), marked in the *POI-type* attribute. Since POIs denote virtual artifacts, the POI also includes the *location* of the artifact (usually a URL). Given that the POI denotes an artifact augmenting a physical space, the POI definition will also need a *position* in the physical space. The POI may be positioned in the physical space by different mechanisms, such as geolocation, by using markers, or by image recognition. Therefore, the POI will also have a *position-type* to identify the mechanism to be used. In learning scenarios it is sometimes interesting to show the POI only if the students are within a certain range of the POI (denoted using the *max-distance* attribute). The *date* attribute provides timing information (e.g., when was the POI created, showed or updated). Finally, the representation of the virtual artifact in the physical space may also be configured, rotating (*rotation* attribute), moving (*translation* attribute) or scaling

POI	Linkedgeodata [62]	Braun POI ontology [63]	ASPP Places [73]	GeoJSON [64]	KML [71]	W3C POI [75]	ARML 2.0 draft [72]	EEMML [67]	Kurt context model [33]	Junao	Layer	ARML (Wikitude) [69]	Mixare [70]	Khairna [68]	LibriGeoSocial [65]	Beleguise [74]	ARIS	ARTissa [61]	Popcode [61]	ARlearn [60]	ChyScrabble [41]	
ID	X	X	X	X	X	X	X	X	X	X	X	X	X	X	X	X	X	X	X	X	X	X
POI-type	X	X	X	X	X	X	X	X	X	X	X	X	X	X	X	X	X	X	X	X	X	X
icon																						
name	X	X	X	X	X	X	X	X	X	X	X	X	X	X	X	X	X	X	X	X	X	X
description	X	X	X	X	X	X	X	X	X	X	X	X	X	X	X	X	X	X	X	X	X	X
location	X	X	X	X	X	X	X	X	X	X	X	X	X	X	X	X	X	X	X	X	X	X
position	X	X	X	X	X	X	X	X	X	X	X	X	X	X	X	X	X	X	X	X	X	X
position-type																						
max-distance																						
rotation																						
translation																						
scale																						
date																						

X Element modeled ● The element could be modeled through attributes not initially defined for that function

Fig. 2. Basic generic POI data model, and table representing the analysis of their presence in existing positioning data models (see [61–75]).

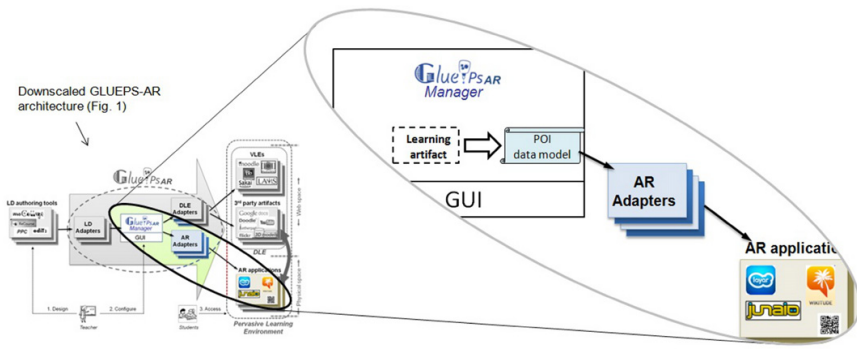

Fig. 3. Integration of AR applications in GLUEPS-AR using the basic generic POI data model.

(scale attribute) such an artifact. Fig. 3 illustrates how GLUEPS-AR implements this basic generic POI data model, converting the positioned learning artifacts to generic POIs, and offering the POIs to each AR application supported in its own specific format, by using different AR-adapters.

Fig. 4 shows the GLUEPS-AR data model in relation to the data format of its predecessor (GLUE!-PS), marking in red the modifications over the GLUE!-PS data model. The GLUE!-PS Lingua Franca is based around the modeling of a learning design (formed by different learning activities). This design can be particularized, configured and deployed within a course of a learning-environment installation (e.g. a Moodle server). Such a particularization of a design (called a deploy) contains data about the concrete participants (e.g. the students who perform the activities), their roles and grouping (groups). In this model, learning activities are mediated by resources (e.g. learning materials, tools), which can be static in design-time (objects), or instantiable during the deployment (tools). In the latter case (e.g., if it is needed that each group of students uses a different Google Docs document), a different tool-instance can be assigned to different groups or students.

As in pervasive learning environments deploys are no longer restricted to a single virtual learning environment, the GLUEPS-AR data model includes a new relationship between instanced-activity and learning-environment. Thus, each instanced-activity (i.e. an activity conducted by a specific group of students) could be deployed in a different learning-environment. Consequently, a design may be deployed across multiple learning-environments. A new environmentType attribute has also been added to the design and activity information elements, in order to allow for a generic definition of the intended target learning environments during the authoring of the learning design. The tool-instance element (which

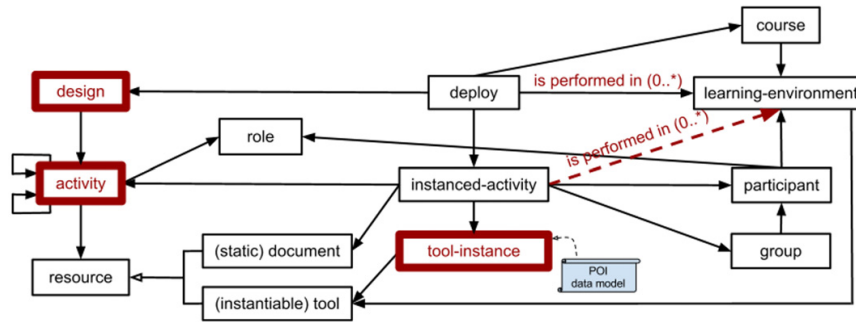

Fig. 4. GLUEPS-AR data model, with the modifications over the GLUE!-PS Lingua Franca [26] indicated through thick-lined boxes.

basically represents a virtual learning artifact) has also been modified in order to include attributes related to its representation in a physical space: this element now includes the aforementioned generic POI model attributes.

3.3. GLUEPS-AR prototype

A GLUEPS-AR prototype has been developed, extending the existing GLUE!-PS prototype [46] with the architecture and data model modifications described in previous subsections. As it happens with the GLUE!-PS prototype, GLUE! [47] is used to implement the integration of external Web 2.0 tools into existing VLEs, to form web-based DLEs. However, this prototype includes the implementation of the basic generic POI data model, and integrates the Junaio AR browser and any QR code [48] reader through the corresponding AR-adapters. Also, 3D models and AR images (images superimposed to physical environments) have been integrated as new types of artifacts that can be used in the particularization of learning designs. Consequently, GLUE!-PS's Moodle and MediaWiki DLE-adapters, as well as the system's GUI, have been modified to take into account all these new functionalities. All developments have been realized in Java and Javascript.

Using this prototype, pervasive learning designs can be defined using authoring tools already supported by the GLUE!-PS system, such as WebCollage¹³ [49] and the Pedagogical Pattern Collector¹⁴ (PPC) [50]. These designs may be deployed in two web-based VLEs (Moodle and MediaWiki), and into physical environments augmented using Junaio or any QR code reader. Web 2.0 artifacts (such as Google Docs, W3C widgets [51], or web pages), 3D models and AR images can be used as learning artifacts in both spaces (web and AR-enabled physical). All these kinds of artifacts can be configured through the GLUEPS-AR GUI, including the space wherein the artifact is going to be deployed (i.e. into a VLE vs. through AR), and other space-dependent attributes: the positioning type (currently, by markers or geoposition), the specific marker to be used, or the geographical coordinates where the artifact should appear.

Also, the GLUEPS-AR prototype supports the flow of artifacts between web and physical spaces, and between the same space in different moments. For example, a learning artifact that is used by a group of students in a certain activity may be reused in subsequent activities in different spaces, by the same or a different group. This feature also enables the flow of multimedia information generated by students *in situ* (e.g. taking photos or videos) between activities in different spaces (e.g., by taking pictures and copying them in a Google Docs document positioned in a physical environment using AR, which is afterwards reviewed in class). This kind of artifact flow, along with the capability of the GLUEPS-AR data model to represent groups of students and their artifacts (e.g. offering different artifacts to different students, even at the same time and place, or vice versa), open up multiple pedagogical possibilities, especially for collaborative and constructivist pedagogical approaches.

Fig. 5 represents the process of deploying a learning situation with the current GLUEPS-AR prototype. In the figure we see how a teacher can use a generic learning design authoring tool (WebCollage or the Pedagogical Pattern Collector), and deploy her designs in a pervasive learning environment composed by a web space (using Moodle or Mediawiki and Web 2.0 artifacts), and a physical space augmented with Junaio and/or QR codes.

3.4. General characteristics of the approach

Several general characteristics of the GLUEPS-AR proposal could be replicated in the design of systems that use existing technologies for the creation of pervasive environments: (1) The usage of central data models (e.g., GLUE!-PSs Lingua Franca, or GLUEPS-ARs POI model), abstracting the most common concepts used by related technologies, in a simple manner. This

¹³ <http://pandora.tel.uva.es/wic2/> Last visit 10/2012.

¹⁴ <http://thor.dcs.bbk.ac.uk/projects/LDSE/Dejan/ODC/ODC.html> Last visit 10/2012.

38

J.A. Muñoz-Cristóbal et al. / Pervasive and Mobile Computing 14 (2014) 31–46

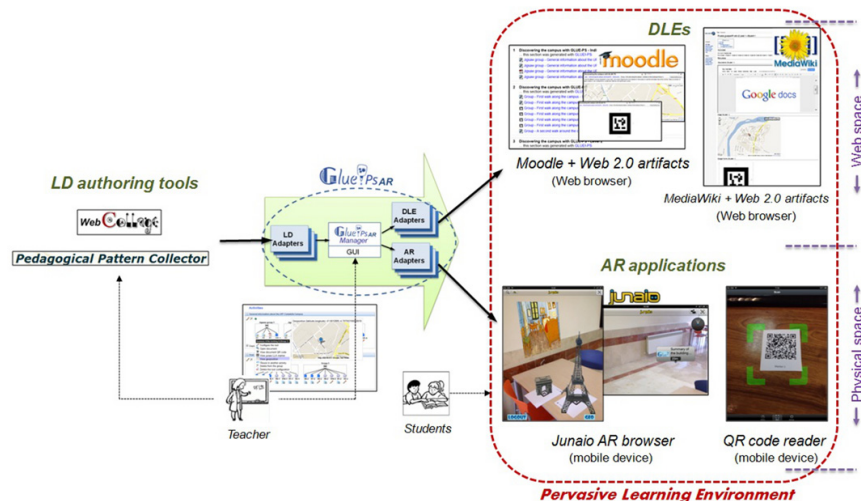

Fig. 5. GLUEPS-AR prototype deployment process in a pervasive learning environment. The current implementation supports two LD authoring tools (WebCollage and Pedagogical Pattern Collector), and pervasive learning environments composed by two DLEs (Moodle and MediaWiki, plus a variety of embedded web artifacts) and two AR applications (Junaio and any QR code reader).

allows the transformation between concepts handled by the different technologies through these central data models. (2) Using adapter-based architectures to separate the common functionality and data from the specific aspects of the technologies to be integrated. This kind of architecture can help reduce the development effort for the integration of new systems, since the common functionality is already implemented in the central element; the integration thus would just require the development of a (relatively small) adapter to deal with the specifics of the new system to be integrated. (3) Use AR to create seamless connections between physical and virtual spaces, since the advances in ICT and computing devices now allow for widespread use of AR, which has inherent affordances for connecting physical and virtual objects.

4. Evaluating the deployment of pervasive learning situations with GLUEPS-AR

An evaluation study (a case lasting two months and involving the design and deployment of three learning situations devised by a university teacher) has been carried out to illuminate the research question driving our work: *Does GLUEPS-AR make the deployment of authentic pervasive learning situations affordable for teachers, overcoming the limitations of the existing approaches?* In the following subsections we describe the context of the study, the evaluation methodology followed and, finally, its main results.

4.1. Context

The study has been conducted within the educational context of “Physical education in the natural environment”, a mandatory course corresponding to the 4th year (out of 4) of the Pre-service Primary School Teacher degree at the University of Valladolid, Spain, during 2012. In this course, the faculty conducts a series of learning situations related to orienteering in a physical environment. The pedagogical approach in these learning activities models the one that primary school teachers will have to follow in their teaching practice, in which the whole curriculum evolves from “nearby” subjects (e.g. their neighborhood) to “far away” ones (e.g. their region). Thus, in this course the teacher starts with learning activities in the classroom, explaining basic orienteering techniques and letting students carry out simple tasks and games related to the topic (e.g. drawing a sketch of the classroom). Afterwards, the students move outdoors, in the area around the Faculty of Education building, conducting other orienteering learning activities there. Finally, the teacher prepares learning activities in a natural environment (spanning a whole day, or a weekend), not only related to orientation skills, but also to the knowledge of such an environment and its relation with the rural surroundings. Each of these three phases (classroom, campus, natural environment) feature multiple learning activities, including tasks performed in the virtual space of the institutional learning platform (Moodle). The Moodle representation of the activities, alongside a set of third-party web tools, is used as the main reference guide of the course. The orienteering activities themselves are realized using pen and paper, markers and a compass, although additional technologies are being integrated progressively, such as QR codes and mobile devices (for picture taking and the scanning of QR codes).

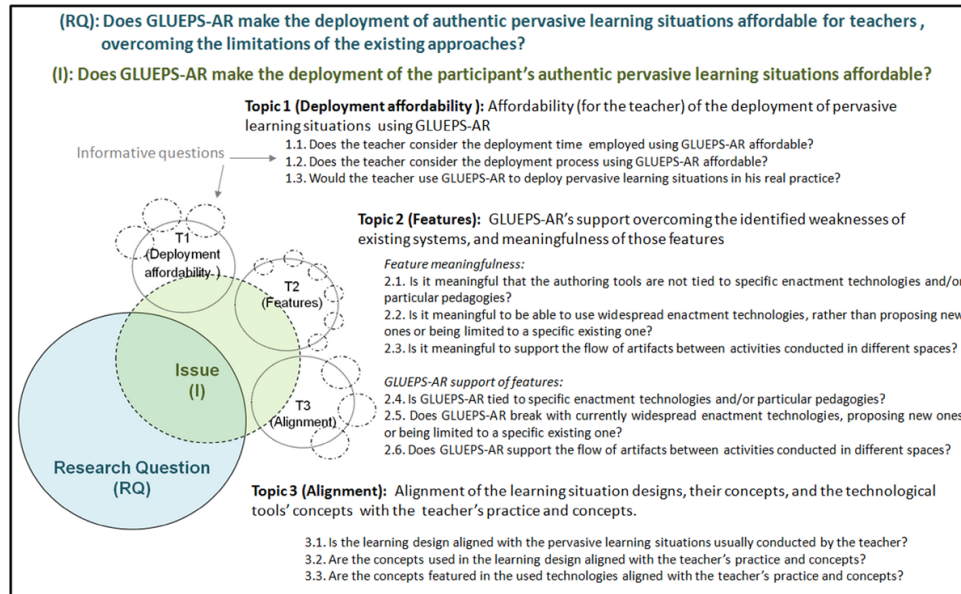

Fig. 6. Structure of the research question, issue, topics and informative questions of the evaluation study.

The following subsections detail the design of an evaluation case related to this learning context. In the evaluation, the teacher of the described course was involved in the co-design and co-deployment (i.e. together with the evaluation team), using GLUEPS-AR, of the aforementioned and inter-related learning situations (classroom, campus, natural environment).

4.2. Method

For the design of the evaluation study we have followed the Computer-Supported Collaborative Learning (CSCL) Evaluand-oriented Responsive Evaluation Model (CSCL-EREM) [52], an evaluand-centered framework to guide evaluators of CSCL innovations. This model recommends the use of a profuse set of quantitative and qualitative data gathering techniques in a mixed method approach [53]. The CSCL-EREM model is deeply inspired in a responsive approach to evaluation [54], and it assumes that the authenticity of the learning scenario in which a tool is evaluated increases the accuracy and usefulness of its evaluation. This approach also underscores the importance of responding to participants' needs (rather than describing, measuring or judging them) as a way of better understanding the setting, and to facilitate the adoption of the evaluated technology in real practice. Hence, GLUEPS-AR has been evaluated through the in-depth study of the practice of one faculty member of this course, its particular contextual characteristics, pedagogical constraints and needs. This kind of evaluation process does not pursue statistically-significant results, rather aiming to understand the particularity and the richness of concrete phenomena [55], in this case provided by the holistic evaluation of GLUEPS-AR in an authentic setting.

4.2.1. Research question

To give plausible answers to the research question featured at the beginning of this section, an issue or tension [56] can be defined as a conceptual organizer of the evaluation process (“Does GLUEPS-AR make the deployment of the participant's authentic pervasive learning situations affordable?”). Following Miles and Huberman's anticipated data reduction approach [57], our main issue is divided into various topics, which help to illuminate its multiple dimensions (see Fig. 6). In turn, each topic has been explored through a set of informative questions that help us understand it. More concretely, we have defined topics regarding the affordability (for the teacher) of the deployment of the concerned pervasive learning situations using GLUEPS-AR (Topic 1); the support offered by GLUEPS-AR to overcome the limitations of existing approaches, as well as the meaningfulness (for the teacher) of such features (Topic 2); and the alignment of the concepts used throughout the process (i.e. those of the learning situation designs and technological tools used in the deployment), with the teacher's current practice and concepts (Topic 3). Fig. 6 represents this anticipated data reduction structure.

Following the advice of the CSCL-EREM model, a profuse set of data gathering techniques have been used, in order to collect and triangulate evidence answering our informative questions. Such techniques are observations, time measurements, audio, video and screen recordings, questionnaires, interviews, and artifacts generated by the teacher (e-mails and other

40

J.A. Muñoz-Cristóbal et al. / Pervasive and Mobile Computing 14 (2014) 31–46

Table 1

Data sources for the evaluation and labels utilized to quote them along the text.

Data source	Type of data	Label
Interviews	Qualitative interviews with teacher (recorded and transcribed), to capture the opinions of the teacher in depth.	[Int]
Observations	Audio/video recordings and observation notes taken during the sessions with the teacher, to capture his reactions and other emergent issues while interacting with the system.	[Obs]
Questionnaires	Numerical ratings, qualitative explanations of the answers realized by teacher, and scoring of GLUEPS-AR's features. Used to get the initial opinions of the teacher over a wide range of matters.	[Quest] [Score]
Teacher-generated artifacts	Artifacts generated by the teacher (emails and documents), used in the co-design of the learning situations.	[Teach]
Time measurements	Quantitative deployment time measurements, to study the required effort and the affordability of the deployment process.	[Time]
Screen recordings	Qualitative and quantitative information about the design and deployment processes, to analyze them in detail.	[Screen]

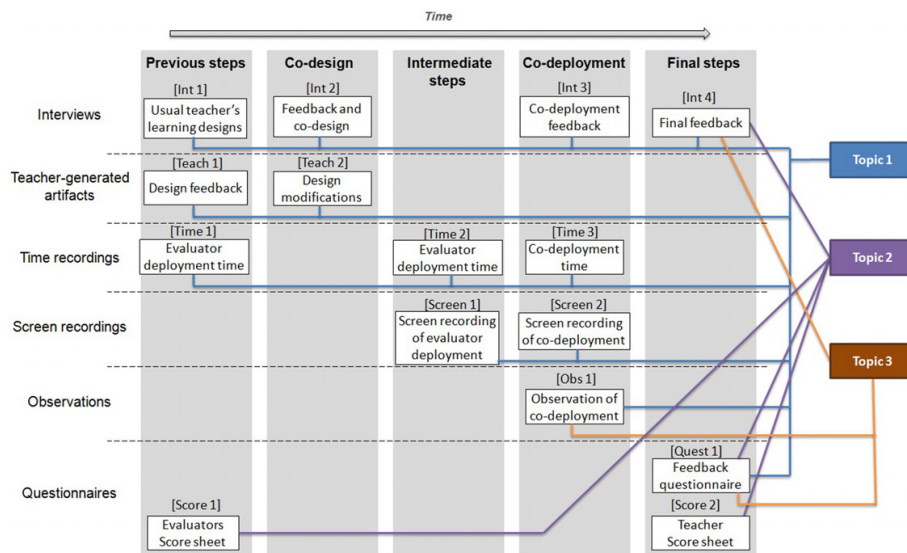
**Fig. 7.** Data gathering and evaluation flow of the study.

documents). All these different data sources provide valuable information to illuminate our evaluative issue (see Table 1). The analysis of these data has been further complemented with a feature analysis by which we aimed at a systematic comparison between GLUEPS-AR and the related works discussed in Section 2. More concretely, we have followed a combination of the screening and experimental methods of the DESMET evaluation methodology [58]. DESMET defines a set of steps and tools to define and assess a set of features relevant for the purposes of an evaluation. In the proposed evaluation schema, these features match the informative questions of Topic 2 of our study (see Fig. 6), and serve to complement and triangulate the rest of our data on that topic, in order to increase the credibility of our findings.

4.2.2. Description of the intervention

Fig. 7 illustrates the evaluation flow and the data gathering techniques used throughout the process. As the figure shows, different techniques were used for the illumination of each topic, in order to answer the informative questions, triangulating the data from different sources and methods.

We carried out an iterative design process, wherein the participant teacher was involved to varying degrees. In a first stage (*Previous steps* in Fig. 7), the teacher was interviewed about his pervasive learning practice in the course [Int 1], without describing the affordances of AR or GLUEPS-AR (to avoid biasing him towards those possibilities). Based on the information gathered during this first interview, the evaluation team designed collaboratively a series of learning situations for the course. An ICT-expert member of the evaluation team defined such a learning design in the WebCollage authoring tool, and deployed it in a pervasive learning environment (using Moodle, Junaio and QR codes readers) with GLUEPS-AR. The time employed in this first deployment of the learning situations was measured [Time 1]. A tabular/graphical representation of the evaluators-produced learning design was sent to the teacher with the aim of getting an initial assessment of its



Fig. 8. Screenshots of the GLUEPS-AR GUI in a desktop web browser (left) and Junaio user interface in a tablet (right).

alignment with his practice. His response to this learning design was essentially positive, in the ensuing communication with the evaluation team [Teach 1].

Then, in a second interview [Int 2], the evaluation team and the teacher jointly co-designed a new version of the pervasive learning activities, using the previous learning design as a basis (*Co-design* phase in Fig. 7). Afterwards, the teacher worked alone improving the design, sending back a series of modifications to the co-designed activities [Teach 2]. Then, the evaluators, following the teacher's instructions, generated a final learning design for the course (comprising the three learning situations with a total of seventeen collaborative activities expected to span more than twenty seven hours of course work). Such a final learning design was then expressed in computer-interpretable form using the WebCollage authoring tool, and deployed with GLUEPS-AR by the same ICT expert evaluator, recording the screen [Screen 1] and measuring the deployment time of the whole process [Time 2] (*Intermediate steps* in Fig. 7).

Afterwards, the teacher and the evaluation team deployed jointly this final version of the learning situations (*Co-deployment* phase in Fig. 7). In particular, the teacher deployed by himself (supported by the evaluation team) the third learning situation regarding the rural environment, using GLUEPS-AR. The resulting pervasive technological setting was reviewed by the teacher. During this co-deployment session, one of the evaluators took observation notes [Obs 1], while the computer screen was recorded [Screen 2] and the deployment time was measured [Time 3]. Fig. 8 shows the user interfaces of GLUEPS-AR and Junaio.

After this final deployment, the teacher was interviewed (*Final steps* in Fig. 7) [Int 3]. Then, he answered a web-based Likert-type questionnaire [Quest 1], and finally, he was interviewed again [Int 4] to gain a better understanding of the answers in the questionnaire.

In parallel to this process (although represented within *Previous steps* in Fig. 7), a feature analysis in screening mode (i.e. the features are identified and scored by the evaluation team [58]) was conducted [Feat 1]. The identified limitations of existing approaches to the deployment of pervasive learning environments (Section 2) were categorized as features and subfeatures. Each approach, as well as the GLUEPS-AR system, was assessed by the evaluation team, scoring the different subfeatures in a 0–5 scale, using a score sheet (as the method recommends). In order to provide these scores, some of the existing approaches were tested (QuestInSitu, ARLearn, ARIS and GLUEPS-AR), while the rest were analyzed studying their specifications and/or related literature. Also, in order to triangulate with the judgment of a relevant actor external to the evaluation team, a feature analysis of GLUEPS-AR was conducted by the teacher as a tool assessor [Feat 2]. This feature analysis was based in the experiment mode [58] of DESMET, in which the teacher scored the identified subfeatures for GLUEPS-AR using the same scale of 0–5 in a score sheet [Score 2] (represented within *Final steps* in Fig. 7).

4.3. Results

This section summarizes the main results obtained in the evaluation of GLUEPS-AR. The results are organized according to the three topics defined to analyze our research question (see Fig. 6). The findings are illustrated with excerpts of the qualitative and quantitative data that support them.

4.3.1. Deployment affordability (Topic 1)

Topic 1 deals the affordability for the teacher of deploying pervasive learning situations using GLUEPS-AR. This topic has been explored by measuring the time needed for each deployment performed, and by analyzing the teacher's opinions on the system's complexity and his expectations about the future use of the system.

Table 2 shows the time employed for the definition of the learning design using the WebCollage authoring tool. The table also accounts for the time it took to deploy the learning designs of the three learning situations into a pervasive learning environment using GLUEPS-AR. As described in the previous subsection, there were three rounds of deployment throughout the evaluation process: the first two were done by an ICT-expert member of the evaluation team, while the last one was

Table 2

Time (in min) devoted to the definition and deployment of the learning situations, using WebCollage and GLUEPS-AR, respectively.

	Learning situation 1 (classroom)		Learning situation 2 (campus outdoor)		Learning situation 3 (natural environment)	
	WebCollage	GLUEPS-AR	WebCollage	GLUEPS-AR	WebCollage	GLUEPS-AR
Initial proposal (evaluator)	15	16	14	24	24	16
Final design (evaluator)	38	28	15	19	16	15
Final design (co-deployment)	–	–	–	27	–	18

done by the teacher (with occasional help from the researchers). As the table shows, the deployment time of the third learning situation took the teacher only three minutes longer than the ICT expert (18 vs. 15 min). In the answers to the first questionnaire [Quest 1], the teacher regarded positively a total definition and deployment time below three hours (the whole process took 109 and 131 min in the first two rounds done by the expert, respectively). This judgment was also confirmed at the interview (“*I think that three hours, with the explanations you did, is acceptable. Perfectly, yes*” [Int 4]). Also, the teacher considered that the deployment process with GLUEPS-AR was easy (“*I see this part very easy*” [Int 3]), although he was mainly concerned about the time required for the definition of the learning design in WebCollage (“*I see it easy. But... to deploy. Not all teachers will have somebody which have set up the rest of the architecture (referring to the learning design in WebCollage)*” [Int 3]). Despite this concern, he appeared to be very motivated to use GLUEPS-AR to conduct these or other different learning situations, not only related with orienteering [Quest 1] (“*... It would be very useful. I would like to use it.*” [Int 3]; “*I can think of many more possibilities for applying these things. Trekking, active tourism, ...*”, “[*The teacher*] volunteers to try it by himself in order to see if he is able to design something, and to think in philosophical/educational applications of these technologies” [Obs 1]).

4.3.2. Features (Topic 2)

Topic 2 deals with the support for the identified features limiting teacher adoption (see Section 2), and the meaningfulness of such features. This topic has been studied mainly through the comparative feature analysis of GLUEPS-AR and the other existing approaches, combined with interviews and questionnaires with the teacher. This feature analysis targets identified limitations in the deployment of pervasive learning situations very narrowly; thus, it should not be taken as an indicator of the overall quality of the systems. Table 3 shows the evaluation profile obtained in the feature analysis conducted by the evaluation team [Score 1]. As it can be seen, GLUEPS-AR obtains significantly better scores than most of the alternative approaches. Such a score has been triangulated with the GLUEPS-AR feature analysis conducted by the teacher after his use of GLUEPS-AR in the co-deployment experience (last column in Table 3) [Score 2]. Only two subfeatures (“*The system allows different pedagogical approaches*” and “*Inside a same pedagogic approach, the system allows to use different techniques (questionnaires, games, collaborative writing, debate, etc.)*”) were scored 3 by the teacher (in a 0–5 scale; 3 corresponds to “*The system has a partial support to this feature*”). The interview data showed that the teacher was purposefully cautious about the pedagogical effects of the technology, at least until he could see it in action with students (“*By now, I will put my score here [at 3], so as not to exaggerate. I have to see how it fares in the enactment, combining the technology with the pedagogy, in order to have further elements of judgment*” [Int 4]). All the identified subfeatures were valued as meaningful by the teacher [Quest 1], although always considering technology in a lower level of meaningfulness than pedagogy (“*[technology] depends on the person, and her thoughts as a teacher, the course, etc. That is the drawback I see in almost every point in the questionnaire. That is why I do not put the maximum score to anything. I think, based in what I have seen, that it [GLUEPS-AR] enables and helps you [...] (to a question about whether he found the pedagogical part missing from the score sheet:) Yes, that is it. That [the pedagogy] is the most important aspect*” [Int 4]).

4.3.3. Alignment with the teacher's practice (Topic 3)

To explore the alignment of the learning situation design, its concepts, and the technological tools' concepts with the teacher's own practice and notions, we gathered feedback from the teacher after the co-deployment process, through an interview and a questionnaire. Such data was combined with observations of the co-deployment, to strengthen the credibility of the results.

Results were positive regarding the alignment of the learning design to the teacher's usual pervasive learning situations and to the learning objectives of the course (“*(to a question about whether there was a connection between the learning situations and his pedagogical objectives:) Yes, I think so. It always can be fine-tuned a little more, and I am a little afraid [...] the technology dazzles you so much, that you end up doing things that are not strictly necessary for the pedagogical line that you want to follow*” [Int 4]). The teacher understood the concepts of the learning design and the different technologies involved [Quest 1] (“*You mean (whether I understand it) at a methodological level, what is a pyramid, or a jigsaw? Yes, I know all that*”, “*(to a question about whether he understands the way GLUEPS-AR represents resources:) Yes, I think so*” [Int 4]). The Junaio AR application, although valued positively (4 in a 1–6 scale), proved to be the most challenging technology for the teacher [Quest 1]. This was probably due to a lesser understanding of the pedagogical possibilities of AR (“*[Referring to AR] It is difficult to see its applicability and usefulness. Maybe [...] because it is more difficult. Maybe I am less familiarized with this kind of gadgets*”

Table 3
Evaluation profile of the different approaches: LAS, Smart classroom (SmCl), ARIS, Gymkhana (Gym), QuestInSitu (QIS), CityScrabble (CiSc), ARLearn (ARL), GLUEPS-AR (G-AR).

Subfeature	Conformance score obtained								
	Evaluation team								Teacher
	LAS	SmCl	ARIS	Gym	QIS	CiSc	ARL	G-AR	
Allow multiple technologies	0	0	0	0	0	0	0	4	4
Can use existing systems	4	4	1	1	1	1	3	4	4
Share and reuse designs in different enactment technologies	0	0	0	0	0	0	0	3	4
Deploy in different spaces	4	4	3	3	4	3	4	4	4
Allow different pedagogical approaches	4	4	2	2	2	1	3	4	3
Allow different techniques	4	4	2	2	2	0	3	4	4
Learning artifacts produced by students may be used from different spaces	4	4	1	1	3	1	3	4	4
Holistic view (related activities in different spaces)	4	4	1	1	3	1	3	4	4
System support groups in different spaces	5	5	0	5	0	0	5	5	4
Total	29	29	10	15	15	7	24	36	34
% over the total possible	66	66	22	33	33	16	53	80	76

[Int 4]). However, despite these difficulties with AR concepts, the teacher was perfectly capable of deploying an AR-enabled learning situation using GLUEPS-AR.

5. Discussion

Overall, the data from different quantitative and qualitative sources suggest that the deployment of different pervasive learning situations using GLUEPS-AR is affordable for the teacher (Topic 1). Also, the evaluation evidence shows how GLUEPS-AR overcomes the aforementioned limitations of existing approaches in deploying pervasive learning situations (Topic 2). Furthermore, the concepts handled by the different technologies involved in the deployment process appear to be aligned with the teacher’s own practice and concepts (Topic 3). Therefore, the evidence indicates that GLUEPS-AR made the deployment of the participant teacher’s authentic pervasive learning situations *affordable*. This provides a first exploration of our main research question (“Does GLUEPS-AR make the deployment of the participant’s authentic pervasive learning situations affordable?”), with encouraging results.

The course fragment featured in our evaluation, composed of three learning situations and multiple inter-related activities in various physical and web spaces, highlights some of the limitations for adoption of existing pervasive learning approaches, in the context of authentic educational settings. It also has served to show how GLUEPS-AR overcomes such limitations: it is able to interoperate with multiple widespread technologies (including the Moodle VLE already in use in the course); it supports flows of learning artifacts across web and augmented physical spaces (which was used, e.g. for *in situ* peer review activities across different learning situations in our evaluation); and it supports deploying multiple kinds of learning activities (such as blended work through Web 2.0 artifacts embedded in a VLE, collaborative work in a classroom, or outdoor orienteering tasks—all featured in the teacher’s learning design).

However, the evaluation, as a process to confront our proposal with real actors and learning situations, helped us to also identify limitations in the current GLUEPS-AR prototype, such as the scalability problems that appear when the number of students is very high. In our evaluation study, we defined a learning situation with eighteen students, while the participant teacher usually has more students in his courses (as an example, he conducted in 2012 a similar learning situation in the university campus with about seventy students). Trying to deploy this kind of complex learning design for such large cohorts, using the current GLUEPS-AR prototype would prove quite tedious and time-consuming. This is due to the fact that student grouping and tool configuration currently requires a certain amount of repetitive (albeit easy) operations. Thus, in the future, the GLUEPS-AR GUI should be modified to improve the scalability in the number of students and groups whose activities can be deployed (by automating or randomizing such a configuration). Also, although our focus in this study was the deployment (as opposed to the enactment) of pervasive learning situations, the evidence hints that the relationship between system features and their pedagogical implications needs to be analyzed in depth. New studies that cover not only the deployment, but also the enactment of pervasive learning situations, are among our plans for future research.

An interesting emergent finding was the need for greater flexibility in what students are able to do during the enactment, such as letting them take decisions about the type of learning artifacts they can create and their location (e.g., allowing students to create orienteering routes by themselves during the enactment). The participant teacher in our study usually resorted to this kind of strategy so that students helped him in the organization of the tasks, as well as for pedagogical reasons. Since current research approaches supporting the deployment of pervasive learning environments are somewhat rigid in what students are allowed to do during enactment, this is an interesting matter for further research.

As mentioned before, it is important to note that the feature analysis conducted as part of the evaluation provides scores just on the basis of the limitations identified for teacher adoption in authentic settings, and not other features or functionalities. Such scores should not be interpreted as a global measurement of the quality of each system, or a comparison of the

pervasive learning experiences they provide. Rather, it represents the relative degree of support for certain features relevant to the acceptance of systems for deploying pervasive learning situations, by teachers operating in authentic educational settings.

6. Conclusions and future work

Learning has always been naturally pervasive and ubiquitous, but only recently have mobile and web technologies reached the point where they can pervasively support learning, connecting the learning experiences in different contexts. Even if specific tools exist for the implementation of such pervasive learning environments, their limited range of applicability makes it challenging for non-technical users (such as most teachers) to develop a wide range of pervasive learning experiences. In this paper we have presented a more general approach to the deployment of such learning situations, overcoming this limitation. The results from the evaluation of a first prototype suggest that GLUEPS-AR is able to support multiple pervasive learning situations, making the deployment of such situations affordable for teachers. Even if the other approaches could adapt better to specific situations or pedagogies, GLUEPS-AR provides a general-purpose alternative, that we expect could be more easily accepted by practitioners in their everyday practice (since it integrates widespread technologies that many of them already know and use).

The positive results of this first evaluation motivates us to continue the exploration of the deployment of multiple pervasive learning situations by non-ICT-expert teachers. We intend to enact the pervasive learning situations described in the presented evaluation study with real students, and to repeat the process across different kinds of spaces, learning situations and teacher profiles. These studies will evaluate also whether teachers are able to complete the whole cycle of designing, deploying and enacting the learning situations with their students. In addition, we plan to incorporate in the approach new enactment technologies to support the orchestration [59] of the learning situations, such as ambient displays [60] and monitoring processes. Another line of future work is the extension of the generic POI model and the architecture presented here to other types of AR devices (e.g., head mounted displays such as Google Glass¹⁵) and to different types of spaces beyond the physical and web domains, including also environments such as tabletop computers and 3D virtual worlds. Finally, further research is necessary to provide increased flexibility to students during the enactment of pervasive learning situations (e.g. the selection and production of artifacts of their choice in run-time).

Acknowledgments

This research has been partially funded by the Spanish Ministry of Economy and Competitiveness Project TIN2011-28308-C03-02, the Autonomous Government of Castilla and León Project VA293A11-2, and the European Project 531262-LLP-2012-ES-KA3-KA3MP. The authors give very special thanks to the teacher involved in the evaluation, as well as the contributions from the rest of the GSIC/EMIC research team.

References

- [1] M. Sharples, I.A. Sanchez, M. Milrad, G. Vavoula, Mobile learning: small devices, big issues, in: N. Balacheff, S. Ludvigsen, T. de Jong, S. Barnes (Eds.), *Technology Enhanced Learning: Principles and Products*, Springer, Heidelberg, Germany, 2009, pp. 233–249.
- [2] S. Harrison, P. Dourish, Re-place-ing space: the roles of place and space in collaborative systems, in: *Proceedings of the 1996 ACM Conference on Computer Supported Cooperative Work, CSCW'96*, ACM, New York, NY, USA, 1996, pp. 67–76.
- [3] L. Ciolfi, Understanding spaces as places: extending interaction design paradigms, *Cognition, Technology & Work* 6 (1) (2004) 37–40.
- [4] T.-W. Chan, J. Roschelle, S. Hsi, K. Kinshuk, M. Sharples, T. Brown, C. Patton, J. Cherniavsky, R. Pea, C. Norris, E. Soloway, N. Balacheff, M. Scardamalia, P. Dillenbourg, C.-K. Looi, M. Milrad, U. Hoppe, One-to-one technology-enhanced learning: an opportunity for global research collaboration, *Research and Practice in Technology Enhanced Learning* 01 (1) (2006) 3–29.
- [5] A. Kurti, D. Spikol, M. Milrad, Bridging outdoors and indoors educational activities in schools with the support of mobile and positioning technologies, *International Journal of Mobile Learning and Organisation* 2 (2) (2008) 166–186.
- [6] A. Syvanen, R. Beale, M. Sharples, M. Ahonen, P. Lonsdale, Supporting pervasive learning environments: adaptability and context awareness in mobile learning, in: *IEEE International Workshop on Wireless and Mobile Technologies in Education, WMTE'05*, 2005, pp. 251–253.
- [7] S. Thomas, Pervasive, persuasive elearning: modeling the pervasive learning space, in: *Third IEEE International Conference on Pervasive Computing and Communications Workshops, PerCom 2005 Workshops*, 2005, pp. 332–336.
- [8] R. Azuma, Y. Baillot, R. Behringer, S. Feiner, S. Julier, B. MacIntyre, Recent advances in augmented reality, *IEEE Computer Graphics and Applications* 21 (6) (2001) 34–47.
- [9] D.W.F. van Krevelen, R. Poelman, A survey of augmented reality technologies, applications and limitations, *The International Journal of Virtual Reality* 9 (2) (2010) 1–20.
- [10] S.A. Yoon, K.J. Elinich, C. Steinmeier, J. Wang, S. Tucker, Learning science through knowledge-building and augmented reality in museums, in: *Proceedings of the 9th International Computer-Supported Collaborative Learning Conference*, Hong Kong, China, July 2011.
- [11] H. Kaufmann, D. Schmalstieg, Mathematics and geometry education with collaborative augmented reality, in: *ACM SIGGRAPH 2002 Conference Abstracts and Applications, SIGGRAPH'02*, ACM, New York, NY, USA, 2002, pp. 37–41.
- [12] S. Price, Y. Rogers, Let's get physical: the learning benefits of interacting in digitally augmented physical spaces, *Computers & Education* 43 (1–2) (2004) 137–151.
- [13] M. Dunleavy, C. Dede, R. Mitchell, Affordances and limitations of immersive participatory augmented reality simulations for teaching and learning, *Journal of Science Education and Technology* 18 (1) (2009) 7–22.

¹⁵ <http://www.google.com/glass/start/> Last visit 6/2013.

- [14] K. Facer, R. Joiner, D. Stanton, J. Reid, R. Hull, D. Kirks, Savannah: mobile gaming and learning? *Journal of Computer Assisted Learning* 20 (6) (2004) 399–409.
- [15] H. Sollervall, N. Otero, M. Milrad, D. Johansson, B. Vogel, Outdoor activities for the learning of mathematics: designing with mobile technologies for transitions across learning contexts, in: 2012 IEEE Seventh International Conference on Wireless, Mobile and Ubiquitous Technology in Education, WMUTE, March 2012, pp. 33–40.
- [16] I.M. Jorrín-Abellán, R.E. Stake, Does ubiquitous learning call for ubiquitous forms of formal evaluation? An evaluand oriented responsive evaluation model, *Ubiquitous Learning: An International Journal* 1 (3) (2009) 71–82. Common Ground Publisher, Melbourne, Australia.
- [17] T. Teo, Modelling technology acceptance in education: a study of pre-service teachers, *Computers & Education* 52 (2) (2009) 302–312.
- [18] M. Tissenbaum, M. Lui, J.D. Slotta, Co-designing collaborative smart classroom curriculum for secondary school science, *Journal of Universal Computer Science* 18 (3) (2012) 327–352.
- [19] D.J. Gagnon, Aris. An open source platform for developing mobile learning experiences, M.Sc. Thesis, University of Wisconsin–Madison, December 2010.
- [20] P. Santos, M. Pérez-Sanagustín, D. Hernández-Leo, J. Blat, QuesTInSitu: from tests to routes for assessment in situ activities, *Computers & Education* 57 (4) (2011) 2517–2534.
- [21] N. Yiannoutsou, N. Avouris, Mobile games in museums: from learning through game play to learning through game design, *ICOM-Education Online Journal* 23 (2012) 79–86. Available online at: <https://docs.google.com/open?id=0B8yHu7SudP4kTXg2b1NpVIBNbk> (Last visit 10/2012).
- [22] S. Ternier, R. Klemke, M. Kalz, P. van Ulzen, M. Specht, ARLearn: augmented reality meets augmented virtuality, *Journal of Universal Computer Science* 18 (15) (2012) 2143–2164. Special issue on technology for learning across physical and virtual spaces.
- [23] D. Laurillard, Design tools for E-learning, in: Keynote Presentation at the 19th Annual Conference of the Australasian Society for Computers in Learning in Tertiary Education, ASCILITE 2002, 2002.
- [24] R. Koper, C. Tattersall, *Learning Design: A Handbook on Modelling and Delivering Networked Education and Training*, Springer, 2005.
- [25] G. Conole, P. Alevizou, A literature review of the use of web 2.0 tools in higher education, A report commissioned by the higher education academy, The Open University, 2010.
- [26] L.P. Prieto, J.I. Asensio-Pérez, Y. Dimitriadis, E. Gómez-Sánchez, J.A. Muñoz-Cristóbal, GLUE1-PS: a multi-language architecture and data model to deploy tel designs to multiple learning environments, in: Proceedings of the 6th European Conference on Technology Enhanced Learning: Towards Ubiquitous Learning, EC-TEL'11, Springer-Verlag, Palermo, Italy, 2011, pp. 285–298.
- [27] S. MacNeill, W. Kraan, Distributed learning environments, in: CETIS Briefing Paper 2010:B01, JISC Centre for Educational Technology and Interoperability Standards, 2010.
- [28] S. Sotiriou, S. Anastopoulou, J. Knight, D. Williams, A. Theo, M. Milrad, A. Maier, S. Rosenfeld, K. Hoeksema, The connect project: bridging science education activities at schools and science centers with the support of advanced technologies, in: Proceedings of the First European Conference on Technology Enhanced Learning, EC-TEL 2006, Springer-Verlag, Crete, Greece, 2006.
- [29] E. Klopfer, K. Squire, Environmental detectives—the development of an augmented reality platform for environmental simulations, *Educational Technology Research and Development* 56 (2) (2008) 203–228.
- [30] Y.-M. Huang, Y.-T. Lin, S.-C. Cheng, Effectiveness of a mobile plant learning system in a science curriculum in taiwanese elementary education, *Computers & Education* 54 (1) (2010) 47–58.
- [31] M.B. Ibáñez, A.D. Serio, C. Delgado Kloos, Orchestration framework for learning activities in augmented reality environments, in: Across Spaces Workshop, European Conference-Technology Enhanced Learning, Palermo, Italy, 2011.
- [32] M. Pérez-Sanagustín, G. Ramirez-Gonzalez, D. Hernández-Leo, M. Muñoz-Organero, P. Santos, J. Blat, C. Delgado Kloos, Discovering the campus together: a mobile and computer-based learning experience, *Journal of Network and Computer Applications* 35 (1) (2011) 167–188.
- [33] A. Kurti, Exploring the multiple dimensions of context: implications for the design and development of innovative technology-enhanced learning environments, Ph.D. Thesis, Växjö University, Sweden, 2009.
- [34] M. Ronen, D. Kohen-Vacs, N. Raz-Fogel, Adopt & adapt: structuring, sharing and reusing asynchronous collaborative pedagogy, in: Proceedings of the 7th International Conference on Learning Sciences, ICLS'06, International Society of the Learning Sciences, 2006, pp. 599–605.
- [35] M. Milrad, D. Kohen-Vacs, B. Vogel, M. Ronen, A. Kurti, An integrated approach for the enactment of collaborative pedagogical scripts using mobile technologies, in: Proceedings of the 9th International Computer-Supported Collaborative Learning Conference, Hong Kong, China, July 2011.
- [36] J.D. Slotta, Evolving the classrooms of the future: the interplay of pedagogy, technology and community, in: K. Makitalo-Siegl, J. Zottmann, F. Kaplan, F. Fischer (Eds.), *Classroom of the Future Orchestrating Collaborative Spaces*, Sense Publishers, 2010, pp. 215–242.
- [37] C.L. Holden, J.M. Sykes, Leveraging mobile games for place-based language learning, *International Journal of Game-Based Learning (IJGBL)* 1 (2) (2011) 1–18.
- [38] G. Robles, J. Gonzales-Barahona, J. Fernandez-Gonzales, Implementing jordan kirkhanas with android smartphones: a multimedia M-learning game, in: 2011 IEEE Global Engineering Education Conference, EDUCON, Amman, Jordan, April 2011, pp. 960–968.
- [39] E. Klopfer, *Augmented Learning: Research and Design of Mobile Educational Games*, The MIT Press, Cambridge, MA, 2008.
- [40] C. Sintoris, A. Stoica, I. Papadimitriou, N. Yiannoutsou, V. Komis, N. Avouris, Museumscrabble: design of a mobile game for children's interaction with a digitally augmented cultural space, *International Journal of Mobile Human Computer Interaction (IJMHCI)* 2 (2) (2012) 53–71.
- [41] R.C. Lorente Muñoz, Design and development of end user development platform for mobile games using social media, Diploma Thesis, University of Patras, July 2012.
- [42] P. Milgram, F. Kishino, A taxonomy of mixed reality visual displays, *IEICE Transactions on Information and Systems* E77-D (12) (1994).
- [43] V. Venkatesh, F.D. Davis, A theoretical extension of the technology acceptance model: four longitudinal field studies, *Management Science* 46 (2) (2000) 186–204.
- [44] W.W.-K. Ma, R. Andersson, K.-O. Streith, Examining user acceptance of computer technology: an empirical study of student teachers, *Journal of Computer Assisted Learning* 21 (6) (2005) 387–395.
- [45] B. Butchart, Augmented reality for smartphones. TechWatch Report 1.1, JISC Observatory, 2011.
- [46] L.P. Prieto, J.A. Muñoz-Cristóbal, J.I. Asensio-Pérez, Y. Dimitriadis, Making learning designs happen in distributed learning environments with GLUE1-PS, in: Proceedings of the European Conference on Technology-Enhanced Learning 2012, EC-TEL 2012, Saarbrücken, Germany, 2012.
- [47] C. Alario-Hoyos, M.L. Bote-Lorenzo, E. Gómez-Sánchez, J.I. Asensio-Pérez, G. Vega-Gorgojo, A. Ruiz-Calleja, GLUE1: an architecture for the integration of external tools in virtual learning environments, *Computers & Education* 60 (1) (2013) 122–137.
- [48] ISO/IEC. Information technology—automatic identification and data capture techniques—QR Code 2005 bar code symbology specification, Standard 18004, 2006.
- [49] E.D. Villascarras-Fernandez, J.A. Hernandez-Gonzalo, D. Hernández-Leo, J.I. Asensio-Pérez, Y. Dimitriadis, A. Martínez-Monés, Instancecollage: a tool for the particularization of collaborative IMS-LD scripts, *Educational Technology & Society* 12 (4) (2009) 56–70.
- [50] D. Laurillard, P. Charlton, B. Craft, D. Dimakopoulos, D. Ljubojevic, G. Magoulas, E. Masterman, R. Pujadas, E.A. Whitley, K. Whittlestone, A constructionist learning environment for teachers to model learning designs, *Journal of Computer Assisted Learning* 29 (1) (2013) 15–30.
- [51] W3C. Packaged Web Apps (Widgets)—Packaging and XML Configuration, second ed., W3C Recommendation 27 November 2012, 2012.
- [52] I.M. Jorrín-Abellán, R.E. Stake, A. Martínez-Monés, The needlework in evaluating a CSCL system: the evaluand oriented responsive evaluation model, in: Proceedings of the 9th International Conference on Computer Supported Collaborative Learning—Vol. 1, CSCL'09, International Society of the Learning Sciences, 2009, pp. 68–72.
- [53] J.W. Creswell, V.L. Plano Clark, M.L. Gutmann, W.E. Hanson, Advanced mixed methods research designs, in: A. Tashakkori, C. Teddlie (Eds.), *Handbook of Mixed Methods in Social and Behavioral Research*, SAGE Publications, Inc., Thousand Oaks, CA, 2003, pp. 209–240.
- [54] R.E. Stake, *Standards-Based and Responsive Evaluation*, SAGE Publications, Inc., University of Illinois at Urbana-Champaign, USA, 2004.
- [55] E.G. Guba, Criteria for assessing the trustworthiness of naturalistic inquiries, *Educational Communication and Technology Journal* 29 (2) (1981) 75–91.
- [56] R.E. Stake, *The Art of Case Study Research*, SAGE Publications, Inc., 1995.

- [57] M.B. Miles, A.M. Huberman, *Qualitative Data Analysis. An Expanded Sourcebook*, SAGE Publications, Inc., 1994.
- [58] B. Kitchenham, S. Linkman, D. Law, DESMET: a methodology for evaluating software engineering methods and tools, *Computing & Control Engineering Journal* 8 (3) (1997) 120–126.
- [59] L.P. Prieto, M.H. Dlab, I. Gutiérrez, M. Abdulwahed, W. Balid, Orchestrating technology enhanced learning: a literature review and a conceptual framework, *International Journal of Technology Enhanced Learning* 3 (6) (2011) 583–598.
- [60] D. Hernández-Leo, R. Nieves, E. Arroyo, A. Rosales, J. Melero, P. Moreno, J. Blat, Orchestration signals in the classroom: managing the Jigsaw collaborative learning flow, in: *Proceedings of the 6th European Conference on Technology Enhanced Learning: Towards Ubiquitous Learning, EC-TEL'11*, Springer-Verlag, Berlin, Heidelberg, 2011, pp. 153–165.
- [61] artags.org. Artags. 2010. Web page available at: <http://www.artags.org> (Last visit 10/2012).
- [62] S. Auer, J. Lehmann, S. Hellmann, Linkedgedata: adding a spatial dimension to the web of data, in: *Proceedings of the 8th International Semantic Web Conference, ISWC'09*, Springer-Verlag, Berlin, Heidelberg, 2009, pp. 731–746.
- [63] M. Braun, Context-aware collaborative creation of semantic points of interest as linked data, Master's Thesis, University of Koblenz–Landau, 2009.
- [64] H. Butler, M. Daly, A. Doyle, S. Gillies, T. Schaub, C. Schmidt, The geojson format specification, revision: 1.0, 2008. Web page available at: <http://www.geojson.org/geojson-spec.html> (Last visit 10/2012).
- [65] P. de-las Heras-Quirós, R. Román-López, R. Calvo-Palomino, J. Gato, J.F. Gato, Mobile augmented reality browsers should allow labeling objects. a position paper for the augmented reality on the web W3C workshop, in: *W3C Workshop: Augmented Reality on the Web*, Barcelona, 2010.
- [66] Extra-Reality-Limited. Popcode developer guide, 2010. Web page available at: <http://docs.popcode.info/0.8.5/html/frameset.htm> (Last visit 10/2012).
- [67] Haque-Design+Research-Ltd. Extended Environments Markup Language (EEML), 2008. Web page available at: <http://www.eeml.org> (Last visit 10/2012).
- [68] A. Hill, B. MacIntyre, M. Gandy, B. Davidson, H. Rouzati, KHARMA: an open KML/HTML architecture for mobile augmented reality applications, in: *9th IEEE International Symposium on Mixed and Augmented Reality, ISMAR, IEEE, Seoul, Korea, 2010*, pp. 233–234.
- [69] M. Lechner, ARML—augmented reality markup language, in: *International AR Standards Workshop*, Seoul, Korea, 2010.
- [70] mixare. mixare. 2012. Web page available at: <http://www.mixare.org> (Last visit 10/2012).
- [71] Open-Geospatial-Consortium. OGC® KML OGC® Standard 07-147r2 Version 2.2.0, 2008.
- [72] Open-Geospatial-Consortium. OGC augmented reality markup language 2.0 (ARML 2.0) (candidate standard—request for comments), OGC® Implementation Specification 12-132r1 Version 1.0.1, 2012.
- [73] M. Pérez-Sanagustín, P. Santos, D. Hernández-Leo, J. Blat, 4SPPLces: a case study of factors in a scripted collaborative-learning blended course across spatial locations, *International Journal of Computer-Supported Collaborative Learning* 7 (3) (2012) 443–465.
- [74] D. Stevense, P. van der Tak, iBetelgeuse: an augmented reality browser for iPhone. Bachelor's Project, Delft University of Technology, 2010.
- [75] W3C. Points of interest core. W3C Working Draft 12 May 2011, May 2011.

Chapter 3

Game of Blazons: Helping teachers conduct learning situations that integrate web tools and multiple types of augmented reality

This chapter describes an evaluation study conducted at the end of the first cycle of the research process (see Figure 3.1 and Figure 3.2). The study relied on the creation and enactment, using GLUEPS-AR, of “Game of Blazons”, a learning situation that involved physical and web spaces. The situation was created and deployed by the two teachers of a course on Physical Education in the Natural Environment (a main teacher and an assistant one), who enacted it with 47 undergraduate students in a village at the north of Spain. The main teacher was the one involved in the study described in Chapter 2, and Game of Blazons is inspired by one of the learning situations addressed in that chapter. This study complements the evaluation described in Chapter 2, by focusing on the support provided by GLUEPS-AR to teachers for the affordable deployment and enactment of learning situations that embed multiple types of Augmented Reality (AR) in the teachers’ everyday practice. Thus, we explored how GLUEPS-AR helped the teachers integrate AR with their usual activities and technologies across spaces. We also explored the continuity between the different activities conducted in the different spaces. The learning situation involved web spaces and two types of augmented physical spaces: the physical environment of the village and paper. A general template of the questionnaire used in the study is included in Appendix C. The content of this chapter is presented as a paper, prepared for its future submission to an international journal.

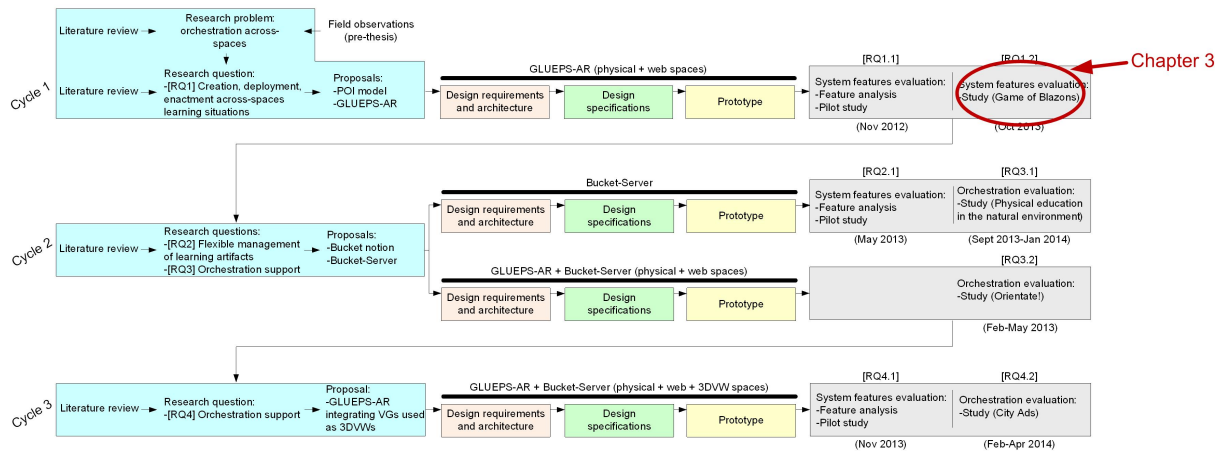

Figure 3.1: Part of the research process covered by Chapter 3.

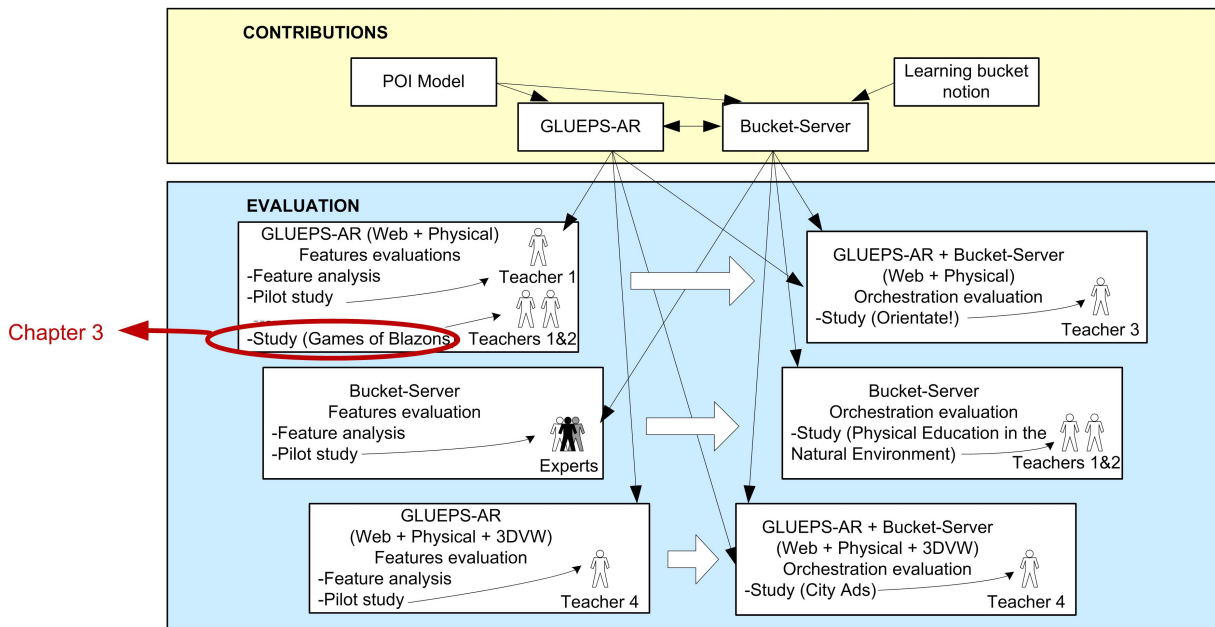

Figure 3.2: Evaluation works covered by Chapter 3.

To be submitted

Game of Blazons: Helping teachers conduct learning situations that integrate web tools and multiple types of augmented reality

Abstract: Several studies have long explored how to help teachers carry out learning situations involving Augmented Reality (AR), a technology that has shown several affordances for learning. However, these proposals tend to rely on specific types of AR, focus on specific types of spaces, and are generally disconnected from other technologies widely used in education, such as VLEs or Web 2.0 tools. These constraints limit the possible range of activities that can be conducted and their integration into the existing classroom practice. GLUEPS-AR is a system that can help overcome these limitations, aiding teachers in the creation and enactment of learning situations that may combine multiple types of AR with other common web tools. This paper presents an evaluation study conducted on Game of Blazons, a learning situation carried out by two university teachers using GLUEPS-AR, and framed within two days of outdoor activities in a village of Spain. Game of Blazons made use of multiple types of AR, Web 2.0 tools and augmented paper. The evaluation showed that GLUEPS-AR provided an affordable support to the participant teachers to integrate several activities that used multiple web and AR tools into a unique learning situation.

1 Introduction

An Augmented Reality (AR) system combines real and virtual objects in a physical environment, runs interactively and in real time, and aligns real and virtual objects with each other (Azuma et al., 2001). The use of AR has been explored extensively by the research community during the last 50 years (van Krevelen & Poelman, 2010). But only recently, the technological advances, especially in mobile devices such as tablets and smartphones, are making AR widely accessible (Papagiannakis, Singh, & Magnenat-Thalmann, 2008). AR has shown different affordances for learning. For instance, AR can enable ubiquitous, contextual, collaborative and situated learning; may promote learners' sense of immersion and immediacy; is able to enrich physical spaces with additional information (e.g., "making visible the invisible"); could bridge formal and informal learning; or enable learning from multiple perspectives (Dunleavy, Dede, & Mitchell, 2009; Sheehy, Ferguson, & Clough, 2014; Wu, Lee, Chang, & Liang, 2013). During the last years, there has been a renewed interest in researching the use of AR in education (Sheehy, et al., 2014; Wu, et al., 2013). Part of this interest focuses on how to help teachers conduct learning situations that make use of AR. The Technology Enhanced Learning (TEL) research community, under the umbrella of the "orchestration" metaphor (Prieto, Dlab, Gutiérrez, Abdulwahed, & Balid, 2011), has addressed the difficulties faced by teachers when carrying out learning situations supported by complex technological settings. Thus, several authors have explored some of these orchestration aspects, such as

how to help teachers create and enact learning situations that make use of AR (Dillenbourg & Jermann, 2010; Klopfer et al., 2011; Wu, et al., 2013). However, the approaches that explore the use of AR in education tend to rely on specific types of AR (e.g., markers or geolocation), and to augment specific types of spaces (e.g., physical environments or paper) (Cheng & Tsai, 2013; Prieto, Wen, Caballero, & Dillenbourg, 2014). Such specificity in the research proposals limits the available learning affordances to those of particular augmented spaces and types of AR (Cheng & Tsai, 2013; Prieto, et al., 2014). Another aspect important for the orchestration which some authors highlight is how to embed AR into existing classroom practice (Cuendet, Bonnard, Do-Lenh, & Dillenbourg, 2013; Prieto, et al., 2014). Learning effectiveness of AR activities depends on their integration into a heterogeneous set of activities, pedagogies and technologies at different levels (individual, group and class) (Prieto, et al., 2014). Nevertheless, several current research approaches propose AR solutions that are disconnected from technologies commonly used in education such as Virtual Learning Environments (VLEs, e.g., Moodle¹) (Keller, 2005) or Web 2.0 tools (e.g., Google Docs²) (Conole & Alevizou, 2010), thus hampering the integration of such AR systems in the everyday practice of many teachers and institutions. Some authors stress the range of applicability (i.e., the range of possible learning scenarios) as one of the factors to consider for supporting orchestration when designing educational technology (Niramitranon, Sharples, Greenhalgh, & Lin, 2010). Therefore, there is a need of AR systems that may support a wider range of applicability (Prieto, et al., 2014), and that do not preclude the integration of different types of AR and augmented spaces with other technologies commonly used in the classroom. The research question that we explore in this paper is *how technology can help teachers affordably create and enact authentic learning activities that may use different types of AR, different kinds of augmented spaces, and combine AR with other technologies commonly used by teachers.*

In this line, GLUEPS-AR (Muñoz-Cristóbal et al., 2014) is a system that can help teachers create and enact learning situations that may use multiple web and AR technologies. GLUEPS-AR can integrate multiple existing mobile AR clients (e.g., Junaio³) and several web technologies commonly used in education, such as VLEs and Web 2.0 tools. Since GLUEPS-AR is not restricted to specific AR systems, the learning situations deployed⁴ with GLUEPS-AR can make use of different clients implementing different types of AR and augmenting different kinds of spaces. The main features of GLUEPS-AR for its deployment affordability were evaluated in a pilot study (Muñoz-Cristóbal, et al., 2014), but without a real enactment with students. In addition, the support provided by GLUEPS-AR to orchestration was evaluated in a study with students (Muñoz-Cristóbal et al., 2015)⁵, although the use of AR was restricted to marker-based AR in physical environments. Thus, a new study is required to explore the GLUEPS-AR range of applicability, i.e., whether GLUEPS-AR can support learning activities that make use of multiple types of AR (eventually augmenting multiple types of learning spaces),

¹ <https://moodle.org>. Last access April 2015.

² <http://www.google.es/docs/about/>. Last access April 2015.

³ <http://www.junaio.com>. Last access April 2015.

⁴ Throughout this document, we refer with deployment to the setting up of the technological environment used during the enactment.

⁵ Such paper is already published, although it is included in the dissertation after this Chapter (it corresponds to Chapter 6, as explained in Chapter 1).

and that do not preclude the use of existing learning tools such as those based on common web technologies.

In order to explore the research question, GLUEPS-AR was used, in an evaluation study, to create and enact an authentic learning situation, named “Game of Blazons”, by the two teachers of the lecturing team of an undergraduate course for pre-service teachers on Physical Education in the Natural Environment. Game of Blazons demanded the use of marker-based AR and geolocation, the augmentation of physical environment and paper, and the integration of AR with Web 2.0 tools. Such evaluation study is the main contribution of this paper.

The structure of the rest of the document is the following. The next section outlines related approaches in the literature to use AR in education. Section 3 describes the GLUEPS-AR system, highlighting its features to support different types of AR and spaces, as well as to integrate AR with other tools common in education. Section 4 details the evaluation carried out of the support provided by GLUEPS-AR to conduct the Game of Blazons learning situation. Finally, the main conclusions obtained in the study are summarized in Section 5.

2 Related work

AR technologies can be classified into marker-based or markerless, depending on how the virtual and the real objects are aligned with each other (Cheng & Tsai, 2013; Pence, 2010)⁶. In marker-based AR, markers (also referred as tags or labels) are detected by AR devices and used as references to position the virtual artifacts. In markerless AR, the location of the AR device is recognized without using markers (e.g., using a GPS, a wireless network or sensing the physical environment). Both types of AR have been explored in the learning domain, and each one has shown different affordances for learning (Cheng & Tsai, 2013; Santos, Pérez-Sanagustín, Hernández-Leo, & Blat., 2012). For example, markerless AR is normally employed in outdoor activities with mobile devices, offers a good support in collaborative inquiry-based learning (Cheng & Tsai, 2013), and it does not require to prepare the physical setting previously to the activity, such as placing the markers (Santos, et al., 2012). On the other hand, marker-based AR may foster spatial ability, practical skills in laboratories, or conceptual understanding (Cheng & Tsai, 2013), and it is suitable when accuracy in the alignment between the student and some position or object is necessary (Santos, et al., 2012). The different types of AR have been used in multiple types of scenarios. Thus, several proposals have employed markerless AR based in geolocation, augmenting geographical locations with virtual content for creating games (Dunleavy, et al., 2009; Facer et al., 2004; Holden & Sykes, 2011; Klopfer, 2008; Klopfer & Squire, 2008; Squire & Jan, 2007; Ternier, Klemke, Kalz, van Ulzen, & Specht, 2012), field trips (Cook, 2011; Kamarainen et al., 2013), gymkhanas (Robles, Gonzales-Barahona, & Fernandez-Gonzales, 2011), assessed routes (Santos, Pérez-Sanagustín, Hernández-Leo, & Blat, 2011), and other kinds of learning situations (Billinghurst & Duenser, 2012; FitzGerald, 2013; Ibáñez, Maroto, García Rueda, Leony, & Delgado Kloos, 2012). Other

⁶ Although Pence (2010) and later Cheng and Tsai (2013) base the mentioned classification in the use of fiducial markers and visual see-through displays (see van Krevelen and Poelman, 2010, for details about the types of displays), the same classification can be extended to other kinds of markers and displays.

studies have employed marker-based AR using markers of different kinds for aligning real and virtual objects. Some markers store the information (a text, a URL, etc.) used to augment the physical objects or locations. For example, some studies use radio markers based on RFID/NFC or 2D barcodes such as QR codes, that contain information used to augment a physical space for learning art, sciences (Fernández-Panadero & Delgado Kloos, 2013), zoology (Rouillard & Laroussi, 2008), history (Kurti, Spikol, & Milrad, 2008; Sintoris et al., 2012), physical education (Horne, 2013) or for knowing the services and resources of a university campus (Pérez-Sanagustín, Martínez, & Delgado Kloos, 2012; Pérez-Sanagustín et al., 2011). In other cases, markers do not contain information, but are recognized and identified by the AR system, which associate them with virtual objects. That is the case of fiducial markers (Kato & Billinghurst, 1999), which are markers that can be recognized by an image processing module of the AR system. The AR system then tracks the 3D scene, detects the marker and carries out the actual combination of the physical space with virtual objects. Such markers can be of different shapes, such as circles, squares, or even complex images. Several approaches have used fiducial markers to superimpose virtual objects (e.g., text, 2D images or 3D models) to physical spaces for learning mathematics (Spikol & Eliasson, 2010), biology (Pérez-López, Contero, & Alcañiz, 2010), logistic (Cuendet, et al., 2013), art (Di Serio, Ibáñez, & Delgado Kloos, 2013), sciences (Echeverría et al., 2012; Enyedy, Danish, Delacruz, Kumar, & Gentile, 2011; Kerawalla, Luckin, Seljeflot, & Woolard, 2006; Salvador-Herranz, Pérez-López, Alcañiz, & Contero, 2011), physical education (Martín-Gutiérrez, 2011), etc.

In addition to augmenting physical environments (a classroom, the street, a natural environment, etc.), it is interesting the case of augmenting paper. Paper is an everyday physical object with some characteristics that make it very useful in education (Bonnard, Verma, Kaplan, & Dillenbourg, 2012; Luff et al., 2007): paper is easily handled and annotated; it is easy to carry around, to take home, classroom or outdoor, to pass from one student to another and to the teacher; it affords tiny shifts in position and orientation, and it is also flexible and mobile, thus enabling several kinds of activities; paper is also cheap, and it is present everywhere in multiple educational contexts. Due to the multiples affordances of paper for learning, several research proposals have explored the use of augmented paper in education during the last years (Prieto, et al., 2014). For instance, some of these works have augmented sheets or books for enriching them with 2D or 3D content, or for linking to additional material (Billinghurst & Duenser, 2012; Bonnard, et al., 2012; Laviolle & Hachet, 2012; Mackay, 1998; Martín-Gutiérrez et al., 2010; Prieto, et al., 2014; Wellner, 1993; Yuen, Yaoyuneyong, & Johnson, 2011).

All these mentioned research efforts illustrate the interest showed by the TEL community during the last years in the use of AR in education. However, there is a dearth of proposals allowing the use of different types of AR (Cheng & Tsai, 2013). This forces teachers to use multiple systems if they want to conduct activities taking advantage of the different affordances of each type of AR. Only some proposals enable the combined use of QR codes and geolocation (de-las-Heras-Quirós, Román-López, Calvo-Palomino, Gato, & Gato, 2010; Gagnon, 2010; Kaddouci, Peter, Vantroys, & Laporte, 2010; Stevense & van der Tak, 2010). However, these systems do not integrate AR with other technologies commonly used in education (e.g., VLEs, Web 2.0 tools, etc.). Also, they are designed for specific types of spaces (e.g., they are focused on indoor or outdoor physical spaces). Santos et al. (2012) explored

different types of AR (with geolocation, RFID/NFC tags and QR codes), but they used each type in a different study with different systems, which were not integrated with other technologies commonly used in education such as VLEs or Web 2.0 tools. In addition to this problems for augmenting physical environments, augmented paper is scarcely employed in authentic settings, and the existing solutions for its use in education are ad-hoc proposals, disconnected from other technologies already used by teachers in their practice, and with a limited range of applicability (Prieto, et al., 2014). The next section describes GLUEPS-AR, a system that tries to help teachers put into practice learning situations that integrate multiple types of AR with other web tools widely used in education.

3 GLUEPS-AR

GLUEPS-AR (Muñoz-Cristóbal, et al., 2014) is a system aimed to help teachers create and enact authentic learning situations that may involve multiple types of AR, different kinds of spaces, and several web tools widely used in education. GLUEPS-AR relies on an architecture based on adapters to integrate multiple systems of different types (see Muñoz-Cristóbal, et al., 2014, for details about the architecture). Thus, GLUEPS-AR may integrate multiple learning design authoring tools, multiple mobile AR clients, multiple VLEs and multiple Web 2.0 tools (see Figure 1 top left). This multi-to-multi approach enables teachers to design learning situations (Koper, 2005) using any of the multiple learning design authoring tools⁷ that GLUEPS-AR may integrate, such as WebCollage (Villasclaras-Fernández, Hernández-Leo, Asensio-Pérez, & Dimitriadis, 2013), edit2 (Sobreira & Tchounikine, 2012) or Pedagogical Pattern Collector (Laurillard et al., 2013). In these authoring tools, the teachers can define the different activities, participants, groups and learning resources (depending on the features of the tool used). After that, the teachers can use GLUEPS-AR to import the learning design and specify, using the GLUEPS-AR user interface (see Figure 1 top-right), characteristics that were not defined in the authoring tool (e.g., information regarding the different spaces involved, such as the positioning of the learning artifacts). GLUEPS-AR extends to physical spaces the architecture of its predecessor, GLUE!-PS (Prieto et al., 2013), focused on web spaces. Hence, the teachers can use GLUEPS-AR to deploy automatically such learning situations in different Ubiquitous Learning Environments (ULEs, Li, Zheng, Ogata, & Yano, 2004) which span web and physical spaces (see Figure 1 top-left). These ULEs may be composed of several AR systems, such as common mobile AR browsers (Grubert, Langlotz, & Grasset, 2011; e.g., Junaio, Layar⁸, etc.), as well as of multiple web systems widely used in education, such as VLEs (e.g., Moodle), or Web 2.0 tools (e.g., Google Docs or Picasa⁹). The integration of multiple mobile AR clients enables the support of different types of AR. More precisely, the current GLUEPS-AR prototype supports AR based in geolocation (markerless), as well as in QR codes and fiducial markers (marker-based). However, the GLUEPS-AR architecture is not restricted to these ones, and the prototype could be easily extended for supporting more types. Any learning artifact in an activity (e.g., a Google Docs document) can be positioned using any of the AR positioning types, and be reused in a subsequent activity using another AR type, or without using AR (e.g.,

⁷ E.g., see a list of learning design authoring tools in the Learning Design Grid website (<http://www.ld-grid.org/resources/tools>. Last access April 2015.).

⁸ <https://www.layar.com>. Last access April 2015.

⁹ <http://www.google.com/picasa/>. Last access April 2015.

accessing the Google Docs from Moodle). In the GLUEPS-AR user interface (see Figure 1 top-right), the teachers can also manage the learning situation and their resources and be aware of the students actions. This awareness is complemented with information about the location of students during the enactment of the learning situation, which is provided to teachers by means of AR browsers. In addition, aiming to help teachers use markers in different spaces, such as in augmented paper, the GLUEPS-AR user interface provides a final printable sheet with the compilation of the markers of a learning situation. It helps teachers use such markers at enactment time (by printing the sheet directly in order to cut out the markers, or by copying and pasting them in a document). GLUEPS-AR also automates the creation and deletion of web tool instances by means of integration adapters (Alario-Hoyos & Wilson, 2010) such as GLUE! (Alario-Hoyos et al., 2013), the one implemented in the prototype. In addition, GLUEPS-AR is designed to support collaborative learning, even if the authoring tool or the web and AR tools employed do not support it natively. Thus, by using the GLUEPS-AR user interface, a class may be structured in groups of students, and later on during the enactment, different groups may access different tools and resources in the same space position (e.g., in the same fiducial marker or the same geolocation). Figure 1 shows examples of the use of two different types of AR in two spaces in a learning situation: marker-based AR with markers augmenting paper, and markerless AR with a learning artifact geolocated in a physical environment. In both cases, AR enables the access to Web 2.0 artifacts from such physical spaces (not visible in the figure).

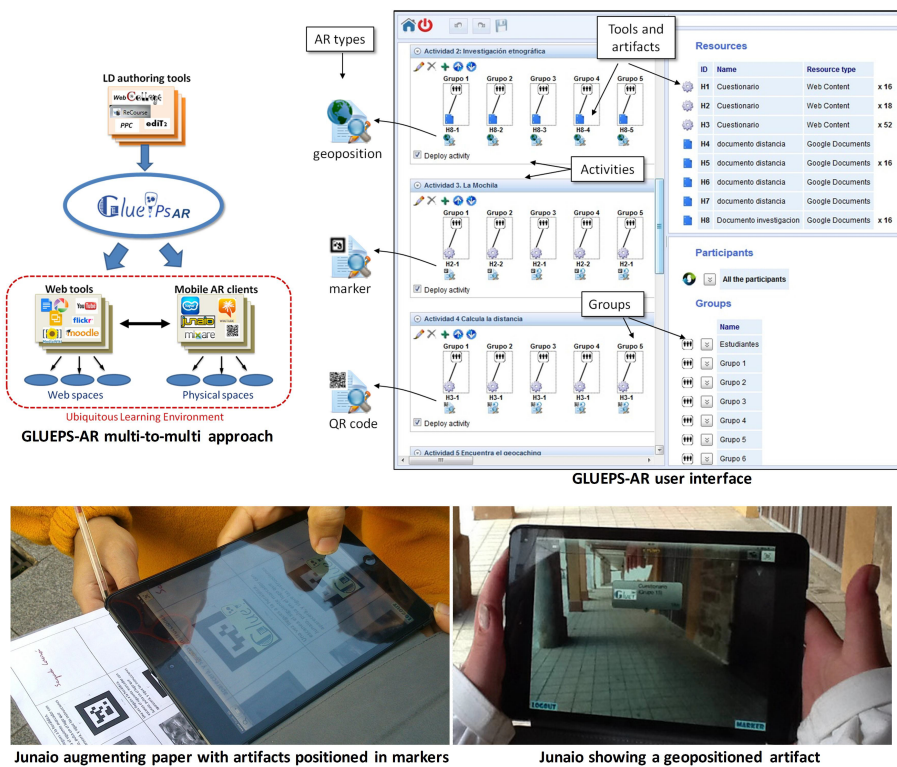

Figure 1. GLUEPS-AR multi-to-multi approach (top-left), GLUEPS-AR user interface (top-right), and Junaio user interface showing artifacts positioned in fiducial markers (bottom-left) and geolocated (bottom-right)

Table 1 shows the different GLUEPS-AR features that can aid teachers in the challenge of creating and enacting learning situations involving different types of AR, augmenting different types of spaces, and integrating AR activities into the existing classroom practice. As Table 1 illustrates, the GLUEPS-AR multi-to-multi approach is a key factor in such challenge, helping teachers create and combine multiple activities that may use different types of AR and web tools, extending thus the possible range of applicability with respect to alternative approaches. The next section describes the evaluation carried out to assess the support provided by GLUEPS-AR to this challenge.

Table 1. Specific GLUEPS-AR features to help overcome the challenge of using multiple types of AR, augment different spaces and integrate AR activities into the existing educational practice

Aspects of the challenge	GLUEPS-AR features	Current prototype implementation
Creation and enactment of learning situations that use AR	Helping create and deploy learning situations in different ULEs. Providing a user interface and runtime information to help manage the learning situations and be aware of the students' actions.	Integrates 3 authoring tools (WebCollage, edit2, PPC) and any other supporting IMS LD ¹⁰ level A; provides a user interface; provides AR user awareness.
Use of multiple types of AR and augmented spaces	Enabling the use of multiple AR systems, which may support different types of AR and may be suitable for augmenting different spaces.	Integrates 4 mobile AR clients (Junao, Layar, Mixare ¹¹ , any QR code reader); supports 3 types of AR (fiducial markers, QR codes, geolocation); provides a list of markers ready to be copied/pasted in paper.
Integration of AR with other activities of the existing educational practice	Enabling a seamless integration of AR systems with multiple web tools, such as VLEs or Web 2.0 tools.	Integrates 2 VLEs: Moodle and Mediawiki ¹² ; Integrates more than 20 third party tools and artifact types: Google Docs, Google Slides ¹³ , Picasa, several widgets, 3D models, etc.

4 Evaluation

We have carried out an evaluation to explore the research question that drives our work: *how can technology help teachers affordably create and enact authentic learning activities that may use different types of AR, different kinds of augmented spaces, and combine AR with other technologies commonly used by teachers?*

For the evaluation, we studied how a lecturing team, with the help of GLUEPS-AR, created and enacted a learning situation called "Game of Blazons" in October 2013. The lecturing team was composed of a main and an assistant teachers, with pedagogical background and teaching expertise of 22 and 1,5 years respectively. This section describes the learning situation carried out, as well as the evaluation method and results.

4.1 Game of Blazons

Game of Blazons is a learning situation that was created and enacted by the two teachers of an undergraduate course on Physical Education in the Natural Environment, corresponding to the last year (out of 4) of a Degree in Primary Education for pre-service teachers (University of

¹⁰ <http://www.imsglobal.org/learningdesign/>. Last access April 2015.

¹¹ <http://www.mixare.org>. Last access April 2015.

¹² <http://www.mediawiki.org>. Last access April 2015.

¹³ <http://www.google.com/slides/about/>. Last access April 2015.

Valladolid, Spain). The teachers were the main teacher of the course and an assistant teacher, and the learning situation was enacted with a class of 47 students. The teachers used the WebCollage authoring tool to create a sequence of collaborative learning activities, indicating also the resources to use and the configuration of groups of students. Then, they imported automatically such design into GLUEPS-AR. Using the GLUEPS-AR user interface, they set up the design (creating and configuring the different tool instances, defining the positioning type and the specific position of the different learning artifacts, etc.). Finally, they deployed with a single click the design into a ULE composed of Moodle, some Web 2.0 tools, the Junaio mobile AR client, and any common QR code reader (although Moodle was used only in sessions previous to Game of Blazons).

Game of Blazons was carried out in Cervera de Pisuerga, a small village situated in a mountainous area in northern Spain, which was a thriving town in the Medieval times. It was framed within activities spanning two days of work with the students in the village and its surroundings. Such work was focused on acquiring skills for preparing physical education activities in the natural environment for Primary school pupils (e.g., camping activities). Those two days also included several activities apart of Game of Blazons (ethnographic, cultural and social activities, trekking, orienteering, canoeing, etc.). Moreover, the multiple activities carried out in situ were preceded by a lecture in the classroom, and by online work using Moodle. During Game of Blazons, the use of existing technologies was required because the teachers, in addition to innovating and enriching the learning experience by using technology, aimed to show the students a possible range of applications they could use in the Primary school. The enactment of the learning situation was led by the assistant teacher, who explained what to do to the different groups of students.

Game of Blazons was conducted in groups of three students (and one group of two students since they were 47). The aim of the learning situation was to find, using orienteering skills, 7 stone blazons chiseled in the walls of different village's buildings¹⁴, and perform close to each blazon a specific activity, delivered to the students by means of AR. Such activities were focused on acquiring and reinforcing knowledge and skills about the natural, cultural and ethnographic environment, as well as about physical education in the natural environment. Also, the students had to find out the names of the blazons on their own (e.g., searching in the Web, or interacting with locals). The time assigned to each group to complete the situation was 1,5 hours. Each group received:

- A tablet with 3G connection and with the following installed apps: the Junaio AR browser, a QR code scanner¹⁵, a geocaching¹⁶ app¹⁷, and a drawing app¹⁸ with the map of the Village. The students could also use their own mobile phones (the tablets

¹⁴ Cervera de Pisuerga preserves several stone blazons in its buildings since the Middle Ages.

¹⁵ <http://www.neoreader.com>. Last access April 2015.

¹⁶ Geocaching is a public gymkhana based in GPS coordinates. People hide little "treasures" (called geocaches), and publish their position in a website (there are various geocaching communities, such as <https://www.geocaching.com>). The person who finds a treasure has to write her name in a paper included in the treasure, and optionally, replace an object of the treasure with another object.

¹⁷ Lookin4Cache (<http://www.looking4cache.com>) in iOS devices and c:geo (<http://www.cgeo.org>) in android ones. Last access April 2015.

¹⁸ LINE Brush, available at <http://line.me/es/family-apps>. Last access April 2015.

ensured that each group was provided with a tested device, with all the required apps and resources installed, and good internet connectivity).

- A paper sheet (see Figure 2 and bottom-left of Figure 1) with the description of the learning situation and pictures of the seven blazons (without indicating their locations). In each blazon, the sheet included: an empty field to fill up with the name of the blazon; an empty field to indicate the marker number in the paper map corresponding to the blazon; instructions to perform the activity.
- An orienteering paper map of the village (see Figure 3), indicating the start and finish points, and the location of the 7 blazons.





Marker No.	Blazon	Activity	Blazon name
		You will see with Junaio the activity geolocated once you get close to the blazon	
		Once you get the blazon, scan the following marker with Junaio, click in the logo that will appear, and follow the instructions 	
		Scan the QR code that you will find close to the location of the blazon	

Figure 2. Partial view of the activity paper sheet (translated to english) with the three possible instructions to follow in a blazon

Figure 2 shows a piece of the paper sheet (the same for all the groups), with the three possible procedures to follow when a blazon was located. The teachers decided to use the three types of AR (geolocation, QR code located close to a blazon, fiducial marker in the paper sheet) in order to illustrate to the students the different technological possibilities for augmenting physical spaces with virtual learning artifacts, as well as their advantages and disadvantages. The geolocated artifacts were configured to be visible with AR when the students were less than 20 meters away from the blazons.

In order to foster the autonomous work of the different groups, each group had to start the race in a different blazon, and there were only 4 groups conducting Game of Blazons simultaneously in each turn. Once a group found a blazon, they had to identify it in the paper sheet, indicating the corresponding marker number of the orienteering map, finding out the blazon name (usually interacting with locals) and performing the indicated activity. The activities that the students had to conduct at the blazons were of the following types:

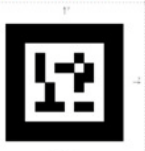
- Answering a web-based questionnaire (created with Google Forms¹⁹) to reinforce and assess topics that had been: lectured in the classroom, worked in groups (both face-to-face and using Moodle), and experienced during the two days in the village (e.g., related to trekking, hiking, etc.).
- Conducting a geocaching activity. The identifier of a specific geocache (the geocaching “treasure”) was given to the students in a Google Docs document, and they had to find the geocache using the geocaching app installed in the tablet (or alternatively, a geocaching app installed in their mobile phone).
- A name of something popular in the village was given in a Google Docs document, and the students had to interact with the village’s inhabitants to find out who or what it was. The students had to write the answer in the Google Docs document.



Figure 3. Game of Blazons: Orienteering map of Cervera de Pisuerga and snapshots of the learning situation

The fiducial markers and geolocations pointed to different activities when accessed by different groups performing the race simultaneously. For example, in the same blazon, different groups accessed different questionnaires, had to find different geocaches, or had to find out information regarding different characters. Once the activities in all the blazons were completed, or when the time limit expired, the students had to go to the finish point and draw the path they had followed, in the village map loaded in the drawing app of the tablet. Figure 3 shows the orienteering map they used and snapshots of the learning situation, illustrating the different types of activities that the students carried out.

¹⁹ <http://www.google.com/forms/about/>. Last access April 2015.

4.2 Method

We have followed the Evaluand-oriented Responsive Evaluation Model (EREM) (Jorrín-Abellán & Stake, 2009) to design and carry out the evaluation. The EREM is an evaluation framework inspired in the responsive evaluation approach (Stake, 2004), and framed within the interpretive research paradigm (Orlikowski & Baroudi, 1991). This kind of evaluation does not pursue statistical significant results, but it is aimed to the deep understanding of the phenomenon under study, in this case by means of the use of GLUEPS-AR by teachers in an authentic learning situation.

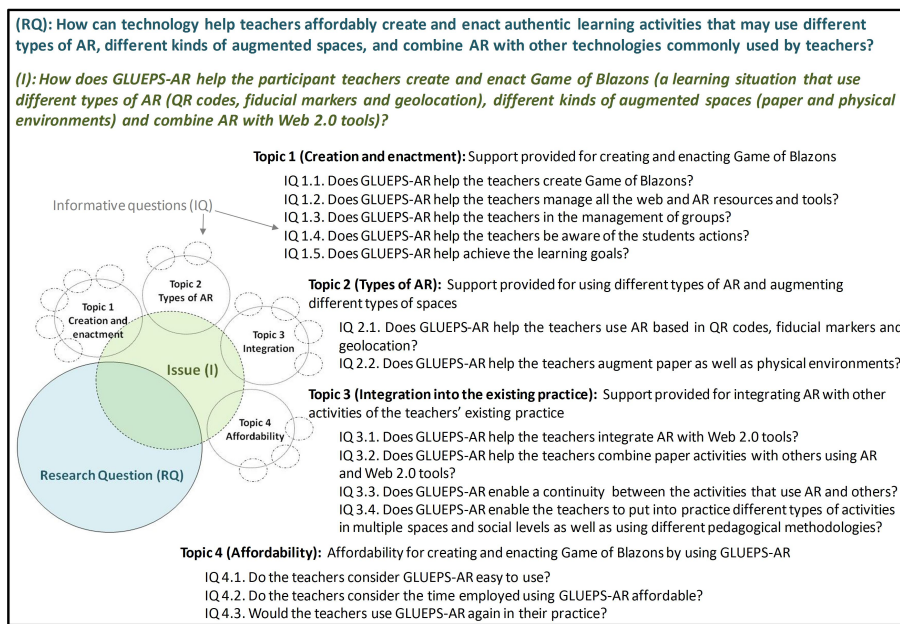

Figure 4. Anticipatory data reduction showing research question (RQ), issue (I), topics and informative questions (IQ)

In order to help illuminate the research question that we posed, we conducted an anticipatory data reduction process (Miles & Huberman, 1994) during the evaluation design (see Figure 4). Thus, we defined an issue (*how does GLUEPS-AR help the participant teachers create and enact Game of Blazons?*) as the main conceptual organizer of the evaluation, dividing it into four topics to help understand the issue: *the support provided for creating and enacting Game of Blazons* (topic 1); *the support provided for using different types of AR and augmenting different types of spaces* (topic 2); *the support provided for integrating AR with other activities of the teachers' existing practice* (topic 3); and *the affordability for creating and enacting Game of Blazons* (topic 4). In the same fashion, each topic was explored through different informative questions to help illuminate the topics. This schema of research question-issue-topics-informative questions guided the data gathering and analysis processes.

During the evaluation we used multiple data gathering techniques and sources (see Table 2). We carried out different strategies to ensure the confirmability and credibility of the results, as well as to guarantee the quality and rigor of the evaluation (Guba, 1981). Some of such

strategies were triangulation of data sources, researchers and methods, as well as member checking, receiving feedback from the involved teachers about the data and interpretations. We employed the NVivo²⁰ software for the analysis of the gathered data.

Figure 5 illustrates the evaluation process, which has been divided into happenings (evaluation events). The first happening (H1) consisted in the preparation steps. It involved: a) two testing sessions (one with each teacher), where both teachers tested GLUEPS-AR with the help of the research team; and b) a conceptual design phase, including a preliminary visit to the village. In a second happening (H2), the teachers used the WebCollage authoring tool and GLUEPS-AR to author the learning situation and deploy it in the web and AR tools. During the session, the main teacher led the process, using WebCollage and GLUEPS-AR, while the assisting teacher helped him (e.g., creating the questionnaires). The third happening (H3) consisted in the enactment of Game of Blazons with 47 students in Cervera de Pisuerga. Finally (H4), we recorded an evaluation meeting conducted just after finishing Game of Blazons, in which the teachers reflected about the result of the learning situation. Later on, feedback from them was retrieved using a web-based questionnaire followed by interviews.

Table 2. Summary of the data gathering techniques employed and their purpose in the evaluation

Technique	Description	Purpose
Collection of participant-generated artifacts [Art]	Collection of a diverse set of electronic artifacts generated by the participants. Types of data collected include emails with teachers, learning designs and products and educational materials.	Registering the learning design process, as well as the use of the systems and tools by the participants. Being aware of the participants' asynchronous activities. Complementing the observations with information of the generated learning artifacts.
Screen recording [Screen]	Recording, using specialized software, of the actions performed in (screen recording) and out (video and audio) the computer by the participants during different evaluation happenings.	Understanding the design and deployment processes, and measuring the amount of time that these processes require.
Observation [Obs]	Naturalistic, semi-structured observations during different evaluation happenings. The data collected were audio/video recordings, pictures and observation notes.	Registering the actions, impressions and other emergent issues of the participants during different evaluation happenings.
Questionnaire [Quest]	Qualitative, web-based exploratory questionnaire, designed in an iterative review process by the research team. Composed of open-ended and closed items (6-point scale [1=strongly disagree, 2=disagree, 3=somewhat disagree, 4=somewhat agree, 5=agree, 6=strongly agree] + Don't know/No answer).	Collecting the opinions of the participants about a wide range of matters.
Interview [Int]	Qualitative, semi-structured, face-to-face, one-to-one conversation with the teachers (recorded and transcribed).	Capturing the opinions of the teachers in depth, after an initial analysis of other data sources (e.g., observation data, questionnaire answers, etc.).

²⁰ <http://www.qsrinternational.com>. Last access April 2015.

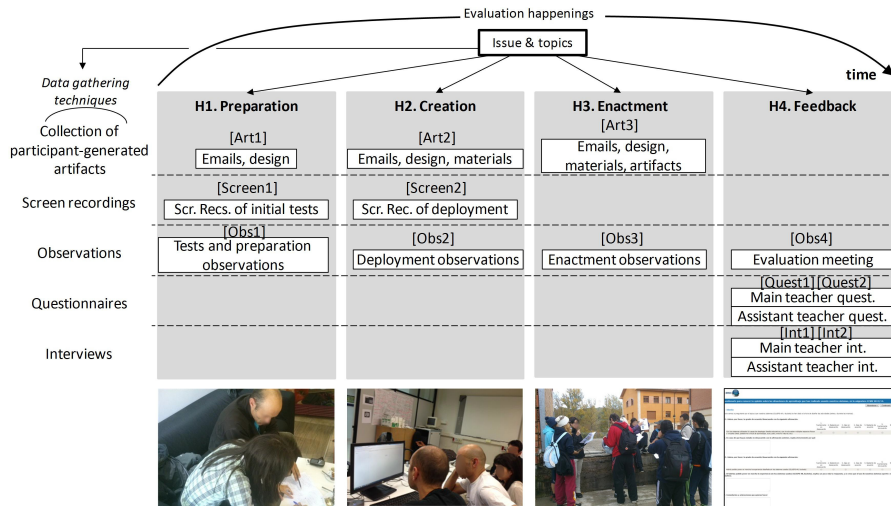

Figure 5. Evaluation happenings and data gathering techniques used during the evaluation, as well as snapshots of the happenings

4.3 Results

This section describes the main results obtained during the evaluation process, structured using the topics of the anticipatory data reduction schema (see Figure 4). Each result is supported with different excerpts of evidence gathered in the evaluation. Due to space restrictions and for a better readability, only a selection of excerpts is presented. Table 3 summarizes the main findings obtained in the evaluation, indicating (using the same labels as in Figure 5) the data sources that support the findings. This table exemplifies the triangulation process followed in the study.

Table 3. Main findings of the evaluation process

Topic	Findings	Supporting Data
1. Creation and enactment	GLUEPS-AR helped the teachers create and enact the Game of Blazons learning situation, as well as aided in engaging the students and achieving the learning goals.	Art1-3, Int1-2, Obs1-4, Quest1-2, Screen1-2
2. Types of AR	GLUEPS-AR helped the teachers use different types of AR (geolocation, fiducial markers and QR codes) and augment different types of spaces (physical environment and paper).	Art1-3, Int1, Obs1-4, Quest1-2, Screen2
3. Integration into the existing practice	GLUEPS-AR helped the teachers integrate the use of AR with other activities based on paper and pencil, Web 2.0 tools and mobile apps, achieving continuity between the different activities and tools.	Art1-3, Int1-2, Obs1-4, Quest1-2, Screen1-2
4. Affordability	The use of GLUEPS-AR was affordable for the teachers and they would use it in their educational practice. However, it required an initial training and some practice. Also the use of an additional authoring tool added extra complexity and made the process longer.	Art1, Int1-2, Obs1-4, Quest1-2, Screen1-2

4.3.1 Topic 1. Creation and enactment

The evidence gathered during the evaluation indicates that **GLUEPS-AR helped the teachers create and enact the Game of Blazons learning situation, as well as aided in engaging the students and achieving the learning goals.** GLUEPS-AR helped the teachers create Game of Blazons by enabling them to use an existing learning design authoring tool (WebCollage) and deploy the created design in existing mobile AR clients (Junaio and any common QR code reader), a VLE (Moodle) and Web 2.0 tools (Google Docs and Google Forms) (see, e.g., Table 4 as well as [Quest1-2]^A and [Screen2] in Table 5). The teachers' process of creating and conceptualizing the design was iterative, and such design was not completely finished until the deployment session in which the technological resources were set up (two days before the enactment) (see, e.g., [Art1] in Table 5). GLUEPS-AR also helped the teachers manage the different learning tools and artifacts (see Table 4) by automating the creation of tool instances and by organizing the resources in a control panel: the GLUEPS-AR user interface (see, e.g., [Int2] and [Quest1-2]^B in Table 5). With respect to this aspect, a negative point was that the GLUEPS-AR prototype employed by the teachers did not implement a Google Forms adapter, which implied that questionnaires had to be created manually, and included in GLUEPS-AR using their URLs. Regarding the management of groups, GLUEPS-AR helped use collaborative learning, enabling the teachers to configure groups of students, and allowing different groups access different artifacts in the same marker or geoposition (see, e.g., [Int2] and [Obs4]^C in Table 5). Nevertheless, due to the large number of students and activities, the teachers preferred to carry out non-complex collaborative activities. Another interesting aspect was that despite most of the groups used mainly the tablets provided by the evaluation team (which favored the success of the learning situation by avoiding burdening teachers with the multiple potential issues that could arise in the students' own devices), several students used also their mobile phones. Such use of their own device was promoted by the teachers in order to help transfer the students' learning to other formal and informal contexts. The use of tablets also restricted the number of students to three per group, although such number adjusted well to the teachers' aims (see, e.g., [Obs4]^C in Table 5). GLUEPS-AR also allowed the teachers to monitor with Junaio the location of the students during the enactment (see in Figure 6 a screenshot taken during the enactment), but the teachers had not enough time to use such feature continuously during the learning situation, and they just used it sporadically with the mobile device of a member of the evaluation team (see, e.g., [Obs3] and [Obs4]^A in Table 5). The evaluation showed that such awareness feature could be enhanced with a map view to be used after the end of the activities, including the registry of the work performed by the students, indicating times and locations. GLUEPS-AR already stored such information, but it was not provided to the teachers nor included in the user interface. The teachers recognized that GLUEPS-AR helped achieve the learning goals, while engaging and motivating the students (see, e.g., [Quest1-2]^C and [Obs4]^B in Table 5. Table 5 shows some selected excerpts of evidence that illustrate these findings.

Table 4. Activities and artifacts created using GLUEPS-AR in Game of Blazons, indicating in each activity the number of groups and artifacts, the tool type, the AR type and the kind of augmented space.

Activity	No. groups	No. web artifacts	Web tool	AR type for delivery to students	Augmented space
1. Group management	16	2	Google Forms	Fiducial marker	Paper
2. Ethnographic inquiry	16	16	Google Docs	Geoposition	Physical environment

4.3.2 Topic 2. Types of AR

Regarding the types of AR supported, the main teacher wanted to use all the possible options of AR, in order to teach the students the different technological possibilities to augment physical spaces (see, e.g., [Screen2]^{C,D} in Table 6). The evaluation suggests that **GLUEPS-AR helped the teachers use different types of AR and augment different types of spaces** (see Table 4). GLUEPS-AR enabled the teachers to include in their design AR based in QR codes, fiducial markers and geolocation. GLUEPS-AR also allowed the teachers and the students to use such types of AR during the enactment by means of existing mobile AR clients such as Junaio and Neoreader (see, e.g., [Obs3]^A, [Quest1-2] and [Screen2]^D in Table 6). In addition, GLUEPS-AR helped the teachers use AR to augment physical environments and paper. Thus, a paper sheet was an instrument that enabled traditional work (reading, writing, sharing it, etc.), as well as to augment digitally both the sheet and stone blazons (see, e.g., [Obs3]^B and [Screen2]^A in Table 6). In order to facilitate the handling of markers (e.g., cut them out or copy and paste them in documents), the GLUEPS-AR user interface provided a list of the markers used in the learning situation (QR codes and fiducial markers) (see, e.g., [Screen2]^B in Table 6). The different types of AR showed different affordances. Thus, geolocation and fiducial markers enabled teachers to provide different artifacts to different groups in the same geolocation or marker. Such types of AR also saved time in the preparation of the learning situation in the village, due to the fact that only two QR codes had to be placed and removed in situ (which, in addition, had to be left 5 hours in such locations). On the other hand, the QR codes allowed a higher precision for locating markers, which was important in Game of Blazons for training orienteering skills (a geolocated artifact was configured by the teacher to be visible using AR when the students were less than 20 meters away from the blazon). Also, using fiducial markers in the paper sheet enabled teachers to reuse the paper template by giving all the groups a copy of the same paper sheet. Moreover, the sheet could be reused in subsequent years, since the virtual object associated to the markers could be easily changed in subsequent editions of the course. Finally, the utilization of different types of AR facilitated the remote creation of the learning situation, being only necessary to know beforehand the exact position of some of the blazons (the geolocated ones), and enabling last-time remote decisions (see, e.g., [Art1], [Obs2] and [Screen2]^D in Table 6).

A potential GLUEPS-AR improvement was identified during the evaluation, due to a problem in the format of the geographical coordinates. While GLUEPS-AR used decimal coordinates (the Google Maps format), the main teacher's GPS used UTM coordinates. This generated difficulties and delays in the deployment process for converting the geographical coordinates that the teacher gathered in situ when preparing the learning situation to the GLUEPS-AR format. Also, during the evaluation we detected that the combination of augmented paper with geolocation could be interesting, for instance, for enabling the access to the virtual artifact only when being close to a specific location. Table 6 shows a selection of excerpts of evidence that illustrates the aforementioned findings.

Table 6. Selected excerpts of evidence related to the Topic 2 (types of AR)

Data source	Excerpts
[Art1]	[Mail from main teacher] (...) the sheets they would carry in the activity to associate the real blazon with the one of the picture and scan the corresponding QR. [Answer from assistance teacher] At the end you mention that with QR code. Since finally they will carry a tablet... Do we geoposition them

	without QR? On the downside, we lose precision.
[Obs2]	The main teacher and a member of the evaluation team discuss about the procedure for using QR codes in the game of blazons. The idea is that the students need to get to the blazons to answer the questions.
[Obs3]	^A In each blazon, the possible activity to carry out is: to scan a QR code they will find close to the blazon and follow the instructions (2 QR codes), to scan with Junaio a marker that appears in the activity sheet next to the blazon's picture and follow the instructions (3 markers), to search with Junaio a geopositioned tool close to the blazon and follow the instructions (2 geositions) ^B The assistant teacher explains the activity without [giving them] the tablets, distributing the activity sheet (a laminated one, in case it rains, and another not laminated, to enable them to write on it).
[Quest1-2]	To the assertion "I think that GLUEPS-AR allows to take advantage of the geopositioning and the detection of markers that the mobile devices implement" both, the main and the assistant teachers answered 6, "Strongly agree".
[Screen2]	^A The main teacher explains how the students would use the sheet with the blazons (if there is a marker, they scan it, if there isn't, they know that it is geositioned). ^B (...) A member of the evaluation team shows to the main teacher the GLUEPS-AR button to obtain a list with all the markers and QRs used. ^C The main teacher wants to geosition also artifacts He says that aimed to [improve] the student's experience he wants to try the maximum number of things. One is to arrive and see it without scanning anything. Another one is to arrive and scan the paper (...). ^D (...) It is just to include variety. The objective is to include variety. I mean, where there aren't a lot of nearby blazons (...) we put Junaio [geositioned], and they do it with Junaio, and in addition we don't need to put a physical thing in a place, that, if we would have to put it, it would require work, and it's ugly, because it's going to be there 5 hours. But if you put it in a paper, which doesn't make ugly an environment, the people say "I'm going to scan" and you include a little of variety.

4.3.3 Topic 3. Integration into the existing practice

In this topic we explored how AR is integrated with other activities of the teachers' practice. The evaluation showed that **GLUEPS-AR helped the teachers integrate the use of AR with other activities based on paper and pencil, Web 2.0 tools and mobile apps, achieving continuity between the different activities and tools.** GLUEPS-AR enabled the teachers to associate different Web 2.0 tools (Google Docs and Google Forms) to different AR types (see Table 4). This association enabled the access, using AR, to Web 2.0 tool instances positioned in geolocations and QR codes placed close to stone blazons, which allowed teachers to know that the students had reached the blazons, and to enrich the blazons with learning contents (important aspects in orienteering activities). GLUEPS-AR also enabled the access to Web 2.0 tool instances positioned in fiducial markers included in the activity paper sheet (see, e.g., [Obs2], [Obs3]^{B,C} in Table 7). Thus, some activities conducted with the paper map and the paper sheet (orienteering, identifying blazons), were combined with other activities carried out using Web 2.0 tools and mobile apps (geocaching, drawing the followed track, ethnographic inquiry, and questionnaires related to topics lectured in the classroom and experienced during the two days in the village) (see, e.g., [Obs3]^{B,C} in Table 7). The teachers highlighted the GLUEPS-AR aid to the achievement of continuity between these activities (see, e.g., [Quest1-2]^E in Table 7). The use of AR was an important factor to attain the connection of the different activities and tools. GLUEPS-AR also enabled the teachers to integrate the AR activities with a VLE such as Moodle (see, e.g., [Int2] and [Screen1] in Table 7). The paper sheet acted as a script for the students, guiding them, together with the orienteering map, over the different locations and activities (see, e.g., [Obs3]^A in Table 7). Apart from the activities carried out in Game of Blazons, the teachers recognized that GLUEPS-AR may enable the carrying out of

several other types of activities in multiple spaces and social levels (individual, group, class), as well as using different pedagogical methodologies (see, e.g., [Int2] and [Quest1-2]^{A,B,C,D} in Table 7). However, although they believed in the GLUEPS-AR affordances for such range of applicability, they acknowledged that they would need to conduct more learning situations to confirm it (see, e.g., [Obs4]^A in Table 7). During the study, the teachers showed a major concern in being able to take advantage of the possibilities of technology for enriching learning in ULEs, without losing the essence of conducting learning activities in nature. All in all, the teachers were happy with the result of Game of Blazons and its connection of different pedagogical dimensions, and they perceived that the scenario would be easily replicable in other contexts (see, e.g., [Obs4]^B in Table 7). They also recognized that the technological setting deployed with GLUEPS-AR fitted very well with the contents of the course. However, they would need more time to reflect about the potential of GLUEPS-AR to create more complex, adjusted and significant pedagogical scenarios, because the rhythm of the course was very fast and they were very short of time to prepare Game of Blazons and reflect about it (see, e.g., [Int1] in Table 7). Table 7 shows a selection of excerpts that illustrate these findings.

Table 7. Selected excerpts of evidence related to the Topic 3 (integration into the existing practice)

Data source	Excerpts
[Int1]	"What I need is sitting down and saying: now I already know this resource, this is what I want to do, I'm going to try to do it" (...).
[Int2]	To a question regarding if GLUEPS-AR enables the carrying out of activities in different spaces, the assistant teacher answered "Yes, in different technological spaces, as well as, if you want to use Moodle, a wiki, etc."
[Obs2]	There is a long discussion to decide whether to create 16 questionnaires with Google Forms or to do the activity with Google Docs.
[Obs3]	^A The groups of students receive a paper sheet with the description of the activity, a tablet and a Cervera's orienteering map. They have to find 7 blazons. ^B In a new blazon, they have to investigate who is a character indicated in a geopositioned Google Docs. ^C They arrive at a blazon corresponding to junaio marker, and everything works fine. One of them seems to be a little distracted, but when the questionnaire appears, all of them answer it together.
[Obs4]	^A (...) We have to see how we can use it. For me it is clear [that I want to use it], and I like it, and I want to use it, but it is still difficult for me to propose more educational applications powerful-powerful-powerful. But, ok, it is a matter of time. ^B (...) It combines skills and knowledge of several types. Historic, observation, cultural heritage, augmented reality, orienting oneself in the time and space, ... I think it is an activity with a lot of possibilities, and it is super-replicable, for instance in Valladolid city, (...). Replicable from millions of points of view. Museums, sculptures, libraries, games, etc. And very transferable to children.
[Screen1]	The assistant teacher clicks in "deploy". The design is deployed into Moodle.
[Quest1-2]	^A To the assertion "I think that GLUEPS-AR may allow teachers to put into practice a wide range of learning activities" both, main and assistant teachers answered 6, "Strongly agree". ^B To the assertion "I think that GLUEPS-AR may allow to put into practice learning situations in several social levels (individual, group, class)" both, main and assistant teachers answered 6, "Strongly agree". ^C To the assertion "I consider that GLUEPS-AR may allow to use multiple pedagogical approaches, such as collaborative, non-collaborative, game-based learning, project-based learning, etc." the main teacher answered 4, "Somewhat agree" and the assistant teacher 5, "Agree". Also, the main teacher clarified that "In the cases that I answered 4 it was because I haven't corroborated it totally". ^D To the assertion "I think that GLUEPS-AR may allow to put into practice learning activities in different spaces (web, VLE, classroom, natural environment, etc.)" the main teacher answered 5, "Agree" and the assistant teacher 6, "Strongly agree".

^E To the assertion “GLUEPS-AR may enable continuity between the activities conducted in the different physical and virtual spaces (classroom, natural environment, web tools, Moodle, etc.)” both, main and assistant teachers answered 6, “Strongly agree”.

4.3.4 Topic 4. Affordability

In this topic, we explored the affordability for the teachers to put into practice Game of Blazons using GLUEPS-AR. The teachers did not consider GLUEPS-AR easy to use. However, they assessed its use as **affordable with an initial training and a little of practice** (see, e.g., [Int1]^B, [Int2]^A, [Quest1-2]^A, [Obs1] and [Screen1] in Table 9). In addition to this initial training, the teachers considered that it would be necessary to raise awareness among some teachers about the possibilities of the tool and the benefits that it could provide in the learning process of their students, to convince them to use it (see, e.g., [Int1]^{A,B} and [Int2]^B in Table 9). **Also, the additional use of an authoring tool (WebCollage) introduced extra complexity** (see, e.g., [Int2]^C in Table 9) and caused some problems (e.g., incoherencies between the learning situation in the authoring tool and in GLUEPS-AR, due to errors or modifications of the design). The teachers considered the time required to deploy Game of Blazons using GLUEPS-AR (see Table 8) long. Also, they judged such time as affordable and they acknowledged that it would be reduced with the practice (see, e.g., [Quest1-2]^C in Table 9). This time could be also severely reduced by automating multiple repetitive operations that had to be performed in the GLUEPS-AR user interface used (see, e.g., [Screen2] in Table 9). All in all, **the teachers recognized that they would use again GLUEPS-AR in their practice**, without saturating the course with technological activities (see, e.g., [Quest1-2]^B in Table 9). The main teacher acknowledged that he would like to involve the students in the preparation of the activities. However, the GLUEPS-AR system has a limited support about what the students are able to do, since all the resources and tools are pre-defined by the teachers.

During the enactment of Game of Blazons, we had several minor problems related to the technology that were easily solved with the help of the evaluation team or the assistant teacher (sometimes checking with an evaluator by phone). Some of those problems were: tablets not configured to allow Junaio access the geolocation of the tablet; some errors in Junaio that required restart the app; a QR code placed in a curved surface that made difficult the scanning; some initial difficulties for the students to choose the correct application (Junaio/neoreader) or the correct mode inside Junaio (there were different modes to see marker based and geoposition based AR); a Google Docs requirement for mobile devices to authenticate to access public shared documents; and the necessity of loading the tablets’ batteries during the lunch time (see, e.g., [Obs3] in Table 9). Table 9 shows some selected excerpts of evidence gathered during the evaluation, which can illustrate the mentioned findings.

Table 8. Time devoted by the teachers in the different deployments involved in the study

Deployment	Actor	Time		
		WebCollage	GLUEPS-AR	Total
Test design 1	Main teacher		15 min	15 min
Test design 2	Assistant teacher	23 min	10 min	33 min
Game of Blazons	Main teacher	1 h 30 min	2 h 48 min*	3 h 18 min*

* Including 10 min of repetitive operations performed by a member of the evaluation team

Table 9. Selected excerpts of evidence related to the Topic 4 (affordability)

Data source	Excerpts
[Int1]	^A "(...) the problems to implement this are the available time, or the difficulty, or the skills that each teacher has with this kind of things". ^B [asked about if GLUEPS-AR is easy to use] "I go back to the training. To the training, and to the raising of awareness"
[Int2]	^A "With respect to the GLUEPS-AR [user interface], I haven't used it a lot, and due to it, maybe it seems to be more difficult to me. But I saw with the main teacher that, in a moment, once you got it, it is the same design, so you just copy 20 times and you have it, it is not complicated. Then, you deploy it and here it goes". ^B "At the beginning, it is going to be super-rare for the teachers. And afterwards, it depends on the technological competence of each teacher". ^C "If I have to start with WebCollage, I think that the process is too long".
[Quest1-2]	^A To the assertion "I think that GLUEPS-AR is easy to use for non-ICT-expert teachers", the main teacher answered 3, "Somewhat disagree", and the assistant teacher answered 2, "Disagree". ^B To the assertion "I would use GLUEPS-AR in my educational practice", the main teacher answered 5, "Agree", and the assistant teacher answered 4, "Somewhat agree". ^C To the assertion "I think that the time devoted to the deployment using GLUEPS-AR was affordable", the main teacher answered 4, "Somewhat agree" and the assistant teacher answered "Don't know/No answer". The main teacher specified that "Maybe with more training in GLUEPS-AR, which we have used very little, my answer would be different".
[Obs1]	[Main teacher after using GLUEPS-AR] Yes, I see this part very easy.
[Obs3]	Another group arrives. They say that Junaio doesn't work. I look at it, and it is because instead of being in the correct Junaio channel, they are connected to a Chinese one. I tell them how to detect it and solve it.
[Screen1]	[Assistant teacher] No, it is not complicated, but there are some things that you have to know (...) what is destined to the teacher and what to the student (...) and also, to understand all the terms (...), such as the multiple positioning types... but I think that it is easy to use.
[Screen2]	The main teacher is reusing a tool instance in the even groups. At a given time, he asks if he has to do it in the even or in the odd groups. It seems that the repetitive operations bore him.

5 Conclusions

Game of Blazons is a learning situation that was carried out by two teachers of a course on Physical Education in the Natural Environment for pre-service teachers. Such situation involved the use of different types of AR, such as QR codes and geoposition, which augmented stone blazons chiseled in the houses of a medieval Spanish village, as well as fiducial markers, which augmented a paper sheet used as a script of the learning situation. Game of Blazons included the use of Web 2.0 tools, mobiles apps and paper and pencil. The evidence gathered during the evaluation shows that GLUEPS-AR provided an affordable support to the teachers for creating and enacting Game of Blazons. The evidence suggests also that GLUEPS-AR could help teachers put into practice other different learning situations that use multiple types of AR, augment physical environments or paper, and integrate AR with other tools commonly used in education, such as VLEs and Web 2.0 tools. Thus, the GLUEPS-AR approach could be a more general alternative to other proposals for using AR in education that focus on specific technologies, activities or pedagogies. On the other hand, although such more general approach could extend the possible range of applicability, it could also be less suitable for specific scenarios or purposes, where an ad-hoc solution could be more appropriate.

With respect to the use of authoring tools, the evaluation showed that although the use of WebCollage and GLUEPS-AR enabled the teachers to create Game of Blazons, those two tools

added a significant complexity and effort to the design process. In some cases, the complexity of the learning situation might be worth the effort (e.g., those using collaborative patterns). But in other cases, this additional effort could prevent teachers from using GLUEPS-AR (or at least, from using it repetitively). That could be the case of teachers with little time available, or that plan to design and set up the technological environment shortly before the actual enactment. In this line, we are already exploring alternatives for enabling teachers to create, directly from their usual learning environments (and thus avoiding the use of additional authoring tools), not very complex learning situations that may include AR and web tools.

Another issue that emerged during the evaluation was the necessity of allowing the students to participate in the creation of the learning situations, in order to enable them not only to be passive receptors of contents, but also creators, something especially important in their training as future teachers. However, GLUEPS-AR, like other approaches based on the use of authoring tools, forces the teacher to predefine all the tools and artifacts to be used by the students during the enactment. We are also exploring how GLUEPS-AR could implement features to improve the flexibility offered to the students in this aspect (Muñoz-Cristóbal et al., 2013).

During the evaluation, several minor technological problems arose, that were solved with the help of a member of the evaluation team. However, in the context in which the learning situation was carried out (an outdoor scenario covering a whole village, with 47 students working in groups), such problems could have overloaded a single teacher. Thus, it is important to anticipate the maximum number of possible issues (e.g., by testing part of the scenario in a nearby context), and explain the students how to detect and solve the known issues. Also, communication with students is important in this kind of scenarios. We used mobile devices and walkie-talkies, but the means for communicating could be also a part of the learning environment and it is a matter for further research. In addition, the teacher should be ready for switching to backup alternatives in the design, and even to put into practice a backup plan if technology would not be available. This is especially important in outdoor scenarios that can be affected by issues related with the weather, the battery of the devices, the internet connection, the mobile coverage, etc. During the enactment of Game of Blazons, the teachers did not need to adapt the design at runtime, but it is a feature that we consider important especially in these kind of scenarios, and that we plan to research.

We should also further explore how to improve the monitoring features of GLUEPS-AR, since during the evaluation we verified that teachers need simple instruments to be able to control and be aware of the students' actions. The GLUEPS-AR awareness features should be enhanced to enable a simpler use by teachers with very little time available during the enactment. Also, the positive feedback received by the teachers to the use of augmented reality for providing runtime user awareness encourages us to continue in this line of research.

We plan to explore the use of GLUEPS-AR in other contexts, and with other teachers, in order to investigate in depth the GLUEPS-AR range of applicability and the support provided for different kind of scenarios. In this line, a possible future work is the comparison of the support provided by different systems to the creation and enactment of a range of learning situations. In addition, further research would be necessary to explore in detail the GLUEPS-AR support to

different pedagogical approaches. A particular pedagogy which we would like to investigate is game-based learning. Although the teachers considered Game of Blazons as a kind of educational game, we would like to explore how GLUEPS-AR supports game-based learning, and how it could enable teachers a *gamification* of their usual learning situations that involve multiple physical and virtual spaces. We also plan to research the learning effects of the use of GLUEPS-AR from the point of view of the students, an important aspect that we have not dealt with in this study.

References

- Alario-Hoyos, C., Bote-Lorenzo, M. L., Gómez-Sánchez, E., Asensio-Pérez, J. I., Vega-Gorgojo, G., & Ruiz-Calleja, A. (2013). GLUE!: An architecture for the integration of external tools in Virtual Learning Environments. *Computers & Education*, *60*(1), 122-137.
- Alario-Hoyos, C., & Wilson, S. (2010, November). *Comparison of the main alternatives to the integration of external tools in different platforms*. Paper presented at the Proceedings of the International Conference of Education, Research and Innovation, ICERI 2010, Madrid, Spain.
- Azuma, R., Bailiot, Y., Behringer, R., Feiner, S., Julier, S., & MacIntyre, B. (2001). Recent advances in augmented reality. *Computer Graphics and Applications, IEEE*, *21*(6), 34-47.
- Billinghurst, M., & Duenser, A. (2012). Augmented Reality in the classroom. *Computer*, *45*(7), 56-63.
- Bonnard, Q., Verma, H., Kaplan, F., & Dillenbourg, P. (2012, September). *Paper Interfaces for Learning Geometry*. Paper presented at the 7th European Conference of Technology Enhanced Learning, EC-TEL 2012, Saarbrücken, Germany.
- Conole, G., & Alevizou, P. (2010). *A literature review of the use of Web 2.0 tools in Higher Education* (A report commissioned by the Higher Education Academy): The Open University.
- Cook, J. (2011, September). *User Generated Contexts Across Spaces – Design Research Perspectives*. Paper presented at the Across Spaces Workshop, European Conference-Technology Enhanced Learning (EC-TEL 2011), Palermo, Italy.
- Cuendet, S., Bonnard, Q., Do-Lenh, S., & Dillenbourg, P. (2013). Designing augmented reality for the classroom. *Computers & Education*, *68*, 557-569.
- Cheng, K.-H., & Tsai, C.-C. (2013). Affordances of Augmented Reality in Science Learning: Suggestions for Future Research. *Journal of Science Education and Technology*, *22*(4), 449-462.
- de-las-Heras-Quirós, P., Román-López, R., Calvo-Palomino, R., Gato, J., & Gato, J. F. (2010, June). *Mobile Augmented Reality browsers should allow labeling objects. A Position Paper for the Augmented Reality on the Web W3C Workshop*. Paper presented at the W3C Workshop: Augmented Reality on the Web, Barcelona, Spain.
- Di Serio, Á., Ibáñez, M. B., & Delgado Kloos, C. (2013). Impact of an augmented reality system on students' motivation for a visual art course. *Computers & Education*, *68*, 586-596.
- Dillenbourg, P., & Jermann, P. (2010). Technology for classroom orchestration. In M. S. Khine & I. M. Saleh (Eds.), *New Science of Learning Cognition Computers and Collaboration in Education* (pp. 1-20): Springer New York.
- Dunleavy, M., Dede, C., & Mitchell, R. (2009). Affordances and Limitations of Immersive Participatory Augmented Reality Simulations for Teaching and Learning. *Journal of Science Education and Technology*, *18*(1), 7-22.

- Echeverría, A., Améstica, M., Gil, F., Nussbaum, M., Barrios, E., & Leclerc, S. (2012). Exploring different technological platforms for supporting co-located collaborative games in the classroom. *Computers in Human Behavior*, 28(4), 1170-1177.
- Enyedy, N., Danish, J. A., Delacruz, G., Kumar, M., & Gentile, S. (2011, July). *Play and Augmented Reality in Learning Physics: The SPASES Project*. Paper presented at the Connecting Computer-Supported Collaborative Learning to Policy and Practice: CSCL2011 Conference Proceedings. Volume I — Long Papers, Hong Kong, China.
- Facer, K., Joiner, R., Stanton, D., Reid, J., Hull, R., & Kirks, D. (2004). Savannah: mobile gaming and learning? *Journal of Computer Assisted Learning*, 20(6), 399-409.
- Fernández-Panadero, C., & Delgado Kloos, C. (2013, November). *PhyMEL. A Framework to Integrate Physical, Mental and Emotional Learning in Meaningfull Experiences and Multidimensional Reports*. Paper presented at the 3rd European Immersive Education Summit (EiED'13), London, UK.
- FitzGerald, E. (2013, June). *Situ8: browsing and capturing geolocated user-created content*. Paper presented at the Proceedings of the CALRG Annual Conference 2013, The Open University, Milton Keynes, UK.
- Gagnon, D. J. (2010). *ARIS. An open source platform for developing mobile learning experiences*. Unpublished Master of Science, University of Wisconsin - Madison.
- Grubert, J., Langlotz, T., & Grasset, R. (2011). *Augmented Reality Browser Survey* (Technical Report No. ICG-TR-1101): Institute for Computer Graphics and Vision, Graz University of Technology, Austria.
- Guba, E. G. (1981). Criteria for assessing the trustworthiness of naturalistic inquiries. *Educational Communication and Technology Journal*, 29(2), 75-91.
- Holden, C. L., & Sykes, J. M. (2011). Leveraging Mobile Games for Place-Based Language Learning. *International Journal of Game-Based Learning*, 1(2), 1-18.
- Horne, C. (2013). QRienteering: Mobilising the M-Learner with Affordable Learning Games for Campus Inductions. In Y. Baek & N. Whitton (Eds.), *Cases on Digital Game-Based Learning: Methods, Models, and Strategies* (pp. 97-118). Hershey, PA, USA: IGI Global.
- Ibáñez, M. B., Maroto, D., García Rueda, J. J., Leony, D., & Delgado Kloos, C. (2012). Architecture for collaborative learning activities in hybrid learning environments. *Journal of Universal Computer Science*, 18(15), 2187-2202.
- Jorrín-Abellán, I. M., & Stake, R. E. (2009). Does Ubiquitous Learning Call for Ubiquitous Forms of Formal Evaluation? An Evaluand Oriented Responsive Evaluation Model. *Ubiquitous Learning: An International Journal*, 1(3), 71-82.
- Kaddouci, S., Peter, Y., Vantrois, T., & Laporte, P. (2010). Coupling Pedagogical Scenarios and Location-based Services for Learning. *Learning Technology newsletter*, 12(4), 11-14.
- Kamarainen, A. M., Metcalf, S., Grotzer, T., Browne, A., Mazzuca, D., Tutwiler, M. S., et al. (2013). EcoMOBILE: Integrating augmented reality and probeware with environmental education field trips. *Computers & Education*, 68, 545-556.
- Kato, H., & Billinghurst, M. (1999, October). *Marker tracking and HMD calibration for a video-based augmented reality conferencing system*. Paper presented at the 2nd IEEE and ACM International Workshop on Augmented Reality (IWAR '99), San Francisco, CA, USA.
- Keller, C. (2005). Virtual learning environments: Three implementation perspectives. *Learning, Media and Technology*, 30(3), 299-311.
- Kerawalla, L., Luckin, R., Seljeflot, S., & Woolard, A. (2006). "Making it real": exploring the potential of augmented reality for teaching primary school science. *Virtual Reality*, 10(3), 163-174.
- Klopfer, E. (2008). *Augmented Learning: Research and Design of Mobile Educational Games*. Cambridge, MA. : The MIT Press.

- Klopfer, E., Sheldon, J., Perry, J., Rosenheck, L., Squire, K., Mathews, J., et al. (2011, July). *Augmented reality games: place-based digital learning*. Paper presented at the Proceedings of the 9th International CSCL Conference, Hong Kong, China.
- Klopfer, E., & Squire, K. (2008). Environmental Detectives—the development of an augmented reality platform for environmental simulations. *Educational Technology Research and Development, 56*(2), 203-228.
- Koper, R. (2005). An introduction to learning design. In R. Koper & C. Tattersall (Eds.), *Learning Design. A Handbook on Modelling and Delivering Networked Education and Training* (pp. 3-20): Springer.
- Kurti, A., Spikol, D., & Milrad, M. (2008). Bridging outdoors and indoors educational activities in schools with the support of mobile and positioning technologies. *International Journal of Mobile Learning and Organisation, 2*(2), 166-186.
- Laurillard, D., Charlton, P., Craft, B., Dimakopoulos, D., Ljubojevic, D., Magoulas, G., et al. (2013). A constructionist learning environment for teachers to model learning designs. *Journal of Computer Assisted Learning, 29*(1), 15-30.
- Laviole, J., & Hachet, M. (2012, March). *PapARt: Interactive 3D graphics and multi-touch augmented paper for artistic creation*. Paper presented at the IEEE Symposium on 3D User Interfaces (3DUI), Orange County, CA, USA.
- Li, L., Zheng, Y., Ogata, H., & Yano, Y. (2004, September). *A framework of ubiquitous learning environment*. Paper presented at the The Fourth International Conference on Computer and Information Technology (CIT 2004), Wuhan, China.
- Luff, P., Adams, G., Bock, W., Drazin, A., Frohlich, D., Heath, C., et al. (2007). Augmented Paper: Developing Relationships Between Digital Content and Paper. In N. Streitz, A. Kameas & I. Mavrommati (Eds.), *The Disappearing Computer* (Vol. 4500, pp. 275-297): Springer Berlin Heidelberg.
- Mackay, W. E. (1998, May). *Augmented reality: linking real and virtual worlds: a new paradigm for interacting with computers*. Paper presented at the Proceedings of the working conference on Advanced visual interfaces, LAquila, Italy.
- Martín-Gutiérrez, J. (2011, June-July). *Generic user manual for maintenance of mountain bike brakes based on augmented reality*. Paper presented at the Proceedings of the 28th International Symposium on Automation and Robotics in Construction, ISARC 2011, Seoul, Korea.
- Martín-Gutiérrez, J., Saorín, J. L., Contero, M., Alcañiz, M., Pérez-López, D. C., & Ortega, M. (2010). Design and validation of an augmented book for spatial abilities development in engineering students. *Computers & Graphics, 34*(1), 77-91.
- Miles, M. B., & Huberman, A. M. (1994). *Qualitative data analysis. An expanded sourcebook*. Thousand Oaks, California, USA: SAGE Publications Inc.
- Muñoz-Cristóbal, J. A., Jorrín-Abellán, I. M., Asensio-Pérez, J. I., Martínez-Monés, A., Prieto, L. P., & Dimitriadis, Y. (2015). Supporting Teacher Orchestration in Ubiquitous Learning Environments: A Study in Primary Education. *Transactions on Learning Technologies, 8*(1), 83-97.
- Muñoz-Cristóbal, J. A., Prieto, L. P., Asensio-Pérez, J. I., Jorrín-Abellán, I. M., Martínez-Monés, A., & Dimitriadis, Y. (2013, September). *Sharing the Burden: Introducing Student-Centered Orchestration in Across-Spaces Learning Situations*. Paper presented at the Proceedings of the 8th European Conference on Technology Enhanced Learning (ECTEL), Paphos, Cyprus.
- Muñoz-Cristóbal, J. A., Prieto, L. P., Asensio-Pérez, J. I., Martínez-Monés, A., Jorrín-Abellán, I. M., & Dimitriadis, Y. (2014). Deploying learning designs across physical and web spaces: Making pervasive learning affordable for teachers. *Pervasive and Mobile Computing, 14*, 31-46.
- Niramitranon, J., Sharples, M., Greenhalgh, C., & Lin, C.-P. (2010, April). *Orchestrating Learning in a One-to-One Technology Classroom*. Paper presented at the 6th IEEE International

- Conference on Wireless, Mobile and Ubiquitous Technologies in Education (WMUTE), Kaohsiung, Taiwan.
- Orlikowski, W. J., & Baroudi, J. J. (1991). Studying information technology in organizations: Research approaches and assumptions. *Information Systems Research*, 2(1), 1-28.
- Papagiannakis, G., Singh, G., & Magnenat-Thalmann, N. (2008). A survey of mobile and wireless technologies for augmented reality systems. *Computer Animation and Virtual Worlds*, 19(1), 3-22.
- Pence, H. E. (2010). Smartphones, Smart Objects, and Augmented Reality. *The Reference Librarian*, 52(1-2), 136-145.
- Pérez-López, D., Contero, M., & Alcañiz, M. (2010, July). *Collaborative Development of an Augmented Reality Application for Digestive and Circulatory Systems Teaching*. Paper presented at the IEEE 10th International Conference on Advanced Learning Technologies (ICALT), 2010 Sousse, Tunisia.
- Pérez-Sanagustín, M., Martínez, A., & Delgado Kloos, C. (2012). EtiquetAR: a Tool for Designing Tag-based Mobile Augmented Reality Experiences. *Bulletin of the IEEE Technical Committee on Learning Technology*, 14(4), 27-30.
- Pérez-Sanagustín, M., Ramirez-Gonzalez, G., Hernández-Leo, D., Muñoz-Organero, M., Santos, P., Blat, J., et al. (2011). Discovering the campus together: A mobile and computer-based learning experience. *Journal of Network and Computer Applications*, 35(1), 167-188.
- Prieto, L. P., Asensio-Pérez, J. I., Muñoz-Cristóbal, J. A., Dimitriadis, Y., Jorrín-Abellán, I. M., & Gómez-Sánchez, E. (2013). Enabling teachers to deploy CSCL designs across multiple Distributed Learning Environments. *Transactions on Learning Technologies*, 6(4), 324-336.
- Prieto, L. P., Dlab, M. H., Gutiérrez, I., Abdulwahed, M., & Balid, W. (2011). Orchestrating technology enhanced learning: a literature review and a conceptual framework. *International Journal of Technology Enhanced Learning*, 3(6), 583-598.
- Prieto, L. P., Wen, Y., Caballero, D., & Dillenbourg, P. (2014). Review of Augmented Paper Systems in Education: An Orchestration Perspective. *Journal of Educational Technology & Society*, 17(4), 169-185.
- Robles, G., Gonzales-Barahona, J. M., & Fernandez-Gonzales, J. (2011, April). *Implementing Gymkhanas with Android smartphones: A multimedia m-learning game*. Paper presented at the Global Engineering Education Conference (EDUCON), Amman, Jordan.
- Rouillard, J., & Laroussi, M. (2008, October). *PerZoovasive: Contextual Pervasive QR Codes As Tool to Provide an Adaptive Learning Support*. Paper presented at the Proceedings of the 5th International Conference on Soft Computing As Transdisciplinary Science and Technology, Paris, France.
- Salvador-Herranz, G., Pérez-López, D., Alcañiz, M., & Contero, M. (2011). *Augmented reality at the primary school: a pilot study on a Natural Sciences course*. Paper presented at the Across Spaces Workshop, European Conference-Technology Enhanced Learning, Palermo, Italy.
- Santos, P., Pérez-Sanagustín, M., Hernández-Leo, D., & Blat, J. (2011). QuesTInSitu: From tests to routes for assessment in situ activities. *Computers & Education*, 57(4), 2517-2534.
- Santos, P., Pérez-Sanagustín, M., Hernández-Leo, D., & Blat, J. (2012, July). *Space-aware Design Factors for Located Learning Activities Supported with Smart Phones*. Paper presented at the IEEE 10th International Symposium on Parallel and Distributed Processing with Applications (ISPA), Madrid, Spain.
- Sheehy, K., Ferguson, R., & Clough, G. (2014). *Augmented Education: Bringing Real and Virtual Learning Together (Digital Education and Learning)*. New York, NY, USA: Palgrave Macmillan.
- Sintoris, C., Stoica, A., Papadimitriou, I., Yiannoutsou, N., Komis, V., & Avouris, N. (2012). MuseumScrabble: Design of a Mobile Game for Children's Interaction with a Digitally

- Augmented Cultural Space. *International Journal of Mobile Human Computer Interaction (IJMHCI)*, 2(2), 53-71.
- Sobreira, P., & Tchounikine, P. (2012). A model for flexibly editing CSCL scripts. *International Journal Of Computer-Supported Collaborative Learning*, 7(4), 567-592.
- Spikol, D., & Eliasson, J. (2010, April). *Lessons from Designing Geometry Learning Activities that Combine Mobile and 3D Tools*. Paper presented at the Proceedings of the 6th IEEE International Conference on Wireless, Mobile and Ubiquitous Technologies in Education (WMUTE), Kaohsiung, Taiwan.
- Squire, K. D., & Jan, M. (2007). Mad City Mystery: Developing Scientific Argumentation Skills with a Place-based Augmented Reality Game on Handheld Computers. *Journal of Science Education and Technology*, 16(1), 5-29.
- Stake, R. E. (2004). *Standards-based and responsive evaluation*. Thousand Oaks, CA, USA: SAGE Publications Inc.
- Stevense, D., & van der Tak, P. (2010). *iBetelgeuse: an Augmented Reality Browser for iPhone*. Unpublished Bachelor's Project, Delft University of Technology, Delft.
- Ternier, S., Klemke, R., Kalz, M., van Ulzen, P., & Specht, M. (2012). ARLearn: Augmented reality meets augmented virtuality. *Journal of Universal Computer Science*, 18(15), 2143-2164.
- van Krevelen, D. W. F., & Poelman, R. (2010). A Survey of Augmented Reality Technologies, Applications and Limitations. *The International Journal of Virtual Reality*, 9(2), 1-20.
- Villasclaras-Fernández, E., Hernández-Leo, D., Asensio-Pérez, J. I., & Dimitriadis, Y. (2013). Web Collage: An implementation of support for assessment design in CSCL macro-scripts. *Computers & Education*, 67, 79-97.
- Wellner, P. (1993). Interacting with paper on the DigitalDesk. *Communications of the ACM - Special issue on computer augmented environments: back to the real world*, 36(7), 87-96.
- Wu, H.-K., Lee, S. W.-Y., Chang, H.-Y., & Liang, J.-C. (2013). Current status, opportunities and challenges of augmented reality in education. *Computers & Education*, 62, 41-49.
- Yuen, S. C.-Y., Yaoyuneyong, G., & Johnson, E. (2011). Augmented Reality: An Overview and Five Directions for AR in Education. *Journal of Educational Technology Development and Exchange*, 4(1), 119-140.

Chapter 4

Learning buckets: Helping teachers introduce flexibility in the management of learning artifacts across spaces

This chapter describes the research works carried out in the first part of the second cycle of the research process (see Figure 4.1). During the first cycle of research (Chapter 2 and Chapter 3) we detected a limitation in GLUEPS-AR regarding the flexibility offered to the students to manage their learning artifacts during the enactment. Since GLUEPS-AR relied on a learning design approach, it was somewhat rigid in the flexibility provided to the students to take technological, contextual or arbitrary decisions during the enactment, regarding the tools or artifacts to use (e.g., decide what tools to use or where to position the artifacts they create). Thus, the knowledge gained in the first cycle, together with a study of the state of the art related to approaches that provide flexibility in the management of learning artifacts during the enactment, led us to propose the learning bucket notion, and the Bucket-Server system (which implements such notion). This chapter focuses on these two proposals, which are also two main contributions of the thesis (see Figure 4.2), exploring how they overcome the limitations of alternative approaches. The chapter also presents an evaluation of the support provided by our proposals to the aforementioned limitations. The evaluation comprised a feature analysis and a pilot study. The feature analysis consisted in a systematic comparison of the support provided to a set of requirements (features) by the Bucket-Server and alternative approaches, and the pilot study was carried out in a workshop, in which learning buckets were used by experts in the field of across-spaces learning. Figure 4.2 indicates the contributions and evaluations works covered by the chapter in the general diagram of the thesis. Additional details about the Bucket-Server system can be found in Appendix B, and general templates of the questionnaires used are included in Appendix C. The content of this chapter is presented as a paper, prepared for its future submission to an international journal.

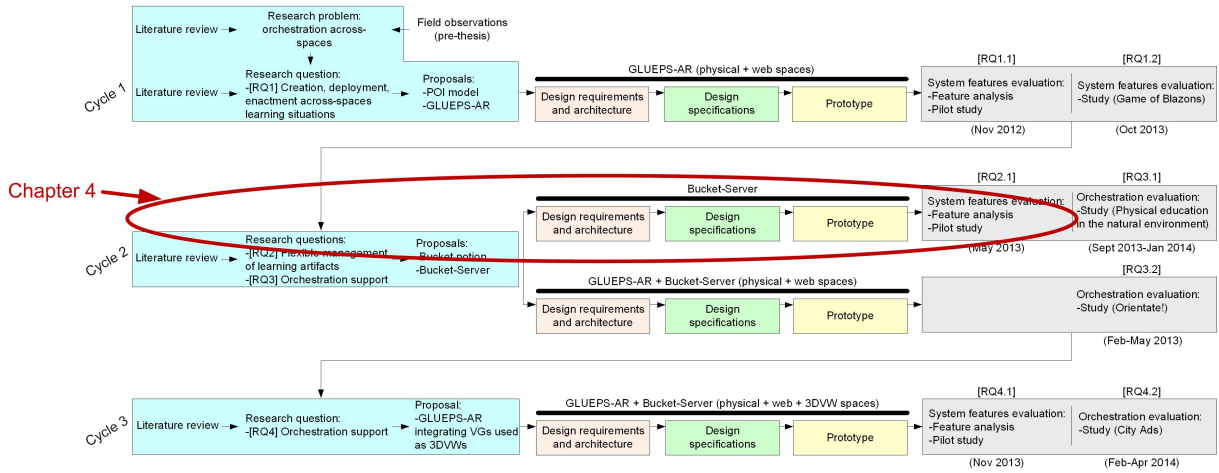

Figure 4.1: Part of the research process covered by Chapter 4.

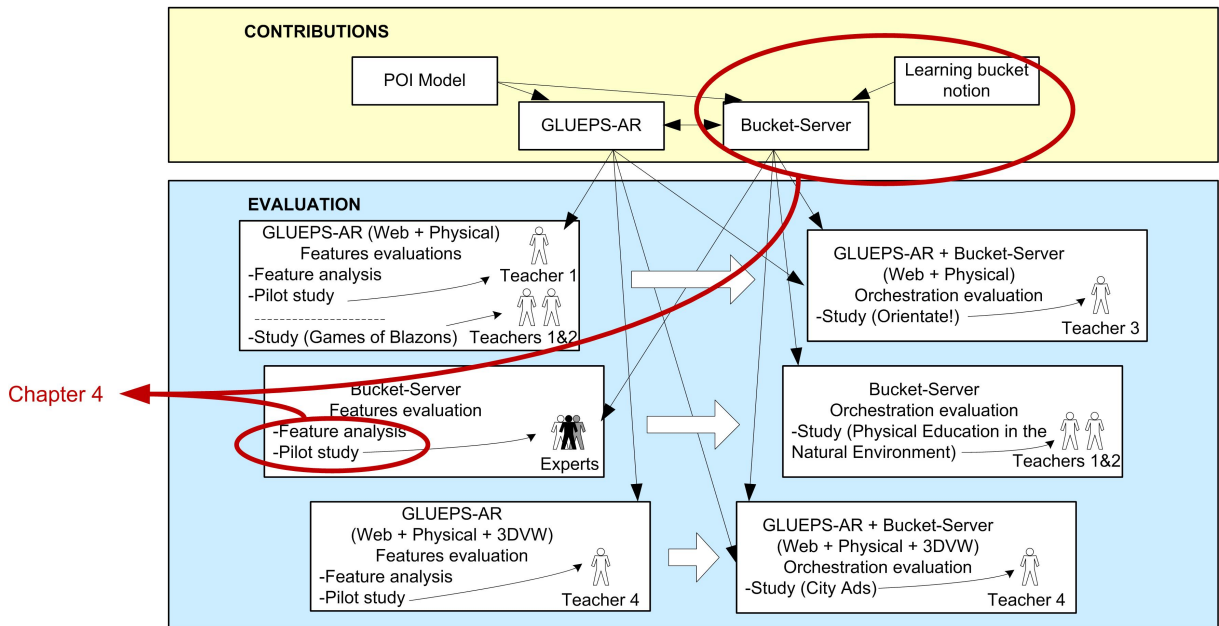

Figure 4.2: Contributions and evaluation works covered by Chapter 4.

To be submitted

Learning buckets: Helping teachers introduce flexibility in the management of learning artifacts across spaces

Abstract: The advance of technology is generating rich opportunities for learning beyond the walls of the classroom, across different physical and virtual spaces. However, current proposals are either highly teacher centered and inflexible in the students' management of learning artifacts during the enactment, or allow little/no control to the teachers, in terms of such students' learning artifact management. Moreover, most of these proposals are disconnected from practices and tools currently in use in the classroom. How can we achieve a middle ground between flexible student-centeredness and keeping the teacher in control of an across-spaces learning situation? Aiming to overcome such challenge, we propose the notion of learning bucket: a container of positionable learning artifacts which are generated and/or accessed across-spaces by the students during the enactment, according to constraints configured by teachers at design time. The evaluation carried out, based on a feature analysis and a pilot study, suggests that learning buckets can be an interesting tool to evolve from teacher- to student-centered approaches, while maintaining the teacher control of the students' actions. The evaluation also indicates that learning buckets improve the support of the alternative proposals to across-spaces learning situations.

1 Introduction

The advance of technology in the last decades is blurring the walls of the traditional classroom thus allowing learning to happen in other educational spaces (Cope & Kalantzis, 2010; Sharples, Sanchez, Milrad, & Vavoula, 2009). With the help of technologies like mobile devices (Chan et al., 2006) and Augmented Reality (AR) (Wu, Lee, Chang, & Liang, 2013), virtual spaces (e.g., a web space using a Virtual Learning Environment, VLE), may be combined with physical spaces (classroom, museums, the streets of a city, a park, etc.), forming Ubiquitous Learning Environments (ULEs) (Li, Zheng, Ogata, & Yano, 2004). More recently, different systems have been proposed with the aim of helping teachers carry out across-spaces learning situations (Sharples, et al., 2009; Wong & Looi, 2011), i.e., learning situations that seamlessly integrate activities taking place in the different physical and virtual spaces that make up a ULE. Several of these approaches try to enable teachers create such learning situations by means of authoring tools, which translate their pedagogical ideas into a computerized form (Klopfer et al., 2011; Muñoz-Cristóbal et al., 2014; Santos, Pérez-Sanagustín, Hernández-Leo, & Blat, 2011). However, most of these proposals force students to follow a learning design in which most details (e.g., tools to use, such as Google Docs¹, or learning artifacts to produce, such as a Google Docs document) are specified a priori, thus reducing the student autonomy during the enactment. Although a certain level of guidance, or scaffolding, may be desirable in some pedagogical approaches (such as in collaborative learning by using *scripts*, see, e.g.,

¹ <http://www.google.com/docs/about/>. Last access April 2015

Weinberger, Kollar, Dimitriadis, Mäkitalo-Siegl, & Fischer, 2009), too much coercion can prevent the necessary natural interactions of students that promote learning (Dillenbourg, 2002). Therefore, a certain level of flexibility might be desirable, in order to enable teachers and students introduce modifications in the initially designed learning situation, without altering its pedagogical intention (Dillenbourg & Tchounikine, 2007). This “agency issue” is defined by some authors (Cope & Kalantzis, 2010) as a clear challenge for practitioners that try to enact across-spaces learning situations. Such an evolution towards more student-centered approaches could contribute to the autonomy of the students (Hannafin & Land, 1997). On the other hand, too much flexibility could eventually end up in a situation in which students perform learning tasks (and even interact among them) in a way that does not reflect the pedagogical intentions of the teacher (Dillenbourg & Tchounikine, 2007). So, there is a need for a compromise between flexibility and guidance, which should be defined by the teacher based on her pedagogical intentions. Such flexibility should involve only to those entities of the learning situations that do not alter the pedagogical essence of the learning situations (Dillenbourg & Tchounikine, 2007). In this paper, we focus on the flexibility during the enactment in the use of learning artifacts: initial resources created by the teacher, as well as intermediate products and final outcomes of the learning process that can be created by the students and shared across activities and spaces. Learning artifacts are important elements in different pedagogical approaches, such as Computer Supported Collaborative Learning and Inquiry Based Learning, IBL (see, e.g., De Jong et al., 2010; Miao, Hoeksema, Hoppe, & Harrer, 2005). Different proposals in the literature, such as VLEs, Personal Learning Environments (PLEs) or IBL systems, provide a degree of flexibility in the management of learning artifacts (e.g., Moodle²; LAMS³; Casquero, Portillo, Ovelar, Benito, & Romo, 2010; Mulholland et al., 2012). Nevertheless, such approaches present limitations to their use by teachers in across-spaces learning situations: the limited support to combine seamlessly the different physical and virtual spaces (Milrad et al., 2013); the isolation from other activities and systems of the teachers’ current practice (Cuendet, Bonnard, Do-Lenh, & Dillenbourg, 2013); and the limited support for teachers to regulate the degree of flexibility offered to the students (Dillenbourg & Tchounikine, 2007; Weinberger, et al., 2009). Thus, in the present paper we face the problem of *how technology can help introduce flexibility in the management of learning artifacts during the enactment of across-spaces learning situations, guided by the teachers’ pedagogical decisions, and in a way that is integrated with current practice.*

Aiming to provide a flexible management of learning artifacts in across-spaces learning situations overcoming the mentioned limitations, we propose the notion of *learning bucket* and a system which implements it: the *Bucket-Server*. A learning bucket is a container of positionable learning artifacts that is configured by teachers with *constraints* to limit what the students can do within it. Learning buckets are included by teachers in the activities of their learning designs, and accessed afterwards across-spaces. The students, during the enactment, create and access the buckets’ artifacts across-spaces. We have implemented the learning bucket notion in a system, the *Bucket-Server*, which enables the integration of learning buckets into existing software applications focused on different learning spaces (e.g., VLEs in web spaces, AR apps in physical spaces). The *Bucket-Server* can be also integrated with

² <https://moodle.org>. Last access April 2015

³ <http://lamsfoundation.org>. Last access April 2015

multiple existing artifact providers, thus enabling the use of common tools, such as widgets or Web 2.0 tools. A prototype of the Bucket-Server was used in an evaluation in order to assess the support that it provides in relation to the identified limitations (across-spaces use, integration into the existing practice, teacher-controlled flexibility). The evaluation consisted of a feature analysis (a systematic comparison of the proposal with alternatives in literature) and a pilot study (in which educators and researchers experts in across-spaces learning used the Bucket-Server prototype).

The structure of the document is the following: the next section presents a review of existing approaches that provide flexibility in the management of learning artifacts, as well as some identified limitations for their use by teachers in across-spaces learning situations, and design requirements proposed for overcoming such limitations. Section 3 describes the learning bucket notion and system. The evaluation conducted is explained in Section 4, and finally, Section 5 summarizes the main conclusion obtained.

2 Related work and design requirements

In this section we review existing approaches in the literature proposing solutions for the flexible management of learning artifacts during the enactment of learning situations. Then, we identify a set of limitations for the use of such approaches by teachers in across-spaces learning situations, and we propose a set of design requirements for systems aiming to overcome these limitations.

2.1 Approaches providing a flexible management of learning artifacts during the enactment.

The learning design approach (Koper, 2005) relies on the definition, at design time, of the details of learning situations in a standardized language so that such details can be later shared and reused by the teachers. This makes systems based on learning design languages somewhat rigid in what students are allowed to do during the enactment. Despite this fact, **certain learning design languages include features to provide flexibility**. That is the case of LDL, with the information element *rule* (Martel, Vignollet, Ferraris, David, & Lejeune, 2006), the language implemented in Pedagogical Patern Collector Designer, with the information element *resource* (Laurillard et al., 2013), and IMS LD (IMS Global Learning Consortium, 2003), with the information elements *property* and *condition*. Miao, Hoeksema, Hoppe & Harrer (2005) describe the limitations of IMS LD for modeling artifacts generated by students during the enactment. They proposed a scripting language which includes an *artifact* information element, enabling the creation of learning artifacts during the enactment. They also extended IMS LD's use of properties and conditions, adding an *action* information element, to define conditions affecting any element of the script. Other authors propose **systems that integrate learning design languages with other languages that would include the required flexibility**. That is the case of the system proposed by de-la-Fuente-Valentín, Leony, Pardo & Delgado Kloos (2008), that integrates IMS LD and LISL (a language to create web-mashup learning environments) to provide flexibility during the enactment in the configuration of the learning environment. An alternative proposal is the Action Server developed by Prieto, Muñoz-Cristóbal, Dimitriadis & Asensio-Pérez (2013), **a system that includes flexibility during the**

instantiation and the enactment of learning designs which can have been defined in different learning design languages. The Action Server allows different modifications in the learning design (in activities, groups, participants and resources) during the enactment, triggered by means of tangible interfaces based on fiducial markers.

Also, the **VLEs normally implement certain types of modules, activities or tools** (the term may vary depending on the platform) **to provide flexibility** during the enactment in the management of learning artifacts of the students. For instance, the VLE may enable the students to choose between different tools, to create artifacts of different types or to upload their created artifacts (usually a file) to the VLE. An example is the *Assignment*⁴ in Moodle, which enables students to upload files, which once uploaded are only visible by the teacher. Other examples are some LAMS functionalities⁵, such as: *Data collection* (allowing students to populate a data base, created by the teacher, with records of different type, such as text, date, file, latitude/longitude, etc.); *Optional activity* (enabling the teacher to define a set of activities among which the students can conduct only some of them within a range defined by the teacher); *Share resources* (allowing the students to add and share URLs and files); and *Submit files* (enabling the students to upload files). Another example is WISE⁶ (Linn, Clark, & Slotta, 2003), a VLE focused on IBL, in which the teacher, with an authoring tool, adds *steps* in the activities, including in each *step* an internal tool. The teacher can configure the internal tool defining what the student is allowed to do. Another interesting case is the VLE for mobile devices GoKnow MLE⁷ (see, e.g., Zhang et al., 2010). It is a system that enables teachers to create *projects* in which activities or resources can be included. An activity basically implies the use of a tool that the teacher selects and the students can employ to generate an outcome. This VLE also allows the sequencing of activities, and the students can use multiple tools from among those installed in the mobile device (e.g., the different Microsoft Office applications). Another proposal is SCY-Lab (De Jong, et al., 2010), a learning environment where entities named Emerging Learning Objects (ELOs) take a principal role. ELOs are learning objects created by the students, and can be of multiples types (a dataset, a document, etc). ELOs are annotated with metadata, and there is an ELO repository to search them, being the ELOs reusable and shareable.

A different approach for including flexibility in the management of learning artifacts during the enactment is the **integration of widget⁸ containers into VLEs**. Teachers can configure a set of widgets to be used by the students, who may choose among such widgets during the enactment. Approaches in this line are the Wookie server (Griffiths, Johnson, Papat, Sharples, & Wilson, 2012; Wilson, et al., 2011), based on the W3C⁹ widget specifications; the application Composer (Simon et al., 2013) of the iTEC¹⁰ project; the system proposed by Bogdanov (2013); and SOCKET (Clark & Booth, 2006), a container for educational services based on the e-

⁴ http://docs.moodle.org/23/en/Assignment_module. Last access April 2015

⁵ <http://wiki.lamsfoundation.org/display/lamsdocs/LAMS+Tutorials>. Last access April 2015

⁶ <http://wise.berkeley.edu>. Last access April 2015

⁷ http://goknow.com/products_education.html. Last access April 2015

⁸ Widgets are little interactive applications that can be embedded in other platforms (Wilson, Sharples, Griffiths, & Papat, 2011)

⁹ <http://www.w3.org/TR/widgets/>. Last access April 2015

¹⁰ <http://itec.eun.org>. Last access April 2015

Learning Framework (ELF). In these approaches, teachers typically select the widgets that the students will be permitted to use.

Personal Learning Environments (PLEs) (Olivier & Liber, 2001) also provide flexibility to the students during the enactment. In a PLE, the student is able to personalize the learning environment, and to choose between widespread tools in the Web (Schaffert & Hilzensauer, 2008; White & Davis, 2011; Wilson et al., 2007). Such tools are not restricted to the institutional scope, but they can also belong to the student's personal or social sphere. There are different PLE implementation proposals, such as those based on a mashup of Web 2.0 tools (Torres Kompen, Edirisingha, & Mobbs, 2008; Wild, Mödrtscher, & Sigurdarson, 2008), or on the integration of widgets with VLEs and personal web applications (e.g., blogs) (Wilson, Sharples, & Griffiths, 2008). In contrast to approaches that only integrate services or tools of the personal sphere of the student (Rahimi, van den Berg, & Veen, 2012; Torres Kompen, et al., 2008), some authors propose to cover both, personal and institutional spheres, by integrating VLEs and PLEs (Casquero, et al., 2010; Conde, García-Peñalvo, Alier, Mayol, & Fernández-Llamas, 2014; White & Davis, 2011; Wilson, et al., 2008). They are known as institutional PLEs (iPLEs) (Casquero, et al., 2010). In addition, some authors propose to use learning design authoring tools to enable teachers the deployment of designs in PLEs (Peter, Villasclaras-Fernández, & Dimitriadis, 2013), as a way of complementing the structured character of the learning design languages and the flexibility of PLEs.

An alternative proposed by other authors is **the use of authoring tools by the students**. Using such tools, the students can create their own learning activities or artifacts, favoring thus student-centered pedagogical approaches. An example in this line is the system proposed in the Metafora¹¹ project (Dragon et al., 2013; Harrer, Pfahler, & Lingnau, 2013), in which the students can create learning designs. Moreover, authoring tools such as BuildAR¹² (Billinghurst & Duenser, 2012) and EtiquetAR¹³ (Pérez-Sanagustín, Martínez, & Delgado Kloos, 2012), allow students to create and position learning artifacts in physical spaces.

Other approaches providing flexibility in the students' management of artifacts include the **systems enabling data gathering by the students, mainly in field trips**. The most characteristic example is the support to IBL scenarios in which students are expected to "collect" data, by taking pictures, recording videos or making measurements using multiple sensors and probes (e.g. temperatures, sound levels, etc.). Several systems have been proposed to enable IBL scenarios of this type, such as Myartspace (Vavoula, Sharples, Rudman, Meek, & Lonsdale, 2009), nQuire¹⁴ (Herodotou, Villasclaras-Fernández, & Sharples, 2014; Mulholland, et al., 2012; Villasclaras-Fernandez, Sharples, Kelley, & Scanlon, 2013), Zydeco¹⁵ (Cahill, Kuhn, Schmoll, Pompe, & Quintana, 2010), Situ8¹⁶ (FitzGerald, 2013), LEMONADE (Giemza, Bollen, Seydel, Overhagen, & Hoppe, 2010), SMILE (Seol, Sharp, & Kim, 2011), weSPOT¹⁷ (Mikroyannidis et al., 2013), and the system developed in the project LETS GO (Vogel, Spikol, Kurti, & Milrad, 2010).

¹¹ <http://www.metafora-project.org>. Last access April 2015

¹² <http://www.buildar.co.nz>. Last access April 2015

¹³ <http://etiquetar.com.es>. Last access April 2015

¹⁴ <http://www.nquire.org.uk/home>. Last access April 2015

¹⁵ <http://zydeco.soe.umich.edu>. Last access April 2015

¹⁶ <http://www.situ8.org>. Last access April 2015

¹⁷ <http://inquiry.wespot.net>. Last access April 2015

There are also context-awareness systems, such as HyCon (Hansen & Bouvin, 2009), that without a focus on IBL pedagogies, enable the students to gather data during field trips.

2.2 Limitations of the reviewed approaches and design requirements

All proposals described in the previous section provide, in a way or another, a flexible management of learning artifacts during the enactment. This flexibility enables the students to take their own decisions during the enactment regarding learning artifacts (Harrer, et al., 2013). Moreover, it enables the teachers to give responsibility to the students about their learning process (Mikroyannidis, et al., 2013), while sharing the management load with them (Sharples, 2013). However, the reviewed approaches are limited in how they can be used by teachers in across-spaces learning situations. In this section, we identify three limitations that may hamper the use of the approaches by teachers in these across-spaces scenarios (Table 1). From these limitations, we can derive a list of design requirements (DR, see Table 2) to ease their usage in educational settings.

1. Most of the described approaches **provide limited support for their use in across-spaces learning situations with activities in different virtual and physical spaces** (see Table 1 and DR1, DR2, DR3 in Table 2). The seamless combination of different learning spaces has been marked recently by the Technology Enhanced Learning research community as one of the main topics to explore (Milrad, et al., 2013; Woolf, 2010). Such combination of multiple spaces in ULEs blurs the boundaries of the physical classroom, and merges, for instance, the structured character of formal education, with the participatory affordances of VLEs (Keller, 2005), and the possibilities for contextual learning of outdoor learning (Dyson, Litchfield, Lawrence, Raban, & Leijdekkers, 2009). The awareness of the learner context is an important factor to may achieve seamless transitions between the learning spaces (Li, et al., 2004; Milrad, et al., 2013). Thus, the students should be able to create and access, contextually, learning artifacts across different spaces (Milrad, et al., 2013). The use of different positioning types (i.e., the way of linking virtual artifacts with the space of interest) enables the detection of context in spaces with different technological constraints (e.g., a GPS outdoors, and markers indoors; Santos, Pérez-Sanagustín, Hernández-Leo, & Blat., 2012). The approaches that are affected by this limitation complicate that students, for instance, can create in the classroom learning artifacts related to a specific outdoor context (e.g., a type of tree common in a nearby park), and access afterwards the artifacts in such context (e.g., when they are close to trees of the mentioned type).
2. Several of the reviewed approaches only enable activities which are not embedded into existing classroom practice. Thus, current solutions **do not allow the integrated use of technologies already existing in teacher practice** (see Table 1 and DR4, DR5 in Table 2), such as VLEs (Keller, 2005) and Web 2.0 tools (Conole & Alevizou, 2010). This can create seams in the operation of the different systems (Billinghurst & Kato, 1999) and can impact negatively in the teachers' orchestration load and in what some authors call the classroom usability (Cuendet, et al., 2013; Prieto, Wen, Caballero, & Dillenbourg, 2014). This limitation may prevent, for instance, the usage of widespread tools (e.g., Google Docs) in outdoor activities, and the subsequent reuse

by other students of the artifacts produced (e.g., a Google Docs document) in the official VLE of the institution (e.g., Moodle).

- Several of the approaches **do not enable teachers to control the degree of flexibility offered to students**, or do so in a very restricted way (e.g., enable/disable such flexibility) (see Table 1 and DR6 in Table 2). In order to let teachers control the types of actions that the students may (or may not) perform, this flexibility should be directed by the teacher pedagogical design. Teachers should be able to specify the type of flexibility they want to promote, according to their pedagogical intentions, and at the same time be sure that the learning design maintains its pedagogical essence (Dillenbourg & Tchounikine, 2007; Weinberger, et al., 2009). Dillenbourg & Tchounikine (2007) propose to use the notions of intrinsic and extrinsic constraints in scripts, defining the elements that can be (extrinsic) and cannot be (intrinsic) modified by teachers and students, in order to preserve the pedagogical essence (the learning principles) of the script. Thus, extrinsic constraints would be induced by issues such as *technological choices* (e.g., tools to use), *contextual factors* (e.g. location) or *arbitrary decisions* (e.g., number of students per group). According to this conceptualization, learning artifacts are elements of across-spaces learning situations, affected by extrinsic constraints, and therefore, in which flexibility can be introduced. Decisions regarding the management of learning artifacts, such as those related to the tools to use (technological choices), the location and creation time of the artifacts (contextual factors) and the users allowed to create/access artifacts (arbitrary decisions) do not need to be predefined and rigid. Such decisions could be variable and be taken in different moments of a learning situation (e.g., during the enactment) by the teachers and the students. Approaches affected by this limitation would, e.g., prevent teachers from adapting the range of possible tools to use in accordance with the characteristics of different groups of students.

Table 1. Support provided by the analyzed approaches to the identified limitations. A "X" indicates that the approach is affected by the limitation

Limitation	Billinghurst et al. 2012	Bogdanov 2013	Cahill et al. 2010	Casquero et al. 2010	Clark et al. 2006	Conde et al. 2014	de-la-Fuente et al. 2008	De Jong et al. 2010	FitzGerald 2013	Giemza et al. 2010	Griffiths et al. 2012	Hansen et al. 2009	Harrer et al. 2013	IMS LD	LAMS	Laurillard et al. 2013	Linn et al. 2003	Martel et al. 2006	Miao et al. 2005	Mikroyannidis et al. 2013	Moodle	Mulholland et al. 2012	Perez-Sanagustin et al. 2012	Peter et al. 2013	Prieto et al. 2013	Rahimi et al. 2012	Seol et al. 2011	Simon et al. 2013	Torres et al. 2008	Vavoula et al. 2009	Vogel et al. 2010	W3C widgets	White et al. 2011	Wild et al. 2008	Zhang et al. 2010			
1	X		X	X	X	X	X	X		X		X	X	X	X	X	X	X	X	X	X	X	X	X	X	X	X	X	X	X	X	X	X	X	X	X	X	X
2	X		X				X	X	X			X	X	X	X	X	X	X	X	X	X	X	X	X	X	X	X	X	X	X	X	X	X	X	X	X	X	X
3	X	X			X		X		X			X											X	X	X	X	X		X	X	X	X			X	X		

Limitations:

- Limited support to across-spaces learning situations with activities in different virtual and physical spaces
- Limited integration with technologies already existing in teacher practice
- Limited control for teachers of the degree of flexibility offered to students in the management of learning artifacts during the enactment

Table 2. Limitations of existing approaches and design requirements proposed to overcome such limitations

Limitations	Design requirements
1. Limited support to across-spaces learning situations with activities in different virtual and physical spaces	DR1. Enable teachers and students to position learning artifacts in different kinds of spaces (e.g., web and physical spaces)
	DR2. Support different positioning types (geoposition, markers, etc.)
	DR3. Enable teachers and students to access contextually the same learning artifact from different kinds of spaces (e.g., web and physical spaces)
2. Limited integration with technologies already existing in teacher practice	DR4. Enable learning situations supported by different ICT-enabled learning environments commonly used in existing educational practice (e.g., multiple VLEs)
	DR5. Enable the integrated use of multiple ICT artifacts and tools commonly used in existing educational practice, as is the case of those of the Web 2.0
3. Limited control for teachers of the degree of flexibility offered to students in the management of learning artifacts during the enactment	DR6. Enable teachers to define multiple kinds of constraints (regarding technological choices, contextual factors, arbitrary decisions, etc.) in order to regulate what students are able to do with learning artifacts

As we can see, no existing approach is fully without these three limitations, and thus **presents a challenge to the integration of across-spaces learning situations into existing teacher practice**. The following section describes the *learning bucket* notion and the system implementing it, which follows the aforementioned design requirements, aiming to overcome this challenge.

3 Learning Buckets

This section describes the learning bucket notion and the Bucket-Server, a system implementing such notion.

3.1 Learning Bucket notion

A *learning bucket* is a configurable container of learning artifacts, which are positionable in different physical and virtual spaces (e.g., web and physical spaces). A learning bucket is defined at design time, when it is also configured with *constraints*, i.e., the limitations about what is possible to do within it during the enactment (e.g., tools to use, possible positioning types for artifacts, etc.). A bucket can be initially empty, and be filled afterwards with learning artifacts (e.g., during the enactment by students). Also, learning artifacts could be included in the bucket at creation time (e.g., by the teacher). A learning bucket can be embedded in learning environments in different spaces (e.g., web VLEs, mobile AR clients, etc.). The teacher could decide at design time to reuse a bucket in the same or different environment and space and by the same or different actors. Figure 1 illustrates the learning bucket notion.

A teacher can include learning buckets (initially empty or with artifacts) in her design, assigning them, for instance, to different groups in different activities. The teacher could also configure what would be possible to do in the buckets, for example, what types of artifacts can be used, how the artifacts can be positioned, the number of artifacts that can be created, etc. The constraints limit the flexibility offered to students, so that what students are able to do is coherent with the pedagogical intention decided by the teacher in the design phase.

Afterwards, during the enactment of learning activities, teacher or students can add new learning artifacts, and position them.

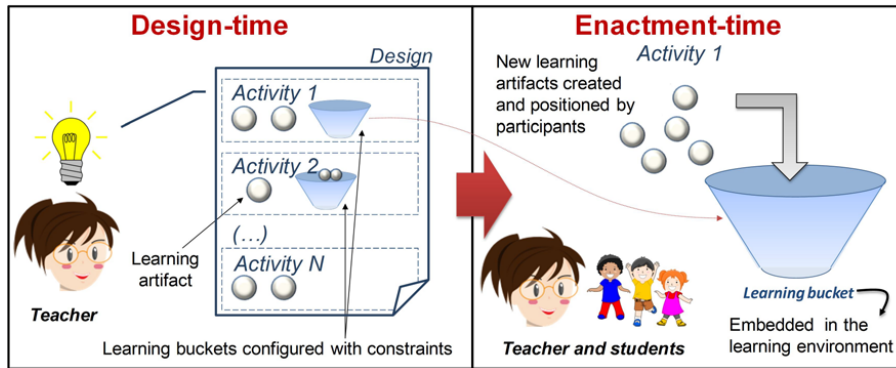

Figure 1. Learning bucket notion

Learning buckets allow students to take decisions with respect to the artifacts to use, always under the constraints imposed by the teacher. Thus, for instance, they could add new artifacts, within defined limits, they could position such artifacts with different methods (e.g., with geographical coordinates, with fiducial markers, etc.), and in different physical and virtual spaces (e.g., in a physical space using AR, in a web VLE), or they could select the type of artifact to use. The learning bucket could be also positioned in a space. The students, for instance, could access a bucket in a specific physical space (e.g., a park), and they could create from such space, using the bucket, different artifacts (e.g., documents and pictures), which could be automatically positioned where they are created, or manually positioned in another position and/or another space. Therefore, a learning bucket is an element that can convert a system not initially designed to conduct learning activities involving multiple spaces (e.g., a VLE such as Moodle), in an across-spaces system, making it possible to carry out learning situations in multiple physical and virtual spaces, and facilitating the transitions between spaces (making them seamless). In addition, the type of decisions that the students could take while creating and positioning learning artifacts using buckets could favor student-centered pedagogical approaches.

Figure 2 shows the conceptual model of a learning bucket. A bucket has attributes (general properties of the bucket) and constraints (properties of the bucket that define any kind of restriction about what is possible to do in it), and it contains a set of positioned learning artifacts. Any virtual resource could be an artifact, e.g., a document, a web page, a 3D model, a tool instance, or even another learning bucket.

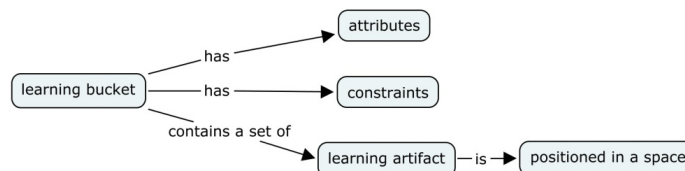

Figure 2. Learning bucket conceptual model

The learning bucket notion helps overcome the limitations indicated in Section 2:

1. Learning buckets and their artifacts can be positioned in multiple spaces (compliant with **DR1**), using different positioning types (**DR2**). Thus, a bucket not only supports across-spaces learning situations, but also, it can make existing learning environments (e.g., Moodle) capable of supporting across-spaces situations (even though they were not originally conceived for that). For instance, a bucket could be embedded in a specific activity assigned to a group of students in a Moodle course. Students could access the bucket, and create artifacts (e.g., quizzes in Google Docs documents), positioning them in a physical space. Such artifacts could be accessible in a subsequent activity, for other group of students, in the specific physical locations configured by the initial group of students, e.g., geographical coordinates of a park or fiducial markers in a museum, both using a mobile AR client (**DR3**).
2. A learning bucket is an element that can be embedded in different third party applications. So, it can be integrated into multiple types of applications for their educational use in different spaces (**DR4**): typical web VLEs, mobile AR clients, etc. In addition, a learning bucket supports the management (creation, deletion, positioning, etc.) of the multiple types of artifacts that can be included in a bucket (e.g., an implementation of the learning bucket notion could integrate artifacts of multiple widespread Web 2.0 tools) (**DR5**).
3. Teachers are able to control the degree of flexibility offered to students defining the constraints configurable in a learning bucket (**DR6**).

3.2 Bucket-Server: A learning buckets implementation

The Bucket-Server is a system implementing the concept of learning buckets. It allows the creation of buckets from within other software platforms (e.g., VLEs, mobile AR clients, etc.), and operations (create, modify, remove, retrieve) over them as well as over the learning artifacts contained in the buckets, through an API. Such artifacts can be, for example, instances of Web 2.0 tools (e.g., Google Docs or Picasa¹⁸), web resources (web pages, online documents), or other artifacts ideally accessible through and URI (e.g., a 3D model in an online repository).

3.2.1 Bucket-Server architecture

Figure 3 shows the architecture of the Bucket-Server. The *manager* is the central element, the controller of the system, responsible of managing learning buckets, their artifacts, storing the information (buckets and logs) in the persistent *data base* (DB), and providing an *API*, for the communication with external *applications* (e.g., VLEs such as Moodle, mobile AR clients such as Junaio¹⁹, etc.) (**DR4**). Such applications could use the API directly, or by means of an application *adapter*. Figure 4 (top) shows a summary of the API²⁰. The manager is also responsible of managing the artifacts of the buckets, communicating with the corresponding *artifact providers* through *adapters*. Such adapters standardize the operations of the manager over the different artifacts providers, so that the manager always uses the same set of

¹⁸ <http://picasa.google.com>. Last access April 2015

¹⁹ <http://www.junaio.com>. Last access April 2015

²⁰ The API is described in detail in Appendix B

operations, a contract²¹, independently of the API of each *artifact provider* (see a summary of such contract²² in Figure 4, bottom). An artifact provider could be, for instance, a Web 2.0 tool (e.g., Google Docs) (**DR5**). The Bucket-Server has also a *user interface* (UI), which acts as a client of the manager, using the API to interact with it. The UI allows the graphical operation over buckets and their artifacts independently of the learning environment in which they are embedded.

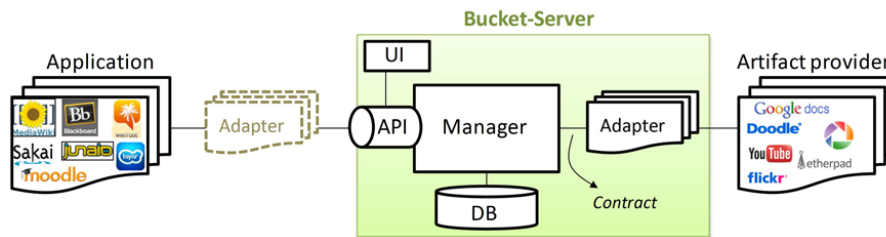

Figure 3. Bucket-Server architecture

GET	/artifactTypes
GET	/artifactTypes/{artifactType}/configuration
GET, POST	/buckets
GET, PUT, DELETE	/buckets/{bucketId}
GET, POST	/buckets/{bucketId}/artifacts
GET, PUT, DELETE	/buckets/{bucketId}/artifacts/{artifactId}
GET, POST, PUT, DELETE	/buckets/{bucketId}/artifacts/{artifactId}/toolinstance
GET, POST	/events

Summary of the Bucket-Server API

GET	/configuration
POST	/artifacts
GET, PUT, DELETE	/artifacts/{artifactId}

Summary of the artifact-provider adapter contract

Figure 4. Summaries of the Bucket-Server API (top) and the contract for artifact-provider adapters (bottom)

Figure 5 shows the data model implemented in the Bucket-Server. As the figure illustrates, a learning bucket is a container of learning artifacts. In order to enable the positioning and access of artifacts and buckets in different physical and virtual spaces (**DR1, DR3**), we have used the Point of Interest (POI) model, proposed in (Muñoz-Cristóbal, et al., 2014) after reviewing different systems and data models describing resources positioned in physical spaces. Such POI model is a selection, intended to be used in learning artifacts, of common attributes present in the different approaches explored. Thus, in the Bucket-Server data model, both artifacts and buckets are POIs, inheriting the POI's attributes (e.g., the attribute *positionType* which allows different positioning modes, **DR2**). An artifact can be of different types, corresponding to the artifacts providers integrated with the Bucket-Server (see Figure 3). The information element *ArtifactType* identifies the type of artifact, as well as its provider, and the configuration form necessary to configure its artifacts.

²¹ Therefore, the contract is the set of expected behaviors and APIs that the adapters needs to implement to communicate with the Bucket-Server manager (Ghiglione & Dalziel, 2007; Larman, 2001)

²² The contract is detailed in Appendix B

As the Figure 5 illustrates, a bucket has a set of attributes: the attributes inherited from the POI model, the *visibility* to enable the teacher to hide the bucket and its artifacts (e.g., in the sequence of activities of a VLE like Moodle), and the *author* (the user that created the bucket). Other attributes could be easily added to the data model. The bucket has also a set of constraints: special attributes focused on restricting what is possible to do in the bucket.

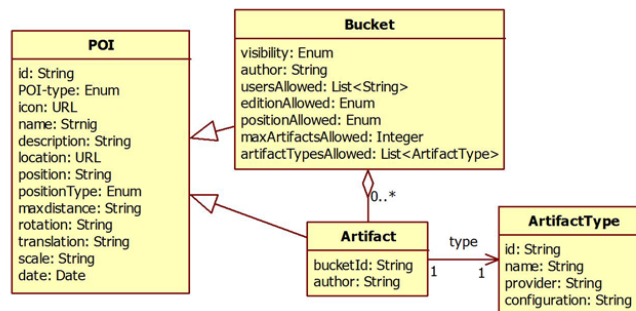

Figure 5. Data model implemented in the Bucket-Server

In order to facilitate the configuration of learning buckets to the teachers, and not overload the design phase, we have prioritized simplicity over completeness (although other constraints could be added to the model in the future with little effort). Thus, the current implementation of the data model supports the following constraints (classified according to the conceptualization of extrinsic constraints stated by Dillenbourg & Tchounikine, 2007, see Section 2.2) (DR6):

- Technological choices:
 - *artifactTypesAllowed*: Restrictions over the possible types of artifacts that can be used, among the set supported by the Bucket-Server installation.
- Contextual factors:
 - *positionAllowed*: Restrictions over the *positionType* POI attribute.
- Arbitrary decisions:
 - *usersAllowed*: Restrictions over the students allowed to access the bucket.
 - *editionAllowed*: Possible operations that the students can conduct with artifacts (e.g., create, remove, etc.).
 - *maxArtifactsAllowed*: Maximum number of artifacts that can be created in a bucket.

A learning bucket can be reused by the same or different applications, across multiple physical and virtual spaces, to achieve continuity in the different activities of a learning situation. Figure 6 shows an example of the use of a learning bucket. In the figure, the teacher creates a bucket at design time from within a VLE such as Moodle (web space), and configures the bucket with constraints to limit what students will be able to do. Thus, the teacher allows the students of *Groups 1* and *2* to create up to 6 artifacts in the bucket, of the types Google Docs and Google Slides. She also enables the students to geolocate the artifacts they create, and she does not allow students to delete artifacts. During the enactment, Group 1, using Moodle (Activity 1, web space) creates Google Docs and Google Slides with information

related to a type of tree present in a nearby park. They also position such artifacts in the location of the trees using geographical coordinates. In Activity 2, Group 2, using a mobile AR client such as Junaio at the park (physical space), access in the location of the aforementioned trees the artifacts created by Group 1 in the previous activity.

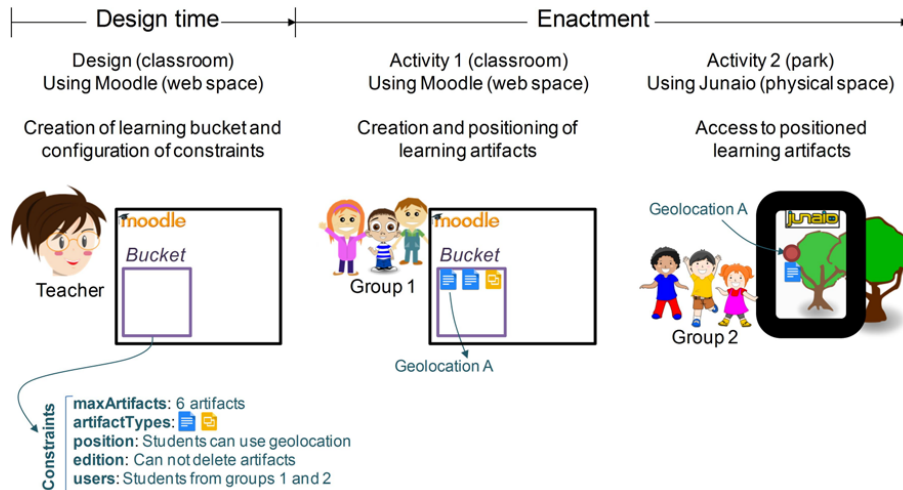

Figure 6. Example of the use of a learning bucket

3.2.2 Bucket-Server prototype

We have developed a Bucket-Server prototype aiming to explore the learning bucket notion and its use in across-spaces learning situations. The technologies used in the prototype are Java for the manager and the adapters, HTML and Javascript for the UI, and MySQL for the buckets database. The logs are stored in text files. We have created application adapters for the popular mobile AR browsers Junaio, Layar and Mixare (Grubert, Langlotz, & Grasset, 2011) as well as for any common QR code readers (*applications enabling learning activities in the physical space*). In addition, we have created an application adapter for the integration adapter²³ GLUE! (Alario-Hoyos et al., 2013), allowing the use of the VLEs currently integrated in GLUE! (Moodle and Mediawiki) (*applications enabling learning activities in the web space*), and other applications that are currently using GLUE!, such as GLUEPS-AR (Muñoz-Cristóbal, et al., 2014) (*across-spaces applications*). Finally, we have created also an adapter for the artifact provider GLUE!²⁴, enabling to include in the buckets all the artifact types supported by GLUE! (multiple Web 2.0 tools, widgets, etc.). Figure 7 illustrates the prototype developed. Figure 8 and Figure 9 show screenshots of the prototype UI.

²³ An integration adapter is an intermediary system that enables the integration of multiple tools with a single adapter (Alario-Hoyos & Wilson, 2010). We used GLUE! in the prototype in order to benefit from the existing GLUE! adapters, but any other integration adapter could be used.

²⁴ Notice that GLUE! is used as both a third party application (developing an application adaptor), and as an artifact provider (developing a artifact provider-adaptor). The first enables the integration of buckets in the VLEs supported by GLUE!, and the latter enables the inclusion in buckets of learning artifacts of the types supported by GLUE!.

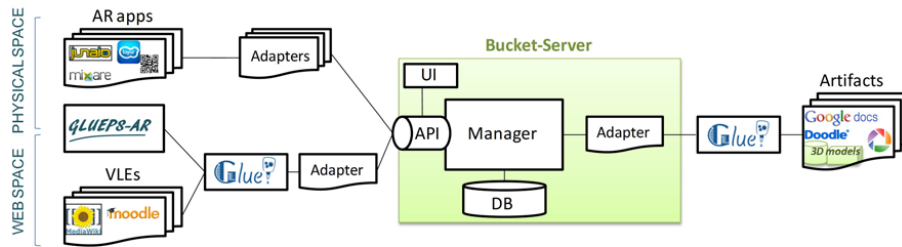

Figure 7. Bucket-Server prototype

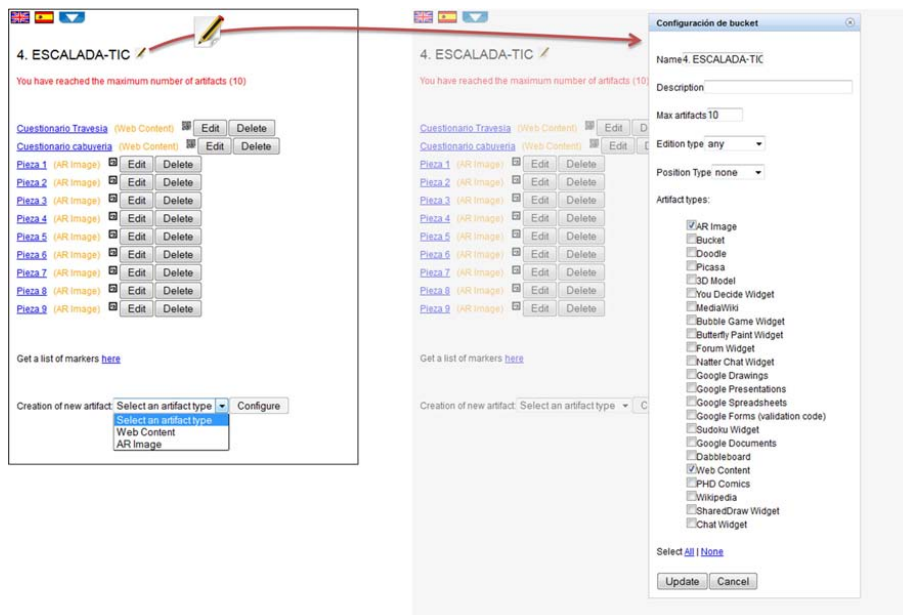

Figure 8. User interface of a bucket with artifacts positioned in QR codes and fiducial markers (left). Clicking in the bucket edition icon (notebook and pen), the bucket configuration window opens (right). The edition icon only appears if the user accessing the bucket is its author

Figure 10 shows the sequence diagram of the creation of a bucket and an artifact from a third party application, using the Bucket-Server API. An alternative to implement all the possible resources of the Bucket-Server API is embedding the UI of a bucket, so that such third party application would only need to implement a reduced set of resources of the Bucket-Server API (those necessary for creating and deleting a bucket). Figure 11 shows the sequence diagram of such alternative (see in Figure 13, Figure 15 and Figure 16 examples of learning buckets embedded in VLEs).

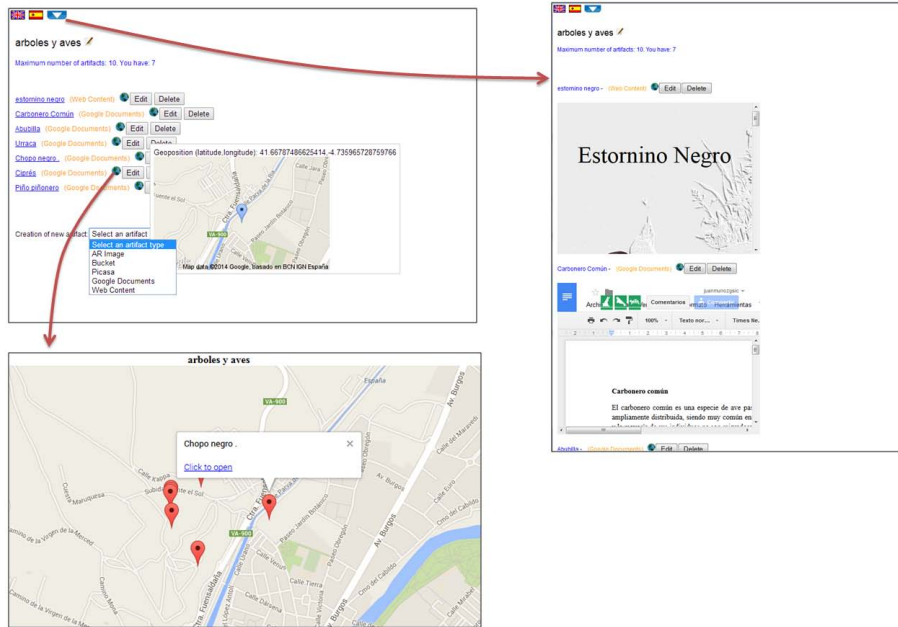

Figure 9. User interface of a bucket with geopositioned artifacts (top, left). Clicking in the "change view" icon, the bucket representation changes to a extended view, with the artifacts embedded (right). Clicking in the geoposition icon (a Earth globe), a map with the artifacts geopositioned appears (down)

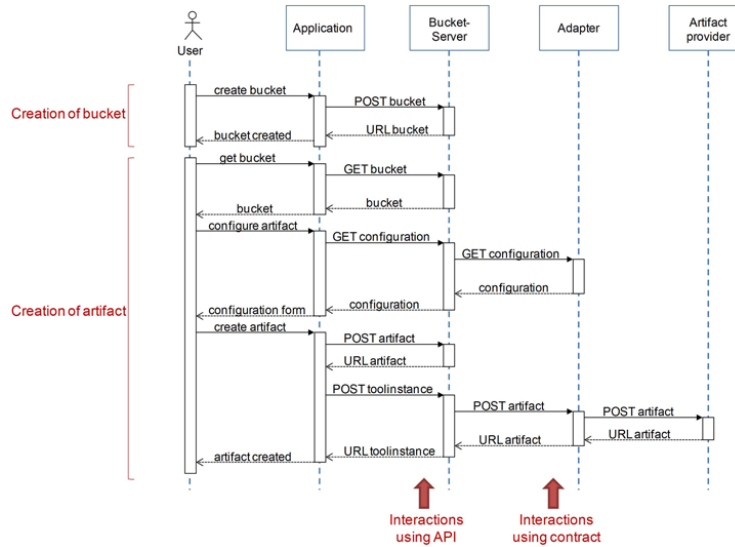

Figure 10. Sequence diagram of the creation of a bucket and an artifact from a third party application using the Bucket-Server API

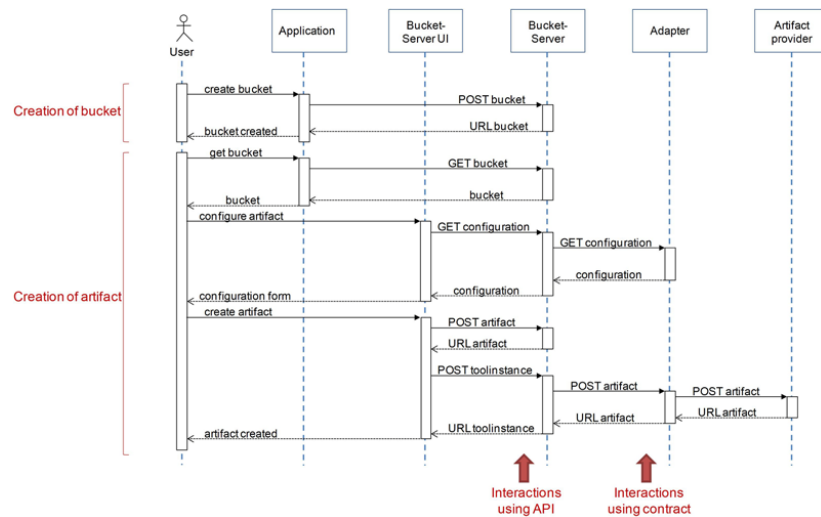

Figure 11. Sequence diagram of the creation of a bucket and an artifact from a third party application, using only a reduced set of resources of the Bucket-Server API, and embedding the Bucket-Server User Interface (UI) of the bucket

3.2.3 Integration of the Bucket-Server with third party applications

As mentioned, we have integrated the Bucket-Server prototype with different applications, in order to explore the support given by the system to the limitations described in Section 2. The following sections detail such integrations.

3.2.3.1 Integration with GLUEPS-AR

GLUEPS-AR (Muñoz-Cristóbal, et al., 2014) is an across-spaces orchestration system that enables the deployment (i.e., the setting up of the technological implementation for the enactment) in ULEs of learning designs that may be defined in different authoring tools. Such ULEs can be composed of web VLEs and mobile AR clients. Since GLUEPS-AR is based on a learning design approach, everything has to be predefined in the design (e.g., the learning artifacts to use during the enactment). Thus, the flexibility provided during the enactment is quite limited. The integration of learning buckets into GLUEPS-AR provides additional flexibility in the management of learning artifacts during the enactment. Hence, buckets can be embedded in the different environments, for instance in order to be used in a specific activity and by a group of students for creating geopositioned documents about a type of trees from within Moodle. Such bucket can be reused in a subsequent activity, in the same or another learning environment and by the same or another group of students, for instance for accessing such documents in a park at the configured location of the trees using an AR app. Figure 12 shows the integration carried out of GLUEPS-AR with the Bucket-Server. An interesting remark is that the installation of GLUE! used in GLUEPS-AR is the same as the installation of GLUE! used as artifact provider in the Bucket-Server.

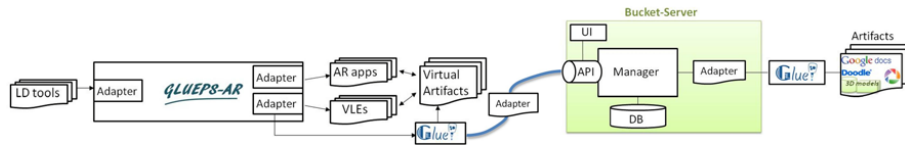

Figure 12. Integration of GLUEPS-AR with Bucket-Server

As the Figure 12 illustrates, the Bucket-Server is integrated with GLUEPS-AR by means of an adapter connected to the integration adapter GLUE!, currently used in the GLUEPS-AR prototype. Thus, learning buckets are used as any other virtual artifact in GLUEPS-AR, and they can be included at any point of the design, being reused in different activities, etc. Since GLUEPS-AR supports across-spaces learning situations, once the buckets are created, they can be deployed into the learning environments supported by GLUEPS-AR (VLEs and mobile AR clients). For example, in the case of a VLE such as Moodle, the bucket would be embedded in the corresponding course deployed by GLUEPS-AR. As GLUEPS-AR integrates multiple VLEs (Moodle, Mediawiki) and multiple mobile AR clients (Juniao, Layar, Mixare, QR code readers), learning buckets can be included in learning designs making use of all these applications. Thus, buckets and their artifacts can be positioned in different spaces (web and physical), and be accessed (buckets and artifacts) from different spaces and positioning types (e.g., fiducial markers, QR codes, geolocation).

Figure 13 shows screenshots of the bucket configuration form (where the teachers configures the bucket constraints) in GLUEPS-AR, and of the bucket embedded in a wiki-based VLE after the deployment with GLUEPS-AR.

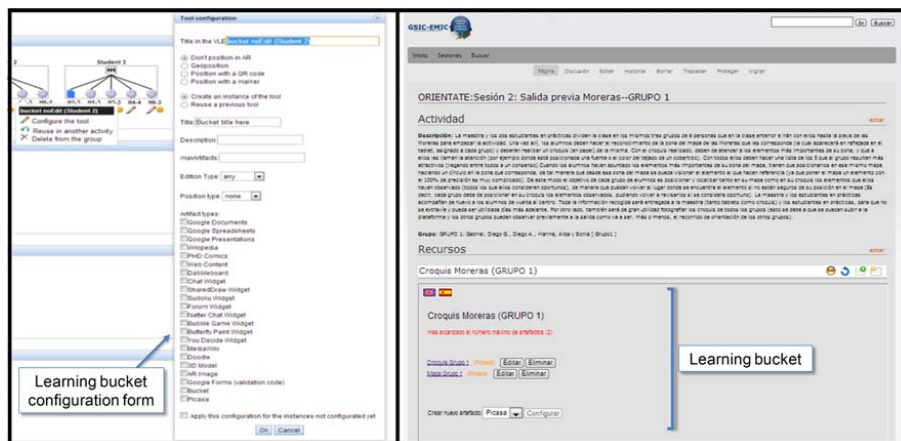

Figure 13. Bucket configuration form in GLUEPS-AR (left), and bucket embedded in a wiki-based VLE (right)

3.2.3.2 Integration with VLEs and mobile AR clients

The Bucket-Server can be integrated directly with third party applications already used in education, such as VLEs and mobile AR clients. Such integration enables to increase the flexibility offered to the students by such applications, as well as to connect them forming a VLE. We have integrated the Bucket-Server prototype with two VLEs (Moodle, and a

Mediawiki-based one) and four mobile AR clients (Junaio, Layar, Mixare, QR code readers). Figure 14 illustrates such integrations.

In the current prototype, the VLE acts as a central element of the learning situation, and buckets are created in the activities of the VLE, appearing embedded on it. In the AR applications, the user has to authenticate using the username of the VLE, and select a bucket (from the list of buckets where the user is a participant). Thus, the user is able to access the bucket's artifacts, which will be positioned where they were defined in the VLE (e.g., using geolocation, QR codes or fiducial markers in physical spaces). If one of the artifacts is a bucket, the user will be able to access it and create artifacts.

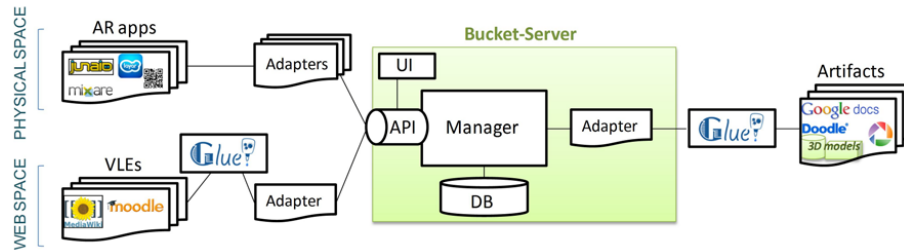

Figure 14. Integration of Bucket-Server with VLEs and mobile AR clients

Figure 15 shows a learning bucket created in Moodle (left), and a snapshot of the geopositioned learning artifacts of such bucket in the Junaio AR client (right). Figure 16 shows a second learning bucket created in Moodle with artifacts (pieces o a puzzle) positioned in markers, and how the puzzle is perceived with AR using Junaio.

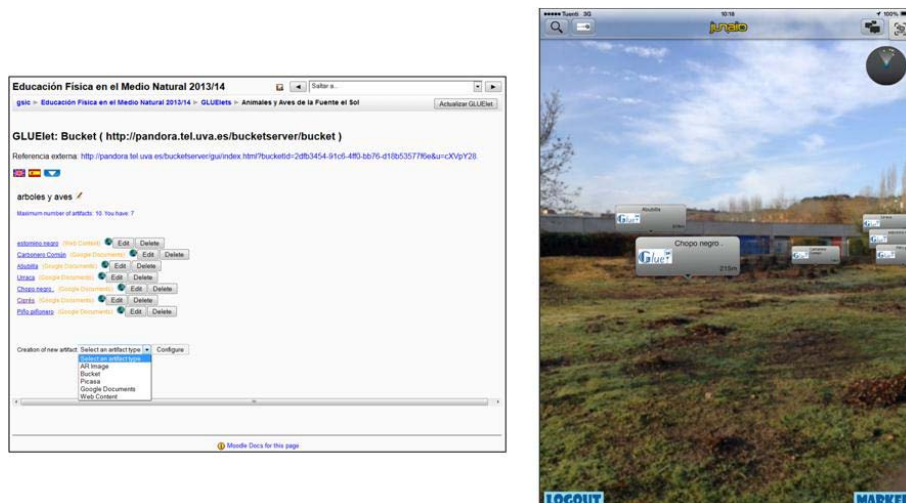

Figure 15. Learning bucket embedded in Moodle with geopositioned learning artifacts (left), and such artifacts in Junaio (right)

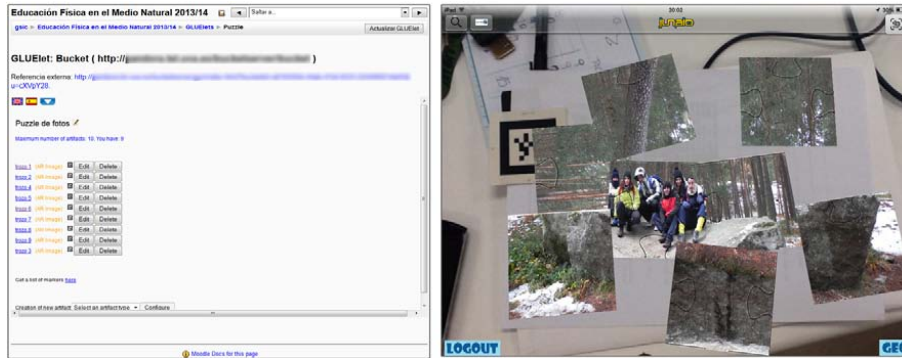

Figure 16. Learning bucket embedded in Moodle with artifacts positioned in markers (left) and such artifacts in Junaio (right)

4 Evaluation

We have carried out an evaluation to explore the research question that guides our work:

How can technology help introduce flexibility in the management of learning artifacts during the enactment of across-spaces learning situations, guided by the teachers' pedagogical decisions, and in a way that is integrated with current practice?

The evaluation consisted of (1) a pilot study where the evaluation team performed an across-spaces learning situation in a workshop with a group of lecturers and researchers experts in the across-spaces learning field; and (2) a feature analysis in which the evaluation team scored the support provided by the Bucket-Server and by alternative approaches in the literature, to the design requirements posed in Section 2, for the teacher-controlled flexible management of learning artifacts in across-spaces learning situations.

4.1 Method

For the evaluation, we have followed the Evaluand oriented Responsive Evaluation Model (EREM) (Jorrín-Abellán & Stake, 2009). The EREM is a framework based on a Responsive Evaluation approach (Stake, 2004), and it is conceived to guide evaluators of innovations in a wide range of ubiquitous and collaborative learning situations. This kind of evaluation is framed within an interpretive research paradigm (Cohen, Manion, & Morrison, 2007; Orlikowski & Baroudi, 1991), aiming to a deep understanding of the particularity and the richness of the concrete phenomena under study, instead of pursuing statistically-significant results.

To explore the research question we have carried out an anticipatory data reduction process (Miles & Huberman, 1994) during the evaluation design (see Figure 17). Thus, we defined an issue as the main conceptual organizer of the evaluation: *How do learning buckets help teachers introduce a controlled but flexible management of learning artifacts during the enactment of across-spaces learning situations that may involve technologies existing in current practice?* We divided such issue into two topics to be illuminated, and we used the Bucket-Server prototype to investigate the topics. The first topic focused on exploring how the

Bucket-Server provides *flexibility in the management of learning artifacts during the enactment of across-spaces learning situations*. Such topic was aimed to understand the general support of the Bucket-Server to the flexible management of learning artifacts during the enactment. The second topic centered on exploring the support provided by the Bucket-Server to the design requirements defined in Section 2, and therefore, on its *features for overcoming the limitations of current approaches that provide flexibility during enactment of learning situations*. Such topics were studied through a set of informative questions. The schema “research question – issue – topics – informative questions” (see Figure 17) also guided the data collection during the evaluation, which was carried out using a profuse set of data sources. Table 3 describes the different data gathering techniques employed, and their purpose in the evaluation process.

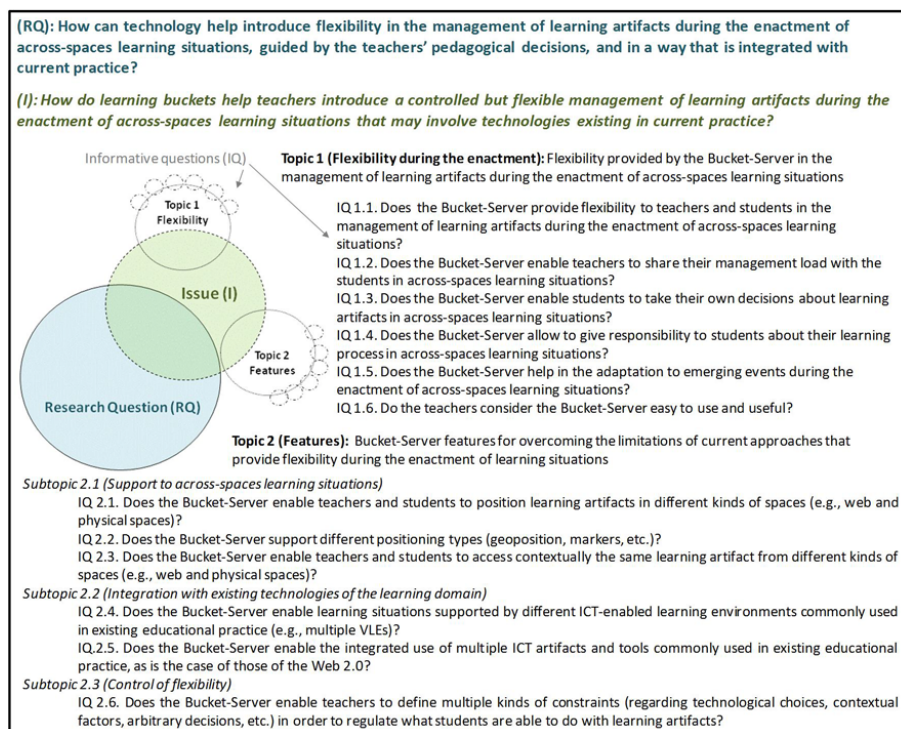

Figure 17. Anticipatory data reduction showing research question (RQ), issue (I), topics and informative questions (IQ)

Figure 18 illustrates the evaluation process followed, divided into happenings (evaluation events). It involved a pilot study (van Teijlingen & Hundley, 2002), i.e., a preliminary small study to obtain knowledge, experience and feedback from experts, as well as a feature analysis, i.e., a systematic comparison of the features of different approaches or systems. Through the pilot study we explored both topics (flexibility during the enactment and features), and the feature analysis focused on topic 2 (features). During the pilot study, different data gathering techniques and sources were used: naturalistic observations, web-based questionnaires, and collection of artifacts generated by the participants. The data

analysis was carried out with the NVivo²⁵ software, coding the data sources using the anticipatory data reduction schema (see Figure 17) as an initial category tree thus predetermining the initial set of codes to use a-priori (Miles & Huberman, 1994). We also performed a feature analysis to explore if support of learning buckets to the defined design requirements improves the support provided by other approaches in the literature. We followed the feature analysis screening method of the DESMET evaluation methodology (Kitchenham, Linkman, & Law, 1997). The screening method is a qualitative feature-based evaluation performed by a single individual or an evaluation team, who not only determines the features to be assessed and their rating scale but also does the assessment. Questionnaires (*score sheets*, see Figure 18) are used to assess the features, and the scores are summarized in a final report called *evaluation profile*.

During the evaluation, triangulation of methods, techniques and sources were used, to cross-check data as well as to assure the quality, credibility and rigor of the research and its results (Guba, 1981). The different data gathering techniques used in each happening are labeled in Figure 18 with the labels used all along the text to refer to them.

Table 3. Data gathering techniques

Technique	Type of data	Label
Collection of participants' generated artifacts	Collection of a diverse set of artifacts generated by the trainers (learning design, wiki pages/course, learning buckets, learning artifacts, pictures, emails) and the experts (learning artifacts, emails). Used to register the use of learning buckets, and to complement the observation with information of the learning artifacts generated.	[Art]
Observation	Audio/video recordings and observation notes taken during the workshop with the experts, to register their actions, impressions, and other emergent issues.	[Obs]
Questionnaires	Feedback questionnaires composed of open-ended and closed items regarding the use of buckets; and score sheets of the support provided by systems to a set of features. Used to collect the opinions of the experts and the evaluation team about the Bucket-Server.	[Quest] [Score]

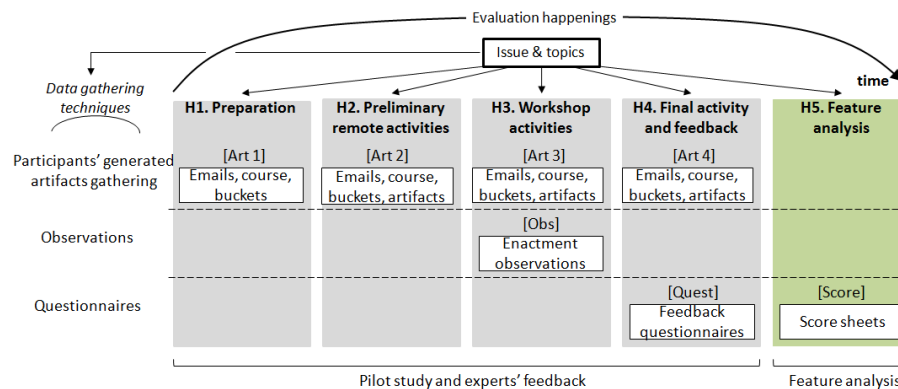

Figure 18. Evaluation happenings (H) and data gathering techniques used during the evaluation

²⁵ <http://www.qsrinternational.com/products.aspx>. Last access April 2015

4.2 Pilot study

4.2.1 Context

The study took place around a workshop (Madrid, May 2013) of a research project called *Educational Reflected Spaces*²⁶, related to learning across physical and virtual spaces and funded by the Spanish government (TIN2011-28308-C03-02). 26 lecturers and researchers from three Spanish universities (University of Valladolid, Pompeu Fabra University of Barcelona and Carlos III University of Madrid) participated in the workshop.

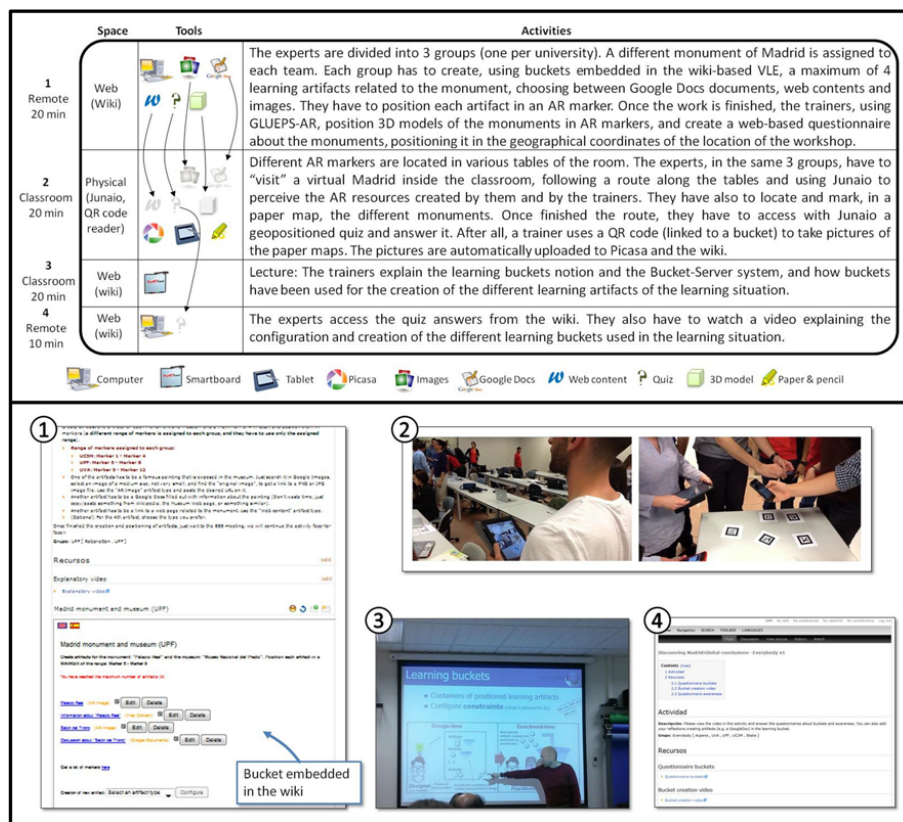

Figure 19. Virtual Madrid in the classroom using learning buckets. Description of the learning situation (top) and snapshots of the four activities (bottom)

4.2.2 Intervention

In order to explain and demonstrate the notion and system of learning buckets, two members of the evaluation team created, deployed (using GLUEPS-AR integrated with the Bucket-Server) and enacted an across-spaces learning situation consisting of activities before, during and after the workshop. The learning situation was aimed at the collaborative creation by the workshop participants, of a "virtual Madrid" inside the classroom, using learning buckets, in order to help them understand the notion of learning buckets and the Bucket-

²⁶ <http://eee.gast.it.uc3m.es>. Last access April 2015

Server system, as well as their affordances. Thus, the participants, remotely and previously to the workshop, used learning buckets embedded in a wiki-based VLE to create learning artifacts (using Web 2.0 tools, images and web contents) and position them in AR markers. Such artifacts were accessed in a subsequent activity during the workshop using the Junaio mobile AR client. Figure 19 describes the learning situation conducted.

4.2.3 Evaluation happenings

During the first happening (H1 in Figure 18), the trainers (two members of the evaluation team) designed and deployed the learning situation described in Figure 19 using the WebCollage authoring tool (Villasclaras-Fernández, Hernández-Leo, Asensio-Pérez, & Dimitriadis, 2013) and GLUEPS-AR integrated with the Bucket-Server. Thus, they created learning buckets using the GLUEPS-AR user interface, which were embedded in the wiki-based VLE used during the study. Then, the participants in the workshops were asked to conduct the remote activity previously to the workshop using the wiki-based VLE (H2). In the remote activity, the participants used learning buckets to create and position learning artifacts. The trainers monitored the artifacts created by the participants in the wiki, scaffolding them when needed. In a next happening during the workshop (H3), the participants conducted the face-to-face activities of the learning situation (see Figure 19). Such activities were observed (see Figure 18), gathering observation notes, and audio and video recordings from the session. Finally, the participants finalized remotely online the learning situation and gave feedback about the learning buckets through a web-based questionnaire (H4). Seven participants from the three universities answered the questionnaire, including experts in AR, blended learning, across-spaces learning and orchestration of learning situations.

4.2.4 Findings

This section describes the main findings obtained during the pilot study, organized following the anticipatory data reduction diagram (see Figure 17). Throughout the text, the data sources that support the different assertions are indicated with labels (see Figure 18) between square brackets. Due to space restrictions, only a selection of excerpts of the data sources is included in the text. It is important to emphasize that in accordance with the responsive evaluation approach followed, we do not aim at obtaining quantitative measurements or statistically significant results, but only to explore, and understand, the participants' impressions and feelings regarding the learning buckets.

4.2.4.1 Topic 1 (flexibility during the enactment)

This topic focuses on exploring the general support provided by the Bucket-Server to the flexible management of learning artifacts during the enactment of learning situations. Table 4 shows the type, positioning type and number of the buckets and buckets' artifacts created by the trainers and the participants during the different activities [Art 1-3]. The results of the evaluation were positive regarding the flexibility provided by the Bucket-Server in the management of learning artifacts during the enactment of across-spaces learning situations [Art 1-3, Quest]. In the questionnaire (as aforementioned, with an exploratory nature, and answered by 7 of the 26 participants), the experts recognized such flexibility provided by the learning buckets (see questions 1, 2 and 3 in Table 5 [Quest]). They also acknowledged that the Bucket-Server enables teachers to share their management load with the students. In the questionnaire, the participants agreed with the assertion regarding the management load (see

question 4 in Table 5 [Quest]), and some other comments of the experts relative to the benefits of the learning buckets confirm such view (“*It is interesting that the students themselves participate in the instantiation of a learning situation*”, “*buckets benefits includes the implication of the students in the activity, a meta-cognitive learning [...] and lightening the work of the teacher*” [Quest]). The experts acknowledged also that the Bucket-Server can aid in the adaptation when facing emerging events during the enactment of across-spaces learning situations (see question 5 in Table 5 [Quest]).

Table 4. Buckets and buckets’ artifacts created by trainers and participants [Art1-3]

Trainers			Participants		
Artifact type	Positioning type	No. artifacts	Artifact type	Positioning type	No. artifacts
Bucket	Web	3	Google Docs	Fiducial marker	2
Bucket	QR code	1	AR image	Fiducial marker	6
Picasa picture	Web	1	Web content	Fiducial marker	3

Evaluation evidence showed that the Bucket-Server enables students to take their own decisions about learning artifacts, allowing to give students responsibility about their learning process in across-spaces learning situations. During the enactment of the learning situation, the experts decided the artifacts to create choosing between different artifact types (Google Docs documents, web content and images) [Art1-2]. Also, results were very positive in the questionnaire regarding such decision-taking and responsibility-giving affordances of the Bucket-Server (see questions 6 and 7 in Table 5; it was also confirmed in some free-text answers, such as “*A benefit of learning buckets is that they allow to pass from teacher-centered approaches to student centered ones*” [Quest]).

Experts considered the Bucket-Server easy to use. Such easiness was perceived more clearly in their use by students than by teachers (see questions 8 and 9 in Table 5 [Quest]). One of the experts recommended the improvement of the Bucket-Server user interface: “*The interface to manipulate buckets is not very intuitive. For instance, to create an artifact, you have to go to the bottom, and it is not identified with any typical icon for creating something new*” [Quest].

The Bucket-Server was also considered useful by the experts. Thus, they considered useful the constraints configurable by teachers to restrict what students are able to do (see question 10 in Table 5 [Quest]). Experts agreed also with assertions regarding that buckets’ constraints allow teachers to keep control of what students do with buckets (see question 11 in Table 5 [Quest]), and regarding that such constraints are important to the subsequent management by the teacher of the artifacts created by students (see question 12 in Table 5 [Quest]). Some experts suggested the inclusion of additional constraints, such as temporal restrictions or related to social organization in the access to buckets. Some of the benefits of learning buckets observed by the experts (in addition to those already mentioned) were: the capability for the participation of students in the creation of learning artifacts with information for different spaces (which the participants recognized that could be also applicable to learning environments such as PLEs and MOOCs); being a generic container allowing the grouping of artifacts in both, design and enactment time; the collaboration of participants in-situ and participants in virtual environments; and the runtime awareness of what is occurring [Quest].

4.2.4.2 Topic 2 (Features)

All the features corresponding to the design requirements posed in Section 2 were supported during the learning situation. Thus, the Bucket-Server enabled trainers and experts to position learning artifacts in different spaces using different positioning types (see, e.g., Table 4 [Art1-3], and question 13 in Table 5 [Quest]). The trainers positioned a bucket in a QR code to upload pictures to Picasa, and such pictures were positioned only in the wiki. The experts positioned in fiducial markers the learning artifacts they created. An email from the trainer to one of the groups illustrates the positioning affordance: *"I see that you have created a couple of artifacts in the wiki [...], but they are not positioned correctly: One is positioned in a QR code and the other one is not positioned [in the physical space]. You should position them using markers (option 'Position in a marker') from the range you are assigned (Marker 5 to Marker 8)"* [Art 2]. Also, it was gathered in the questionnaire that *"I see clearly how to position resources in the physical world, but I don't see how to position them in the [3D] virtual world. In that case, it would be Virtual Reality instead of AR, but it would be very useful"* [Quest]. The learning artifacts created by trainers and experts were accessed subsequently from the wiki as well as from the physical classroom using AR (some observation notes and video annotations illustrate this: *"the group of the Pompeu Fabra University starts to see the artifacts", "the group of the Carlos III University is using Junaio and viewing with AR the artifacts: images, Google Docs documents, etc"* [Obs]). Finally, evidence gathered showed that the Bucket-Server allowed a continuity of the learning experience in activities performed in different physical and virtual spaces. During the learning situation, the experts created artifacts remotely online in a web-based VLE (the wiki), which were afterwards accessed from the physical classroom using AR. In addition, artifacts created from the physical classroom were subsequently accessed from the wiki (pictures from the paper-based maps taken by the trainer) [Art 2-4]. Results in the questionnaire were very positive regarding that the Bucket-Server enables such continuity (see question 14 in Table 5 [Quest]) as well as regarding that it allows to take advantage of using multiple physical and virtual spaces (see question 15 in Table 5 [Quest]). Also, one of the experts suggested modifying the user interface to include positioning types enabling the use of artifacts in 3D virtual world (3DVW) spaces [Quest].

Moreover, the Bucket-Server enabled the trainers and the experts the integrated use of multiple systems already existing in the educational domain [Art 1-4, Obs, Quest]: commonly used artifacts and tools, such as Web 2.0 tools (Google Docs documents, Picasa), different web contents and images; and different kind of learning environments such as a wiki-based VLE and the Junaio mobile AR client (*"the group of the Pompeu Fabra University is accessing with Junaio a Google Docs document [...] created by some of the groups and positioned in a marker"* [Obs]).

In addition, the Bucket-Server enabled the trainers to configure constraints for limiting what experts were able to do within buckets [Art 1-4, Quest]. These constraints were the maximum number of artifacts that could be created in the buckets; the permissions to create, update or delete artifacts; the available artifact types that the participants could use; and allowing the experts to position artifacts by themselves.

Table 5. Frequencies²⁷ of the answers to a selection of closed questions of the questionnaire used during the evaluation [Quest]

Questions	Answers frequencies					
	6= Strongly agree	5=Agree	4=Somewhat agree	3=Somewhat disagree	2=Disagree	1=Strongly disagree Don't know/no answer
1. I think that learning buckets provide flexibility in the management of learning artifacts (e.g., creating, updating , positioning them) during the enactment	2	3	2	0	0	0
2. I think that the learning buckets add flexibility in what the students can do during the enactment	3	4	0	0	0	0
3. I think that the learning buckets add flexibility in what the teachers can do during the enactment	3	1	2	0	0	1
4. I think that learning buckets enable the transference of part of the management load to the students (e.g., taking decisions about learning artifacts, creating/updating/removing artifacts, etc.)	3	1	3	0	0	0
5. The use of learning buckets can help in the adaptation to changes during the enactment	2	3	2	0	0	0
6. I think that the Bucket-Server allows the students to take some decisions regarding learning artifacts (e.g., what type of artifact to use, or where/when to create learning artifacts)	4	3	0	0	0	0
7. I think that the Bucket-Server allows to give responsibility to the students (by allowing them to take decisions about the learning artifacts)	4	3	0	0	0	0
8. I think that learning buckets are easy to use for non-ICT-experts students	1	5	1	0	0	0
9. I think that learning buckets are easy to use for non-ICT-experts teachers	1	2	3	1	0	0
10. I think that the constraints that the teacher can define in a learning bucket for limiting what the students can do in the bucket (types of artifacts, edition type, positioning type, maximum number of artifacts) are useful	2	3	2	0	0	0
11. I think that the constraints configurable in the learning buckets (types of artifacts, edition type, positioning type, maximum number of artifacts) allow to keep control of what can be done afterwards within them	2	3	2	0	0	0
12. Such constraints are important for the subsequent teacher management of the learning artifacts created by the students	3	3	0	0	0	1
13. I think that the Bucket-Server allows to take advantage of the geopositioning and the detection of markers capabilities that mobile devices implement to facilitate learning	4	1	2	0	0	0
14. I think that the Bucket-Server can allow continuity between the activities carried out in different physical and virtual spaces (classroom, playground, natural environment, web tools, wiki, Moodle, etc.)	5	1	1	0	0	0
15. I think that the Bucket-Server allows to take advantage of using multiple physical and virtual spaces	6	0	0	0	0	1

4.3 Feature analysis

A feature analysis was carried out by the evaluation team (composed of 5 researchers) in order to compare systematically the support provided by the Bucket-Server and by current approaches to the design requirements indicated in Table 2 (topic 2, see Figure 17). It is important to note that the feature analysis does not outline the general characteristics or quality of the approaches. It is specifically focused on the systematic comparison of the indicated features, and it is not valid for anything else.

²⁷ Number of participants who responded each point of the scale

Table 6. Evaluation profile of the different approaches

Features	Conformance score obtained										
	(Cahill, et al., 2010)	(Casquero, et al., 2010)	(Conde, et al., 2014)	(Giemza, et al., 2010)	(Griffiths, et al., 2012)	(Mikroyannidis, et al., 2013)	(Mulholland, et al., 2012)	(Simon, et al., 2013)	(Vogel, et al., 2010)	(Zhang, et al., 2010)	Bucket-Server
DR1. Enable teachers and students to position learning artifacts in different kinds of spaces (e.g., web and physical spaces)	1	0	0	4	0	1	4	2	4	0	5
DR2. Support different positioning types (geoposition, markers, etc.)	0	0	0	0	0	0	0	0	0	0	5
DR3. Enable teachers and students to access contextually the same learning artifact from different kinds of spaces (e.g., web and physical spaces)	0	0	0	4	0	1	4	1	2	1	5
DR4. Enable learning situations supported by different ICT-enabled learning environments commonly used in existing educational practice (e.g., multiple VLEs)	0	5	5	0	5	0	0	3	0	0	5
DR5. Enable the integrated use of multiple ICT artifacts and tools commonly used in existing educational practice, as is the case of those of the Web 2.0	0	4	4	0	4	4	0	4	3	4	4
DR6. Enable teachers to define multiple kinds of constraints (regarding technological choices, contextual factors, arbitrary decisions, etc.) in order to regulate what students are able to do with learning artifacts	2	2	3	4	2	4	4	2	0	4	4
Total	3	11	12	12	11	10	12	12	9	9	28
% over the total possible	10	36,67	40	40	36,67	33,33	40	40	30	30	93,33

Each member of the evaluation team scored (in a 0-5 scale), using score sheets [Score] as recommended by Kitchenham, et al. (1997), the support of different systems to the design requirements. Each evaluator rated at least two approaches in addition to the Bucket-Server. Only those approaches mentioned in Section 2 consisting in technological implementations which, as far as we know, overcome at least two of the three limitations identified in such section (see Table 1), were scored. Thus, theoretical proposals or specifications were not included in the feature analysis. For being able to score an approach, the evaluators studied the related publications and manuals, and tested the tools if they were accessible. Finally, the evaluation team, jointly in a 3-hours panel, shared the score sheets, discussed conflicting criteria, and generated an evaluation profile agreeing a final score for each approach. Table 6 shows such evaluation profile. The Bucket-Server was the system with the highest score, and the only one supporting all the features. The next scored systems were iTEC Composer (Simon, et al., 2013), nQuire (Mulholland, et al., 2012), the iPLE proposed by Conde, et al. (2014), and Lemonade (Giemza, et al., 2010). Lemonade and nQuire showed to be affected by the limitations about the integration of existing technologies in the educational practice, and the iPLE proposed by Conde, et al. (2014) showed a restricted support to across-spaces learning situations. iTEC Composer presented limitations in the support to across-spaces learning situations and in the regulation of the flexibility offered to the students. It is interesting to observe that the across-spaces dimension of the buckets (features DR1 to DR3) differentiates them from almost all the approaches, specially the possibility of using different positioning

types, which enables not being tied to a specific kind of space (e.g., to outdoors using GPS). Another aspect that emerged from the analysis was that almost all the systems implement certain capability for teachers to regulate what the students can do with learning artifacts. However, only five systems (including the Bucket-Server) include different types of configurable constraints regarding, e.g., technological choices, contextual factors or arbitrary decisions.

5 Conclusions

The evidence gathered in the evaluation suggests that the Bucket-Server, and therefore the learning buckets, can provide a teacher-controlled flexibility in the management of learning artifacts during the enactment of across-spaces learning situations that are not isolated from the teachers current practice. Thus, the learning buckets allow to configure different types of constraints regarding technological choices, contextual factors and arbitrary decisions to control the freedom of the students during the enactment. Also, the learning buckets showed a better support to across-spaces learning situations than the support provided by alternative approaches. In addition, the learning buckets enable the integrated across-spaces use of widespread tools, such as a wiki, Google Docs or Picasa. Moreover, evaluation evidence suggests that learning buckets enable students to participate in the instantiation of the learning situations, and can be an interesting instrument to evolve from teacher-centered approaches to student-centered ones.

Such flexibility can be especially important in approaches which are inherently rigid in what students are able to do during the enactment, as is the case of some learning design proposals. As an example, an across-spaces system based on learning design like GLUEPS-AR, was limited in the flexibility offered to teachers and students during the enactment of learning situations. By using learning buckets, as illustrated during the evaluation, GLUEPS-AR was enhanced, being provided with a teacher-controlled flexibility to enable teachers and students manage their learning artifacts across-spaces. However, the use of an approach based on learning design, such as GLUEPS-AR may add complexity to the setting up of the learning situations, because it requires the use of two additional tools (the authoring tool and GLUEPS-AR). Therefore, we plan to explore in the future the direct integration of the Bucket-Server with learning environments such as widespread VLEs. Such integration could convert a learning environment not natively supporting across-spaces learning situations (e.g., Moodle), in a system where teachers and students create across-spaces contents (e.g., resources to be used in subsequent activities in other spaces different to the web one of Moodle). We plan further research for exploring such possibility. Also, some of the possible enhancements detected during the evaluation should be explored in the future, such as the possible integration of 3DVWs and the improvement of the user interface.

Regarding the constraints, although we defined a simple set of constraints in the data model of the Bucket-Server, it could be extended, adding the complexity required for enabling more complex regulation of the degree of flexibility. We considered that a simple set was the best way to start exploring the concept, but future research could focus specifically in the possible constraints that could be configured, as pointed by some of the participants in the evaluation. In addition, the current prototype has the limitation of considering the VLE as a central

element. This allowed us to simplify the implementation, focusing in our research question. But it introduced a limitation that has to be tackled in the future, which is to devise a technological solution for global authentication (i.e., single sign on mechanisms), not depending on the VLE credentials (thus, supporting a totally distributed set of learning environments). In relation with this issue, security and privacy are two important matters that should be also further developed in future studies.

In order to explore in depth the help provided by the learning buckets to teachers in their real practice, we plan to continue our research by using the Bucket-Server in authentic learning situations with teachers and students. We also plan to explore how the Bucket-Server could provide support for reusing learning artifacts in different buckets and in different positions and spaces. Such reuse would extend the possible range of across-spaces learning situations that teachers could create with learning buckets. It could also enable the reuse of learning buckets and their artifacts out of the scope of the learning situations in which they are created, e.g., following a similar approach than the learning object repositories (Neven & Duval, 2002).

References

- Alario-Hoyos, C., Bote-Lorenzo, M. L., Gómez-Sánchez, E., Asensio-Pérez, J. I., Vega-Gorgojo, G., & Ruiz-Calleja, A. (2013). GLUE!: An architecture for the integration of external tools in Virtual Learning Environments. *Computers & Education, 60*(1), 122-137.
- Alario-Hoyos, C., & Wilson, S. (2010, November). *Comparison of the main alternatives to the integration of external tools in different platforms*. Paper presented at the Proceedings of the International Conference of Education, Research and Innovation, ICERI 2010, Madrid, Spain.
- Billinghurst, M., & Duenser, A. (2012). Augmented Reality in the classroom. *Computer, 45*(7), 56-63.
- Billinghurst, M., & Kato, H. (1999). *Collaborative Mixed Reality*. Paper presented at the Proceedings of International Symposium on Mixed Reality (ISMR '99). Mixed Reality--Merging Real and Virtual Worlds, Yokohama, Japan.
- Bogdanov, E. (2013). *Widgets and Spaces: Personal & Contextual Portability and Plasticity with OpenSocial*. Unpublished Ph.D. Thesis, École polytechnique fédérale de Lausanne.
- Cahill, C., Kuhn, A., Schmoll, S., Pompe, A., & Quintana, C. (2010, June). *Zydeco: Using Mobile and Web Technologies to Support Seamless Inquiry Between Museum and School Contexts*. Paper presented at the Proceedings of the 9th International Conference on Interaction Design and Children, Barcelona, Spain.
- Casquero, O., Portillo, J., Ovelar, R., Benito, M., & Romo, J. (2010). iPLE Network: an integrated eLearning 2.0 architecture from a university's perspective. *Interactive Learning Environments, 18*(3), 293-308.
- Clark, B., & Booth, A. (2006, October). SOCKET and the WAFFLE Bus for Beginners. Retrieved April 2015, from <http://www.elearning.ac.uk/features/socket.html>
- Cohen, L., Manion, L., & Morrison, K. (2007). *Research methods in education*. Abingdon, UK: Routledge.
- Conde, M. Á., García-Peñalvo, F., Alier, M., Mayol, E., & Fernández-Llamas, C. (2014). Implementation and design of a service-based framework to integrate personal and institutional learning environments. *Science of Computer Programming, 88*, 41-53.
- Conole, G., & Alevizou, P. (2010). *A literature review of the use of Web 2.0 tools in Higher Education* (A report commissioned by the Higher Education Academy): The Open University.

- Cope, B., & Kalantzis, M. (2010). Ubiquitous Learning: An Agenda for Educational Transformation. In B. Cope & M. Kalantzis (Eds.), *Ubiquitous Learning* (pp. 3-14): University of Illinois Press.
- Cuendet, S., Bonnard, Q., Do-Lenh, S., & Dillenbourg, P. (2013). Designing augmented reality for the classroom. *Computers & Education*, 68, 557-569.
- Chan, T.-W., Roschelle, J., Hsi, S., Kinshuk, K., Sharples, M., Brown, T., et al. (2006). One-to-one Technology-Enhanced Learning: An opportunity for global research collaboration. *Research and Practice in Technology Enhanced Learning*, 1(1), 3-29.
- de-la-Fuente-Valentín, L., Leony, D., Pardo, A., & Delgado Kloos, C. (2008, September). *Mashups in Learning Design: pushing the flexibility envelope*. Paper presented at the 1st Workshop MUPPLE'08, Maastricht, The Netherlands.
- De Jong, T., Van Joolingen, W. R., Giemza, A., Girault, I., Hoppe, U., Kindermann, J., et al. (2010). Learning by creating and exchanging objects: The SCY experience. *British Journal of Educational Technology*, 41(6), 909-921.
- Dillenbourg, P. (2002). Over-scripting CSCL: The risks of blending collaborative learning with instructional design. In P. A. Kirschner (Ed.), *Three worlds of CSCL. Can we support CSCL?* (pp. 61-91): Heerlen, Open Universiteit Nederland.
- Dillenbourg, P., & Tchounikine, P. (2007). Flexibility in macro-scripts for computer-supported collaborative learning. *Journal of Computer Assisted Learning*, 23(1), 1-13.
- Dragon, T., Mavrikis, M., McLaren, B. M., Harrer, A., Kynigos, C., Wegerif, R., et al. (2013). Metafora: A Web-Based Platform for Learning to Learn Together in Science and Mathematics. *IEEE Transactions on Learning Technologies*, 6(3), 197-207.
- Dyson, L. E., Litchfield, A., Lawrence, E., Raban, R., & Leijdekkers, P. (2009). Advancing the m-learning research agenda for active, experiential learning: Four case studies. *Australasian Journal of Educational Technology*, 25(2), 250-267.
- FitzGerald, E. (2013, June). *Situ8: browsing and capturing geolocated user-created content*. Paper presented at the Proceedings of the CALRG Annual Conference 2013, The Open University, Milton Keynes, UK.
- Ghiglione, E., & Dalziel, J. (2007, June). *Design Principles for LAMS Version 2 and the LAMS "ToolsContract"*. Paper presented at the TENCompetence Open Workshop on Current research on IMS Learning Design and Lifelong Competence Development Infrastructures, Barcelona, Spain.
- Giemza, A., Bollen, L., Seydel, P., Overhagen, A., & Hoppe, H. U. (2010, April). *LEMONADE: A Flexible Authoring Tool for Integrated Mobile Learning Scenarios*. Paper presented at the 6th IEEE International Conference on Wireless, Mobile and Ubiquitous Technologies in Education (WMUTE), Kaohsiung, Taiwan.
- Griffiths, D., Johnson, M., Popat, K., Sharples, P., & Wilson, S. (2012). The Wookie Widget Server: a Case Study of Piecemeal Integration of Tools and Services. *Journal of Universal Computer Science*, 18(11), 1432-1453.
- Grubert, J., Langlotz, T., & Grasset, R. (2011). *Augmented Reality Browser Survey* (Technical Report No. ICG-TR-1101): Institute for Computer Graphics and Vision, Graz University of Technology, Austria.
- Guba, E. G. (1981). Criteria for assessing the trustworthiness of naturalistic inquiries. *Educational Communication and Technology Journal*, 29(2), 75-91.
- Hannafin, M. J., & Land, S. M. (1997). The foundations and assumptions of technology-enhanced student-centered learning environments. *Instructional Science*, 25, 167-202.
- Hansen, F. A., & Bouvin, N. O. (2009). Mobile Learning in Context ? Context-aware Hypermedia in the Wild. *International Journal of Interactive Mobile Technologies*, 3(1), 6-21.
- Harrer, A., Pfahler, K., & Lingnau, A. (2013, July). *Planning for Life - Educate Students to Plan: Syntactic and Semantic Support of Planning Activities with a Visual Language*. Paper presented at the IEEE 13th International Conference on Advanced Learning Technologies (ICALT), Beijing, China.

- Herodotou, C., Villasclaras-Fernández, E. D., & Sharples, M. (2014, September). *The Design and Evaluation of a Sensor-Based Mobile Application for Citizen Inquiry Science Investigations*. Paper presented at the Proceedings of the 9th European Conference on Technology Enhanced Learning (EC-TEL), Graz, Austria.
- IMS Global Learning Consortium. (2003, January). IMS Learning Design information model. Retrieved November 10, 2013, from http://www.imsglobal.org/learningdesign/ldv1p0/imslid_infov1p0.html
- Jorrín-Abellán, I. M., & Stake, R. E. (2009). Does Ubiquitous Learning Call for Ubiquitous Forms of Formal Evaluation? An Evaluand Oriented Responsive Evaluation Model. *Ubiquitous Learning: An International Journal*, 1(3), 71-82.
- Keller, C. (2005). Virtual learning environments: Three implementation perspectives. *Learning, Media and Technology*, 30(3), 299-311.
- Kitchenham, B., Linkman, S., & Law, D. (1997). DESMET: A methodology for evaluating software engineering methods and tools. *Computing Control Engineering Journal*, 8(3), 120-126.
- Klopper, E., Sheldon, J., Perry, J., Rosenheck, L., Squire, K., Mathews, J., et al. (2011, July). *Augmented reality games: place-based digital learning*. Paper presented at the Proceedings of the 9th International CSCL Conference, Hong Kong, China.
- Koper, R. (2005). An introduction to learning design. In R. Koper & C. Tattersall (Eds.), *Learning Design. A Handbook on Modelling and Delivering Networked Education and Training* (pp. 3-20): Springer.
- Larman, C. (2001). *Applying UML and Patterns: An Introduction to Object-Oriented Analysis and Design and the Unified Process* (2nd ed.). Upper Saddle River, NJ, USA: Prentice Hall PTR.
- Laurillard, D., Charlton, P., Craft, B., Dimakopoulos, D., Ljubojevic, D., Magoulas, G., et al. (2013). A constructionist learning environment for teachers to model learning designs. *Journal of Computer Assisted Learning*, 29(1), 15-30.
- Li, L., Zheng, Y., Ogata, H., & Yano, Y. (2004, September). *A framework of ubiquitous learning environment*. Paper presented at the The Fourth International Conference on Computer and Information Technology (CIT 2004), Wuhan, China.
- Linn, M. C., Clark, D., & Slotta, J. D. (2003). WISE design for knowledge integration. *Science Education*, 87(4), 517-538.
- Martel, C., Vignollet, L., Ferraris, C., David, J.-P., & Lejeune, A. (2006, July). *Modeling Collaborative Learning Activities on e-Learning Platforms*. Paper presented at the Sixth International Conference on Advanced Learning Technologies (ICALT), Kerkrade, The Netherlands.
- Miao, Y., Hoeksema, K., Hoppe, H. U., & Harrer, A. (2005, May-June). *CSCL Scripts: Modelling Features and Potential Use*. Paper presented at the Proceedings of the International Conference on Computer Supported Collaborative Learning (CSCL), Taipei, Taiwan.
- Mikroyannidis, A., Okada, A., Scott, P., Rusman, E., Specht, M., Stefanov, K., et al. (2013). weSPOT: A Personal and Social Approach to Inquiry-Based Learning. *Journal of Universal Computer Science*, 19(14), 2093-2111.
- Miles, M. B., & Huberman, A. M. (1994). *Qualitative data analysis. An expanded sourcebook*. Thousand Oaks, California, USA: SAGE Publications Inc.
- Milrad, M., Wong, L.-H., Sharples, M., Hwang, G.-J., Looi, C.-K., & Ogata, H. (2013). Seamless learning: an international perspective on next-generation technology-enhanced learning. In Z. L. Berge & L. Y. Muilenburg (Eds.), *Handbook of Mobile Learning* (pp. 95-108). Abingdon: Routledge.
- Mulholland, P., Anastopoulou, S., Collins, T., Feisst, M., Gaved, M., Kerawalla, L., et al. (2012). nQuire: Technological Support for Personal Inquiry Learning. *IEEE Transactions on Learning Technologies*, 5(2), 157-169.

- Muñoz-Cristóbal, J. A., Prieto, L. P., Asensio-Pérez, J. I., Martínez-Monés, A., Jorrín-Abellán, I. M., & Dimitriadis, Y. (2014). Deploying learning designs across physical and web spaces: Making pervasive learning affordable for teachers. *Pervasive and Mobile Computing*, 14, 31-46.
- Neven, F., & Duval, E. (2002, December). *Reusable Learning Objects: A Survey of LOM-based Repositories*. Paper presented at the Proceedings of the Tenth ACM International Conference on Multimedia, Juan les Pins, France.
- Olivier, B., & Liber, O. (2001). *Lifelong Learning: The Need for Portable Personal Learning Environments and Supporting Interoperability Standards*: Bristol: The JISC Centre for Educational Technology Interoperability Standards, Bolton Institute.
- Orlikowski, W. J., & Baroudi, J. J. (1991). Studying information technology in organizations: Research approaches and assumptions. *Information Systems Research*, 2(1), 1-28.
- Pérez-Sanagustín, M., Martínez, A., & Delgado Kloos, C. (2012). EtiquetAR: a Tool for Designing Tag-based Mobile Augmented Reality Experiences. *Bulletin of the IEEE Technical Committee on Learning Technology*, 14(4), 27-30.
- Peter, Y., Villasclaras-Fernández, E. D., & Dimitriadis, Y. (2013, July). *ThirdSpace: orchestrating collaborative activities in PLEs for formal learning*. Paper presented at the Personal Learning Environment Conference, Berlin, Germany.
- Prieto, L. P., Muñoz-Cristóbal, J. A., Dimitriadis, Y., & Asensio-Pérez, J. I. (2013, June). *Flexible CSCL scripting using paper, generic Augmented Reality browsers and GLUEPS-AR*. Paper presented at the Workshop on Human-Computer Interaction and the Learning Sciences, 10th International Conference on Computer Supported Collaborative Learning (CSCL 2013), University of Wisconsin - Madison, USA.
- Prieto, L. P., Wen, Y., Caballero, D., & Dillenbourg, P. (2014). Review of Augmented Paper Systems in Education: An Orchestration Perspective. *Journal of Educational Technology & Society*, 17(4), 169-185.
- Rahimi, E., van den Berg, J., & Veen, W. (2012). *Designing and Implementing PLEs in a Secondary School Using Web2.0 Tools*. Paper presented at the Proceedings of the PLE Conference 2012, Melbourne, Australia.
- Santos, P., Pérez-Sanagustín, M., Hernández-Leo, D., & Blat, J. (2011). QuesTInSitu: From tests to routes for assessment in situ activities. *Computers & Education*, 57(4), 2517-2534.
- Santos, P., Pérez-Sanagustín, M., Hernández-Leo, D., & Blat, J. (2012, July). *Space-aware Design Factors for Located Learning Activities Supported with Smart Phones*. Paper presented at the IEEE 10th International Symposium on Parallel and Distributed Processing with Applications (ISPA), Madrid, Spain.
- Schaffert, S., & Hilzensauer, W. (2008). On the way towards Personal Learning Environments: Seven crucial aspects. *eLearning Papers*, 9. Retrieved from <http://openeducationeuropa.eu/en/download/file/19381>
- Seol, S., Sharp, A., & Kim, P. (2011, July). *Stanford Mobile Inquiry-based Learning Environment (SMILE): Using Mobile Phones to Promote Student Inquires in the Elementary Classroom*. Paper presented at the The 2011 World Congress in Computer Science, Computer Engineering, and Applied Computing, Las Vegas, Nevada, USA.
- Sharples, M. (2013). Shared orchestration within and beyond the classroom. *Computers & Education*, 69, 504-506.
- Sharples, M., Sanchez, I. A., Milrad, M., & Vavoula, G. (2009). Mobile learning: Small devices, big issues. In N. Balacheff, S. Ludvigsen, T. de Jong & S. Barnes (Eds.), *Technology Enhanced Learning: Principles and Products* (pp. 233-249). Heidelberg, Germany: Springer.
- Simon, B., Aram, M., Assche, F., Anido Rifon, L., Griffiths, D., & Rodríguez, M. (2013, September). *Applying the Widget Paradigm to Learning Design: Towards a New Level of User Adoption*. Paper presented at the 8th European Conference on Technology Enhanced Learning (EC-TEL 2013), Paphos, Cyprus.

- Stake, R. E. (2004). *Standards-based and responsive evaluation*. Thousand Oaks, CA, USA: SAGE Publications Inc.
- Torres Kompen, R., Edirisingha, P., & Mobbs, R. (2008, October). *Building Web 2.0-based personal learning environments - a conceptual framework*. Paper presented at the EDEN Research Workshop, Paris, France.
- van Teijlingen, E. R., & Hundley, V. (2002). The importance of pilot studies. *Nursing Standard*, 16(40), 33-36.
- Vavoula, G., Sharples, M., Rudman, P., Meek, J., & Lonsdale, P. (2009). Myartspace: Design and evaluation of support for learning with multimedia phones between classrooms and museums. *Computers & Education*, 53(2), 286-299.
- Villasclaras-Fernández, E., Hernández-Leo, D., Asensio-Pérez, J. I., & Dimitriadis, Y. (2013). Web Collage: An implementation of support for assessment design in CSCL macro-scripts. *Computers & Education*, 67, 79-97.
- Villasclaras-Fernandez, E. D., Sharples, M., Kelley, S., & Scanlon, E. (2013). *Supporting Citizen Inquiry: An Investigation of Moon Rock*. Paper presented at the Proceedings of the Eighth European Conference on Technology Enhanced Learning (EC-TEL), Paphos, Cyprus.
- Vogel, B., Spikol, D., Kurti, A., & Milrad, M. (2010, April). *Integrating Mobile, Web and Sensory Technologies to Support Inquiry-Based Science Learning*. Paper presented at the 6th IEEE International Conference on Wireless, Mobile and Ubiquitous Technologies in Education (WMUTE).
- Weinberger, A., Kollar, I., Dimitriadis, Y., Mäkitalo-Siegl, K., & Fischer, F. (2009). Computer-Supported Collaboration Scripts. In N. Balacheff, S. Ludvigsen, T. de Jong, A. Lazonder & S. Barnes (Eds.), *Technology-Enhanced Learning* (pp. 155-173): Springer Netherlands.
- White, S., & Davis, H. C. (2011, July). *Rich and personal revisited: translating ambitions for an institutional personal learning environment into a reality*. Paper presented at the The Second International PLE Conference, Southampton, UK.
- Wild, F., Mödritscher, F., & Sigurdarson, S. (2008). Designing for change: mash-up personal learning environments. *eLearning Papers*, 9. Retrieved from <http://openeducationeuropa.eu/en/download/file/fid/19383>
- Wilson, S., Liber, O., Johnson, M., Beauvoir, P., Sharples, P., & Milligan, C. (2007). Personal Learning Environments: Challenging the dominant design of educational systems. *Journal of e-Learning and Knowledge Society*, 3(2), 27-38.
- Wilson, S., Sharples, P., & Griffiths, D. (2008, September). *Distributing education services to personal and institutional systems using Widgets*. Paper presented at the First International Workshop on Mashup Personal Learning Environments (MUPPLE08). In conjunction with the 3rd European Conference on Technology Enhanced Learning (EC-TEL'08), Maastricht, The Netherlands.
- Wilson, S., Sharples, P., Griffiths, D., & Popat, K. (2011). Augmenting the VLE using widget technologies. *International Journal of Technology Enhanced Learning*, 3(1), 4-20.
- Wong, L.-H., & Looi, C.-K. (2011). What Seams Do We Remove in Mobile-assisted Seamless Learning? A Critical Review of the Literature. *Computers & Education*, 57(4), 2364-2381.
- Woolf, B. P. (2010, February 2014). A Roadmap for Education Technology. *Report of results on NSF sponsored workshops*. Retrieved April 2015, from <http://www.cra.org/ccc/files/docs/groe/GROE%20Roadmap%20for%20Education%20Technology%20Final%20Report.pdf>
- Wu, H.-K., Lee, S. W.-Y., Chang, H.-Y., & Liang, J.-C. (2013). Current status, opportunities and challenges of augmented reality in education. *Computers & Education*, 62, 41-49.
- Zhang, B., Looi, C.-K., Seow, P., Chia, G., Wong, L.-H., Chen, W., et al. (2010). Deconstructing and reconstructing: Transforming primary science learning via a mobilized curriculum. *Computers & Education*, 55(4), 1504-1523.

Chapter 5

Bricolaging learning buckets for orchestrating learning across spaces

This chapter describes part of the second cycle of the research process (see Figure 5.1). It is focused on the evaluation of the orchestration support provided by the learning buckets used in a *bricolage* (or *bricoleur*) mode. Chapter 4 described how the Bucket-Server (the system implementing the learning bucket notion) can be integrated with orchestration systems (such as GLUEPS-AR), in order to enhance the flexibility offered to the students by such approaches (thus helping enhance their orchestration support). Chapter 4 also explained that alternatively, the Bucket-Server can be integrated with technologies focused on web and physical spaces, such as Virtual Learning Environments (VLEs) and Augmented Reality (AR) apps. This chapter evaluates the orchestration support provided by the Bucket-Server (and therefore, by the learning buckets) in the latter type of integration (as an independent orchestration tool). The evaluation (Figure 5.2 marks it in the general diagram of the thesis) relied on a study, in which two teachers (the same as in the evaluation described in Chapter 3) used learning buckets integrated into Moodle. Thus, they created their learning designs directly in Moodle in a continuous refinement approach (also known as *bricolage* or *bricoleur* design approach). The teachers included learning buckets in several learning situations they performed during five months with a class of 64 students. Since the Bucket-Server was also integrated with multiple existing artifact providers (e.g., Web 2.0 tools such as Google Docs) and mobile AR clients (e.g., Junaio¹), many artifacts of multiple types were accessed from Moodle and from augmented physical spaces during the evaluation. This way, the learning buckets enabled not only to introduce a controlled degree of freedom in what the students were able to conduct during the enactment with learning tools and artifacts, but also to create across-spaces learning situations from Moodle. Since the teachers involved in the evaluation were the same teachers than the ones of Chapter 3, during the evaluation we also retrieved data regarding their opinions about the independent usage of both approaches: GLUEPS-AR, and the Bucket-Server. Appendix C includes a general template of the questionnaire used in the study. The content of this chapter is presented as a paper, prepared for its future submission to an international journal.

¹<http://www.junaio.com>. Last Access April 2015

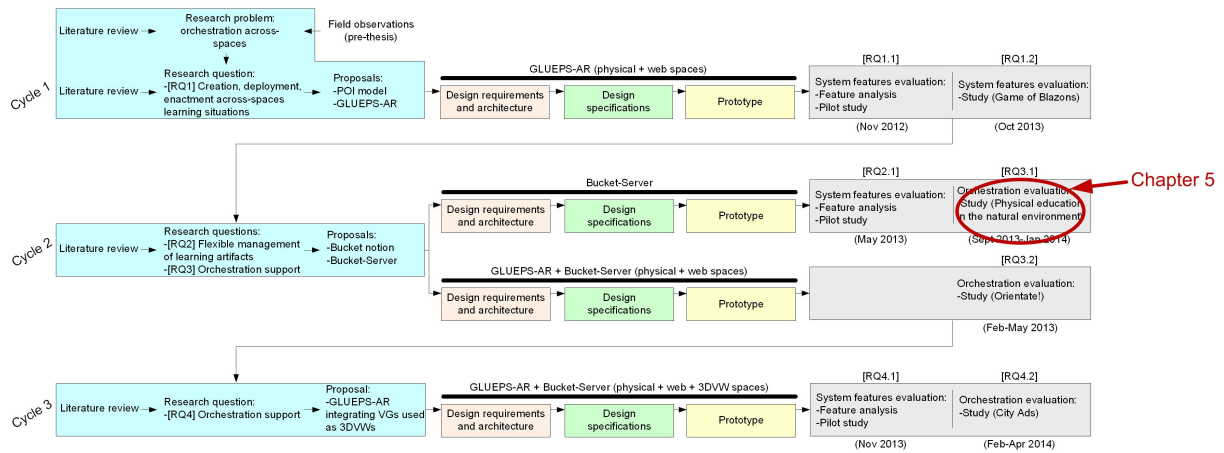

Figure 5.1: Part of the research process covered by Chapter 5.

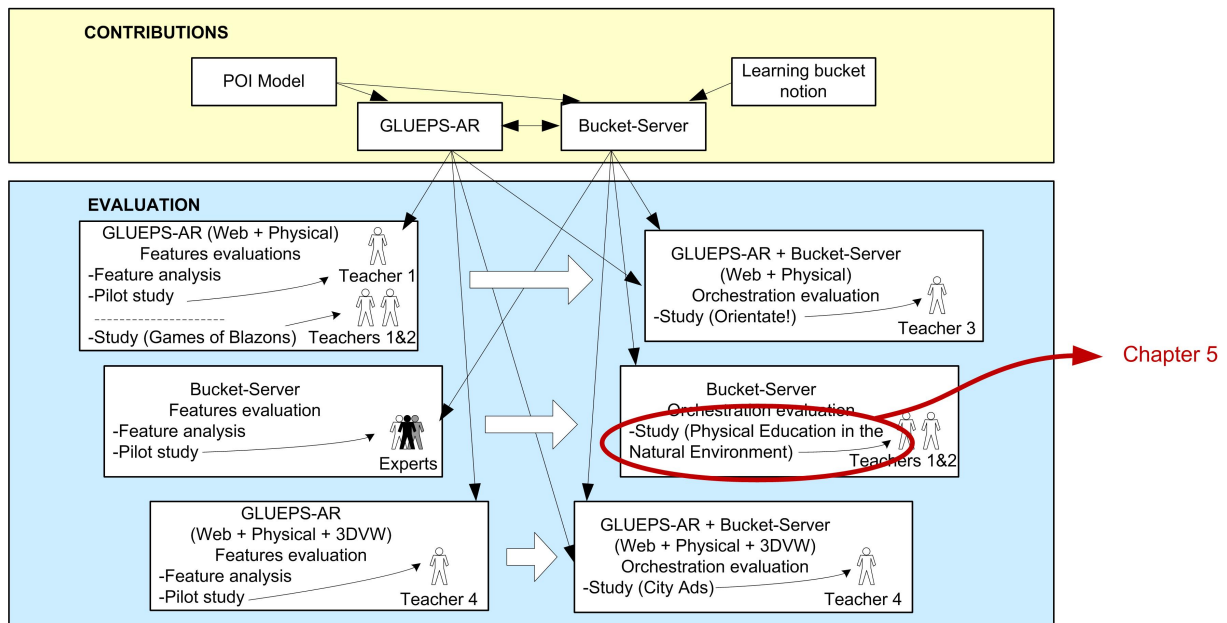

Figure 5.2: Evaluation works covered by Chapter 5.

To be submitted

Bricolaging learning buckets for orchestrating learning across spaces

Abstract: Teachers usually implement their pedagogical ideas in Virtual Learning Environments (VLEs) in a continuous refinement also known as *bricolage* approach. Recently, different proposals have enabled the ubiquitous access to VLEs by means of mobile devices, extending such *bricolage* mode to learning situations involving activities in VLEs and physical spaces. However, such proposals tend to present certain limitations for teachers to orchestrate learning situations conducted across different physical and virtual spaces: the teacher-controlled flexibility of the students to manage learning artifacts during the enactment; the integrated use of technologies commonly employed by teachers; and the seamless combination of the different spaces involved. Aimed to overcome these limitations, a learning bucket is a configurable container of learning artifacts of multiple types that are generated/accessed by the students across spaces, and that can be integrated with multiple technologies already used in education, such as VLEs, Web 2.0 tools and augmented reality apps. This paper presents an evaluation study that involved the across-spaces use of Moodle in *bricolage* mode and learning buckets during several learning situations. The results showed that the learning buckets overcame the aforementioned limitations, as well as suggested lines of future improvement, such as in the awareness of outdoor activities.

1 Introduction

During the last decades, technology has become usual in classrooms, generating complex ecologies of technological and social resources (Luckin, 2008). Moreover, the advances of mobile devices over the last years (e.g., in tablets and smart phones) is connecting the different physical and virtual spaces where learning can take place, such as classrooms, Virtual Learning Environments (VLEs, Keller, 2005), websites, homes, museums, the street, parks, forests, etc. (Delgado Kloos, Hernández-Leo, & Asensio-Pérez, 2012; Sharples, Sanchez, Milrad, & Vavoula, 2009). Augmented Reality (AR), a technology that enables the combination of physical and virtual objects in a physical environment (Azuma et al., 2001), can help make seamless such connections between physical and virtual spaces (Billinghurst & Duenser, 2012; Muñoz-Cristóbal et al., 2014). Thus, for instance, virtual learning artifacts created in a specific space (e.g., using a VLE in the classroom) can be accessed from other physical spaces (e.g., using AR in a park). The potential benefits for learning of these ubiquitous learning environments (Dyson, Litchfield, Lawrence, Raban, & Leijdekkers, 2009; Li, Zheng, Ogata, & Yano, 2004) fade due to the difficulties that teachers face for coordinating the learning situations conducted in such environments.

The coordination of authentic learning situations carried out in technology enabled educational settings has been a topic of interest during the last years in the Technology Enhanced Learning (TEL) research community (Balacheff et al., 2009; Dillenbourg, Järvelä, & Fischer, 2009; Roschelle, Dimitriadis, & Hoppe, 2013). Thus, using the *orchestration* metaphor,

multiple authors focused on a number of difficulties that teachers deal with to carry out the learning situations (see e.g., Dillenbourg & Jermann, 2010; Gutiérrez Rojas, Crespo García, & Delgado Kloos, 2012; Hernández-Leo et al., 2012; Niramitranon, Sharples, Greenhalgh, & Lin, 2010; Sharples & Anastopoulou, 2012; Slotta, Tissenbaum, & Lui, 2013). Some of these difficulties are the design of the learning situations, the regulation of the flexibility offered to the students, the pragmatic constraints of the teachers, or the alignment of the different resources in order to achieve the learning goals (Prieto, Dlab, Gutiérrez, Abdulwahed, & Balid, 2011).

Several authors have proposed systems that can help teachers orchestrate learning situations that may involve multiple physical and virtual spaces (see e.g., Delgado Kloos, et al., 2012). Since one of the first problems that teachers face to carry out such kind of situations is the creation of the situation itself, several proposals enable teachers to create such situations by means of authoring tools different from the technological setting in which the learning situation will be enacted (see e.g., Kaddouci, Peter, Vantroys, & Laporte, 2010; Klopfer et al., 2011; Muñoz-Cristóbal, et al., 2014; Niramitranon, et al., 2010; Ternier, Klemke, Kalz, van Ulzen, & Specht, 2012). However, the inclusion of authoring tools adds a new technological element in the already complex ecology of resources of classrooms (Alharbi, Athauda, & Chiong, 2014). There is a tension between the functionality and the complexity of authoring tools (Neumann et al., 2010). Depending on the educational context, the teacher pedagogical approach, and the intended goal, the benefits of supplementary authoring tools can or cannot be worth their additional complexity. Thus, for instance, they can be valuable for teachers interested in reusing and sharing their designs (Britain, 2004) or in creating complex collaborative learning situations (Hernández-Leo et al., 2006). On the other hand, authoring tools could not be worth for teachers who use a VLE to accompany their face-to-face class, building their courses week by week, and redesigning the plan continuously (Berggren et al., 2005).

An alternative to provide teachers with new authoring tools is enabling them to implement their pedagogical ideas (i.e., create learning situations, their activities and resources) directly in the technological settings that they use in their everyday practice, as is the case of the VLEs (e.g., Moodle¹; Dougiamas & Taylor, 2003). This alternative is also known as the *bricolage* (or *bricoleur*) approach (Berggren, et al., 2005). VLEs have been used during years following the *bricolage* approach in face-to-face and blended learning (Keller, 2005). However, they have been traditionally isolated from mobile devices (Casany et al., 2012), preventing their use in ubiquitous learning environments that include other physical spaces beyond the ones of blended learning (typically the classroom and home). Several approaches have proposed solutions to allow the ubiquitous access to VLEs by means of mobile devices (see e.g., Casany, et al., 2012; Glahn & Specht, 2010; Martin et al., 2009; Santamarina, Moreno-Ger, Torrente, & Manjón, 2010; Trifonova & Ronchetti, 2004). Nevertheless, these works tend to present limitations that may affect negatively certain orchestration aspects: most approaches have a limited, if any, capability to regulate the degree of flexibility offered to the students, which may be necessary in some pedagogies (Hannafin & Land, 1997; Zimmerman, 1990), especially in ubiquitous learning environments, which may demand a sharing of the orchestration load

¹ <https://moodle.org>. Last access April 2015.

with the students (Sharples, 2013); usually, the proposals do not allow the integrated use of technologies commonly employed by teachers (e.g., common VLEs or Web 2.0 tools), which may hamper their embedding in teachers' current practice (Cuendet, Bonnard, Do-Lenh, & Dillenbourg, 2013; Prieto, Wen, Caballero, & Dillenbourg, 2014); also, several proposals do not implement mechanisms to be aware of the context in which learning takes place, which may be an important factor in the seamless combination of different learning spaces (Li, et al., 2004; Milrad et al., 2013).

An alternative approach that can help overcome these limitations is the use of learning buckets in VLEs. A *learning bucket* (Muñoz-Cristóbal et al., 2013) is a configurable container of learning artifacts (e.g., web pages, widgets, instances of Web 2.0 tools) that are generated/accessed across different physical and virtual spaces. Teachers can configure a learning bucket with *constraints*, defining what is possible to do within it (e.g., which tools can be used). The learning bucket notion has been implemented in the Bucket-Server, a system that integrates learning buckets into multiple technologies (e.g., VLEs and mobile AR clients).

The research question that we tackle in this paper is *how the learning buckets help teachers orchestrate their learning situations conducted across different physical and virtual spaces*. In order to explore such question we have conducted an evaluation study in which two teachers used the Bucket-Server integrated with Moodle to carry out multiple learning situations of a course on Physical Education in the Natural Environment for pre-service teachers. The evaluation of the orchestration support provided by the learning buckets is the main contribution of this paper.

The rest of the document is structured as follows. The next section summarizes different approaches in literature that may help teachers orchestrate learning situations across spaces using VLEs in *bricolage* mode. Section 3 describes the learning bucket notion and the Bucket-Server system. Section 4 details the evaluation carried out, and finally, the main conclusions are summarized in Section 5.

2 Related work and limitations

2.1 Approaches using VLEs in *bricolage* mode and enabling ubiquitous access to VLEs

Several research works have explored during the last years how to allow access to the VLE resources from mobile devices (Casany, et al., 2012; Glahn & Specht, 2010; Zhang et al., 2010). Also, a number of authors have proposed web learning environments centered on inquiry based learning (IBL), which enable the creation and enactment of inquiries where mobile devices are used to collect different data. A system of this type is WISE (Linn, Clark, & Slotta, 2003), in which an inquiry project may include collecting activities conducted with PDAs and probes. Also Zydeco (Cahill, Kuhn, Schmoll, Pompe, & Quintana, 2010) is a web environment in which students can collect, with mobile devices, data of specific types: pictures, text, images, audio and video. nQuire (Mulholland et al., 2012) is another learning environment, which enables a flexible creation and enactment of inquiries which are configurable by the students. During the inquiry, the students can collect data of different types, to be analyzed afterwards

in the web environment. Recently, a mobile app integrated with nQuire has been created that can gather data from the multiple sensors of a mobile device (Herodotou, Villasclaras-Fernández, & Sharples, 2014). weSpot (Mikroyannidis et al., 2013) is an inquiry based web learning environment which includes the capabilities for the students of personalizing it and integrates external tools such as widgets and Web 2.0 tools. The system enables the collection of data (picture, video, audio, text and numeric) by means of a mobile app.

Other authors, instead of creating new web learning environments, propose the combination of existing VLEs and activities in other physical and virtual spaces. Colazzo, Ronchetti, Trifonova, & Molinari (2003) and Trifonova & Ronchetti (2004) propose a general architecture for integrating VLEs and mobile devices of multiple types, considering the capability of detecting the context of the mobile devices (e.g., with the information of their sensors, such as the location). A similar approach is the one of Glahn & Specht (2010): a theoretical system's architecture aimed to extend Moodle to different types of devices. The architecture includes some context-awareness capabilities: tracking the location of users, and enabling the access to specific Moodle resources from pre-defined "contexts" (physical regions delimited with geographical coordinates, and globally configured in Moodle). M2Learn is a framework to create mobile context-aware applications (e.g., able to detect the location using multiple sensors, such as GPS or RFID reader) and integrate them with VLEs, such as Moodle (Martin, et al., 2009). Santamarina et al. (2010) propose a general model to integrate portable game devices (mobile phones, PDAs, portable game consoles, etc.) with existing VLEs such as Moodle. Their approach enables the integration of mobile games as any other activity in a course within the VLE. Another approach is the one of Milrad and colleagues (Milrad, Kohen-Vacs, Vogel, Ronen, & Kurti, 2011). It consists in the integration of CeLS (a VLE and authoring tool) and MoCoLeS (a system to enable the enactment of collaboration scripts using mobile devices). Designs created with CeLS may include activities carried out in CeLS with computers and activities conducted outdoor using mobile devices. The same research group explores the use of contextualized learning objects, by means of a mobile app (LnuGuide) connected with Moodle (Sotsenko, Jansen, & Milrad, 2014). Another interesting approach is the architecture proposed by Conde and colleagues (Conde, García-Peñalvo, Alíer, Mayol, & Fernández-Llamas, 2014) for integrating Personal Learning Environments (PLEs) with VLEs, enabling also the access to different activities and tools from mobile devices. A slightly different approach is the last work carried out by Hernández-Leo et al. (2012) integrating their Signal Orchestration System (SOS) with Moodle (León Font, 2014). The SOS system enables the generation of signals (e.g., lights) from devices that can be worn by the students or be attached to specific resources or locations of the physical space. The signals indicate orchestration aspects of the collaborative learning flow (such as information related to group formation). Finally, Looi & Toh (2014) explored the orchestration implications of using, in a primary school during an academic year (Zhang, et al., 2010), a mobile learning environment (GoKnow MLE) composed of a mobile application and a website. The activities took place mainly in the classroom, with some of them conducted also at the students' homes.

2.2 Limitations of the reviewed approaches for the orchestration of learning situations conducted across physical and virtual spaces

All the approaches described help teachers orchestrate learning situations that involve the use of a VLE in *bricolage* mode and activities in physical spaces. Since there are several conceptualizations of the orchestration metaphor, Prieto, Dlab, Gutiérrez, Abdulwahed, & Balid (2011) proposed the *5+3 aspects* orchestration framework, which tries to encompass the multiple aspects that the different authors associate with orchestration. Table 1 summarizes such aspects. We have used this framework in order to characterize orchestration during the research work presented in this document.

Table 1. Different aspects in which the *5+3 aspects* framework (Prieto, et al., 2011) characterizes orchestration

Orchestration aspect	Description
Design	This aspect is related to the planning of the learning activities and the tools used to enact them. This aspect includes the conceptualization of learning designs, but also their implementation (setting up in the technological environment)
Management	This aspect deals with the regulation of the learning activities, and involves issues related to the management of the class, time, tools, artifacts and groups
Adaptation	This aspect is related to the capability of changing the design to both the local context of the classroom and the emergent events during the enactment of the learning activities
Awareness	This aspect deals with being aware of what happens in a learning situation
Roles of the teachers and other actors	This aspect refers to the role that the different actors (teachers and students) take in the orchestration
Pragmatism	This aspect deals with making TEL research results available to average (as opposed to TEL-expert) teachers, fitting with the constraints of the authentic settings of their everyday teaching practice
Alignment	This aspect is related to the coordination of the elements to be orchestrated (learning activities at various social levels, spaces, tools and scaffoldings used) in order to attain the learning goals
Theories	This aspect has to do with the theories and models used to orchestrate learning

Despite the aid provided by the reviewed approaches to the orchestration, they have typically a limited support in certain orchestration aspects, which are important in learning scenarios that involve activities in different physical and virtual spaces. In the following paragraphs we identify these limitations.

Role of the teachers and other actors. Traditionally, the orchestration load has been mostly tackled by teachers, but in some occasions, it could be worth sharing it with the students. That can be the case of student-centered and self-regulated learning approaches, in which students take an active role, and teachers provide them with autonomy to be responsible of their own learning process (Hannafin & Land, 1997; Zimmerman, 1990). Also, such sharing of the orchestration load can be interesting in some ubiquitous scenarios, where the activities are conducted in multiple physical and virtual spaces in which the orchestration can be very complicated for a teacher (Muñoz-Cristóbal, et al., 2013; Sharples, 2013). A way of sharing the orchestration load with the students is giving them flexibility in what they are able to do during the enactment, instead of predefining what they have to do. However, it is important to maintain a certain degree of guidance and structuring in the learning process, providing the required scaffolding for carrying out the learning activities that comply with the pedagogical intentions of the teacher (Dillenbourg & Tchounikine, 2007; Peter, Villasclaras-Fernández, &

Dimitriadis, 2013; Weinberger, Kollar, Dimitriadis, Mäkitalo-Siegl, & Fischer, 2009). Therefore, a controlled flexibility for students would be desirable in orchestration solutions (Dillenbourg, et al., 2009). Most of the aforementioned approaches have a scarce flexibility in what the students are able to do during the enactment. Thus, they are mostly restricted to the features of the VLE (in which most of the resources to use are predefined by the teacher), and the collection of artifacts of a limited set of types (basically pictures, audio, video or text). In addition, when flexibility is offered to students (as is the case of the PLEs, some VLE features such as the file uploading, or the capability of some IBL systems of collecting artifacts from mobile devices), the means provided to the teacher for controlling such flexibility are scant. Three exceptions are weSpot, WISE and nQuire. weSpot enables teachers to choose a set of phases and activities in the inquiry process from a list of suggested possibilities. In WISE, the teacher configures “steps”, including tools that can be used by the students, configuring also the permissions of the students over the tool. nQuire enables the students to create “measurements”, thus deciding what artifacts to collect.

Pragmatism. A way of adjusting to the teachers’ everyday practice is enabling them to use the tools that are regularly part of their practice (e.g., due to pedagogical or institutional decisions) (Cuendet, et al., 2013; Prieto, Wen, et al., 2014). In order to achieve it, the systems proposed for helping teachers orchestrate learning situations could enable them to employ existing technologies focused on different spaces which may have being already used by the teachers, such as existing VLEs (Keller, 2005), Web 2.0 tools (Conole & Alevizou, 2010), or AR apps (Wu, Lee, Chang, & Liang, 2013). However, several of the approaches described above are new learning environments (i.e., new VLEs) proposed by the researchers, thus, forcing teachers to learn how to use such (usually non-trivial) systems, which may also diverge from the institutional VLEs. In addition, several of the aforementioned learning environments are focused on specific pedagogies (e.g., inquiry-based learning), forcing teachers that want to include other methodologies in their practice to use multiple systems (Niramitranon, et al., 2010). Also, most of the described approaches provide students with a quite restricted set of tools to use, usually internal to the VLE, not enabling them to employ other tools commonly used in education, such as those of the Web 2.0 (Casany, et al., 2012). Only the architecture proposed by Conde and colleagues and weSpot enable the use of Web 2.0 tools (although weSpot is a new proposed VLE). Finally, all the approaches introduce typically new mobile clients to be used in physical spaces, instead of employing existing technologies (e.g., popular AR apps; Grubert, Langlotz, & Grasset, 2011) that the teachers could choose to use.

Alignment. In learning situations conducted across the different physical and virtual spaces that shape an ubiquitous learning environment, an important factor in the alignment is the connection of the different spaces to enable a seamless learning between them (Chan et al., 2006; Wong & Looi, 2011). A relevant element to provide this seamless combination of the different spaces is to be aware of the context where the learning takes place (Li, et al., 2004; Milrad, et al., 2013), which in addition, allows situated and contextualized learning (Kurti, Spikol, & Milrad, 2008). However, although several of the described approaches enable the access to web resources from mobile devices anywhere, most of the approaches do not include context-awareness features, and therefore, such resources are not related to the context of the student in which the access occurs and learning takes place. This lack would prevent, e.g., from linking different learning resources providing information about a type of

tree, a monument, or a painting, to the corresponding physical object of interest (tree, monument or painting). In addition, the IBL proposals connect the spaces in one way: from the field to the VLE (collecting artifacts). But they do not connect the resources created in the web environments with objects or locations in the field, which may hamper the possible contextualized learning and the seamless connection of the spaces. On the other hand, some of the mentioned approaches do include some context-aware features, thus being aware of characteristics of the students' context such as the location, the activity or the user (Kurti, et al., 2008). Such approaches are weSpot (with theoretical context-aware features indicated in the corresponding publications, but not yet implemented as far as we know); nQuire, by means of its new mobile app enabling the use of the mobile sensors; the architectures proposed by Trifonova and colleagues and by Glahn & Specht (the latter, as far as we know, not implemented); the systems proposed by Milrad and colleagues; and M2Learn.

As shown, all the reviewed approaches enable the use of VLEs in *bricolage* mode, and help teachers orchestrate learning situations that may involve different physical and virtual spaces. Thus, several of them provide solutions that help in some of the three identified limitations for the teacher orchestration of learning situations conducted across physical and virtual spaces. However, as far as we know, none of the approaches has proposed solutions for overcoming all three limitations (see Table 2). Therefore, there is a need of alternative proposals aimed to help teachers orchestrate their across spaces learning situations, emphasizing such three orchestration aspects affected by the limitations (roles of the teachers and other actors, pragmatism, alignment). In the following section we describe the learning buckets, an approach that can help in this line.

Table 2. Support provided by the different approaches to the identified limitations in orchestration aspects (Y=Supports the limitation; N=Does not support the limitation; L=Provides a limited/partial support; T=Supports theoretically the limitation, but as far as we know it is not yet implemented)

Limitations	(Cahill, et al., 2010)	(Casany, et al., 2012)	(Conde, et al., 2014)	(Glahn & Specht, 2010)	(León Font, 2014)	(Linn, et al., 2003)	(Martin, et al., 2009)	(Mikroyannidis, et al., 2013)	(Milrad, et al., 2011)	(Mulholland, et al., 2012)	(Santamarina, et al., 2010)	(Sotsenko, et al., 2014)	(Trifonova & Ronchetti, 2004)	(Zhang, et al., 2010)
<i>Roles of the teachers and other actors:</i> Teacher-controlled flexibility of the students to manage learning artifacts during the enactment	L	N	L	N	N	Y	N	Y	N	Y	N	N	N	Y
<i>Pragmatism:</i> Integrated use of technologies commonly used in current educational practice (e.g., common VLEs and Web 2.0 tools)	N	Y	Y	L	L	N	Y	L	N	N	L	L	Y	L
<i>Alignment:</i> Seamless combination, using context-awareness, of the different spaces involved	N	N	N	T	N	N	T	T	Y	L	N	Y	Y	N

3 Learning bucket notion and Bucket-Server system

A *learning bucket*² (Muñoz-Cristóbal, et al., 2013) is a conceptual proposal that can help teachers orchestrate learning situations that involve multiple physical and virtual spaces. A learning bucket is a configurable container of learning artifacts of multiple types (e.g., 3D models, web pages, artifacts of Web 2.0 tools such as Google Docs³ documents, etc.). A bucket can be embedded in multiple existing technologies focused on different spaces (e.g., VLEs in web spaces, AR apps in physical spaces, etc.) and its learning artifacts can be positioned in multiple physical and virtual spaces using several positioning types (e.g., geographical coordinates, markers, etc.). Teachers can include learning buckets in activities of a learning situation, and configure such buckets with *constraints* for restricting what students will be able to do within them during the enactment (e.g., tools to use, permissions, positioning types, etc.). In the case of VLEs used following a *bricolage* approach, the teachers can create buckets from their usual VLE, including them in activities of a VLE course, like any other resource. Afterwards during the enactment, teachers and students are able to use the bucket (under the constraints configured by the teacher) to create artifacts of multiple types. These artifacts can be positioned (e.g., automatically or manually by the students) in multiple physical and virtual spaces (e.g., the students could position them in a physical space using geographical coordinates). Since the learning bucket can be embedded in multiple software applications focused on different spaces, the artifacts created in a space (e.g., in a web space using a VLE) could be accessed afterwards from other spaces where the artifacts are positioned (e.g., from a physical space using an AR app), thus enabling across spaces learning situations. Figure 1 illustrates the learning bucket notion.

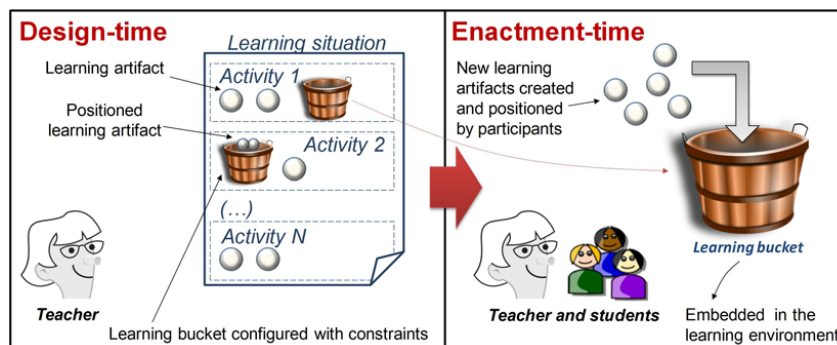

Figure 1. Learning bucket notion

By using buckets, the teachers can include flexibility in what the students are able to do with learning artifacts during the enactment. Thus, the learning buckets enable students, for instance, to take technological decisions (e.g., regarding the artifacts to use), contextual decisions (e.g., related to the location and time for creating and accessing artifacts), and arbitrary decisions (e.g., the number of artifacts to create). Such flexibility is included even when the teachers use a learning environment not providing natively such flexibility, in which all resources and tools to use are predefined (and sometimes created) by the teacher.

² The learning bucket notion is described in detail in Chapter 4 of the dissertation.

³ <http://www.google.com/docs/about/>. Last access April 2015.

Including such flexibility may help teachers share the orchestration load with the students, since part of the load is transferred to the students. The constraints configured in the bucket limit the flexibility, allowing the teachers to regulate the balance between guidance and freedom (Dillenbourg & Tchounikine, 2007).

The learning bucket notion has been implemented in the *Bucket-Server*⁴ system, which by means of an Application Programming Interface (API), enables its eventual integration with different applications (see Figure 2, top). With the API, the applications can create and manage buckets and their artifacts. As shown in Figure 2 (top), multiple artifacts providers could be integrated with the Bucket-Server, allowing thus the use of their artifacts within buckets.

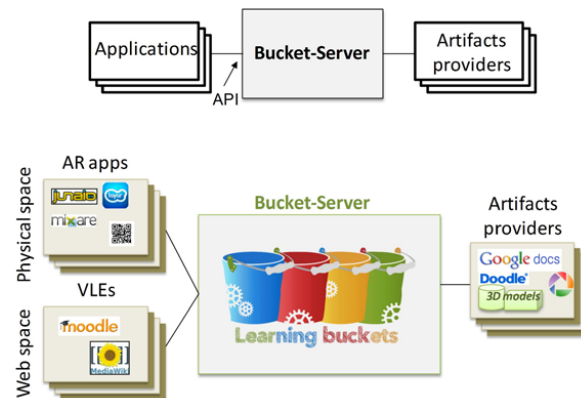

Figure 2. Schema of the integration of the Bucket-Server with applications and artifacts providers (top), and schema of the implemented prototype (bottom)

We have created a prototype of the Bucket-Server (see Figure 2, bottom) in order to explore its use in educational scenarios. In the prototype, we have integrated the Bucket-Server with existing VLEs (web space) and mobile AR apps (physical space). Specifically, the prototype integrates four AR apps (Junaio⁵, Layar⁶, Mixare⁷ and any common QR code reader) and two VLEs (Moodle, and Mediawiki⁸). In addition, the prototype is integrated with more than twenty existing artifacts providers, including several Web 2.0 tools (e.g., Google Docs, Google Slides⁹, Picasa¹⁰, etc.) and widgets (e.g., chat, forum, whiteboard, etc.). Figure 3 shows screenshots of learning buckets embedded in Moodle and Junaio, illustrating also some of the positioning types implemented in the prototype: geographical location and AR markers (the prototype allows also the positioning of artifacts in physical spaces with QR codes). The use of AR and these positioning types enable some context-awareness capabilities, such as awareness regarding time, position, device, activities performed, and user information. Such capabilities

⁴ The Bucket-Server system is described in detail in Chapter 4 of the dissertation.

⁵ <http://www.junaio.com>. Last access April 2015.

⁶ <https://www.layar.com>. Last access April 2015.

⁷ <http://www.mixare.org>. Last access April 2015.

⁸ <http://www.mediawiki.org>. Last access April 2015.

⁹ <http://www.google.com/slides/about/>. Last access April 2015.

¹⁰ <https://picasa.google.com>. Last access April 2015.

enable the creation of and access to contextualized learning artifacts, thus helping achieve a seamless connection between the different physical and virtual spaces.

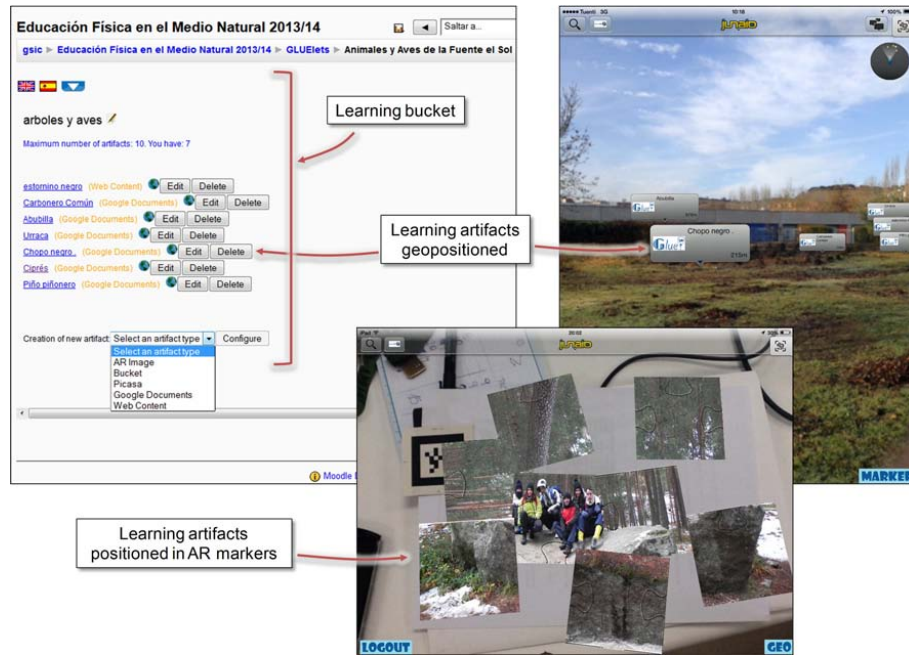

Figure 3. Screenshots of learning buckets embedded in Moodle (top-left) and Junaio (top-right and bottom)

Table 3 summarizes the different Bucket-Server features that may aid teachers in each of the facets in which the 5+3 aspects framework (Prieto, et al., 2011) categorizes orchestration. The Bucket-Server provides significant support in the three orchestration aspects (roles of the teachers and other actors, pragmatism and alignment) that were identified as the main limitations in existing approaches for the orchestration of learning situations conducted across different physical and virtual spaces (see Section 2). Therefore, it could be an alternative to such approaches for orchestrating ubiquitous scenarios. In the next section we evaluate the support provided by the Bucket-Server to the orchestration of several learning situations that involved multiple physical and virtual spaces as well as the use of a VLE in *bricolage* mode.

Table 3. Features of the Bucket-Server that may help in the different orchestration aspects of the 5+3 aspects framework (Prieto, et al., 2011)

Orchestration aspect	Feature
Design	Use of the <i>bricolage</i> approach for creating from within a VLE learning situations involving multiple physical and virtual spaces
Management	Embedding of buckets and artifacts in learning environments in different spaces, and automatic creation of artifacts of several types
Adaptation	Possible changes in buckets before, during and after the enactment time
Awareness	Integrated view of bucket and artifacts in the VLE, which acts as a control panel
Roles of the teachers and other actors	Enabling a flexible and teacher-controlled management of learning artifacts during the enactment, thus sharing of the orchestration load with the students

Pragmatism	Possible use of multiple existing tools (VLEs, mobile AR apps and artifact providers such as Web 2.0 tools) that may fit with different teachers and institutions constraints.
Alignment	Integration of the several systems and artifacts in different physical and virtual spaces and creation/access to contextualized learning artifacts from such spaces
Theories	Enabling a <i>bricolage</i> mode to coordinate the learning situations

4 Evaluation

This section describes the evaluation carried out to explore the research question that guides our work: *how do the learning buckets help teachers orchestrate their learning situations conducted across different physical and virtual spaces?*

Situation	Spaces	Tools	Description	Snapshots
1 Orienteeing (1h classroom 5h outdoor 1h online)	Classroom, web, gym, Valladolid park	Smartphones, QR code reader, Picasa, Google Forms, orienteeing map, Moodle	Two sessions and a final individual report. The first session consisted of a lecture and some orienteeing activities (without technology) in the gym and its surroundings. The second session was an orienteeing race in a big park of the city. The class was divided into 2 big groups. While a big group carried out the orienteeing race, the other one conducted an activity regarding the use of the compass. For the orienteeing race, the big group got into pairs. Using an orienteeing map, they had to find 8 markers. Three markers contained QR codes that they had to scan. In two of them they had to answer a questionnaire. In the remaining one they had to upload a picture and comment it.	
2 Hiking (2h classroom 6h outdoor 1h online)	Classroom, web, Palencia mountains	Smartphones, QR code reader, Junao, Picasa, websites, Moodle	Three sessions and a final individual report. The first session was a lecture about hiking. The second session consisted in a hiking route. The class was divided into 4 big groups, each one belonging to a different category: geographers, ethnologists, zoologists and botanists. Each big group was split into 3 groups of 5 students. Along the route, the groups had to gather evidences (pictures) of elements related to their category, and carry out several activities in multiple stops. In one of the activities, students used AR to access geopositioned information about elements of the area related to the categories. In other activity, each group had to take a picture, and another group had to replicate the picture (the pictures were uploaded to Picasa). The third session was a joint evaluation of the hiking route.	
3 School paths 1 (2h classroom 4,5h outdoor 1,5h CENEAM room 1h online)	Classroom, web, Segovia mountains, CENEAM room	Smartphones, tablets, QR code reader, Junao, Picasa, Google Forms, websites, Moodle	Three sessions and a final individual report. 6 students, together with the teachers, organized a hiking route, which was conducted by half of the class with 25 children (around 9-12 years old) of rural schools of the area accompanied by 4 teachers of the schools. The children were divided into 6 groups (one per organizer). During the route, as well as in an environmental education center (CENEAM) they carried out several activities, such as: using AR to see geopositioned information of elements in the environment; questionnaires accessed using QR codes; an AR puzzle using AR markers; locating the place where some given photos were taken, and replicate the photos, uploading them to Picasa. Before and after the route, there were two sessions to prepare and evaluate the hiking route.	
4 General session in campus (1h classroom 3,5h multiple locations)	Classroom, web, gym, campus surroundings	Smartphones, tablets, QR code reader, Junao, Picasa, Google Forms/Docs, websites, orienteeing map, Moodle	Two sessions. In a first one, three students created and positioned different learning artifacts to be used in the subsequent session. In a second session, 48 students, in groups of 6, had to carry out a gymkhana-type learning situation with several activities regarding multiple sports: conducting an orienteeing route with mountain bikes, in which the markers contained QR codes to answer a questionnaire and upload a picture; a climbing activity combined with an AR puzzle and a QR code linked to a questionnaire; an orienteeing activity in which some members of the group guided, using a walkie-talkie, other members to find the markers, which contained QR codes linked to questionnaires; an orienteeing activity conducted in wheelchair, in which the instructions were given with a QR code linked to a Google Docs.	
5 School paths 2 (2h classroom 5,25h outdoor 1h online)	Classroom, web, Valladolid park	Smartphones, tablets, Junao, QR code reader, Picasa, Google Forms/Docs, websites, Moodle	Three sessions and a final individual report. 10 students, together with the teachers, organized a hiking route, that was conducted by half of the class with 75 children (around 7 years old) and 3 teachers of a Valladolid's school. They carried out preliminary activities in the school's classrooms with the children. Then, they hiked in a nearby big park, wherein they carried out several activities. Finally, they came back to the school, finishing the learning situation with some activities in the classrooms. Some of the activities were conducted using mobile devices, such as accessing with AR (using geoposition and QR codes) artifacts of different types related to animals and plants of the area (images, questionnaires, Google Docs and websites). Before and after the route, there were two sessions to prepare and evaluate the hiking route.	

Figure 4. Learning situations carried out during the course on Physical Education in the Natural Environment

We have conducted the evaluation through a study with the two teachers of a course on Physical Education in the Natural Environment for pre-service teachers, corresponding to the last year (out of four) of the undergraduate university degree in Primary Education of the University of Valladolid (Spain). The two teachers were the main teacher of the course and an

assistant teacher. They used learning buckets in multiple learning situations during the five months of the aforementioned course (from September 2013 to January 2014) with a class of 64 students. Figure 4 describes the relevant parts, regarding the use of buckets, of such learning situations. The learning situations took place in different provinces of the *Castilla y León* Spanish region, such as mountains in Palencia and Segovia, two parks in Valladolid, classrooms, a gym, and the surroundings of the university campus. The aim of the situations was to help students develop skills and capabilities to be able to design, organize and conduct physical education activities of multiple types with children in the natural environment. The structure of the course, its main contents, the learning situations, sessions and field trips were not significantly altered with respect to the ones of the previous years. In the following sections we describe the evaluation method and the main results obtained.

4.1 Method

We have followed the Evaluand-oriented Responsive Evaluation Model (EREM) (Jorrín-Abellán & Stake, 2009) to design and carry out the evaluation. The EREM is a framework conceived to guide practitioners involved in the evaluation of a huge variety of innovations in collaborative ubiquitous learning environments. It is framed within the Responsive Evaluation approach (Stake, 2004), promoting responsiveness to key issues and problems recognized by participants at the site and stakeholders elsewhere (Jorrín-Abellán & Stake, 2009). The EREM is oriented to the activity, the uniqueness and the plurality of the phenomena to be evaluated (evaluand). This evaluation method follows an interpretive research perspective (Cohen, Manion, & Morrison, 2007; Orlikowski & Baroudi, 1991) that does not pursue statistically significant results or generalizations. Rather, it aims at a deeper understanding of the concrete phenomena under study (Guba, 1981), in our case, the orchestration support provided by the learning buckets to teachers conducting learning situations involving multiple physical and virtual spaces.

To explore the research question, we set up an evaluation team composed of researchers with different backgrounds (educational and technological) and expertise (including novel, experienced and expert evaluators). We carried out an anticipatory data reduction process (Miles & Huberman, 1994) during the evaluation design (see Figure 5). Since the aim of the evaluation is to explore the orchestration support, we used the *5+3 aspects* orchestration framework (Prieto, et al., 2011) as a basis for the anticipatory data reduction process. Although the learning buckets emphasize some of the orchestration aspects (roles of the teachers and other actors, pragmatism, alignment), we have evaluated the orchestration support provided by the learning buckets in all aspects of the framework. This has as main purposes to understand the holistic support to orchestration provided by the learning buckets, and to identify possible weaknesses in any of the other orchestration aspects. Such weaknesses could pass unnoticed in an evaluation of a subset of the aspects. In the anticipatory data reduction process, we defined an issue as the main conceptual organizer of the evaluation process: *how does the Bucket-Server help the participant teachers orchestrate their learning situations conducted across different physical and virtual spaces?* Thus, we explored the orchestration support provided by the learning buckets by means of studying the use in authentic settings of the system implementing them: The Bucket-Server. We divided such issue, centered in orchestration, into eight more concrete topics to help us understand the different dimensions within the issue. These topics correspond to the eight facets by which the *5+3 aspects*

framework characterizes orchestration¹¹: design, management, adaptation, awareness, roles of the teachers and other actors, pragmatism, alignment and theories (see Table 1). In the same way, each topic was explored by means of various informative questions. The schema *research question-issue-topics-informative questions* (see Figure 5) guided also the data collection during the evaluation, which was carried out using a profuse set of data gathering techniques (see Table 4). During the data analysis, a single member of the evaluation team coded the data sources using the aforementioned anticipatory data reduction schema as an initial category tree thus predetermining the initial set of codes to use a-priori (Miles & Huberman, 1994). Finally, the evaluation team interpreted the data and identified the findings.

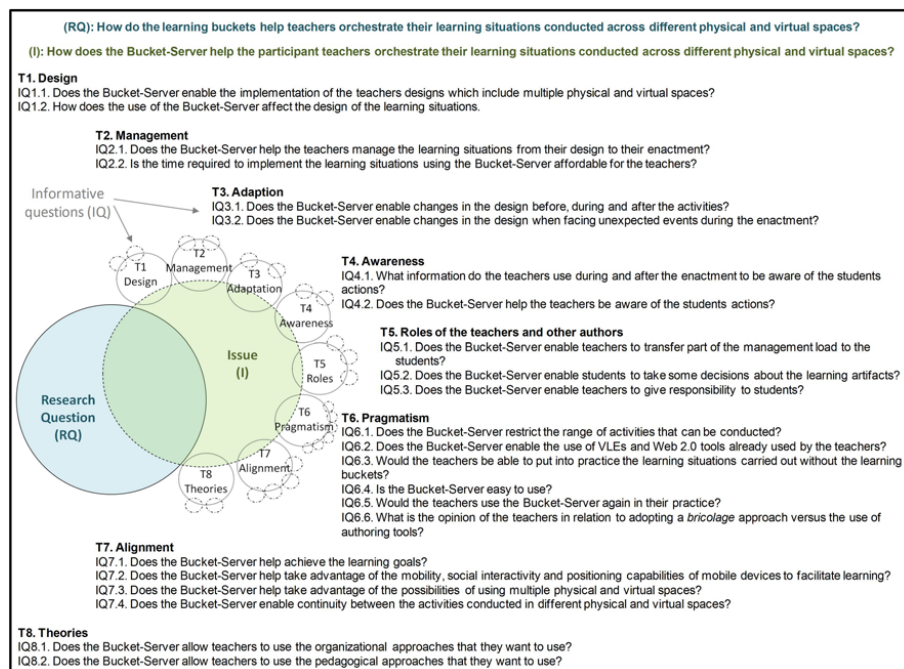

Figure 5. Anticipatory data reduction schema showing research question (RQ), issue (I), topics (T) and informative questions (IQ)

Attending to the usual criteria of the interpretive perspective to ensure the quality of a research process, we have used different strategies to increase the credibility, transferability, dependability and confirmability of our research (Cohen, et al., 2007; Guba, 1981; Miles & Huberman, 1994; Shenton, 2004): prolonged engagement during five months of work with the teachers and persistent observation in the field; member checking, obtaining feedback from the informants about the data and the interpretations; acknowledgement of teachers opinions, by interviewing them and having multiple meetings; integration of the thorough

¹¹ A similar evaluation approach, using the 5+3 framework as an evaluation instrument following the EREM model and conducting an anticipatory data reduction process, was followed by Prieto, Asensio-Pérez, et al. (2014), although in that case restricted to 3 orchestration aspects. Also Looi & Toh (2014) used the 5+3 orchestration framework as a research instrument to explore the orchestration support in a technological scenario (in that case with a different methodological approach).

collaborative observation reports in a single portfolio, thus enabling a thick description of the phenomenon under scrutiny, reported in detail to the whole evaluation team; peer review within the evaluation team to avoid bias; triangulation of data sources, methods and researchers to crosscheck data and interpretations. The triangulation of researchers was conducted by involving in the evaluation team experienced researchers with distinct perspectives (i.e., with pedagogical or technological background). Such researchers participated conducting independent observations, which were compiled and discussed in a joint collaborative multimedia report for each session. The triangulation of methods involved the use of several data gathering techniques (questionnaire, interview, etc.). The triangulation of data sources was carried out employing multiple data sources and informants, ensuring that each finding was corroborated by multiple pieces of evidence of different types. We have adopted a descriptive style to report the research and its results, with a detailed account of the context, participants and learning situation, as well as of the evaluation design and its implementation, including the data gathering techniques employed. Such detailed account is another strategy typically employed in qualitative research to achieve credibility and transferability of the results.

Table 4. Data gathering techniques

Technique	Description
Collection of participant-generated artifacts (Art)	Collection of a diverse set of electronic artifacts generated by the teachers and the students (emails with teachers, learning designs and products, evaluation report of teachers of a school). Used to register the processes of design, implementation (setting up of the technological environment) and enactment as well as the use of the different systems.
Screen recording (Screen)	Recording of the actions conducted in the computer by the teachers as well as video and audio recording of their actions out of the computer, during some implementation sessions. Used to understand the design and implementation processes.
Observation (Obs)	Naturalistic, semi-structured observations during initiation session, implementation sessions and enactment of sessions involving learning buckets. The observations were guided by an anticipatory data reduction schema (see Figure 5), and conducted by up to six different observers. The data collected were chat messages, audio/video, pictures and observation notes. Used to register the actions, impressions and other emergent issues of the teachers and students.
Questionnaire (Quest)	Web-based exploratory questionnaire. It was composed of open-ended and closed items (6-point scale [1=strongly disagree, 2=disagree, 3=somewhat disagree, 4=somewhat agree, 5=agree, 6=strongly agree] + don't know/no answer). Used to get the initial opinions of the teachers over a wide range of matters before conducting the interview.
Interview (Int)	Qualitative, semi-structured, face-to-face, one-to-one conversation with the teachers (recorded and transcribed). Used to capture the opinions of the teachers in depth, after an initial analysis of other data sources (e.g., observation data, questionnaire answers, etc).

Figure 6 shows the evaluation process, which has been divided into happenings (evaluation events), including the different data gathering techniques employed, along with the labels used to refer to them throughout the text. During the first happening (H1 in Figure 6) in September 2013, the teachers started to design the learning situations of the course, basing on the activities carried out the previous years, and including the use of mobile devices to connect the physical locations with Moodle and other web resources. A member of the research team helped the teachers in their doubts regarding the technological alternatives and affordability

for implementing their ideas. Also, the researcher explained them how to create learning buckets from Moodle in a 1,5 hours session, in which the teachers finally created different buckets and artifacts within them. Afterwards, from October 2013 to January 2014, the teachers carried out several learning situations using learning buckets (see Figure 4). The integration of the Bucket-Server prototype with the institutional Moodle of the university would have required a long logistical process, which would have prevented from using buckets in the course 2013/2014. Therefore, jointly, teachers and researchers decided to use the institutional Moodle in parallel with another Moodle installation integrated with the Bucket-Server. Thus, activities using buckets were conducted in the secondary Moodle and links in the institutional Moodle connected to them. The second happening (H2) involved the implementation (setting up of the technological environment) and enactment of an orienteering race in a park. For the implementation, according to the instructions of the main teacher, the assistant teacher created remotely the activities, a learning bucket and other resources needed (see Table 6), with the (chat) support of a member of the evaluation team. The assistant teacher implemented also, with the help of an evaluator, the learning buckets agreed with the main teacher (see Table 6) for a hiking route that was conducted in Palencia mountains (160 Km far from Valladolid) (H3). The fourth happening (H4) consisted of the implementation and enactment of a hiking route in Segovia mountains (130 Km far from Valladolid). In this occasion the main teacher was in charge of creating learning buckets and artifacts (see Table 6), with the help of an evaluator, to support different activities to be carried out during the route. Afterwards, in December, the fifth happening (H5) comprised three sessions: A first session in which the main teacher, with the help of the assistant teacher and sporadic support of an evaluator, created in Moodle a learning situation, which included learning buckets (see Table 6), for a general review of the different topics studied; a second session in which a group of students created and positioned learning artifacts within the buckets (see Table 6); and the final session, with the enactment of the learning situation with the whole class. The last learning situation (H6) was performed in January 2014, when the main teacher created, on his owns and without support, the necessary buckets the night before the enactment. Finally, feedback from the teachers was gathered using a web-based questionnaire and interviewing them.

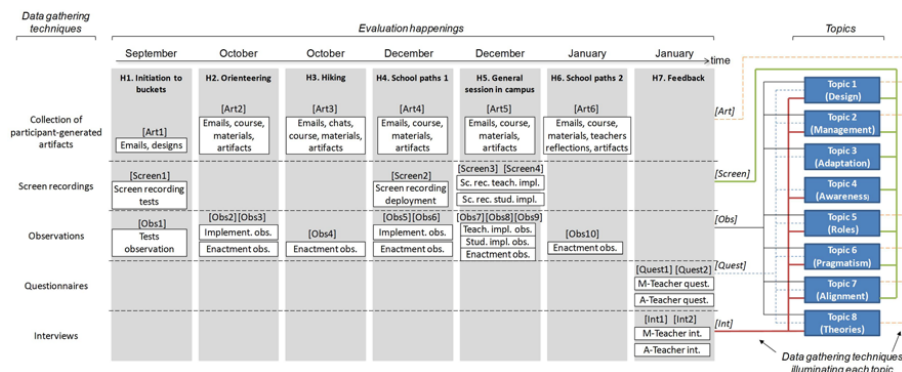

Figure 6. Evaluation happenings, topics, and data gathering techniques (see Table 4) used during the evaluation

4.2 Results

This section describes the main results obtained in the evaluation process, organized following the 5+3 aspects orchestration framework (see Table 1) used in the anticipatory data reduction process (see Figure 5). A summary of the main findings is compiled in Table 5. The table indicates also the data sources that support the findings (using the same labels as in Figure 6), and therefore, it exemplifies the triangulation process followed throughout this study. Due to space restrictions and for a better readability, only a selection of excerpts of these data sources is presented in Section 4.2.

Table 5. Main findings of the evaluation process

Orchestration aspect	Findings	Supporting data
Design	The Bucket-Server enabled the teachers to implement, using a VLE such as Moodle in a <i>bricolage</i> approach, learning designs involving multiple physical and virtual spaces	Quest1-2, Int1-2, Art2-6, Screen2-4, Obs1-2, Obs5, Obs7, Obs10
Management	The Bucket-Server helped manage, in an affordable time, the learning situations, by unifying in a single element of the VLE multiple learning artifacts generated with different tools and positioned in several spaces using a number of positioning types	Quest1-2, Int1-2, Art6, Screen1-4, Obs2, Obs7-10
Adaptation	The Bucket-Server enabled teachers to make runtime changes in the learning buckets and their artifacts, but this capability was only used in Moodle (web space), and not in activities involving physical spaces (e.g., during field trips)	Quest1, Screen2-4, Obs1, Obs3, Obs5, Obs8
Awareness	The Bucket-Server provided a unified runtime view of the artifacts created by the students, but the buckets were not used during the activities in physical spaces to monitor the students' actions, and were scarcely used after the activities to review the students' works	Quest1-2, Int1-2, Screen 3
Roles of the teachers and other actors	The Bucket-Server enabled teachers to transfer part of the orchestration load to the students, but it required a previous training of the students, which also increased the teachers' load	Quest1-2, Int1-2, Art5, Screen1, Screen3-4, Obs4, Obs6-9
Pragmatism	The Bucket-Server supported the constraints of non-ICT expert teachers in authentic learning situations of their everyday practice, which involved a VLE of the same type than the one of their institution, common Web 2.0 tools, and multiple physical spaces.	Quest1-2, Int1-2, Art1-4, Art6, Screen1-4, Obs2-9
Alignment	The Bucket-Server helped connect different physical and virtual spaces by enabling the creation of and access to positioned learning buckets and artifacts from the different spaces	Quest1-2, Int1-2, Art2-6, Screen2-3, Obs3-10
Theories	The Bucket-Server changed the teachers' previous way of organizing the learning situations, which they perceived as useful and expected. The pedagogical essence of the learning situations was not altered	Quest1-2, Int1-2, Art5, Obs7

4.2.1 Design

With respect to this aspect, the evaluation showed that **the Bucket-Server enabled the teachers to implement, using a VLE such as Moodle in a *bricolage* approach, learning designs involving multiple physical and virtual spaces**. The teachers implemented several designs which included learning artifacts of different types that were accessed from the web space of Moodle, and from multiple physical spaces using different positioning types, such as QR codes, AR markers and geographical coordinates (see, e.g., [Quest1-2]^A in Table 7). Table 6 indicates the different learning buckets and artifacts that were created by the teachers and the

students. The Bucket-Server allowed teachers to include in their settings technologies that they had not used previously in their classes (not only learning buckets, but also other technologies such as mobile devices or AR). As a result, they were not able to conceive initially learning activities taking advantage of the new possibilities that the technology offered, and they demanded help from the evaluation team, who proposed different activities and possible uses of the technology (see, e.g., [Int1] in Table 7). The teachers took special care in including only activities that they considered aligned with the objectives, without losing the essence of the learning situations (see, e.g., [Obs7] and [Int1-2] in Table 7). However, the need of external help decreased continuously throughout the course, being the teachers independent in the last learning situations (especially in the last one, see, e.g., [Art6] in Table 7). In addition, the use of the learning buckets and the rest of new technologies by the teachers (mobile devices, QR codes, AR, etc.) had an impact in the design of the method (how the students would reach the objectives), being the contents of the learning situations less affected (see, e.g., [Quest1-2]^B and [Int1-2] in Table 7). This alteration in the design was due to the new possibilities given by the learning buckets to enrich the learning situations, and was perceived as positive by the teachers (see, e.g., [Int1-2] in Table 7). Another interesting fact is related to the approach used by the teachers to carry out the design tasks. They adopted a model based on continuous refinement, so that some design decisions were taken right before the activity started. The Bucket-Server showed to provide a good support to this design approach. Table 7 shows some excerpts of evidence that illustrate the findings described.

Table 6. Learning buckets and artifacts created by the teachers and the students in the different learning situations [Art2, Art3, Art4, Art5, Art6, Screen3, Screen4]

Learning situation	Teachers	Students
1. Orienteering	(Assistant teacher) A bucket with three artifacts positioned in QR codes: 2 Google Form questionnaires, and a bucket (to upload pictures).	21 Picasa pictures
2. Hiking	(Assistant teacher) 14 buckets: a bucket with 12 web contents geopositioned, and a bucket including 12 bucket positioned in QR codes (to upload pictures).	8 Picasa pictures
3. School paths 1	(Main teacher) 10 buckets: a bucket containing 6 buckets positioned in QR codes (to upload pictures); a bucket containing 9 pieces of an image positioned in AR markers (an AR puzzle); a bucket with 4 Google Form questionnaires positioned in QR codes; a bucket with 6 web contents geopositioned.	10 Picasa pictures geopositioned
4. General session in campus	(Main teacher) 5 buckets: a bucket to enable students create questionnaires positioned in QR codes; a bucket including a questionnaire positioned in a QR code and another bucket positioned in a QR code (to upload pictures); a bucket including two questionnaires positioned in QR codes; a bucket with a questionnaire and a Google Docs, both positioned in QR codes.	4 questionnaires positioned in QR codes; the 9 pieces of an image positioned in AR markers to create an AR puzzle; 8 Picasa pictures
5. School paths 2	(Main teacher) 3 buckets: a bucket with a questionnaire positioned in a QR code; a bucket with a web content geopositioned and 6 Google Docs geopositioned; a bucket including three artifacts positioned in QR codes (Picasa, web content, Google Docs).	

Table 7. Selected excerpts of evidence related to the design orchestration aspect

Data source	Excerpts
[Quest1-2]	^A To the assertion "With the learning buckets I was able to implement learning designs that involved multiple physical and virtual spaces (web, VLE, classroom, playground, physical environment, etc.)" both, main and assistant teachers, answered 6, "Strongly agree". ^B To the assertion "I had to adapt my learning design to the technology that I used" both, the main teacher and the assistant teachers answered 4, "Somewhat agree".
[Int1]	To a question regarding how the systems affect the learning design, the main teacher answered "Well, I think that there is an inverse relation. (...) When I started to say "let's see what we can do here", I felt like "tell me what I have to do, or I will just take some standard activity and I'll do it". But when you can see how it works, you can select artifacts (...) In the beginning, when you said that I could choose among a number of artifacts, I just thought "well, by the moment I choose one". But later I chose another, you are being aware, you can reflect it, you can leave it to be chosen by others [the students] (...) Therefore, I think there is a previous training phase to be aware of its actual potential, and be able to be more autonomous, original and authentic, with the design of your own educational intervention".
[Obs7]	Activity 3. The main teacher keeps thinking; in this case, how can we know that students have been in a specific place? (with QR codes we can't assure it). An evaluator proposes to use Junaio, but the main teacher doesn't want (it is better not to increase the technological requirements for the students).
[Int1-2]	"To a question regarding whether the teachers had to adapt the learning design to the technology, the main teacher answered, "Well, we adapted it slightly. Mainly, more than in the content, in the methodology, or in what it [the technology] makes possible, or in how the students reach that. (...)Almost always positively. Near the 100% of the cases. And if you control the technology, and you follow your principles about what you want to teach, in the 100% of the cases the adaptation is positive". Also, the assistant teacher answered "We tried [to change the learning design] the minimum possible (...) We took care about it, so that the essence of the course was not altered (...) there are some things that are adapted, but you keep on with your goals, so they [the changes] are things to support them".
[Art6]	Mail from the main teacher the night before to an enactment session, at 2:12 a.m.: "I'm nocturnal and autonomous (...) In my mobile, Junaio works at 97%. I'm sending you a picture and the markers for tomorrow".

4.2.2 Management

The evaluation showed evidence that **the Bucket-Server helped manage the learning situations by unifying in a single element in the VLE multiple learning artifacts generated with different tools and positioned in several spaces using a number of positioning types** (see [Quest1-2]^A and [Int2] in Table 9). The management was also benefited with the bucket feature of showing a single view of the positions of the artifacts in the physical spaces (e.g., a list including all the markers, ready to be copied or printed) (see [Screen2] in Table 9). The teachers also recognized that the automatic creation of artifacts provided by the Bucket-Server was an advantage, allowing them to create instances of different external tools (e.g., Google Docs or Picasa) with a single click within the bucket (see [Screen1] and [Int1]^A in Table 9). Regarding the time demanded by the Bucket-Server, the teachers acknowledged that the time devoted to implement the learning situations using buckets was affordable for them (see [Quest1-2]^B in Table 9). This time was decreasing as the teachers used the buckets in different learning situations along the course (see Table 8).

A limitation for the management of the learning situation was that the Bucket-Server prototype did not include any adapter for questionnaire tools. Due to this fact, several questionnaires were created externally with Google Forms, and added to the buckets as web contents. It would reduce the required time to implement learning situations if the Bucket-

Server prototype would have included a Google Forms adapter (see [Int1]^A in Table 9). Also, the use of two Moodle installations was a disadvantage for the management, since teachers and students had to deal with two Moodle (see [Int1]^B in Table 9). Table 9 shows some excerpts of evidence that illustrate the findings described.

Table 8. Time devoted by the teachers to implement the learning situations in the secondary Moodle, including the time to create activities, buckets and artifacts, as well as the validation time

Learning situation	Implementation time	Supporting data
1. Orienteering	1h36m	[Obs2]
2. Hiking	2h	[Quest2]
3. School paths 1	1h42m	[Screen2]
4. General session in campus	1h3m	[Screen3]
5. School paths 2	45m	[Quest1]

Table 9. Selected excerpts of evidence related to the management orchestration aspect

Data source	Excerpts
[Quest1-2]	^A To the assertion "The learning buckets helped me in the management of the learning situation from its design to its enactment" both, main and assistant teachers answered 5, "Agree". ^B To the assertion "I think that the time dedicated to the implementations using buckets from Moodle is affordable" both, main and assistant teachers answered 5, "Agree".
[Int2]	"(...) everything is gathered up within the same entity, the bucket, you can consult the things, when you have to print, you just click and it gave you the document [with the markers]. So, it helps ... in the speed, the time, the view, ... that's help in the management, to avoid to have to go to 20 places simultaneously to do it (...) it is interesting the tools that the buckets provide, that you just click, it gives you the options, and you choose. You don't need to do more. (...) About organization, you have everything within the same container, you don't need to go to a place to do something, to another place to do something else, and after that print everything... the management is effective. For a teacher, this is convenient".
[Screen2]	The main teacher gets the list with the QR codes and markers (...) and pastes them in a Word document to be able to handle them better (print them, etc).
[Screen1]	The researcher puts the example of creating a Google Docs. The main teacher says: "Very good, so, it creates the Google Docs directly. This way I don't have to do engineering [manual operations]"
[Int1]	^A "What is very nice... obviously, I am accustomed to that, but the QR codes or the Google Docs could not be created automatically. If it were possible that the questionnaires [were created in the same way]. In the end, the questionnaires were web links (...) if they could be created from there [the bucket], or there would be a simple format, configurable with the type of questionnaires that the teacher wants to do, it would be great". ^B "(...) maybe one of the problems is that it is not possible to work in the official University's Moodle, because it is an additional hop. I can't be bothered to do it. then, if it could be implemented there [in the university Moodle], it would be easier to work with the students, and the autonomy, etc".

4.2.3 Adaptation

During the evaluation, the teachers recognized that **the Bucket-Server enabled them to make runtime changes in the learning buckets and in the artifacts within the buckets** (see [Quest1-2]^A in Table 10). However, in the learning situations carried out, **the teachers only modified buckets before conducting the activities (when they created the activities in Moodle), and the teachers and the students modified buckets and artifacts during the activities carried out in Moodle** (see [Quest1-2]^{B,C}, [Obs8] and [Screen2] in Table 10). The teachers did not need to modify anything during the activities conducted in physical spaces

(e.g., in the natural environment), and therefore it was not possible to explore this kind of adaptation. Anyway, the teachers acknowledged that any runtime modification in activities conducted in the natural environment would have been extremely difficult to make real, due to the time restrictions, the large number of students, the characteristics of the physical spaces (e.g., mountains), and the rest of non-technological activities and materials used (see [Quest1-2]^A in Table 10). Table 10 shows selected excerpts of evidence that illustrate the findings described.

Table 10. Selected excerpts of evidence related to the adaptation orchestration aspect

Data source	Excerpts
[Quest1-2]	<p>^A To the assertion “I think that the buckets used from Moodle allow to make changes in the design before, during, and after the activities” the main teacher answered, “Ufff here I need to put something more qualitative. Before, yes, [they allow to do it] without problems; during, it could be done, but it is complicated due to the space and the way of configuring the teaching; after, [they allow to do it] as well, but I don't know what would be the utility apart from recycling it for other occasions. If the question is for before, I put a 6. In other cases, Don't know/no answer”; the assistant teacher answered 4, “Somewhat agree”, and she also explained that “I rated almost everything ‘somewhat agree’ because there are some elements that cannot be modified once the bucket and the activity inside it are created. It would be necessary to remove and reconstruct again, therefore from my point of view it is a matter that could be improved”.</p> <p>^B To the assertion “It was necessary to make modifications in the buckets or their artifacts during the activities” the main teacher answered 1, “Strongly disagree” and the assistant teacher 2, “Disagree”.</p> <p>^C To the assertion “I wanted to do some changes, but it was not possible with the systems” both the main and the assistant teachers answered 2, “Disagree”.</p>
[Obs8]	The students cannot create more artifacts. The assistant teacher realizes the students have reached the 10 maximum artifacts. The main teacher accesses Moodle to change it. (...) The assistant teacher realizes the students have not configured the scale in the images. They start to edit them.
[Screen2]	The main teacher has made a mistake in the name of an artifact. He edits it. (...) The researcher reminds him that the artifact is not positioned in a QR code. The main teacher edits the artifact and configures it. Also, he realizes he didn't put a description, and he adds it too. (...) He forgot also to include the descriptions in the buckets of each group. He edits them, adding a description. (...) The main teacher has added another artifact, but he forgot to geolocation it. He edits the artifact and configures it.

4.2.4 Awareness

During the evaluation study, **the Bucket-Server provided a container with a unified runtime view to enable awareness of the artifacts created by the students** (see, e.g., [Int1] and [Int2]^A in Table 11). But due to the large number of students and the limited available time, **the buckets were not used during the activities in physical spaces to monitor the students' actions, and were scarcely used after the end of the activities to review the students' work** (see, e.g., [Int1] and [Quest1-2]^{A,B} in Table 11). Thus, the buckets were accessed mainly for final assessment purposes. There was an exception in some activities in which the teachers used the bucket as an awareness mechanism, requiring students to upload pictures in buckets in some specific locations, to verify that they had been there (see, e.g., [Int2]^A and [Screen3] in Table 11). The evaluation results indicate that the Bucket-Server prototype should be improved to enable a better use for awareness in activities conducted in physical spaces (e.g., including a global map view, with tracking features and times) (see, e.g., [Int2]^B in Table 11). Table 11 shows some selected excerpts of evidence that illustrate these findings.

Table 11. Selected excerpts of evidence related to the awareness orchestration aspect

Data source	Excerpts
[Int1]	“During the activities, the problem of this kind of content is that while carrying out the activities you have a lot of things to think about, and to do, and to dedicate. (...) In the same way that you were looking at the buckets, I could have done it... but I didn't, but imagine in other activities (...), for instance, in the park (...) we could have seen what pictures they were uploading, (...) give them feedback (...) I think it could serve fine. And regarding the orienteering, [it could be nice] to link [the bucket] with a track, to see the track and comment it in runtime (...) you have to be aware of other things, and you have [the buckets] already there [I can see it later]. Problem of later: it has been a problem of mine, to don't come back to it. I just was thinking in the following thing that we have to do (...). And obviously, it is a repository more, of works and experiences”.
[Int2]	^A “What they [the buckets] can provide me during the activities, (...) if I wasn't advising to 20 students (...) but, yes, if you connect to the Picasa bucket, you can see on the fly where they are uploading pictures, what problems they have in specific locations, you can control the geolocations were they are passing through (...) If you have time to connect to the bucket, it allows you to locate the users”. ^B Asked about possible improvements of the awareness features, the assistant teacher answered “It would be nice that it created the map [of the itinerary followed]. I mean, integrating the runkeeper [tracking app] inside. (...) to include a track. (...) with times, it would be great”
[Quest1-2]	^A To the question “What information did you use to be aware of what the students were doing during the enactment?” the main teacher answered “- Observation. - Consult Moodle. - Ask them” and the assistant teacher answered “I never consulted it in situ. What I saw is through what they were doing” ^B To the question “What information did you use to be aware about what the students have done in the enactment?” the main teacher answered “- Consult Moodle. - shared (collective) assessment after each experience, assessment of their individual reports and their works in group” and the assistant teacher answered “I accessed Moodle or Google Drive”.
[Screen3]	In O-BTT (activity 3), the main teacher wants to know that students were in the marker's location. Since with QR codes in the current implementation it is not possible, he proposes that they take a picture in the marker.

4.2.5 Roles of the teachers and other actors

Evaluation evidence shows that **the Bucket-Server enabled teachers to transfer part of the orchestration load to the students, but it required a previous training of the students, which also increased the teachers' load** (see, e.g., [Quest1-2]^A and [Int1]^A in Table 12). This initial addition of work load for the teacher showed to be an important factor to consider. Thus, in some activities, the instructions of the tasks were not clear for the students, and it required an extra time (mainly from the assistant teacher) during the activities to explain the students what to do (e.g., how to use the buckets). Therefore, an absence of an initial training in the instruments that may help share the orchestration load with the students can conclude in extra orchestration load for the teachers during the enactment, to guide the students. In spite of this, the teachers perceived the bucket constraints as a useful tool to control the degree of flexibility (and coercion) offered to students in the management of learning artifacts, and therefore, to regulate the transference of orchestration load to students (see, e.g., [Int1]^B in Table 12). During the learning activities, such transference of orchestration load was not intensely used, due to the time restrictions, and learning buckets were mostly used to create learning situations across spaces by means of buckets and artifacts created by the teachers themselves (see Table 6). Thus, the sharing of the orchestration load in most of the learning situations consisted in enabling students to create and upload pictures to buckets, except in the general session in campus, in which a group of students created artifacts of different types from within Moodle (see, e.g., [Obs6], [Obs7], [Obs8] and [Screen4] in Table 12). Similarly, the

learning buckets helped the teachers give responsibility to the students in the management of learning artifacts (see, e.g., [Quest1-2]^B and [Int2] in Table 12). This is illustrated in the “School paths” learning situations (see Figure 4), in which the students managed the activities with the children, as well as in the aforementioned preparation of the “General session in campus” (see Figure 4). However, a deeper initial training would have been necessary to achieve more autonomy than the one reached, since several explanations to the students from the assistant teacher and some evaluators were needed during the enactment.

Finally, it is not clear to what extent the learning buckets allowed students to take their own decisions about learning artifacts. When asked about this issue, the teachers gave different opinions (see, e.g., [Quest1-2]^C in Table 12). Both teachers acknowledged that the buckets allow students to take decisions. However, the main teacher specified that the students did not take a lot of decisions in the learning situations actually conducted. He saw that the students did not reach a clear understanding of what was the usefulness of some of the tasks they did (see, e.g., [Quest1-2]^C and [Int1-2] in Table 12). Such understanding could be reached with a deeper initial training than the one carried out, which the main teacher claimed that would be incorporated in the course the upcoming year. Table 12 shows some excerpts of evidence that illustrate the findings described.

Table 12. Selected excerpts of evidence related to the roles of the teachers and other actors orchestration aspect

Data source	Excerpts
[Quest1-2]	<p>^A To the assertion “The learning buckets enable the transference of part of the management load to the students (e.g., to take decisions about artifacts or to make operations over them, such as create or modify them)” the main teacher answered 4, “Somewhat agree” and the assistant teacher 5, “Agree”.</p> <p>^B To the assertion “I think that the systems may allow giving responsibility to the students (by enabling them to take decisions about the artifacts)” both, the main teacher and the assistant teacher answered 5, “Agree”.</p> <p>^C To the assertion “I think the learning buckets may allow that the students take some decisions about the learning artifacts” the main teacher answered 3, “Somewhat disagree” and the assistant teacher answered 5, “Agree”.</p>
[Int1]	<p>^A To a question regarding if the learning buckets enable the transference of part of the management load to students: “Yes, it is very clear. But in the process in which you transfer autonomy or management to the students, in the first phase, it is just the opposite. It is loaded over the teacher. Because the students have to be trained in the design of the issues. We come back to the available time. (...) Then, if you invest a time in training the students, in giving them all the possibilities, enabling them to technologically control it, etc., etc., great, (...) It is about the configuration of the training as a whole. I think that they [the buckets] enable it. Another thing is if we have done it”.</p> <p>^B Asked about the bucket’s configurable constraints, the main teacher answered: “Good. I think the constraints are good, because this way, it is the teacher who decides how far the students can go. And it is more versatile for deciding what you want to work”.</p>
[Obs6]	Another group in front of me is uploading the pictures. Two students are doing it, together with the children. They are doing it and the children watch it.
[Obs7]	The main teacher shows the researcher how he has created the bucket (...) directly from Moodle. In the bucket, the students will put the questionnaires that they are creating. The researcher reminds the teacher that he has to configure the bucket with a positioning type “manual” (so that the students will be able to position the questionnaires with QR codes).
[Obs8]	The assistant teacher explains the different positioning types, with examples of the activities conducted. The students pay attention.(...) A student starts [to add geopositioned questionnaires]. He did it quickly.
[Screen4]	The assistant teacher says that they [the students] can create up to 10 artifacts. The main teacher

	says that he decided it.
[Int2]	Asked about if the learning buckets allow giving responsibility to the students, the assistant teacher answered "Yes, of course they do. (...) Yes. Moreover, I think that they appreciate it. To pass from being a passive subject to an active subject.
[Int1-2]	Asked about their answers regarding if the learning buckets allow the students to take decisions, the main teacher answered "It has to do with how far we have come in this issue with the students. In this real experience, the one of this year. (...) we weren't able to achieve that they understand, in its entirety, what things are useful for. But anyway, it happen in this issue, and in other things a lot of more basic of education (...)". Also, the assistant teacher answered "Of course, we did it. But not in the level we wanted. But I think it is what should be done. Enabling, they [the buckets] enable it, absolutely, moreover, they allow to grant what the student is able (or not) to choose. Sure".

4.2.6 Pragmatism

The evaluation showed that **the Bucker-Server supported the constraints of non-ICT expert teachers in authentic learning situations of their everyday practice, which involved a VLE of the same type of the one of their institution, common Web 2.0 tools, and multiple physical spaces**. Teachers perceived the learning buckets as an interesting and easy-to-use tool to organize positioned learning resources of multiple types, enabling to bring learning everywhere. They also emphasized the contextual and interactivity capabilities of buckets, the integration with Moodle, and the adaptability of buckets to different methodologies and ICT tools (see, e.g., [Quest1-2]^{A,B} and [Int1]^A in Table 13). The Bucket-Server did not restrict the range of applicability, although such range was extending as the teachers learned how to use the buckets. In the end, teachers were able to design and conduct multiple activities, with different social levels (individual, group, class), in several spaces, and using different pedagogies (see, e.g., [Quest1-2]^C and [Int2]^A in Table 13). They perceived many possibilities in the use of learning buckets, acknowledging that they would use buckets again in their educational practice (see, e.g., [Quest1-2]^D, [Int1]^{B,C,F} and [Int2]^A in Table 13). The teachers valued the learning buckets as easy to use, but requiring an initial training for both, teachers and students. During the learning situations, the teachers appropriated the learning buckets, being finally autonomous in their use (see, e.g., [Int1]^{D,E}, [Int2]^B, [Screen1] and [Obs5]^A in Table 13). Since the essence of most of the learning situations did not change from previous years, such situations could have been carried out without buckets. However, the buckets were an added value which enriched them, and the activities would not have been conducted without buckets in the same way that they were. Only some specific activities could have been carried out similarly without buckets, such as those that used one or few QR codes, which could have been implemented with a typical QR code generator. Despite this fact, the Bucket-Server enabled the affordable combination of all the activities (e.g., using geolocation, AR markers, uploading pictures, etc.), implemented from Moodle following a *bricolage* approach (see, e.g., [Quest1-2]^E and [Int1]^F in Table 13).

We detected different issues related to the usability of the prototype's web-based user interface. Thus, some actions, terms used, as well as the possible creation of buckets inside other buckets showed to be confusing (see, e.g., [Quest1-2]^A in Table 13). Other problems detected were that the user interface should include mechanisms to avoid repetitive operations, and that some HTML buttons were not compatible with old iOS and android versions (see, e.g., [Obs5]^B in Table 13). Also, concurrence and efficiency problems of the prototype that affected the delay of the pictures uploading and the time to load the user

interface were solved during the study. A major issue in outdoor spaces was the lack of internet connectivity. Thus, the Bucket-Server should be improved to allow participants to work offline when the internet connection is not working (see, e.g., [Obs3] in Table 13). Anyway, the necessity of a non-technological backup plan was always in the mind of the teachers, since a breakdown of the technology should not ruin a learning situation (sometimes entailing long trips). Also the weather (e.g., rain) is an important factor to consider when using technology in outdoor locations (we used plastic bags to protect the tablets).

Another interesting aspect regarding the pragmatic use of buckets is how they adjusted to the teachers design approach in comparison with using an authoring tool. The participant teachers had used, previously to this study an authoring tool to deploy designs in Moodle, Web 2.0 tools and mobile AR clients¹². They perceived that the use of learning buckets directly from the VLE was more convenient for them than the use of an additional authoring tool (see, e.g., [Quest1-2]^{F,G} and [Int2]^C in Table 13). Also, they did not perceive as advantages some of the theoretical benefits of using a learning design authoring tool, such as the capability of reusing designs (see, e.g., [Obs8] in Table 13). This can be logical, taking into account the way they faced design tasks. The main teacher preferred to change his designs every course, and usually took several last time decisions and actions. Also, the assistant teacher argued that sometimes creating a new design could be preferable to modify an existing one, because in some cases to reconstruct a design may take more time than to start from scratch (see, e.g., [Int2]^D in Table 13). Table 13 shows some excerpts of evidence that illustrate the findings described.

Table 13. Selected excerpts of evidence related to the pragmatism orchestration aspect

Data source	Excerpts
[Quest1-2]	<p>^A The main teacher explained that “[A learning bucket is] an interesting space to store geopositioned learning resources. Interesting to bring learning everywhere. They generate learning contents (orienteering) in our subject. They are easy to use. They are recyclable (...). They allow to store different resources”, and the assistant teacher answered “I like the organization capability, the idea of being a container where everything can be placed. And I want to say also what is not interesting, that is difficult to understand what a bucket inside a bucket is”.</p> <p>^B To the question “What advantages do you think that buckets have in comparison with not using them?”, the main teacher explained that “I think they are an excellent and open support, adaptable to different methodologies and ICT tools, with the possibility of positioning in different places (...)”, and the assistant teacher answered “Storing, order, specificity of the tools to use, easiness of its use with respect to its integration with Moodle”.</p> <p>^C To the assertion “I think that the learning buckets may allow teachers to conduct a wide range of learning activities” both, the main and the assistant teachers answered 6, “Strongly agree”.</p> <p>^D [To the assertion “I would use buckets in my educational practice” both, the main teacher and the assistant teachers answered 6, “Strongly agree”.</p> <p>^E [To the assertion “I would have been able to put into practice the learning situations designed without the learning buckets” the main teacher, answered 2, “Disagree”, and the assistant teacher answered 5, “Agree”. The main teacher specified, “This question is ambiguous, I think that the situations can be carried out, but without the help of the tools they are not the same, and we wouldn't have the same possibilities (and also problems, of course)”. Also, the assistant teacher specified “There have been activities that could have been conducted without buckets, such as the orienteering, in which you just read the QR code linked to a questionnaire. With a QR code generator it would be possible. But for geolocating with AR, the Picasa system, etc., and having everything</p>

¹² More specifically, they used the WebCollage learning design authoring tool (Villasclaras-Fernández, Hernández-Leo, Asensio-Pérez, & Dimitriadis, 2013), and the GLUEPS-AR system (Muñoz-Cristóbal, et al., 2014) to deploy the designs created. Chapters 2 and 3 of the dissertation describe it in detail.

	placed in the same bucket, being able to control the answers is very practical".
	^F To the assertion "Benefits and drawbacks of the two options (authoring tool/buckets from Moodle) that you have used" the assistant teacher answered "Advantages. Authoring tool: To create groups, it is faster with different methodologies. Moodle: Easiness to understand and use it. Drawbacks: Authoring tool: More complexity, and if you know Moodle before, still more. Moodle: For more complex models, it is a little slower".
	^G [To the question "What of the two options you have used (authoring tool/bucket from Moodle) do you prefer and why" the main teacher answered "Without attempting to be conservative, I would prefer the buckets, I'm more familiarized with them".
[Int1]	^A "It is a container of virtual information that you can create previously, you can consult during, you can see after. It is very meaningful and very contextual, because it relates to what you are seeing. It is very interactive, because in the end we are in a physical activity, and previously [to the buckets] we weren't able to interact with that [virtual learning artifacts]".
	^B "I think they provide a lot of possibilities. Just that.., well, contextualizing it to the reality that we have lived, there are also limitations. A lot of them in this case due to the casuistry of the teacher (...) regarding times, ... I really would have liked to have a longer time to reflect (...) I'm convinced that it has many more possibilities that those we have actually been able to transform into activities (...)".
	^C To a question regarding if the learning buckets allow using multiple pedagogical methodologies, the main teacher said: "Yes, I think they allow it absolutely. Another thing is that the systems are not magical. It is the teacher who, depending on his perspective, on his conception about the possibilities of the content, on the available time, and other millions of aspects, who makes it possible. There are systems that prevent it, they do not allow working with different methodologies (...) for instance, a power point is very focus on lecturing, and it stops there. This [the learning buckets] enables you (...).If we did not take enough advantage of it, maybe, but I think it does have [that possibility] with no doubt".
	^D "In the beginning it was a little hard for me, but after that I saw it easy. Obviously, you were helping me".
	^E Asked about if the learning buckets are easy to use for the students, the main teacher answered "(...) Training [is needed], depending on who. Good, I think there are more complicated things. It is not the most intuitive and easiest thing of the world, that's clear, but I think that with a minimal familiarization (...)".
	^F "It is an added value absolutely, and we wouldn't have been able to conduct several things [without buckets], in the way we did, obviously. It is a possibility that we have there, and that we can take it or not".
[Int2]	^A "(...) The designs changed 20 times. We said... for this session the rotation is fixed, no, the students move with freedom... They [the buckets] give you possibilities (...) So, they allow you to use what you want. In the end, you choose more by the activity than by the technology".
	^B "How long it takes? A short time. It is longer in the beginning, of course, till you get it. (...). In the beginning, as everything, it is rare. I don't know what our technological competence is, but I guess it's medium. (...) And [the buckets] from Moodle, were very easy for me. The first tries a little so-so, but after that, perfectly".
	^C "I think it is much easier the use of buckets from Moodle [that using the authoring tool]".
	^D "(...) Sometimes re-editing a thing takes longer than starting it from scratch. (...) We should value this process, what takes longer or shorter. I have almost clear that it's difficult to be able to reuse the same designs in the same way (...)".
[Screen1]	Researcher: "So, this is a bucket". Main teacher: "I see it very easy". Assistant teacher: "Yes".
[Obs5]	^A Geopositioning markers - The main teacher proposes to create 6. Observation: He is appropriating the idea. Provides the idea, and how the artifact can help. He seems to know how to use it and for what. - Main teacher: "How do I call it?" Researcher "It is the name of the bucket". Main teacher "Sure, this is what we can leave to the students". Note: So, he verbalizes what a bucket is, he understands it in his context. He is going to geoposition. The main teacher configures the 6 buckets from the ones created automatically; he includes the changes (group 1, group 2, etc.). He doesn't doubt while he is doing it.
	^B The main teacher doesn't want to do 9 tasks. He is complaining. He proposes that we should create a tool that helps in the repetitive tasks.
[Obs3]	The problems that arose were the bad data connection they had in the previous QR code (...).
[Obs8]	The main teacher comments laughing that we said he can reuse designs, but he changes them every year.

4.2.7 Alignment

During the evaluation, **the Bucket-Server helped connect the different physical and virtual spaces by enabling the creation of and access to positioned learning buckets and artifacts from the different spaces** (see, e.g., [Quest1-2]^A, [Int1]^D, [Int2] and [Screen2] in Table 14). Thus, artifacts created in a space could be accessed from another space. Furthermore, this flow of learning artifacts between spaces occurred in the two directions (see Figure 4 and Table 6), from a physical space to a web one (e.g., collecting geopositioned pictures uploaded to Picasa that were accessed afterwards from Moodle) and from a web space to a physical one (e.g., creating positioned artifacts in Moodle that were accessed using AR from physical locations). The evaluation showed also that the Bucket-Server enabled teachers and students to take advantage of some capabilities of the mobile devices. Thus, it enabled the extension of the VLE to multiple physical spaces due to the mobility provided by mobile devices. It also helped achieve collaborative work, by sharing a tablet between small groups of students (see, e.g., [Int1]^A in Table 14). Finally, it enabled to profit from the sensors of mobile devices (e.g., GPS and camera), thus contextualizing the learning artifacts (see, e.g., [Int1]^A, [Screen2] and [Obs10]^{A,B} in Table 14). The teachers and students created artifacts using three different positioning types in physical spaces: geolocation, QR codes and AR markers (see Table 6). The evaluation evidence showed also that such alignment of the different tools and spaces helped achieve the learning goals. This was caused mainly because the Bucket-Server enriched the learning situations enabling the inclusion of new activities that connected the spaces, encouraging contextual learning (see, e.g., [Quest1-2]^B, [Art6] and [Obs10]^{A,B} in Table 14).

The evaluation showed as well some drawbacks related to the alignment orchestration aspect. The main teacher, although satisfied with the results, detected that the students just learned basic concepts regarding the use of the technology (e.g., AR and mobile devices), to replicate the activities carried out. However, they did not appropriate the possibilities that technology offers beyond the specific activities conducted (see, e.g., [Int1]^B in Table 14). This led teachers to reflect about the number of activities conducted (in some cases maybe too many activities), which should be kept in mind in subsequent years in order to achieve a more meaningful learning (see, e.g., [Int1]^C and [Obs7] in Table 14). Regarding the motivation of the students, they identified initially several technological activities (e.g., the use of QR codes) as "additional work", which aroused a certain rejection. On the other hand, the technology was very motivating for the children in the school paths learning situations (see, e.g., [Obs10] in Table 14). Another issue was the delay produced by some technological faults (e.g., faults in mobile data coverage), which affected the continuity of the activities, as well as the focus and the motivation of the students and the teachers (see, e.g., [Obs4] in Table 14). Finally, the use of two Moodle installations together with the short time available and the large number of students affected negatively the alignment orchestration aspect. The teachers did not have enough time for reflecting about the possibilities of the learning buckets to connect still more the multiple activities that were conducted during the course in different spaces. Thus, several activities of the course were designed to be carried out in a single space (e.g., in the official Moodle), without using learning buckets to connect them with other related activities carried out in other spaces (e.g., physical spaces) (see, e.g., [Int1]^{C,D} in Table 14). Table 14 shows some selected excerpts of evidence that illustrate the findings described.

Table 14. Selected excerpts of evidence related to the alignment orchestration aspect

Data source	Excerpts
[Quest1-2]	<p>^A To the assertion "I think the learning buckets allow to take advantage of the potential of using multiple physical and virtual spaces" both, the main and the assistant teachers answered 6, "Strongly agree".</p> <p>^B To the assertion "The learning bucket helped achieve the learning goals" both, the main and the assistant teachers answered 5, "Agree".</p>
[Int1]	<p>^A To a question regarding if the learning buckets enable teachers to take advantage of the mobility, social interaction, geopositioning and detection of markers capabilities of mobile devices, the main teacher answered "Absolutely. In this one [pointing at mobility], very clearly, they enable us to be and to do things in spaces in which before you cannot ever imagine. Another thing is if you use it or not, if it's detrimental in other aspects, but in this one [aspect], very clearly. Social interaction..., also, but maybe we have not taken advantage of it, but I think that it enables too. (...) The geopositioning, of course. We have found something that can be located in a specific place of the space with specific coordinates, and the technology facilitates it. We could have done it like a treasure hunt, putting a "X" in a map, but we did it in this way. (...) This [the detection of markers] as well, It is very good".</p> <p>^B "It is curious how the students have learnt a lot from what we posed, but there is a lack of learning in what is the real essence of all this. You ask them what is augmented reality and maybe they freak out. (...) The questions of the exam were very easy. Few students didn't answer them correctly. But some of them attributed a super-basic use to Junaio. "Junaio can be used to put labels about animals (...)" They have seen things that can be done, but not what is behind".</p> <p>^C "(...) Problem we faced, the available time, (...) and the ratio technological devices/groups of students. We have had to work in a very overcrowded way, with a lot of students. And to what extent the learning is too much "fu-fu-fu" [fleeting]".</p> <p>^D "Yes, there is continuity. But also, we could make more use of it. Sometimes we have made an interruption".</p>
[Int2]	"(...) the students move from a nearby environment, to a medium one, to a far away one. Then, the buckets have allowed connecting the multiple spaces".
[Screen2]	The main teacher creates some geopositioned artifacts. They are web pages corresponding to elements of the area wherein the activity will be carried out, such as plants, animals and villages.
[Obs4]	The main teacher comments that the coverage [internet connection] is a problem, and it may discourage the students.
[Obs7]	The main teacher says that even with a good weather and with 3G connection, the proposed design would have been almost impossible to carry out. For the activity in the park they are going to make a more conservative proposal, with time in the classroom allowing to work in a more relaxed way.
[Art6]	The school's teachers filled out an assessment form. They highlighted 3 positive aspects, and one of the three was "The use of the ICT". Also, in a field to extend any information they considered, they wrote: "To go in depth in the use of ICT, QR codes, geolocations, simple use of maps".
[Obs10]	<p>^A The route appears augmented. The children can see in the tablets the main species of trees.</p> <p>^B A student explaining trees [to the children]. Student: "Do you see any tree?". Children: "Yeeees". Student: "It is this tree, look at the tablet". Student: "What tree do you want to see?". Children: "This!!!". Afterwards the same, with a bird.</p>

4.2.8 Theories

In this aspect, we have explored if the teachers were able to use the organizational and pedagogical approaches that they wanted to use, and how the inclusion of the Bucket-Server in their practice affected such approaches. During the evaluation we saw that **even though the use of the Bucket-Server allowed teachers to follow their usual *bricolage* approach, they changed their way of organizing the learning situations** (see, e.g., [Quest1-2]^A and [Int1] in Table 15). This was perceived as something expected by the teachers because the Bucket-Server enabled them to include new tools and devices, and including new resources forces to change things. Moreover, they explained that they modify usually their organizational approaches, adapting them to different resources, activities or students (see, e.g., [Quest1-2]^C

and [Int1] in Table 15). This change in the organizational approach was perceived as useful by them, although the inclusion of the new technologies (e.g., mobile devices and AR) to enrich the learning situations demanded an extra effort than as usual (see, e.g., [Quest1-2]^{B,D} in Table 15). The teachers also acknowledged that **the pedagogical essence of the learning situations carried out the previous years was not altered**, but enriched (see, e.g., [Quest1-2]^E and [Art5] in Table 15). They took special care of this fact, in order to avoid overloading the activities with technology and losing the essence of the natural environment. The Bucket-Server enabled them to preserve such pedagogical basis and the spirit of performing learning activities in the natural environment. Table 15 shows some selected excerpts of evidence that illustrate these findings.

Table 15. Selected excerpts of evidence related to the theories orchestration aspect

Data source	Excerpts
[Quest1-2]	<p>^A To the assertion “The learning buckets have forced to organize the work of the students in a different way than as I tend to do it” both, main and assistant teachers answered 5, “Agree”.</p> <p>^B To the assertion “Modifying the way that I tend to organize the students’ work has been useful” both, the main and the assistant teachers answered 5, “Agree”.</p> <p>^C The assistant teacher commented “Sometimes, the things are not white or black. (...) you organize the work in a different manner because you have different resources, and it is useful. But without the resources it could have been also useful. There are changes, you work more competencies, and you have to know when it can or it can not been integrated, because it could also hamper the development”.</p> <p>^D To the assertion “Modifying the way of organizing the students’ work has required an extra effort” the main teacher answered 6, “Strongly agree” and the assistant teacher 4, “Somewhat agree”.</p> <p>^E To the assertion “The learning buckets allowed me to put into practice the pedagogical methodologies that I wanted to use” the main teacher answered 6, “Strongly agree” and the assistant teacher answered 5, “Agree”.</p>
[Int1]	<p>“Yes, I have had to change it (...). Useful? I like a lot to put myself in different situations, circumstances, in every practice. (...) Depending on how are the students, their rhythm, how I see the things are going on (...) there are excellent things of previous years that some groups of students are not going to do in the same way. Then, for what? However, they are going to do their own things”.</p>
[Art5]	<p>Mail from the main teacher: “I think we have to congratulate for yesterday, with all its imperfections and the short time that at least I was able to have, from my point of view, I achieved what I aimed, and I realized more than in other cases the potential of the ubiquity, without touching the essence of the content”.</p>

5 Conclusions

The results of the evaluation show that the Bucket-Server system, and therefore, the learning bucket conceptual proposal, helped the involved teachers in the multiple aspects of orchestration, following a *bricolage* approach in the use of a VLE in several learning situations across different physical and virtual spaces during five months. By using learning buckets, the teachers were able to: *design* and implement with Moodle multiple learning situations involving physical and virtual spaces; *manage* the different learning artifacts, dedicating an affordable time in all the process from design to enactment; *adapt* the designs modifying them when needed; be *aware* of the different artifacts created by the students; share part of the orchestration load with the students, who took an active *role* in the orchestration, with a teacher-controlled creation of their own artifacts; fit with the *pragmatic* constraints of the non-ICT expert teachers by enabling them to use a VLE of the same type than the one of their

institution (Moodle) and common Web 2.0 tools; connect the different physical and virtual spaces thus *aligning* the different resources and tools; and comply with the organizational and pedagogical *theories* of the teachers. With respect to the three orchestration aspects that the learning buckets emphasize: pragmatism, roles of the teachers and other actors, and alignment, the evaluation showed evidence that, as far as we know, the learning buckets overcome the orchestration support provided by the alternative approaches for orchestrating learning situations across spaces using a VLE in a *bricolage* mode. Thus, the learning buckets showed to be a effective, easy-to-use and flexible solution that can be embedded in a widespread VLEs such as Moodle, transforming such VLE in an across spaces learning environment integrated with multiple Web 2.0 tools and mobile AR clients (*pragmatism*). Also, the configurable *constraints* of the buckets showed to be like an “equalizer”, able to “tune” the flexibility offered to the students, and therefore, the orchestration load over the different actors, enabling the teacher a controlled sharing of the load with the students (*role of the teachers and other actors*). Moreover, the evaluation showed that the learning buckets can be a simple instrument to connect the different physical and virtual spaces, by enabling the access from a space to contextualized artifacts created in other space (*alignment*). The positive results and feedback received from the teachers (they both used learning buckets in subsequent learning situations, and the main teacher continued using the learning buckets, on his own and without support, in the following course 2014/2015) encourage us to continue this line of research, aiming to explore how the support of the different orchestration aspects can be enhanced.

The integration of learning buckets with VLEs used in *bricolage* mode can be an interesting alternative to the inclusion of additional authoring tools, especially for those teachers who prefer a *bricolage* design approach. We do not aim to defend that one design approach is better than another, just to explore if in the case of some profiles of teachers, one of the approaches can fit better with their pragmatic constraints. The learning buckets in *bricolage* mode can be an effective solution, which is not conceived to enable on its own the complex pedagogical designs that some authoring tools can create. But in the case studied, it fitted well with the design approach of the teachers involved, and allowed them to create and enact affordably multiple situations across spaces. Further research is necessary to explore in depth what types of profiles may adjust better to different design approaches, and how the level of pedagogical and technological complexity, or the type of tools, may impact in the preferences over an approach.

The evaluation results described show also that the help provided by the Bucket-Server to multiple orchestration aspects presented some limitations. In the study conducted, the main factors that affected negatively the orchestration support were: the use of two Moodle installations; the prototype’s user interface; the lack of support for working offline; the complexity of the subject (Physical Education in the Natural Environment) in terms of mobility and spaces involved; and the rhythm imposed to the teachers by the large number of students, the available time, and the number of activities that they had programmed. We plan to tackle these issues in upcoming research, especially to explore in more depth the possibilities of the learning bucket for sharing the orchestration load with students, including student-centered pedagogies. Further research is needed to propose awareness instruments suitable for this kind of time-demanding and complex ubiquitous scenarios. Also, the awareness support

provided in outdoor scenarios by the Bucket-Server showed to be inadequate for settings such as those studied. Another open issue to explore is the analysis of the use of learning buckets from the point of view of the students. Other lines of future work that are being already explored are the possible combination of the learning buckets with other orchestration systems (e.g., to complement the orchestration support of systems that employ learning design authoring tools), and their utilization as design tools as well as assessment and evaluation instruments in ubiquitous settings.

References

- Alharbi, N. M., Athauda, R. I., & Chiong, R. (2014, November). *A survey of CSCL script tools that support designing collaborative scenarios*. Paper presented at the International Conference on Web and Open Access to Learning (ICWOAL), Dubai, United Arab Emirates.
- Azuma, R., Baillot, Y., Behringer, R., Feiner, S., Julier, S., & MacIntyre, B. (2001). Recent advances in augmented reality. *Computer Graphics and Applications, IEEE*, 21(6), 34-47.
- Balacheff, N., Bottino, R., Fischer, F., Hofmann, L., Joubert, M., Kieslinger, B., et al. (2009). *D1.1 The STELLAR vision and strategy statement* (Final report No. 1.0): STELLAR.
- Berggren, A., Burgos, D., Fontana, J. M., Hinkelman, D., Hung, V., Hursh, A., et al. (2005). Practical and Pedagogical Issues for Teacher Adoption of IMS Learning Design Standards in Moodle LMS. *Journal of Interactive Media in Education*, 1.
- Billinghamurst, M., & Duenser, A. (2012). Augmented Reality in the classroom. *Computer*, 45(7), 56-63.
- Britain, S. (2004). *A Review of Learning Design: Concept, Specifications and Tools. A report for the JISC E-learning Pedagogy Programme*: JISC.
- Cahill, C., Kuhn, A., Schmoll, S., Pompe, A., & Quintana, C. (2010, June). *Zydeco: Using Mobile and Web Technologies to Support Seamless Inquiry Between Museum and School Contexts*. Paper presented at the Proceedings of the 9th International Conference on Interaction Design and Children, Barcelona, Spain.
- Casany, M. J., Alier, M., Mayol, E., Piguillem, J., Galanis, N., García-Peñalvo, F. J., et al. (2012). Moodbile: A Framework to Integrate m-Learning Applications with the LMS. *Journal of Research and Practice in Information Technology*, 44(2), 129-149.
- Cohen, L., Manion, L., & Morrison, K. (2007). *Research methods in education*. Abingdon, UK: Routledge.
- Colazzo, L., Ronchetti, M., Trifonova, A., & Molinari, A. (2003). *Towards a multi-vendor mobile Learning Management System*. Paper presented at the Proceedings of World Conference on E-Learning in Corporate, Government, Healthcare, and Higher Education 2003, Phoenix, Arizona, USA.
- Conde, M. Á., García-Peñalvo, F., Alier, M., Mayol, E., & Fernández-Llamas, C. (2014). Implementation and design of a service-based framework to integrate personal and institutional learning environments. *Science of Computer Programming*, 88, 41-53.
- Conole, G., & Alevizou, P. (2010). *A literature review of the use of Web 2.0 tools in Higher Education* (A report commissioned by the Higher Education Academy): The Open University.
- Cuendet, S., Bonnard, Q., Do-Lenh, S., & Dillenbourg, P. (2013). Designing augmented reality for the classroom. *Computers & Education*, 68, 557-569.
- Chan, T.-W., Roschelle, J., Hsi, S., Kinshuk, K., Sharples, M., Brown, T., et al. (2006). One-to-one Technology-Enhanced Learning: An opportunity for global research collaboration. *Research and Practice in Technology Enhanced Learning*, 1(1), 3-29.

- Delgado Kloos, C., Hernández-Leo, D., & Asensio-Pérez, J. I. (2012). Technology for Learning across Physical and Virtual Spaces. *Journal of Universal Computer Science*, 18(15), 2093-2096.
- Dillenbourg, P., Järvelä, S., & Fischer, F. (2009). The Evolution of Research on Computer-Supported Collaborative Learning. In N. Balacheff, S. Ludvigsen, T. Jong, A. Lazonder & S. Barnes (Eds.), *Technology-Enhanced Learning* (pp. 3-19): Springer Netherlands.
- Dillenbourg, P., & Jermann, P. (2010). Technology for classroom orchestration. In M. S. Khine & I. M. Saleh (Eds.), *New Science of Learning Cognition Computers and Collaboration in Education* (pp. 1-20): Springer New York.
- Dillenbourg, P., & Tchounikine, P. (2007). Flexibility in macro-scripts for computer-supported collaborative learning. *Journal of Computer Assisted Learning*, 23(1), 1-13.
- Dougiamas, M., & Taylor, P. (2003, June). *Moodle: Using Learning Communities to Create an Open Source Course Management System*. Paper presented at the World Conference on Educational Multimedia, Hypermedia and Telecommunications (EDMEDIA), Honolulu, Hawaii, USA.
- Dyson, L. E., Litchfield, A., Lawrence, E., Raban, R., & Leijdekkers, P. (2009). Advancing the m-learning research agenda for active, experiential learning: Four case studies. *Australasian Journal of Educational Technology*, 25(2), 250-267.
- Glahn, C., & Specht, M. (2010, October). *Embedding Moodle into Ubiquitous Computing Environments*. Paper presented at the 9th World Conference on Mobile and Contextual Learning (MLearn2010), Valletta, Malta.
- Grubert, J., Langlotz, T., & Grasset, R. (2011). *Augmented Reality Browser Survey* (Technical Report No. ICG-TR-1101): Institute for Computer Graphics and Vision, Graz University of Technology, Austria.
- Guba, E. G. (1981). Criteria for assessing the trustworthiness of naturalistic inquiries. *Educational Communication and Technology Journal*, 29(2), 75-91.
- Gutiérrez Rojas, I., Crespo García, R. M., & Delgado Kloos, C. (2012, September). *Enhancing Orchestration of Lab Sessions by Means of Awareness Mechanisms*. Paper presented at the Proceedings of the 7th European Conference on Technology Enhanced Learning, Saarbrücken, Germany.
- Hannafin, M. J., & Land, S. M. (1997). The foundations and assumptions of technology-enhanced student-centered learning environments. *Instructional Science*, 25, 167-202.
- Hernández-Leo, D., Nieves, R., Arroyo, E., Rosales, A., Melero, J., & Blat, J. (2012). SOS: Orchestrating Collaborative Activities across Digital and Physical Spaces Using Wearable Signaling Devices. *Journal of Universal Computer Science*, 18(15), 2165-2186.
- Hernández-Leo, D., Villasclaras-Fernández, E. D., Asensio-Pérez, J. I., Dimitriadis, Y., Jorrín-Abellán, I. M., Ruiz-Requies, I., et al. (2006). COLLAGE: A collaborative Learning Design editor based on patterns. *Educational Technology & Society*, 9(1), 58-71.
- Herodotou, C., Villasclaras-Fernández, E. D., & Sharples, M. (2014, September). *The Design and Evaluation of a Sensor-Based Mobile Application for Citizen Inquiry Science Investigations*. Paper presented at the Proceedings of the 9th European Conference on Technology Enhanced Learning (EC-TEL), Graz, Austria.
- Jorrín-Abellán, I. M., & Stake, R. E. (2009). Does Ubiquitous Learning Call for Ubiquitous Forms of Formal Evaluation? An Evaluand Oriented Responsive Evaluation Model. *Ubiquitous Learning: An International Journal*, 1(3), 71-82.
- Kaddouci, S., Peter, Y., Vantroys, T., & Laporte, P. (2010). Coupling Pedagogical Scenarios and Location-based Services for Learning. *Learning Technology newsletter*, 12(4), 11-14.
- Keller, C. (2005). Virtual learning environments: Three implementation perspectives. *Learning, Media and Technology*, 30(3), 299-311.
- Klopfer, E., Sheldon, J., Perry, J., Rosenheck, L., Squire, K., Mathews, J., et al. (2011, July). *Augmented reality games: place-based digital learning*. Paper presented at the Proceedings of the 9th International CSCL Conference, Hong Kong, China.

- Kurti, A., Spikol, D., & Milrad, M. (2008). Bridging outdoors and indoors educational activities in schools with the support of mobile and positioning technologies. *International Journal of Mobile Learning and Organisation*, 2(2), 166-186.
- León Font, E. (2014). *Disseny i desenvolupament d'un mòdul per a la integració del middleware SOS amb Moodle* (Degree Thesis). Barcelona, Spain: Universitat Pompeu Fabra.
- Li, L., Zheng, Y., Ogata, H., & Yano, Y. (2004, September). *A framework of ubiquitous learning environment*. Paper presented at the The Fourth International Conference on Computer and Information Technology (CIT 2004), Wuhan, China.
- Linn, M. C., Clark, D., & Slotta, J. D. (2003). WISE design for knowledge integration. *Science Education*, 87(4), 517-538.
- Looi, C.-K., & Toh, Y. (2014). Orchestrating the Flexible Mobile Learning Classroom. In M. Ally & A. Tsinakos (Eds.), *Increasing Access through Mobile Learning* (pp. 161-174): Commonwealth of Learning and Athabasca University, Vancouver.
- Luckin, R. (2008). The learner centric ecology of resources: A framework for using technology to scaffold learning. *Computers & Education*, 50(2), 449-462.
- Martin, S., Gil, R., San Cristobal, E., Díaz, G., Castro, M., Peire, J., et al. (2009, August). *Middleware for the Development of Context-Aware Applications inside m-Learning: Connecting e-Learning to the Mobile World*. Paper presented at the Fourth International Multi-Conference on Computing in the Global Information Technology (ICCGI '09), Cannes, France.
- Mikroyannidis, A., Okada, A., Scott, P., Rusman, E., Specht, M., Stefanov, K., et al. (2013). weSPOT: A Personal and Social Approach to Inquiry-Based Learning. *Journal of Universal Computer Science*, 19(14), 2093-2111.
- Miles, M. B., & Huberman, A. M. (1994). *Qualitative data analysis. An expanded sourcebook*. Thousand Oaks, California, USA: SAGE Publications Inc.
- Milrad, M., Kohen-Vacs, D., Vogel, B., Ronen, M., & Kurti, A. (2011, July). *An Integrated Approach for the Enactment of Collaborative Pedagogical Scripts Using Mobile Technologies*. Paper presented at the Proceedings of the 9th International Computer-Supported Collaborative Learning Conference, Hong Kong, China.
- Milrad, M., Wong, L.-H., Sharples, M., Hwang, G.-J., Looi, C.-K., & Ogata, H. (2013). Seamless learning: an international perspective on next-generation technology-enhanced learning. In Z. L. Berge & L. Y. Muilenburg (Eds.), *Handbook of Mobile Learning* (pp. 95-108). Abingdon: Routledge.
- Mulholland, P., Anastopoulou, S., Collins, T., Feisst, M., Gaved, M., Kerawalla, L., et al. (2012). nQuire: Technological Support for Personal Inquiry Learning. *IEEE Transactions on Learning Technologies*, 5(2), 157-169.
- Muñoz-Cristóbal, J. A., Prieto, L. P., Asensio-Pérez, J. I., Jorrín-Abellán, I. M., Martínez-Monés, A., & Dimitriadis, Y. (2013, September). *Sharing the Burden: Introducing Student-Centered Orchestration in Across-Spaces Learning Situations*. Paper presented at the Proceedings of the 8th European Conference on Technology Enhanced Learning (EC-TEL), Paphos, Cyprus.
- Muñoz-Cristóbal, J. A., Prieto, L. P., Asensio-Pérez, J. I., Martínez-Monés, A., Jorrín-Abellán, I. M., & Dimitriadis, Y. (2014). Deploying learning designs across physical and web spaces: Making pervasive learning affordable for teachers. *Pervasive and Mobile Computing*, 14, 31-46.
- Neumann, S., Klebl, M., Griffiths, D., Hernández-Leo, D., de-la-Fuente-Valentín, L., Hummel, H., et al. (2010). Report of the Results of an IMS Learning Design Expert Workshop. *International Journal of Emerging Technologies in Learning (iJET)*, 5(1), 58-72.
- Niramitranon, J., Sharples, M., Greenhalgh, C., & Lin, C.-P. (2010, April). *Orchestrating Learning in a One-to-One Technology Classroom*. Paper presented at the 6th IEEE International Conference on Wireless, Mobile and Ubiquitous Technologies in Education (WMUTE), Kaohsiung, Taiwan.

- Orlikowski, W. J., & Baroudi, J. J. (1991). Studying information technology in organizations: Research approaches and assumptions. *Information Systems Research*, 2(1), 1-28.
- Peter, Y., Villasclaras-Fernández, E. D., & Dimitriadis, Y. (2013, July). *ThirdSpace: orchestrating collaborative activities in PLEs for formal learning*. Paper presented at the Personal Learning Environment Conference, Berlin, Germany.
- Prieto, L. P., Asensio-Pérez, J. I., Muñoz-Cristóbal, J. A., Jorrín-Abellán, I. M., Dimitriadis, Y., & Gómez-Sánchez, E. (2014). Supporting orchestration of CSCL scenarios in web-based Distributed Learning Environments. *Computers & Education*, 73, 9-25.
- Prieto, L. P., Dlab, M. H., Gutiérrez, I., Abdulwahed, M., & Balid, W. (2011). Orchestrating technology enhanced learning: a literature review and a conceptual framework. *International Journal of Technology Enhanced Learning*, 3(6), 583-598.
- Prieto, L. P., Wen, Y., Caballero, D., & Dillenbourg, P. (2014). Review of Augmented Paper Systems in Education: An Orchestration Perspective. *Journal of Educational Technology & Society*, 17(4), 169-185.
- Roschelle, J., Dimitriadis, Y., & Hoppe, U. (2013). Classroom orchestration: Synthesis. *Computers & Education*, 69, 523-526.
- Santamarina, R. T., Moreno-Ger, P., Torrente, J., & Manjón, B. F. (2010, July). *CS training: Introducing mobile educational games in the learning flow*. Paper presented at the IEEE International Symposium on Industrial Electronics (ISIE 2010), Bari, Italy.
- Sharples, M. (2013). Shared orchestration within and beyond the classroom. *Computers & Education*, 69, 504-506.
- Sharples, M., & Anastopoulou, S. (2012). Designing orchestration for inquiry learning. In K. Littleton, E. Scanlon & M. Sharples (Eds.), *Orchestrating inquiry learning* (pp. 69-85): Routledge.
- Sharples, M., Sanchez, I. A., Milrad, M., & Vavoula, G. (2009). Mobile learning: Small devices, big issues. In N. Balacheff, S. Ludvigsen, T. de Jong & S. Barnes (Eds.), *Technology Enhanced Learning: Principles and Products* (pp. 233-249). Heidelberg, Germany: Springer.
- Shenton, A. K. (2004). Strategies for ensuring trustworthiness in qualitative research projects. *Education for Information*, 22(2), 63-75.
- Slotta, J. D., Tissenbaum, M., & Lui, M. (2013, April). *Orchestrating of Complex Inquiry: Three Roles for Learning Analytics in a Smart Classroom Infrastructure*. Paper presented at the Proceedings of the Third International Conference on Learning Analytics and Knowledge, Leuven, Belgium.
- Sotsenko, A., Jansen, M., & Milrad, M. (2014, November). *Implementing and Validating a Mobile Learning Scenario Using Contextualized Learning Objects*. Paper presented at the Proceedings of the 22nd International Conference on Computers in Education, Nara, Japan.
- Stake, R. E. (2004). *Standards-based and responsive evaluation*. Thousand Oaks, CA, USA: SAGE Publications Inc.
- Ternier, S., Klemke, R., Kalz, M., van Ulzen, P., & Specht, M. (2012). ARLearn: Augmented reality meets augmented virtuality. *Journal of Universal Computer Science*, 18(15), 2143-2164.
- Trifonova, A., & Ronchetti, M. (2004, August). *A general architecture to support mobility in learning*. Paper presented at the Proceedings of the IEEE International Conference on Advanced Learning Technologies (ICALT 2004), Joensuu, Finland.
- Villasclaras-Fernández, E., Hernández-Leo, D., Asensio-Pérez, J. I., & Dimitriadis, Y. (2013). Web Collage: An implementation of support for assessment design in CSCL macro-scripts. *Computers & Education*, 67, 79-97.
- Weinberger, A., Kollar, I., Dimitriadis, Y., Mäkitalo-Siegl, K., & Fischer, F. (2009). Computer-Supported Collaboration Scripts. In N. Balacheff, S. Ludvigsen, T. de Jong, A. Lazonder & S. Barnes (Eds.), *Technology-Enhanced Learning* (pp. 155-173): Springer Netherlands.

- Wong, L.-H., & Looi, C.-K. (2011). What Seams Do We Remove in Mobile-assisted Seamless Learning? A Critical Review of the Literature. *Computers & Education, 57*(4), 2364-2381.
- Wu, H.-K., Lee, S. W.-Y., Chang, H.-Y., & Liang, J.-C. (2013). Current status, opportunities and challenges of augmented reality in education. *Computers & Education, 62*, 41-49.
- Zhang, B., Looi, C.-K., Seow, P., Chia, G., Wong, L.-H., Chen, W., et al. (2010). Deconstructing and reconstructing: Transforming primary science learning via a mobilized curriculum. *Computers & Education, 55*(4), 1504-1523.
- Zimmerman, B. J. (1990). Self-Regulated Learning and Academic Achievement: An Overview. *Educational Psychologist, 25*(1), 3-17.

Chapter 6

Supporting teacher orchestration in Ubiquitous Learning Environments: A study in Primary Education

This chapter describes the works carried out in the last part of the second cycle of the research process (see Figure 6.1). In Chapters 2, 3 and 4 we presented evaluations of the support provided by GLUEPS-AR and the Bucket-Server to the limitations identified in alternative approaches for orchestrating across-spaces learning situations. Chapter 5 described the evaluation carried out to explore the orchestration support provided by the Bucket-Server in its direct integration with Virtual Learning Environments (VLEs) and Augmented Reality (AR) apps. This chapter completes the evaluation works of the support provided by GLUEPS-AR and the Bucket-Server to orchestrate web and physical spaces, exploring the orchestration support provided by the integration of both systems. Thus, this chapter describes an evaluation study in which a pre-service teacher used GLUEPS-AR integrated with the Bucket-Server in “Orientate!”, a learning situation conducted in a primary school with 18 students. The learning situation involved multiple web and physical spaces, and several exiting technologies. Figure 6.2 marks this evaluation in the general diagram of the thesis. The general template used for the questionnaire employed during the evaluation is included in Appendix C. The content of this chapter was published in the following journal article¹:

Juan A. Munoz-Cristobal, Ivan M. Jorin-Abellan, Juan I. Asensio-Perez, Alejandra Martinez-Mones, Luis P. Prieto, Yannis Dimitriadis, “Supporting Teacher Orchestration in Ubiquitous Learning Environments: A Study in Primary Education”, *IEEE Transactions on Learning Technologies*, vol.8, no. 1, pp. 83-97, Jan.-March 2015, doi:10.1109/TLT.2014.2370634 (<http://ieeexplore.ieee.org/xpl/articleDetails.jsp?arnumber=6955828>)

¹In reference to IEEE copyrighted material which is used with permission in this thesis, the IEEE does not endorse any of Universidad de Valladolid’s products or services. Internal or personal use of this material is permitted. If interested in reprinting/republishing IEEE copyrighted material for advertising or promotional purposes or for creating new collective works for resale or redistribution, please go to http://www.ieee.org/publications_standards/publications/rights/rights_link.html to learn how to obtain a License from RightsLink. If applicable, University Microfilms and/or ProQuest Library, or the Archives of Canada may supply single copies of the dissertation.

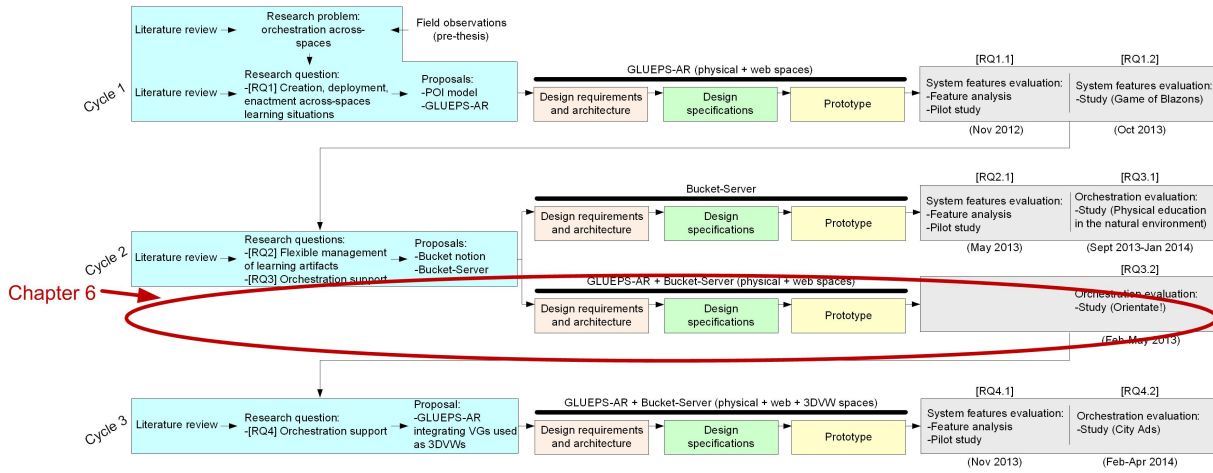

Figure 6.1: Part of the research process covered by Chapter 6.

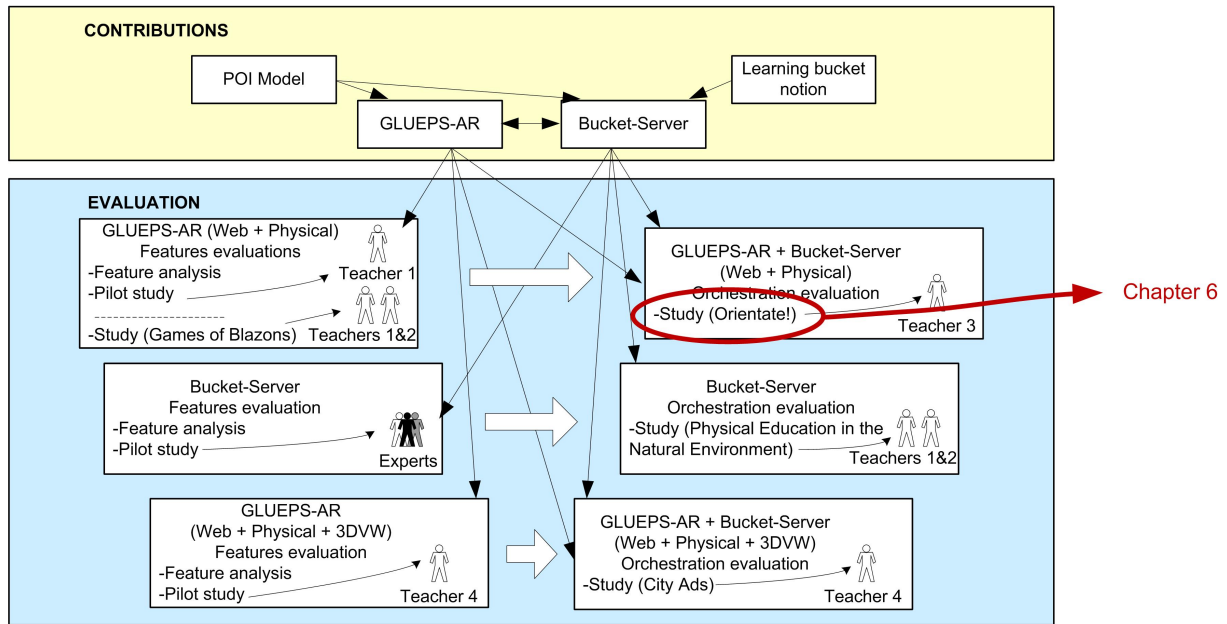

Figure 6.2: Evaluation works covered by Chapter 6.

This is the accepted version of the article, but it has not been fully edited. Content may change with respect to the final publication. Citation information: Juan A. Muñoz-Cristóbal, Iván M. Jorrín-Abellán, Juan I. Asensio-Pérez, Alejandra Martínez-Monés, Luis P. Prieto, Yannis Dimitriadis, "Supporting Teacher Orchestration in Ubiquitous Learning Environments: A Study in Primary Education", IEEE Transactions on Learning Technologies, vol.8, no. 1, pp. 83-97, Jan.-March 2015, doi:10.1109/TLT.2014.2370634 (<http://ieeexplore.ieee.org/xpl/articleDetails.jsp?arnumber=6955828>)

IEEE TRANSACTIONS ON LEARNING TECHNOLOGIES, MANUSCRIPT ID

1

Supporting Teacher Orchestration in Ubiquitous Learning Environments: A Study in Primary Education

Juan A. Muñoz-Cristóbal, Iván M. Jorrín-Abellán, Juan I. Asensio-Pérez, Alejandra Martínez-Monés, Luis P. Prieto, Yannis Dimitriadis, *Senior Member, IEEE*

Abstract—During the last decades, educational contexts have transformed into complex technological and social ecologies, with mobile devices expanding the scope of education beyond the traditional classroom, creating so-called Ubiquitous Learning Environments (ULEs). However, these new technological opportunities entail an additional burden for teachers, who need to manage and coordinate the resources involved in such complex educational scenarios in a process known as “orchestration”. This paper presents the evaluation of the orchestration support provided by GLUEPS-AR, a system aimed to help teachers in the coordination of across-spaces learning situations carried out in ULEs. The evaluation, following an interpretive research perspective, relied on a study where a pre-service teacher designed and enacted an authentic across-spaces learning situation in a primary school. The situation, which illustrates the orchestration challenges of ULEs, was aimed at fostering orienteering skills. It spanned five sessions taking place in the classroom, in the school’s playground and at a nearby park, using multiple technologies and devices. The evaluation showed that GLUEPS-AR helped the teacher in the multiple aspects of orchestration, including implementation of his pedagogical ideas, adaptation in runtime, and sharing of orchestration load with students. Teacher awareness during outdoor activities was the main aspect to improve upon.

Index Terms—Artificial, augmented, and virtual realities, Computer uses in education, Education, Ubiquitous computing, Mobile environments

1 INTRODUCTION

TECHNOLOGICAL advances in the last decades, such as laptops, digital blackboards, Virtual Learning Environments (VLEs) or Web 2.0 tools, are transforming educational contexts into heterogeneous ecologies of technological and social resources [1]. In addition, mobile devices provide new opportunities for learning, both within and beyond the classroom [2]. The use of mobile devices may engage students in knowledge discovery, facilitating the incorporation of pedagogical approaches like active and experiential learning [3]. However, at the same time, these new opportunities for learning are creating even more heterogeneity, generating new barriers or discontinuities across the different learning spaces [4]. Some authors use the metaphor of a “seam” to refer to these discontinuities [5]: a spatial, temporal or functional constraint that forces the user to shift between a variety of spaces or modes of operation [6, 7]. However, technology may also help reduce such seams and transform them into opportunities for learning. Thus, for instance, VLEs

may reduce technological, social and pedagogical discontinuities in classrooms and blended learning [8], mobile devices may help connect classrooms with other physical places [4] and Augmented Reality (AR) may aid to link virtual and physical spaces [6]. Reducing the discontinuities between different physical and virtual spaces may favor seamless learning, i.e., a continuous learning experience across different spaces [9]. This way, the seamless combination of independent physical and virtual learning spaces constitutes a so-called Ubiquitous Learning Environment (ULE) [10, 11].

The difficulties for teachers to put into practice learning activities in technology-supported classrooms and blended environments have been profusely studied in the recent years under the umbrella of the “orchestration” metaphor [12, 13], i.e., the coordination of learning activities in complex authentic educational settings. However, the across-spaces extension of learning situations beyond the classroom generates additional orchestration challenges for teachers [14]. Although there is a growing interest in the orchestration of ULEs [15-17], there is still a dearth of studies regarding the support provided by systems to the orchestration of across-spaces learning situations in ULEs.

The GLUEPS-AR system [18] aims to support teachers in the deployment¹ and runtime management of learning designs, defined using multiple authoring tools [19], in different ULEs. Such ULEs may be composed of wide-

- J.A. Muñoz-Cristóbal, J.I. Asensio-Pérez, A. Martínez-Monés and Y. Dimitriadis are with the GSIC-EMIC Group, School of Telecommunications Engineering, Universidad de Valladolid, Paseo de Belén, 15, 47011, Valladolid (Spain) E-mails: juanmunoz@gsic.uva.es; juase@tel.uva.es; amartine@infor.uva.es; yannis@tel.uva.es
- I.M. Jorrín-Abellán is with the Department of Secondary and Middle Grades Education, Bagwell College of Education, Kennesaw State University, 1000 Chastain Road, MD 0122, Kennesaw Hall, Bldg. #1, Kennesaw, GA 30144-5591 (USA) E-mail: ijorrina@kennesaw.edu
- L.P. Prieto is with the CHILL research lab, École Polytechnique Fédérale de Lausanne, RLC D1 740 (Rolex Learning Center), Station 20, CH-1015 Lausanne (Switzerland) E-mail: luis.prieto@epfl.ch

¹ Throughout this paper, we will use the word “deploy” to mean the setting up of the technological environment.

2

IEEE TRANSACTIONS ON LEARNING TECHNOLOGIES, MANUSCRIPT ID

spread web-based VLEs (e.g., Moodle²), popular Web 2.0 tools (e.g., Google Drive³), and physical spaces augmented with existing mobile AR clients (e.g., Junaio⁴). Previous to the study presented in this paper, GLUEPS-AR had only been used by a teacher to design and deploy an across-spaces learning situation [18]. This design was not put into practice with actual students, and the evaluation focused on the *a priori* planning/preparation of the scenario, and the systematic comparison of GLUEPS-AR features with other technological alternatives. This comparison showed that GLUEPS-AR was able to overcome existing limitations of the reviewed approaches, mainly due to its ability to be employed with multiple authoring and enactment tools, and the support it provides to the flow of learning artifacts between activities conducted in different spaces. To extend such initial evaluation, we present in this paper a study that evaluates, following an interpretive research perspective [20, 21], the support provided by GLUEPS-AR to the *orchestration of a ULE* throughout a complete authentic learning scenario (from its initial conception to the enactment with real students). Such orchestration evaluation is the main contribution of the paper.

Thus, the research question we explore in this paper is: *how does GLUEPS-AR help teachers orchestrate their across-spaces learning situations conducted in ULEs?* In order to illuminate it, we evaluate the teacher orchestration support provided by GLUEPS-AR, in a study involving the design, deployment and enactment of an authentic across-spaces learning situation performed in a primary school and its surroundings. The situation aimed to foster orienteering skills in physical education. It spanned multiple sessions in a ULE formed by different spaces (a wiki-based VLE, a classroom, the school's playground and a nearby park) and using different technologies (an interactive whiteboard, laptops, tablets, Web 2.0 tools, AR, as well as paper and pencil).

The structure of the paper is as follows. In the next section, the learning situation in which GLUEPS-AR was evaluated is described in order to illustrate the complexity and richness of the wide ecology of technological and social resources that shapes ULEs. Section 3 deals with the orchestration metaphor and the GLUEPS-AR system. After that, section 4 describes the evaluation performed, and section 5 discusses the results of the evaluation.

2 ORIENTATE!: AN AUTHENTIC ACROSS-SPACES LEARNING SITUATION

Orientate! Is an authentic across-spaces learning situation conceived and conducted by a pre-service teacher during his *practicum*, involving a sixth-grade class (18 students, about 12 years old) in a public primary school in Valladolid (Spain) and its surroundings. This pre-service teacher worked under the supervision of the in-service teacher responsible for the class. The learning situation was framed within the official prescriptive Spanish cur-

riculum. Since the aforementioned in-service teacher had to assess the pre-service teacher in his practicum, the in-service teacher participated in the learning situation having the main role of an observer, and assisting the pre-service teacher when needed. The main learning objectives of Orientate! were to help students understand orienteering concepts, develop orienteering skills, and use orienteering instruments.

During the learning situation students collaborated in three physical spaces: the classroom, the school's playground, and a nearby public park. Moreover, students were also asked to collaborate through a web space consisting on a VLE in the form of a wiki-site integrating multiple Google Drive documents and other Web 2.0 artifacts. AR and mobile devices were used to bridge physical and virtual spaces, enabling the access, in specific locations of a physical space, to virtual artifacts created in a web space. Thus, the five sessions in which the activity was divided (see Fig. 1) used resources across all these physical and virtual spaces.

The *first session* was devoted to a general introduction to orienteering. The pre-service teacher, using the wiki and Google Drive Slides in the interactive whiteboard, as well as the traditional blackboard, explained some initial issues on how to read maps, use a compass, or the way contour lines are represented in a topographic map. After a 35-minute lecture students were asked to apply what they just learned, in the generation of a classroom sketch-map representing all its physical elements (in three groups of six students). Each group used a tablet and a web whiteboard embedded in the wiki to create the sketches. Afterwards, the pre-service teacher reviewed each sketch with its authors using the interactive white-

	Spaces	Tools	Activities	Snapshot
1 (1,5h)	Classroom Wiki	Smartboard, tablets, wiki Google Slides, webwhiteboard	Introduction to orienteering and sketch of the classroom	
2 (2,5h)	Park Classroom Wiki	Tablets, wiki, Line Brush (digital map), paper & pencil, Picasa	Select elements in a park and place them in map and sketch	
3 (2h)	Playground Classroom Wiki	Tablets, map, AR markers, Junaio, paper & pencil, Google Docs, images, Smartboard, wiki	Orienteering race in playground	
4 (1h)	Classroom Wiki	Paper & pencil, smartboard, wiki, Google Docs, laptops	Prepare questions for final race	
5 (2h)	Park Classroom Wiki	Tablets, wiki, Line Brush (digital map), AR markers, Junaio, paper & pencil, Google Docs, laptops, Picasa	Orienteering race in park	

Fig. 1. The 5-session learning plan

² <https://moodle.org>. Last access October 2014.

³ <http://www.google.com/drive>. Last access October 2014.

⁴ <http://www.junaio.com>. Last access October 2014.

board, and finally the group returned to their desk to revise the sketch using the tablet.

The *second session* took place in a nearby public park. The objectives of the session were to put into practice some of the theoretical concepts seen, and to prepare an orienteering race for a subsequent activity in the park (session 5). Groups were given a tablet, wherein they could access an orienteering map of the park loaded into a drawing application. A different area of the park was assigned to each group. Then, they were asked to select five elements of special interest for them in the assigned zone (e.g., a fountain or a small house to store boats) and to prepare a question regarding each element, to be answered by a different team in the final orienteering race (session 5). They were also asked to draw a paper & pencil sketch-map of the park to situate the chosen elements, as well as to position them in the digital map in the tablet. Back in the classroom, the pre-service teacher took pictures of the sketches, uploading them to Picasa⁵ and the wiki.

The *third session* consisted of an augmented reality orienteering race within the playground of the school. The session was intended to let students practice with orienteering skills and AR in a nearby environment, before the final, more difficult to control, race in the park. Divided in the same groups, students were provided with an orienteering map (in paper). Groups were asked to locate seven AR markers indicated in the map, which were placed all over the playground. Each marker contained a question regarding the orienteering contents seen in the previous sessions. Questions were prepared previously by the pre-service teacher, and were of two kinds: textual (using a Google Drive document linked to the marker) or graphical (using AR to overlay an image onto the marker). Groups also carried tablets with the Junaio AR application, in order to access the questions. Afterwards, in the classroom, the students accessed the wiki using the tablets and the interactive whiteboard, to read a Google Drive document with the correct answers and compare them with their own responses.

The *fourth session* took place in the school classroom, and it was dedicated to the preparation of the final session in the park. Students used laptops to access the wiki and generate a set of questions (each one in a different Google Drive document) regarding the points of interest previously selected in session 2 (e.g., "Which is the color of the roof of the small wooden house near the riverbank?"). These questions were intended to be answered *in situ* by the other groups in the last session.

In the *fifth and last session*, students went back to the park for the final orienteering race. The questions created by the students in session 4 were linked to corresponding AR markers, which were positioned all over the park in the places previously selected by the students in session 2. Group 1 was asked to find markers created by group 2; group 2 had to find the ones posed by group 3, and group 3 had to find markers defined by group 1. Each group used a tablet with the map indicating the location of the

markers, and Junaio to read the AR markers and access the questions created in Google Drive documents. Students were also asked to take a picture of the elements found. Each picture was uploaded to Picasa and to the wiki as an evidence of the group having been there. After the race, back in the classroom, the students used laptops to compare their own responses with the correct answers (placed in the wiki by the teacher).

The learning situation presented above was created, deployed and enacted by a non-ICT-expert pre-service teacher. The scenario involved a web space (a wiki) and three different physical spaces (indoor and outdoor) evolving from the "nearby" classroom to a more "far away" park in the city. This formal learning situation was integrated in the official curriculum and conducted during the official lesson hours. The situation included multiple existing enactment technologies: an interactive whiteboard, laptops, tablets, paper and pencil, a wiki used like a VLE, Web 2.0 tools, a drawing mobile application and a mobile AR client. In the scenario, AR was used to connect the different spaces, e.g., the same Web 2.0 artifacts could be accessed from the wiki (web space) and from different physical spaces using mobile AR. These artifacts were to be created from within different spaces by the teacher and the students.

These characteristics differentiate this learning situation from others reported in the ubiquitous learning literature. There are studies where researchers or ICT-experts set up partially or completely the scenario [22-28]. There are also cases based in a single physical space (e.g., a classroom) [29, 30] or similar kinds of spaces (e.g., multiple indoor ones) [31-33]. Other studies involve informal and/or extra-curricular activities performed with volunteers out of the official hours [17, 34-36]. Yet other scenarios enable the access to artifacts only from certain spaces (e.g., an artifact can be accessed only from a web space, or only from a physical space) or involve collecting data from a physical space to be accessed from a web one [14, 24, 37, 38]. The Orientate! Scenario, on the contrary, was designed by a non-ICT expert teacher, taking into account the constraints of the official curriculum. The scenario spans multiple physical and virtual spaces, and involves accessing artifacts from all these spaces. It illustrates the complexity and richness of a formal scenario integrated in a prescriptive primary education curriculum, involving several spaces and multiple existing technologies. Therefore, we consider the Orientate! scenario itself a second contribution of the paper.

3 GLUEPS-AR: A SYSTEM FOR THE ORCHESTRATION OF ACROSS-SPACES LEARNING SITUATIONS IN ULES

This section introduces the orchestration metaphor and presents the orchestration challenges that scenarios like Orientate! pose. This section also outlines GLUEPS-AR, the orchestration system evaluated through the aforementioned scenario.

3.1 Orchestration

⁵ <http://picasa.google.com>. Last access October 2014.

Dillenbourg and Fischer defined orchestration as “the process of productively coordinating supportive interventions across multiple learning activities occurring at multiple social levels” [39]. The orchestration metaphor has been an important topic in the Technology Enhanced Learning (TEL) research community during the last years (see [40] and [41] as examples of this interest). The conceptualization and scope of orchestration have been profusely discussed: while Dillenbourg restricts orchestration to the enactment of learning situations [42], other authors extend the orchestration scope, covering the whole process from the creation of a learning situation (also known as learning design [43]) to its enactment [44, 45]. The role of the teacher in the orchestration process is also not unanimously established: while some authors consider the orchestration as strongly teacher-centered [12], others emphasize the importance of sharing the orchestration load with students, especially in complex scenarios such as ubiquitous ones [16, 46]. Indeed, a number of authors have proposed conceptual frameworks that describe the different aspects and characteristics of orchestration [12, 47]. Prieto et al., reviewing TEL literature related to orchestration, propose a framework which attempts to be more general and non-restrictive, encompassing the different aspects mentioned within the TEL community under the “orchestration” umbrella [13]. From this work emerges a definition of orchestration as “the process by which teachers and other actors design, manage, adapt and assess learning activities, aligning the scaffolding at their disposal to achieve the maximum learning effect, informed by theory while complying pragmatically with the contextual constraints of the setting” [48]. The framework defines eight aspects that characterize orchestration

(hence its name, ‘5+3 Aspects’ framework): design, management, adaptation, awareness, roles of the teachers and other actors, pragmatism, alignment and theories. The use of the framework as a research instrument was evaluated by Prieto [48], which concluded that the framework provides an integrated view of TEL practice in authentic settings. In spite of its broad conception (derived from its holistic nature) the framework also demonstrated its usefulness as an instrument for guiding research data gathering. This more general approach fits well with our purpose of evaluating the support to orchestration provided by GLUEPS-AR in a ULE, considering the multiple aspects that the different approaches in the TEL community encompass under the orchestration concept.

The ‘5+3 Aspects’ framework can be also used to structure the analysis of the orchestration challenges that ULEs pose in settings like the Orientate! Scenario (see Table 1). Although some of the definitions and conceptualizations of this metaphor stem from work in ubiquitous learning environments [16, 39, 46], so far the detailed analysis of the orchestration challenges in authentic learning situations has been mostly focused on physical classrooms and web-based blended learning [12, 13, 30, 32, 33, 47, 49, 50]. An exception is the work reported by Looi and Toh [17], who explored how the use of students’ mobile devices in science courses affects orchestration. However, their study focused mainly on the activities happening inside the classroom. Also, Sharples and Anastopoulou reflected about the orchestration challenges in inquiry based learning situations where the activities out of the classroom consisted in collecting data to be analyzed later on in the classroom [51].

TABLE 1. CHALLENGES FOR THE ORCHESTRATION OF ULES

Orchestration aspects [13]	Challenges	Examples in Orientate! scenario
Design	Preparing the activities to be implemented with multiple technologies in multiple spaces	The scenario was challenging (even at a conceptual level) for a non-expert, non-technical teacher, due to the multiple technologies and spaces involved: what tool should be used to create the sketch, what device will students use...
Management	Regulating efficiently the across-spaces learning situation and its technological and social resources	There were several artifacts that had to be created and used by the teacher and the students in multiple spaces and with different devices and technologies (e.g., the questions placed along the orienteering race)
Adaptation	Providing efficient ways to modify the learning design and the access to its artifacts from different spaces, in runtime	Some artifacts did not have to be accessible from a certain space (e.g., answers to questions in the wiki) until the activity in another space was finished (e.g., in the park). Outdoor activities can be affected by extraneous events like the weather, the Internet connectivity, etc.
Awareness	Providing teachers with information about what is occurring and what has happened in different spaces	The teacher needed to know, during and after the end of the activities, what the students had accomplished in different spaces using multiple technologies (e.g., which questions had been created, which photos had been uploaded)
Roles of the teachers and other actors	Sharing the orchestration load with students, allowing a certain level of self-regulation	Students designed orienteering routes for another group of students, and created and uploaded several artifacts to be used in subsequent activities in multiple spaces (e.g., race questions)
Pragmatism	Complying with the participants’ contextual and institutional constraints	The scenario followed the prescriptive curriculum (e.g. starting with nearby experiences and progressively expanding to more far away ones), the official schedule of the school, and was carried out by participants not expert in ICT
Alignment	Coordinating the resources in different spaces to attain the learning goals	In the scenario, several devices and technologies were coordinated in a continuous learning experience across different spaces, toward the educational goal of developing orienteering skills
Theories	Using the appropriate orchestration and pedagogical theories that correspond to the scenario and the teacher preferences	The pre-service teacher used his preferred pedagogical and organizational approaches. For example, he maintained typical orienteering activities based on the use of markers, and he selected existing AR and Web 2.0 tools to connect such activities with others in different spaces

AUTHOR ET AL.: TITLE

5

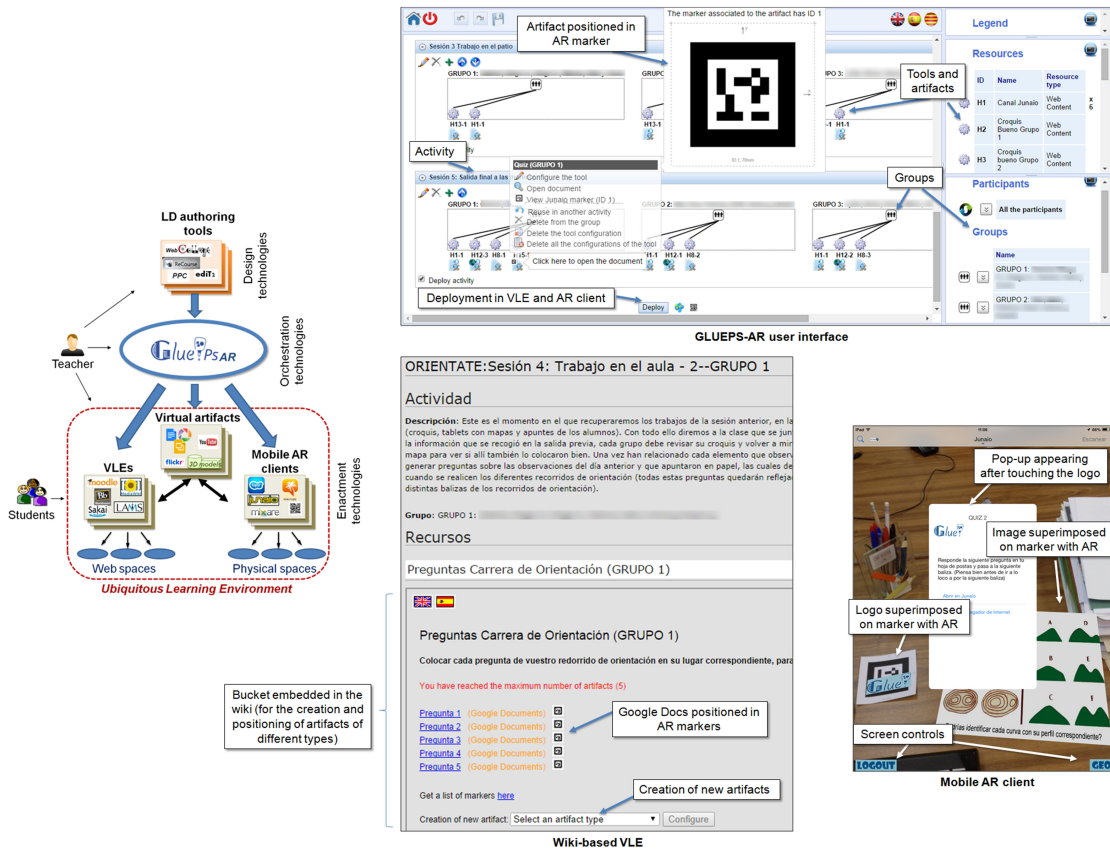

Fig. 2. GLUEPS-AR orchestration system (left), and user interfaces of GLUEPS-AR and enactment technologies (right)

Table 1 shows a number of orchestration challenges that ULEs may pose to teachers, categorized following the '5+3' orchestration framework and illustrated with examples of the Orientate! Scenario. Although similar to those of learning activities in classrooms and blended learning, in ULEs their complexity increases due to the involvement of new spaces and technologies. Also, students may play an important role in these settings since they may help reduce teacher orchestration load, e.g., by managing their own learning artifacts. The evaluation of the support provided by GLUEPS-AR to these orchestration challenges (which are illustrated with the Orientate! scenario) is the main contribution of this paper.

3.2 The GLUEPS-AR System

Multiple technological systems have been developed with the specific purpose of helping orchestrate learning situations [15, 16, 45]. GLUEPS-AR [18] does so for the case of across-spaces learning situations conducted in ULEs (see Fig. 2). GLUEPS-AR is able to deploy the teachers' pedagogical ideas (i.e., their learning designs [43]) expressed using multiple existing authoring tools [19], in different ULEs. Such ULEs may be composed of existing well-known VLEs (e.g., Moodle, wiki-based ones) and existing mobile AR clients (e.g., Junaio, Layar⁶, or any common QR code reader). In addition, GLUEPS-AR enables the access to virtual artifacts (e.g., web pages, 3D models, or artifacts generated with Web 2.0 tools, like Google Drive documents) from both VLEs and AR clients. Fig. 2 includes screenshots of the user interfaces of GLUEPS-AR and the enactment tools employed in the Orientate! Scenario: a wiki-based VLE and the Junaio mobile AR client. As the figure illustrates, teachers have access to GLUEPS-AR user interface, as well as to authoring and enactment tools. Students do not have access to the GLUEPS-AR user interface (they only use the enactment tools). The

- ✓ **Design:** Modification/completion and automatic deployment in ULEs of learning designs created in multiple authoring tools (not necessarily supporting multiple spaces)
- ✓ **Management:** Structuring of activities, groups and learning artifacts, as well as positioning in different spaces. Automatic creation of tool instances
- ✓ **Adaptation:** Changes in learning design during runtime, including properties such as accessibility or positioning in a certain space
- ✓ **Awareness:** Centralized control panel wherein all created artifacts can be monitored and accessed
- ✓ **Roles:** Students' self-regulation of learning artifacts positioned in different spaces during enactment by means of learning buckets embedded in ULEs
- ✓ **Pragmatism:** Possible use of several existing VLEs and AR clients
- ✓ **Alignment:** Integration of physical and web spaces by enabling the access to virtual artifacts from VLEs and AR clients
- ✓ **Theories:** Possible use of existing authoring and enactment tools compliant with the teacher preferred organizational and pedagogical approaches

Fig. 3. GLUEPS-AR orchestration features

⁶ <http://www.layar.com>. Last access October 2014.

TABLE 2. DATA GATHERING TECHNIQUES

Technique	Description	Purpose
Collection of participant-generated artifacts (Art)	Collection of a diverse set of electronic artifacts generated by the teacher and the students, and digitalization (e.g., pictures) of non-electronic ones. Types of data collected include emails, learning designs and products, students' notebooks, teacher reflections.	Registering the learning design process, as well as the use of GLUEPS-AR, the wiki and the mobile AR client by the participants. Being aware of the teacher's asynchronous activities. Gathering the opinions of the pre-service teacher and the students. Complementing the observation of the enactment with information of the learning artifacts generated.
Screen recording (Screen)	Recording, using specialized software, of the actions conducted in the computer by the teacher during the training and the deployment sessions, as well as the actions of the evaluation team during the deployment validation session.	Understanding the design and deployment processes, and measuring the amount of time that these processes require.
Observation (Obs)	Naturalistic, semi-structured observations during the training and deployment sessions, as well as during the enactment. The observations were guided by an anticipatory data reduction schema (see Fig. 3), and conducted by up to five different experienced observers (at least three in each enactment session). The data collected were audio/video recordings, pictures and observation notes.	Registering the actions, impressions and other emergent issues of the teacher during the training and the deployment sessions, and of the teacher and the students during the enactment. Recording the actions and impressions of the evaluators during the deployment validation.
Questionnaire (Quest)	Qualitative, web-based exploratory questionnaire, designed in an iterative review process by 5 evaluators and 1 external researcher. It was composed of open-ended and closed items (6-point scale [1=strongly disagree, 2=disagree, 3=somewhat disagree, 4=somewhat agree, 5=agree, 6=strongly agree]).	Getting the initial opinions of the pre-service teacher over a wide range of matters before conducting the interview.
Interview (Int)	Qualitative, semi-structured, face-to-face, one-to-one conversation with the pre-service and the in-service teachers (recorded and transcribed).	Capturing the opinions of the teachers in depth, after an initial analysis of other data sources (e.g., observation data, questionnaire answers, etc).

figure also shows the main elements of the involved user interfaces. Fig. 3 lists the main orchestration support features of GLUEPS-AR, grouped by orchestration aspect.

Up to now, GLUEPS-AR has had a strong teacher-centered perspective, lacking any kind of runtime flexibility for students to self-regulate their learning artifacts [18]. This limitation can be especially severe in ULEs, since the complex learning artifact management may entail a great orchestration load for the teacher [16]. In order to allow a certain degree of flexibility and student self-regulation during enactment, while retaining pedagogical control by the teacher, we have extended GLUEPS-AR to implement the concept of *learning buckets* [46]. A learning bucket is a container of tools and artifacts that GLUEPS-AR embeds in the VLE or AR client (Fig. 2 depicts a bucket embedded in a wiki). The bucket is defined and configured by the teacher at design-time. At runtime, using the bucket, the teacher and the students are able to create artifacts of different kinds (e.g., a photo, a Google Drive document). These artifacts can be positioned in physical or web spaces (e.g., geolocated in a physical space to be accessed in a subsequent activity using AR).

In order to explore to what extent GLUEPS-AR provides orchestration support for teachers in cross-spaces learning situations, we evaluated its use in the Orientate! scenario.

4 EVALUATING THE ORCHESTRATION SUPPORT FOR TEACHERS OF GLUEPS-AR

This section describes the evaluation study performed to explore the research question driving our work: *How does GLUEPS-AR help teachers orchestrate their across-spaces learning situations conducted in ULEs?*

The evaluation relied on a qualitative research study

[20] wherein the Orientate! learning situation described in section 2 was designed, deployed and enacted using GLUEPS-AR. This study took place from February to May, 2013. As mentioned above, the teachers involved were a pre-service teacher (leading the whole design and enactment process), and the in-service teacher in charge of the class (who assessed the pre-service teacher in his *practicum*, and hence, participated in the enactment observing, suggesting and supporting him). The class was formed by 18 sixth-grade students (around 12 years old).

4.1 Evaluation Method

To conduct the evaluation, we have followed the Evaluand-oriented Responsive Evaluation Model (EREM) [52], using several data gathering techniques. The EREM is a framework conceived as an evaluation model for a wide range of ubiquitous collaborative learning scenarios. It relies on a responsive evaluation approach [53], strengthening the idea of conducting evaluations centered in the phenomena to be evaluated (evaluand) rather than in the field of expertise of the evaluators (e.g., human computer interaction, didactics, etc). This evaluation method follows an interpretive research perspective [21] that does not pursue statistically significant results or generalizations. Rather, it aims at a deeper understanding of the concrete phenomena under study [54], in our case, the orchestration support provided by GLUEPS-AR for teachers performing across-spaces learning situations in ULEs.

To explore the research question, the evaluation team conducted an anticipatory data reduction process [55] during the evaluation design (see Fig. 4), using the '5+3' orchestration framework as a basis to characterize orchestration. Thus, an *issue* was defined as the main conceptual organizer of the evaluation process: *How does GLUEPS-AR help the participant teacher orchestrate his across-spaces*

AUTHOR ET AL.: TITLE

7

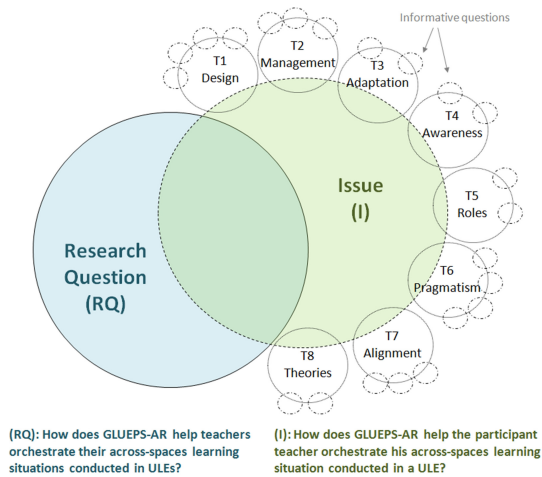

Fig. 4. Anticipatory data reduction showing research question (RQ), issue (I) and topics (T)

learning situation conducted in a ULE? Such issue, centered in the study of orchestration, was divided into eight more concrete *topics* to help us understand the different dimensions within the issue. These topics match the eight aspects the ‘5+3’ framework uses to model orchestration: *design, management, adaptation, awareness, roles of the teachers and other actors, pragmatism, alignment and theories*. In the same fashion, each topic is explored through various informative questions. The schema “research question – issue – topics – informative questions” (see Fig. 4) also guided the data collection during the evaluation, which was carried out using a profuse set of data sources. Table 2 describes the different data gathering techniques employed, and their purpose in the evaluation process. During the data analysis, a single member of the evaluation team coded the data sources using the same anticipatory data reduction schema as an initial category tree thus predetermining the initial set of codes to use *a-priori* [55].

Finally, the evaluation team jointly interpreted the data and identified the findings.

We have used different strategies to ensure the quality of the research process, attending to our qualitative perspective. To increase the credibility, transferability, dependability and confirmability of our research [20, 54, 55], several approaches were followed: prolonged engagement during four months of work with the pre-service teacher and persistent observation in the field; acknowledgement of participant opinions, by interviewing the teachers and by analyzing teachers’ and students’ reflections on the teacher diary and the students’ notebooks; integration of the thorough collaborative observation reports in a single portfolio, thus enabling a thick description of the phenomenon under scrutiny, reported in detail to the whole evaluation team; peer review within the evaluation team to avoid bias; triangulation of data sources, methods and researchers to cross-check data and interpretations. The triangulation of researchers was conducted by involving in the evaluation team experienced researchers with distinct perspectives (i.e., with pedagogical or technological background). Such researchers participated conducting independent observations, which were compiled and discussed in a joint collaborative multimedia report for each session. The triangulation of methods involved the usage of several data gathering techniques (questionnaire, interview, etc). The triangulation of data sources was carried out employing multiple data sources and informants, ensuring that each finding was corroborated by multiple pieces of evidence of different types. We have adopted a descriptive style to report the research and its results, with a detailed account of the context, participants and learning situation, as well as of the evaluation design and its implementation, including the data gathering techniques employed. Such detailed account is another strategy typically employed in qualitative research to achieve credibility and transferability of the results.

Fig. 5 shows the evaluation process, which has been

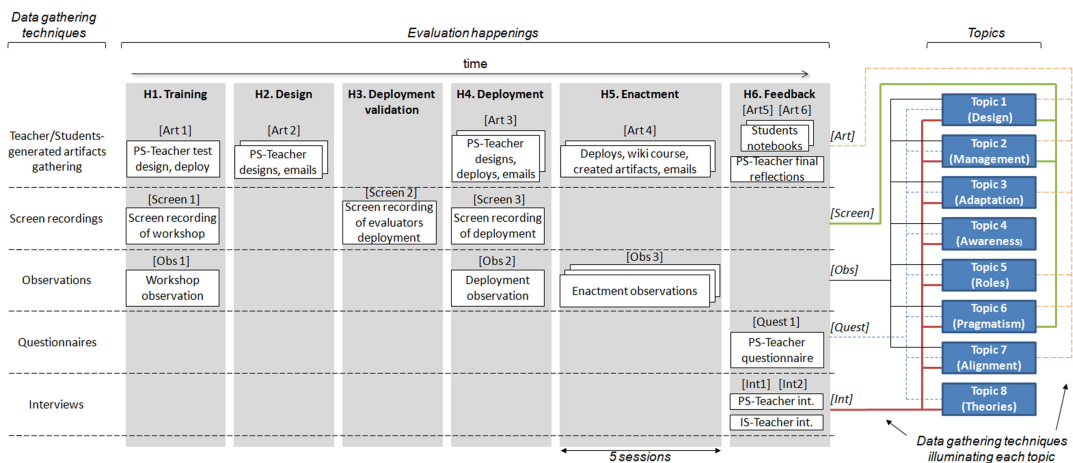

Fig. 5. Evaluation happenings, topics, and data gathering techniques (see Table 2) used during the evaluation

divided into happenings (evaluation events), in which different data gathering techniques were used (along with the labels used to refer to them throughout the text). The overall evaluation process started in February (H1), when an initial 2-hour training session of GLUEPS-AR was performed with the pre-service teacher. After the session, and during two weeks, the pre-service teacher accessed GLUEPS-AR by himself (with occasional support of one of the evaluators), performing tests and deploying learning designs in a Moodle VLE and Junaio AR client. Once he was aware of the affordances of the system, he designed a learning situation (H2) and decided to use a wiki-site as the VLE for the learning situation. Then, the evaluation team deployed the pre-service teacher's design across the wiki-site of the course and Junaio, in order to verify the deployment process, and for time-measurement purposes (H3). In a subsequent happening (H4), the pre-service teacher himself deployed the learning design using GLUEPS-AR. He did so in two steps: 1) he did a partial deployment of the design in a room prepared for data gathering, with the support of the evaluators (using Pedagogical Pattern Collector⁷ [56], PPC, as the authoring tool); 2) he completed afterwards the design on his own (remotely), re-deploying it several times using GLUEPS-AR to fine-tune the resulting wiki, with sporadic support from one of the evaluators. Then, the enactment of the described learning situation was conducted during five different sessions spanning three weeks (H5) in April and May. Finally, feedback from the in-service and pre-service teachers, as well as from the students, was gathered through a web-based questionnaire, two interviews, a document with the pre-service teacher's reflections and the students' notebooks (H6).

4.2 Results

This section summarizes the main results obtained in the evaluation, following the topic structure of the anticipatory data reduction process (see Fig. 4). Since such topics correspond to the different aspects of the '5+3' orchestration framework, they enable us to explore how GLUEPS-AR provides orchestration support. In the next subsections, each orchestration aspect is introduced paraphrasing its definition from the '5+3' framework [13], followed by a discussion of the main related findings and limitations. The main findings and limitations related to all topics are compiled and summarized in Table 3 and Table 4. Both tables include pointers to the data sources that support the findings (using the same labels as in Fig. 5), thus exemplifying the triangulation process followed throughout this study. Due to space restrictions, only a selection of excerpts of these data sources is presented in section 4.

T1. Design

The design aspect of orchestration refers to the planning of the learning activities. It includes both the conceptualization and creation of learning designs (e.g., through authoring tools, or directly in the enactment platforms).

⁷ <http://web.lkldev.ioe.ac.uk/PPC/live/ODC.html>. Last access October 2014.

The evaluation showed that **GLUEPS-AR enabled the non-ICT-expert pre-service teacher to deploy his across-spaces learning designs in different ULEs**. He deployed different across-spaces learning situations with GLUEPS-AR into ULEs using Moodle [Art 1, Screen 1, Obs 1] and a wiki [Art 3, Screen 3, Obs 2] as VLEs. He also reported in the questionnaire as well as in the interview that GLUEPS-AR allowed him to "make real" his conceptual design (e.g., he answered 6, "Strongly agree", in a 1-6 scale to the assertion "With the systems used I was able to deploy a learning design involving multiple virtual and physical spaces" [Quest 1]; in an interview, he answered "[...] it [GLUEPS-AR] helped me a lot. Apart from the tools that I was able to use to put the activities into practice, it also supported me in creating a wiki [course], and have all the activities organized" to a question regarding the support provided by GLUEPS-AR to the design and enactment of the activities [Int 1]). The pre-service teacher also reported, both in the questionnaire and the interview, that he would not have been able to deploy and conduct his learning design in the ULE without GLUEPS-AR (he answered 2, "Disagree", in a 1-6 scale to the assertion "I would have been able to perform the learning situation without GLUEPS-AR", explaining his response: "I don't know another way of putting together all tools that were integrated, and in a same wiki" [Quest 1]; in the interview, he explained "I wouldn't have been able [without GLUEPS-AR]. I guess that there may be other methods for creating wikis, such as wikispaces [...], but with wikispaces [...] I think it wouldn't have provided so many possibilities like GLUEPS-AR does" [Int 1]). Thus, the pre-service teacher did not have severe problems to transform, with the help of GLUEPS-AR, his conceptual design into a deployed course in the ULE. The creation of the course, however, required a certain previous effort to review other across-spaces designs and to test GLUEPS-AR so as to be aware of its possibilities. This conceptualization part was the most challenging for him.

T2. Management

This orchestration aspect refers to the regulation of the learning activities, which involves issues related to the management of the classroom, time, groups, tools or artifacts. The pre-service teacher indicated that **GLUEPS-AR helped him to manage the whole learning situation, from design to enactment**. Thus, for instance, he answered 5, "Agree", and 6, "Strongly agree", in a 1-6 scale, to the assertion "The systems used helped me to manage the learning situation from its design to its enactment", and to the same assertion regarding the management during enactment, respectively [Quest 1]; in the interview, he specified "It allows to create various groups in every activity. Then, you can define a different artifact for every group. The setup of the resources is also very interesting, for instance, Google Docs, which could be reused in the next activity. You do not need to do it again. What you did in the first activity could be directly reused in the other. This helps you save a lot of time" [Int 1).

An important aspect of management is the time a teacher spends in the implementation of a scenario. The pre-service teacher spent 3h 42min in the first phase of

AUTHOR ET AL.: TITLE

9

TABLE 3. FINDINGS OF THE EVALUATION PROCESS

Topic	Findings	Supporting data
Design	GLUEPS-AR enabled a non-ICT-expert teacher to deploy his across-spaces learning designs in different ULEs	Art 1, Screen 1, Obs 1, Art 2, Screen 2, Obs 2, Art 3, Screen 3, Quest 1, Int 1
Management	GLUEPS-AR helped the pre-service teacher to manage the whole learning situation, from design to enactment	Screen 2, Art 3, Screen 3, Obs 2, Quest 1, Int 1
Adaptation	GLUEPS-AR supported the adaptation of the design before, during and after the enactment sessions	Art 4, Obs 3, Art 6, Quest 1, Int 1
Awareness	GLUEPS-AR allowed the pre-service teacher to be aware of the students' actions at the web space during and after the end of the activities, and of the students' performance at the physical space after the activities had finished	Obs 3, Quest 1, Int 1
Roles	GLUEPS-AR provided students with a certain degree of flexibility to self-regulate their learning artifacts, allowing the pre-service teacher to share the management load with them	Obs 3, Art 5, Art 6, Quest 1, Int 1
Pragmatism	GLUEPS-AR complied well with the constraints of the pre-service teacher, the institution, and the educational contexts involved	Art 1, Screen 1, Obs 1, Art 2, Art 3, Screen 3, Obs 2, Obs 3, Quest 1, Int 1
Alignment	GLUEPS-AR enabled the creation of a ULE combining the different physical and virtual spaces, helping achieve the learning objectives and the engagement of the students	Obs 3, Art 5, Quest 1, Int 1, Int 2
Theories	GLUEPS-AR allowed the pre-service teacher use the pedagogical and organizational approaches he wanted to use	Quest 1, Int 1

the design and deployment, and reported 24 hours in total devoted to the implementation of the learning situation [Art 3, Screen 3, Quest 1]. This included the time spent with PPC and GLUEPS-AR to design and deploy the initial idea, and the time dedicated to modifications and revisions using GLUEPS-AR and the wiki during the enactment sessions. These numbers contrast with the time dedicated by a member of the evaluation team to deploy the same learning design (53min) [Screen 2]. The difference between these two time lengths is very large, and we sought to understand the reasons for this difference by analyzing the observations and the final interview with the pre-service teacher. It was found out that this extra time could be attributed in part to the initial learning curve of GLUEPS-AR, and mainly to the fact that the pre-service teacher worked out the conceptual design in parallel to the deployment and enactment of the activities (e.g., the first 1h 4min of the deployment session were devoted to reflect about the design and the options for its technological implementation [Screen 3]; in the deployment session it was observed that the pre-service teacher still needed to clarify his ideas: *"There is discussion about how does the teacher implement the routes (with geolocation, with markers, etc). It seems that the pre-service teacher is not sure about the concrete implementation yet"* [Obs 2]). In spite of this long time, the pre-service teacher reported that *"The time, in the end, is not much time. It is only that at the beginning it is difficult to learn how to manage everything. For instance, things related to the buckets. But when you learn, it doesn't take a lot of time. Actually, it is totally worth it"* [Int 1].

T3. Adaptation

Teachers should have support for adapting the design to different contexts, and in the face of emergent circumstances during the learning activities themselves. Evaluation showed that **GLUEPS-AR supported the adaptation of the design before, during and after the enactment sessions**. Throughout the five enactment sessions, several expected and unexpected events occurred, which re-

quired changes using GLUEPS-AR. For instance, the pre-service teacher positioned some artifacts in a physical space to be accessed using AR, making them not accessible from the wiki (sometimes on purpose, sometimes by mistake); however, students required access to such artifacts in the classroom. The pre-service teacher just modified the accessibility of the artifacts in GLUEPS-AR and re-deployed (e.g., *"The pre-service teacher accesses GLUEPS-AR to modify the learning design and deploy it again. He does it in less than four minutes"* [Obs 3 - Session 3]; *"[...] again, we had to modify things in the platform, because there were hidden resources"* [Art 6 - Session 5]). This runtime adaptability of the visibility of the design elements from different spaces was critical during the Orientate! scenario. Aside from this kind of enactment-time changes, the pre-service teacher changed and adjusted several times the learning design before and between the enactment sessions [Art 2, Art 4]. This was acknowledged by the pre-service teacher in the questionnaire (he answered 5, *"Agree"*, in a 1-6 scale to the assertion "I think GLUEPS-AR allows to perform unexpected changes during the learning activities", and he specified that *"Aside from making changes during the activities, there is a possibility of performing modifications before and after the end of the activities [...] In addition, making changes on-the-fly avoided setbacks and even the cancellation of part of the activities"* [Quest 1]).

Regarding adaptation support, the main limitation was found in **GLUEPS-AR's user interface (employed by the teacher for orchestrating)**, as it was not usable in mobile devices (due to the version of the Javascript framework used). Thus, certain modifications regarding unexpected events during the fifth session in the park had to be performed remotely using a PC, instead of on site using a tablet (e.g., *"[...] the group that did not perform the task in the right way had confused places in the map of their zone, and some marker contents didn't match with points in the map. Thus, one of my colleagues-observers had to call one of his colleagues, to change everything from his computer"* [Art 6 - Session 5]).

74. Awareness

Teachers need to be aware of what is happening (or has happened) in a learning activity. This information may help intervene in case something goes wrong, to provide formative assessment, or to evaluate what is going on. Awareness can be provided *during* and *after* the end of the activities. The evaluation showed that **GLUEPS-AR allowed the pre-service teacher to be aware of the students' actions at the web space during and after the end of the activities, and of the students' performance in the physical space after the activities had finished.** The pre-service teacher answered 5, "Agree", in a 1-6 scale, to assertions regarding whether he considered that the system allowed him to be aware *during* the activities about what students were doing in virtual spaces, and *after* the end of the activities about what students were doing in physical and virtual spaces; also, in the interview, he explained that "when activities are being performed in web sites, yes [I am aware], because, using the teacher's view, I manage directly all the groups, and [...] while everybody is creating question 2, I am able to enter in every group and see question 1 from the teacher view [...]" [Int 1]. The wiki created with the help of GLUEPS-AR acted as a kind of control-panel, since it compiled the resources created in different spaces (e.g., he asserted "[...] access the wiki again, and it allowed me to see if they had uploaded all the pictures [...], this even after finishing the activity, when the children were resting [...]. While they are working in the web space and after the end of the activities in physical spaces it is easier to control them" [Int 1]; in addition, it was observed that "The pre-service teacher is uploading the maps in the tablets' gallery and taking pictures of the paper sketch-maps, uploading them too. This way, everything is automatically integrated in the wiki" [Obs 3 - Session 2]). Nevertheless, although the wiki and GLUEPS-AR enabled the pre-service teacher to structure and access the different artifacts generated by students, he did not have much time during the sessions to monitor the activity of the students through these systems. The evaluation showed also that **GLUEPS-AR provided very limited awareness during the activities in physical spaces.** This limitation prevented the pre-service teacher, for instance, to be aware of the whereabouts of the different students or groups, or what artifacts were being accessed (e.g., the pre-service teacher said in the interview, when asked about the awareness in physical spaces, that "in the physical spaces I think it [GLUEPS-AR] doesn't provide so many possibilities, because you have everything set up, [...]. Once started, in the physical spaces it is very difficult to follow them [students]" [Int 1]). This lack of awareness may be a limitation for the assessment in cases where there is only one teacher, and groups of students are distributed over a large area.

75. Roles

This aspect emphasizes the roles that teachers and other actors take in the orchestration. In the evaluation we gathered evidences pointing out that **GLUEPS-AR provided students with a certain degree of flexibility to self-regulate their learning artifacts, allowing the pre-service teacher to share the management load with**

TABLE 4. LIMITATIONS FOUND IN THE EVALUATION PROCESS

Topic	Limitations	Supporting data
Adaptation	Difficult use of GLUEPS-AR's user interface in mobile devices	Obs 3, Art 6
Awareness	Limited awareness provided by GLUEPS-AR during the activities in physical spaces	Quest 1, Int 1
Pragmatism	Connection and performance problems in the outdoor uploading of artifacts	Obs 3
Pragmatism	User interface terminology not adequate for participants	Obs 3
Roles	Excessive additional lecture time required for increasing the students' flexibility in the management of learning artifacts	Int 1

them. GLUEPS-AR's support for management load sharing was mainly due to the use of learning buckets (see section 3) (the pre-service teacher answered 4, "Somewhat agree", in a 1-6 scale to the assertion "The systems used allow to transfer part of the management load to the students, e.g., taking decisions about the learning artifacts or performing operations over the artifacts, such as create or modify them" [Quest 1]; also, in the interview he specified that "I shared with them part of the load, but in this case I have not shared much. [...] I created the bucket with five Google Docs and they just had to open and fill them [...]. The pictures were taken by them [...] I just explained how to handle the bucket, and they named and uploaded the pictures" [Int 1]; the students' notebooks also illustrate this self-regulation: "We were the first group that finished, so while the rest were completing their tasks, we uploaded the pictures to the [wiki] web" [Art 5]). By using buckets, GLUEPS-AR allowed the teacher to give responsibility to students, and allowed the students to take their own decisions about artifacts. This seemed to favor student engagement and motivation (e.g., the pre-service teacher answered 4, "Somewhat agree", in a 1-6 scale to the assertion "I think that the system allows to give more responsibility to students, allowing them to take decisions about artifacts" [Quest 1]; in the interview he explained "[...] enabling them to create a [orientteering] route is not only useful for putting into practice the theoretical knowledge, but also is motivating for them. Not just to give them existing maps, but also enable them to create the maps. [...] The fact of giving them the freedom of being responsible for the success of the activity is motivating for them. And it is also interesting because the entire group gets involved" [Int 1]; in addition, it was observed that "Group 2 is sharing out the writing of the questions and their inclusion in the web by means of the bucket. They are passing the laptops from one student to another around the table. They seem to be self-regulating well" [Obs 3 - Session 4]; also, one of the observers asked the children about this: "To confirm whether the children understand what they are doing, I ask them. All of them answer correctly that they are generating the questions that the other group will have to solve" [Obs 3 - Session 4]). We also found that **due to time restrictions, the pre-service teacher limited the flexibility offered to the students** (e.g., he created the Google Drive documents and positioned them in AR markers, for the last activity in the park, instead of asking the students to do it): "It

AUTHOR ET AL.: TITLE

11

would have been possible to give them more [freedom], but I didn't do it because of their age and the additional lecture time it would have supposed" [Int 1].

T6. Pragmatism

The pragmatism orchestration aspect highlights the importance of keeping in mind the constraints of authentic educational settings. Regarding this aspect, the evaluation showed that **GLUEPS-AR complied well with the constraints of the pre-service teacher, the institution, and the educational contexts involved**. The pre-service teacher, a non-ICT-expert, reported that GLUEPS-AR is easy to use and he would use it again in the future, although it has an initial learning curve (e.g., he answered 5, "Agree", in a 1-6 scale to the assertion "I think that the system is easy to use for non-ICT-expert teachers" and answered 6, "Strongly agree", to the assertion "I would use the systems again in my practice" [Quest 1]; in the interview, he answered "The creation of artifacts and all that is very easy when you learn how to do it. [...] Maybe the first activity or the first session was difficult, but after that, the rest were very easy" [Int 1]). He also acknowledged that GLUEPS-AR does not restrict the range of applicability to a single type of across-spaces learning situation, ULE, social level (e.g., individual or group) or pedagogical approach (e.g., the pre-service teacher answered 5, "Agree", or 6, "Strongly agree", in a 1-6 scale the questions regarding the range of applicability of the system [Quest 1]). This range of applicability allowed him to design a learning situation compliant with the official curriculum, the institution educational program, and the technologies and spaces he wanted to use.

During the study we detected also **connectivity and performance problems in the functionality related to the outdoor uploading of artifacts** (in uploading pictures to Picasa). Although they did not affect the enactment of the activities negatively, it is a limitation that could be detrimental to other contexts or learning situations. Another limitation was **the terminology used by the system user interface, which was sometimes not familiar for the participants**. An example is the term "artifact" (e.g., "a child is joking with the word artifact" [Obs 3 - Session 5]). This limitation points to the need of adapting the tools and their user interfaces better to the educational contexts they are meant for.

T7. Alignment

Another orchestration aspect is how to align (or coordinate) the different elements to be orchestrated in order to achieve the learning goals. The analyzed data evidences that **GLUEPS-AR enabled the creation of a ULE combining the different physical and virtual spaces, helping to achieve the learning objectives and the engagement of the students**. GLUEPS-AR helped create a continuous learning experience in the multiple activities carried out in different spaces (e.g., the pre-service teacher answered 6, "Strongly agree", in a 1-6 scale to the assertion "The system allows a continuity between the activities performed in different physical and virtual spaces" [Quest 1]; he also said in the interview "What was created in web spac-

es passed to the physical ones, and everything created in the physical space, like the pictures, could go directly to the web space. [...] the transition between classroom and outdoor was... everything complemented very well, and I think that the activity was like a whole, and it followed an order" [Int 1]). In addition, both, the pre-service and the in-service teachers acknowledged that the engagement of the students was favored by the technology and the ULE [Quest 1, Int 1, Int 2] (e.g., the in-service teacher recognized that "at the beginning it seemed that those things were not going to be appealing to the children: the orienteering, which was new to them, [...]. But with the technology they liked it much more" [Int 2]), which was also noticed in the observations and the students' notebooks (e.g., it is illustrated with some of the students' comments: "These have been the best sessions of physical education of the world [...]. It has been very funny and very cool", "We had a very good time conceiving clues and difficult challenges [...]. Above all and first of all, it was great. It was very funny [...]. The class: The best of the year" [Art 5]; also, from observations: "I ask a girl from group 3: What is the thing you liked or attracted your attention more in the session? She answers: to use the tablet for orienteering" [Obs 3 - Session 2]; "The 3G connection of the tablets has not failed and so far the activity is being developed without a hitch. Students seem to be very motivated and they are running from one marker to another" [Obs 3 - Session 3]). Also, both the pre-service and the in-service teacher reported that GLUEPS-AR and the learning situation helped achieve the learning objectives (e.g., the pre-service teacher answered 5, "Agree", or 6, "Strongly agree", in a 1-6 scale to assertions related with the achievement of the objectives and if GLUEPS-AR and the learning situation facilitated it [Quest 1]; in the interview, asked about the achievement of the learning objectives, the in-service teacher answered "Yes [the learning objectives were achieved]. I think that [they were achieved] more than enough" [Int 2]).

T8. Theories

Finally, this aspect deals with the models and theories regarding how orchestration should be performed. Beyond theoretical considerations or measurements of the orchestration itself, we focus on exploring whether the teachers were able to use the pedagogical and organizational approaches they wanted to use or not, i.e., whether the orchestration technology altered the way they would orchestrate similar learning situations. Evaluating this aspect we can detect, for example, if a technology helps a teacher in all the rest of aspects, but it forces him to change his intended way of working, which might lead to the teacher not adopting the technology in his practice. In this sense, evidence shows that **GLUEPS-AR allowed the pre-service teacher to use the pedagogical and organizational approaches he wanted to use** (he answered 6, "Strongly agree", in a 1-6 scale to the assertion "The systems allowed me to put into practice the pedagogical approaches that I wanted to use", and he answered 2, "Disagree", to the assertion "The system forced me to organize student work in a different way than I'm used to" [Quest 1]). However, since the pre-service teacher was not very experienced in teaching, it would be interesting

to explore this aspect with more veteran teachers, who may have more rigid organizational and pedagogical beliefs.

5 DISCUSSION, CONCLUSIONS AND FUTURE WORK

Orienteate! is an innovative learning scenario that took place in multiple physical and virtual spaces, involving a wide ecology of technological and social resources. It was created and enacted by a non-ICT-expert pre-service teacher within the official curriculum and classroom hours. This scenario poses several orchestration challenges, that we structured using the '5+3' orchestration framework, including: the preparation of activities to be implemented with multiple technologies in multiple spaces (*design*), the need to modify the learning design and the accessibility to its artifacts from different spaces (*adaptation*), the sharing of the orchestration load with students (*roles*), or the coordination of resources in different spaces toward scenario's learning goals (*alignment*).

The ubiquitous orchestration technology used in our study, GLUEPS-AR, provided the pre-service teacher with support for the multiple orchestration aspects highlighted in the '5+3' orchestration framework. The system made the across-spaces learning situation feasible for him, and aided him to take advantage of such heterogeneous resources. The pre-service teacher imported into GLUEPS-AR a learning design created with an (external) existing authoring tool, and completed it with spatial information. Also, GLUEPS-AR integrated the wiki-based VLE, the Web 2.0 tools and the AR client, following the instructions of the teacher's learning design, thus fostering a seamless learning experience. The learning buckets embedded in the resulting ULE allowed the students and the teacher to create learning artifacts in different spaces during the enactment, thus sharing the orchestration load. Besides, GLUEPS-AR helped the teacher in other orchestration aspects, such as in the runtime adaptation of the different design elements, as well as the structuring, management, and automatic deployment of the activities, groups and resources. Also, GLUEPS-AR allowed the teacher to choose between multiple existing authoring and enactment tools (e.g., PPC, a wiki, Junaio, Google Drive), facilitating the fulfillment of the theoretical (e.g. promotion of collaborative learning) and pragmatic (e.g. the involvement of non-ICT-expert teachers and students) requirements of the context, teachers and institutions.

The evaluation process presented in this paper illustrates certain lessons, which may be useful for other research efforts in the orchestration of ULEs. One such lesson is that *the design of the learning situation in a ULE was challenging* for the pre-service teacher in its very conceptualization, due to the new possibilities opened by GLUEPS-AR in across-spaces scenarios. We have also seen how *ULEs may be highly prone to unexpected events and technology failures*. In our case, the capability of changing the design and the accessibility of artifacts in different spaces during runtime was critical to avoid breakdowns. Teachers should also be able to make these changes from

the different spaces (e.g., with a mobile device while being outdoors). We have also realized that *technology (e.g., AR) could help teachers avoid the current lack of awareness* when several spaces are used in an activity, or when a space has intrinsic difficulties for the teacher perception. Thus, for example, we could help teachers by providing them with runtime awareness during activities in physical spaces. In addition, the Orienteate! scenario *required a degree of student self-regulation*, to create the orienteering routes and challenges, as well as to upload their pictures. It is worth noticing that the orchestration system enabled such self-regulation, allowing the pre-service teacher to decide the desired degree of self-regulation. Another lesson learned is that *an orchestration system like GLUEPS-AR may transform a set of independent spaces into a unique ULE*, with seamless transitions between the spaces, *enabling the participants to focus on their learning goals instead*, and helping achieve the benefits of a seamless learning across spaces [9]. It is also interesting to highlight the *intrinsic difficulties of evaluating an across-spaces learning situation* like the one described. The Orienteate! learning situation required students to work in groups in different physical and virtual spaces using multiple technologies. Hence, a high number of evaluators were needed to be able to observe the different actors simultaneously (e.g., up to five observers in one of the sessions).

It is important to mention that researchers, occasionally, had to help teachers to solve certain technical problems. Thus, although the researchers had the main role of observers, we had to take part occasionally during enactment (e.g., modifying the resources' accessibility using the GLUEPS-AR user interface from a computer in an outdoor session, or reminding the pre-service teacher about how to perform a certain operation in GLUEPS-AR). These participatory observations helped move the learning situation onwards, avoiding breakdowns when facing an identified limitation or a prototype technological fault, which, once detected, was not relevant for evaluation purposes.

A major concern raised by the evaluation was the long time reported by the pre-service teacher for the conceptualization, implementation, changes and revisions of the learning situation. The evidence gathered points out that this excessive time was due to three main factors. In part it was due to the learning curve of all the new technologies used by the teacher (not only GLUEPS-AR as an orchestration system, but also Junaio, some Web 2.0 tools or wiki functionalities were novel for the teacher). The evaluation showed how well the teacher appropriated GLUEPS-AR, being finally independent in its use. A second factor was that he reflected severely and took critical decisions about the learning design while he was making it explicit and deploying it. This was especially important in this case, since he was not an experienced teacher and making certain decisions proved difficult for him. It is a well-known fact that learning design approaches impose an additional effort in the preparation of activities. However, as exemplified by the teacher's positive comments, this extra time can be acceptable if the teacher perceives that the results are worth it. A last factor, related also to

AUTHOR ET AL.: TITLE

13

the teacher relative lack of experience, was that GLUEPS-AR opened new possibilities, enabling him to connect the activities in different spaces, and to use innovative technologies such as AR (as the teacher mentioned in his final reflections). He had to internalize, embrace these new possibilities, which represented still more aspects to reflect about, before finally materializing the final learning situation. Nevertheless, these results point to a line of further research, focused on the analysis of whether more experienced teachers are able to appropriate these technologies more effortlessly.

We consider that an evaluation like the one performed here, exploring the support provided by a system to the different aspects that can be encompassed under the orchestration metaphor, may be extended to systems not explicitly designed to cover the whole spectrum of orchestration aspects. Hence, any orchestration technology could benefit from an exploration of how it affects the different aspects of orchestration, and especially those that technology is not designed for: a technology focused in supporting the awareness aspect could be detrimental for other aspects, such as management, and this fact could remain unnoticed if the evaluation is centered solely in the awareness support. A holistic evaluation like the one performed can be visualized with the radial diagram showed in Fig. 6. The diagram represents the authors' subjective understanding of the evaluation results, summarizing GLUEPS-AR's orchestration support. It was created by the evaluation team in a panel, after discussing the evaluation results. The figure shows that the orchestration aspects better supported by GLUEPS-AR are *design*, *alignment* and *roles*. On the other hand, the main aspect to improve is the *awareness* (due to the limited awareness during activities in physical spaces), as well as the prototype implementation limitations described in section 4 about GLUEPS-AR's user interface in mobile devices (affecting the *adaptation* aspect), and the outdoor uploading of pictures (affecting *pragmatism*).

There is a tension between trying to cover the complete spectrum of orchestration (all its aspects) through a single feature-filled system, or by means of many simpler, different ones. On the one hand, a single system avoids the problem of learning how to use multiple orchestration technologies. On the other hand, trying to cover all the orchestration aspects in depth with a single proposal may produce extremely complex systems, with possible scala-

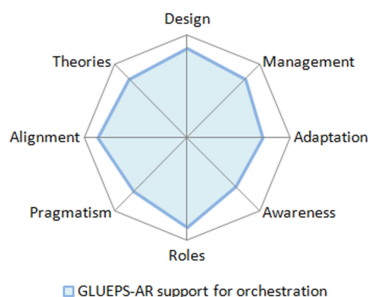

Fig. 6. Radial diagram of GLUEPS-AR's support for orchestration

bility and integration drawbacks. We plan to further explore this tension in the future.

We also plan to conduct, using GLUEPS-AR, other learning situations in different ULEs (e.g., ULEs involving also 3D virtual worlds) and educational contexts. We expect this will allow us to obtain a deeper knowledge about how technology may help teachers in the orchestration of ULEs. Another path for future research work has to do with the quantification of the support provided to different orchestration aspects, which could lead to a more precise radial diagram, similar to the subjective one in Fig. 6. This could aid, for instance, to identify what actions may help or be detrimental in a certain orchestration aspect, enabling comparisons among different orchestration technologies. Also, further research could lead to a classification of possible components of each aspect of the 5+3 orchestration framework, since in some cases we found difficulties in mapping a finding with an orchestration aspect. Moreover, we are already exploring how to provide evaluators with better tools for a more efficient evaluation process in across-spaces learning situations. The present study and the lessons learned from it, together with other past and future research in this emerging field, could lead to a set of design principles for creating orchestration systems for ULEs.

ACKNOWLEDGMENT

This research has been partially funded by the Spanish Project TIN2011-28308-C03-02 and the European Project 531262-LLP-2012-ES-KA3-KA3MP, as well as the Marie Curie Fellowship MIOCTI (FP7-PEOPLE-2012-IEF project no. 327384). The authors appreciate the participation of the school as well as the teachers involved in the evaluation. The authors would like to thank also the rest of the GSIC/EMIC research team (especially Sara García and Vanesa Gallego) for their ideas and support.

REFERENCES

- [1] R. Luckin, "The learner centric ecology of resources: A framework for using technology to scaffold learning," *Computers & Education*, vol. 50, pp. 449-462, 2008.
- [2] M. Sharples, I. A. Sanchez, M. Milrad, and G. Vavoula, "Mobile learning: small devices, big issues," in *Technology Enhanced Learning: Principles and Products*, N. Balacheff, et al., Eds., ed Heidelberg, Germany: Springer, 2009, pp. 233-249.
- [3] L. E. Dyson, A. Litchfield, E. Lawrence, R. Raban, and P. Leijdekkers, "Advancing the m-learning research agenda for active, experiential learning: Four case studies," *Australasian Journal of Educational Technology*, vol. 25, pp. 250-267, 2009.
- [4] B. P. Woolf. (2010, February 2014). A Roadmap for Education Technology. [Report of results on NSF sponsored workshops]. Available: <http://www.cra.org/ccc/files/docs/groe/GROE%20Roadmap%20for%20Education%20Technology%20Final%20Report.pdf>
- [5] L.-H. Wong and C.-K. Looi, "What Seems Do We Remove in Mobile-assisted Seamless Learning? A Critical Review of the Literature," *Computers & Education*, vol. 57, pp. 2364-2381, 2011.
- [6] M. Billinghamurst and H. Kato, "Collaborative Mixed Reality," in *Proceedings of International Symposium on Mixed Reality (ISMIR '99). Mixed Reality--Merging Real and Virtual Worlds*, Yokohama, Japan, 1999, pp. 261-284.

14

IEEE TRANSACTIONS ON LEARNING TECHNOLOGIES, MANUSCRIPT ID

- [7] H. Ishii, M. Kobayashi, and K. Arita, "Iterative Design of Seamless Collaboration Media," *Communications of the ACM*, vol. 37, pp. 83-97, 1994.
- [8] P. Dillenbourg, D. K. Schneider, and P. Synteta, "Virtual Learning Environments," in *Proceedings of the 3rd Hellenic Conference "Information & Communication Technologies in Education"*, Greece, 2002, pp. 3-18.
- [9] T.-W. Chan, J. Roschelle, S. Hsi, K. Kinshuk, M. Sharples, T. Brown, C. Patton, J. Cherniavsky, R. Pea, C. Norris, E. Soloway, N. Balacheff, M. Scardamalia, P. Dillenbourg, C.-K. Looi, M. Milrad, and U. Hoppe, "One-to-one Technology-Enhanced Learning: An opportunity for global research collaboration," *Research and Practice in Technology Enhanced Learning*, vol. 01, pp. 3-29, 2006.
- [10] V. Jones and J. H. Jo, "Ubiquitous learning environment: An adaptive teaching system using ubiquitous technology," in *Beyond the comfort zone: Proceedings of the 21st ASCILITE conference*, Perth, Australia, 2004, pp. 468-474.
- [11] L. Li, Y. Zheng, H. Ogata, and Y. Yano, "A framework of ubiquitous learning environment," in *The Fourth International Conference on Computer and Information Technology (CIT 2004)*, Wuhan, China, 2004, pp. 345-350.
- [12] P. Dillenbourg and P. Jermann, "Technology for classroom orchestration," in *New Science of Learning Cognition Computers and Collaboration in Education*, M. S. Khine and I. M. Saleh, Eds., ed: Springer New York, 2010, pp. 1-20.
- [13] L. P. Prieto, M. H. Dlab, I. Gutiérrez, M. Abdulwahed, and W. Balid, "Orchestrating technology enhanced learning: a literature review and a conceptual framework," *International Journal of Technology Enhanced Learning*, vol. 3, pp. 583-598, 2011.
- [14] D. Spikol and J. Eliasson, "Lessons from Designing Geometry Learning Activities that Combine Mobile and 3D Tools," in *Proceedings of the 6th IEEE International Conference on Wireless, Mobile and Ubiquitous Technologies in Education (WMUTE)*, Kaohsiung, Taiwan, 2010, pp. 137-141.
- [15] R. Martínez-Maldonado, Y. Dimitriadis, A. Clayphan, J. A. Muñoz-Cristóbal, Kay Judy, L. P. Prieto-Santos, and M. J. Rodríguez-Triana, "Integrating orchestration of ubiquitous and pervasive learning environments," in *Proceedings of the 25th Australian Computer-Human Interaction Conference: Augmentation, Application, Innovation, Collaboration (OzCHI '13)*, Adelaide, Australia, 2013, pp. 189-192.
- [16] M. Sharples, "Shared orchestration within and beyond the classroom," *Computers & Education*, vol. 69, pp. 504-506, 2013.
- [17] C.-K. Looi and Y. Toh, "Orchestrating the Flexible Mobile Learning Classroom," in *Increasing Access through Mobile Learning*, M. Ally and A. Tsinakos, Eds., ed: Commonwealth of Learning and Athabasca University, Vancouver, 2014, pp. 161-174.
- [18] J. A. Muñoz-Cristóbal, L. P. Prieto, J. I. Asensio-Pérez, A. Martínez-Monés, I. M. Jorrín-Abellán, and Y. Dimitriadis, "Deploying learning designs across physical and web spaces: Making pervasive learning affordable for teachers," *Pervasive and Mobile Computing*, vol. 14, pp. 31-46, 2014.
- [19] D. Laurillard, "Design Tools for E-learning," presented at the Keynote presentation at the 19th Annual Conference of the Australasian Society for Computers in Learning in Tertiary Education (ASCILITE 2002), Auckland, New Zealand, 2002.
- [20] L. Cohen, L. Manion, and K. Morrison, *Research methods in education*: Routledge, 2007.
- [21] W. J. Orlikowski and J. J. Baroudi, "Studying Information Technology in Organizations: Research Approaches and Assumptions," *Information Systems Research*, vol. 2, pp. 1-28, 1991.
- [22] Y.-M. Huang, Y.-T. Lin, and S.-C. Cheng, "Effectiveness of a Mobile Plant Learning System in a science curriculum in Taiwanese elementary education," *Computers & Education*, vol. 54, pp. 47-58, 2010.
- [23] E. Klopfer and K. Squire, "Environmental Detectives—the development of an augmented reality platform for environmental simulations," *Educational Technology Research and Development*, vol. 56, pp. 203-228, 2008.
- [24] A. M. Kamarainen, S. Metcalf, T. Grotzer, A. Browne, D. Mazza, M. S. Tutwiler, and C. Dede, "EcoMOBILE: Integrating augmented reality and probeware with environmental education field trips," *Computers & Education*, vol. 68, pp. 545-556, 2013.
- [25] K. Facer, R. Joiner, D. Stanton, J. Reid, R. Hull, and D. Kirks, "Savannah: mobile gaming and learning?," *Journal of Computer Assisted Learning*, vol. 20, pp. 399-409, 2004.
- [26] A. Kurti, D. Spikol, and M. Milrad, "Bridging outdoors and indoors educational activities in schools with the support of mobile and positioning technologies," *International Journal of Mobile Learning and Organisation*, vol. 2, pp. 166-186, 2008.
- [27] P. Santos, M. Pérez-Sanagustín, D. Hernández-Leo, and J. Blat, "QuesTInSitu: From tests to routes for assessment in situ activities," *Computers & Education*, vol. 57, pp. 2517-2534, 2011.
- [28] M. Dunleavy, C. Dede, and R. Mitchell, "Affordances and Limitations of Immersive Participatory Augmented Reality Simulations for Teaching and Learning," *Journal of Science Education and Technology*, vol. 18, pp. 7-22, 2009.
- [29] C. Sintoris, A. Stoica, I. Papadimitriou, N. Yiannoutsou, V. Komis, and N. Avouris, "MuseumScrabble: Design of a Mobile Game for Children's Interaction with a Digitally Augmented Cultural Space," *International Journal of Mobile Human Computer Interaction (IJMHCI)*, vol. 2, pp. 53-71, 2012.
- [30] I. Gutiérrez Rojas, R. M. Crespo García, and C. Delgado Kloos, "Enhancing Orchestration of Lab Sessions by Means of Awareness Mechanisms," in *Proceedings of the 7th European Conference on Technology Enhanced Learning*, Saarbrücken, Germany, 2012, pp. 113-125.
- [31] S. Sotiriou, S. Anastopoulou, J. Knight, D. Williams, A. Theo, M. Milrad, A. Maier, S. Rosenfled, and K. Hoeksema, "The CONNECT Project: bridging science education activities at schools and science centers with the support of advanced technologies," in *Proceedings of The First European Conference on Technology Enhanced Learning*, Crete, Greece, 2006.
- [32] M. Tissenbaum, M. Lui, and J. D. Slotta, "Co-Designing Collaborative Smart Classroom Curriculum for Secondary School Science," *Journal of Universal Computer Science*, vol. 18, pp. 327-352, 2012.
- [33] D. Hernández-Leo, R. Nieves, E. Arroyo, A. Rosales, J. Melero, and J. Blat, "SOS: Orchestrating Collaborative Activities across Digital and Physical Spaces Using Wearable Signaling Devices," *Journal of Universal Computer Science*, vol. 18, pp. 2165-2186, 2012.
- [34] S. Ternier, R. Klemke, M. Kalz, P. van Ulzen, and M. Specht, "ARLearn: augmented reality meets augmented virtuality," *Journal of Universal Computer Science*, vol. 18, pp. 2143-2164, 2012.
- [35] M. B. Ibáñez, D. Maroto, J. J. García Rueda, D. Leony, and C. Delgado Kloos, "Architecture for Collaborative Learning Activities in Hybrid Learning Environments," *Journal of Universal Computer Science*, vol. 18, pp. 2187-2202, 2012.
- [36] G. Robles, J. M. Gonzales-Barahona, and J. Fernandez-Gonzales, "Implementing Gymkhanas with Android smartphones: A multimedia m-learning game," in *Global Engineering Education Conference (EDUCON)*, Amman, Jordan, 2011, pp. 960-968.
- [37] H. Sollervall, N. Otero, M. Milrad, D. Johansson, and B. Vogel, "Outdoor Activities for the Learning of Mathematics: Designing with Mobile Technologies for Transitions across Learning Contexts," in *IEEE Seventh International Conference on Wireless, Mobile and Ubiquitous Technology in Education (WMUTE)*, Takamatsu, Kagawa, Japan, 2012, pp. 33-40.
- [38] M. Pérez-Sanagustín, G. Ramirez-Gonzalez, D. Hernández-Leo, M. Muñoz-Organero, P. Santos, J. Blat, and C. Delgado Kloos, "Discovering the campus together: A mobile and computer-based learning experience," *Journal of Network and Computer Applications*, vol. 35, pp. 167-188, 2011.
- [39] P. Dillenbourg, S. Järvelä, and F. Fischer, "The Evolution of Research on Computer-Supported Collaborative Learning," in *Technology-Enhanced Learning*, N. Balacheff, et al., Eds., ed: Springer Netherlands, 2009, pp. 3-19.
- [40] N. Balacheff, R. Bottino, F. Fischer, L. Hofmann, M. Joubert, B. Kieslinger, S. Lindstaedt, S. Manca, M. Ney, F. Pozzi, R. Sutherland, K. Verbert, S. Timmis, F. Wild, P. Scott, and M.

AUTHOR ET AL.: TITLE

15

- Specht, "D1.1 The STELLAR vision and strategy statement," STELLAR, Final report 1.0, 2009.
- [41] J. Roschelle, Y. Dimitriadis, and U. Hoppe, "Classroom orchestration: Synthesis," *Computers & Education*, vol. 69, pp. 523-526, 2013.
- [42] P. Dillenbourg, "Design for classroom orchestration," *Computers & Education*, vol. 69, pp. 485-492, 2013.
- [43] R. Koper, "An Introduction to Learning Design," in *Learning Design. A Handbook on Modelling and Delivering Networked Education and Training*, R. Koper and C. Tattersall, Eds., ed: Springer, 2005, pp. 3-20.
- [44] I. Kollar and F. Fischer, "Orchestration is nothing without conducting – But arranging ties the two together!: A response to Dillenbourg (2011)," *Computers & Education*, vol. 69, pp. 507-509, 2013.
- [45] P. Tchounikine, "Clarifying design for orchestration: Orchestration and orchestrable technology, scripting and conducting," *Computers & Education*, vol. 69, pp. 500-503, 2013.
- [46] J. A. Muñoz-Cristóbal, L. P. Prieto-Santos, J. I. Asensio-Pérez, I. M. Jorrín-Abellán, A. Martínez-Monés, and Y. Dimitriadis, "Sharing the Burden: Introducing Student-Centered Orchestration in Across-Spaces Learning Situations," in *Proceedings of the 8th European Conference on Technology Enhanced Learning (EC-TEL)*, Paphos, Cyprus, 2013, pp. 621-622.
- [47] J. Niramitranon, M. Sharples, C. Greenhalgh, and C.-P. Lin, "Orchestrating Learning in a One-to-One Technology Classroom," in *6th IEEE International Conference on Wireless, Mobile and Ubiquitous Technologies in Education (WMUTE)*, Kaohsiung, Taiwan, 2010, pp. 96-103.
- [48] L. P. Prieto, "Supporting orchestration of blended CSCL scenarios in Distributed Learning Environments," PhD Thesis, University of Valladolid, Spain, 2012.
- [49] L. de-la Fuente-Valentín, M. Pérez-Sanagustín, P. Santos, D. Henández-Leo, A. Pardo, J. Blat, and C. Delgado-Kloos, "System orchestration support for a flow of blended collaborative activities," in *2nd International Conference on Intelligent Networking and Collaborative Systems (INCOS)*, Thessaloniki, Greece, 2010, pp. 415-420.
- [50] L. P. Prieto, J. I. Asensio-Pérez, J. A. Muñoz-Cristóbal, I. M. Jorrín-Abellán, Y. Dimitriadis, and E. Gómez-Sánchez, "Supporting orchestration of CSCL scenarios in web-based Distributed Learning Environments," *Computers & Education*, vol. 73, pp. 9-25, 2014.
- [51] M. Sharples and S. Anastopoulou, "Designing orchestration for inquiry learning," in *Orchestrating inquiry learning*, K. Littleton, et al., Eds., ed: Routledge, 2012, pp. 69-85.
- [52] I. M. Jorrín-Abellán and R. E. Stake, "Does Ubiquitous Learning Call for Ubiquitous Forms of Formal Evaluation? An Evaluand Oriented Responsive Evaluation Model," *Ubiquitous Learning: An International Journal*, vol. 1, pp. 71-82, 2009.
- [53] R. E. Stake, *Standards-Based and Responsive Evaluation*: SAGE Publications Inc., 2004.
- [54] E. Guba, "Criteria for assessing the trustworthiness of naturalistic inquiries," *Educational Communication and Technology Journal*, vol. 29, pp. 75-91, 1981.
- [55] M. B. Miles and A. M. Huberman, *Qualitative Data Analysis. An Expanded Sourcebook*: SAGE Publications Inc., 1994.
- [56] D. Laurillard, P. Charlton, B. Craft, D. Dimakopoulos, D. Ljubojevic, G. Magoulas, E. Masterman, R. Pujadas, E. A. Whitley, and K. Whittlestone, "A constructionist learning environment for teachers to model learning designs," *Journal of Computer Assisted Learning*, vol. 29, pp. 15-30, 2013.



Juan A. Muñoz-Cristóbal received the B.S. degree in telecommunications engineering and the MSc degree in ICT research from the University of Valladolid, Spain, in 1998 and 2010 respectively, and the M.Sc. degree in Free Software from the Open University of Catalonia, Spain, in 2010. After 10 years working as engineer in telecommunication service providers, he joined the GSIC-EMIC

research group at the University of Valladolid, where he is carrying out a Ph.D. Thesis in Technology Enhanced Learning.



scenarios, with special attention to new ways of evaluating these particular settings.



Juan I. Asensio-Pérez received the M.Sc. and Ph.D. degrees in telecommunications engineering from the University of Valladolid, Spain, in 1995 and 2000, respectively. He is currently an associate professor of telematics engineering at the University of Valladolid. His research interests within the field of Technology-Enhanced Learning include: Computer-Supported Collaborative Learning (CSCL) scripting, the integration of external tools in Virtual Learning Environments, the technological support for the orchestration of CSCL situations, the semantic annotation of learning tools in the Web of Data, and the application of Augmented Reality technologies for the support of CSCL situations across multiple virtual and physical spaces.



Alejandra Martínez-Monés, PhD, is associate professor of computer science at the University of Valladolid. Her research interests in the field of Technology-Enhanced Learning relate to how to use computers to support teachers and students in the application and evaluation of innovative teaching and learning strategies, especially CSCL situations. Her research contributions include the use of Social Network Analysis to support the evaluation of CSCL environments; the integration of scripting and monitoring strategies to enhance classroom orchestration, the use of augmented reality to support seamless integration of learning spaces; and the application of mixed methods to evaluate CSCL and other complex learning situations.

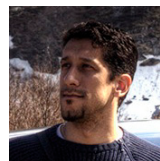

Luis P. Prieto received the PhD degree in ICT from the University of Valladolid in 2012. Before receiving his PhD degree, he worked as a research and development engineer for nine years. He is currently a Marie Curie Postdoctoral Fellow at the École Polytechnique Fédérale de Lausanne, Switzerland. His primary research interests include the orchestration of TEL and CSCL activities, professional development to support technological change, and the application of augmented reality, paper, and tangible interfaces to education.



Yannis A. Dimitriadis received the BS degree from the National Technical University of Athens, Greece, in 1981, the MS degree from the University of Virginia, USA, in 1983, and the PhD degree from the University of Valladolid, Spain, in 1992, all in telecommunications engineering. He is currently a full professor of telematics engineering at the University of Valladolid. His research interests include technological support to the orchestration of computer-supported collaborative learning processes. He is a senior member of the IEEE.

Chapter 7

Coming down to Earth: Helping teachers use 3D virtual worlds in across-spaces learning situations

This chapter describes the first part of the third (and last) cycle of the research process (see Figure 7.1). In this third cycle, we explore in depth the extension of the across-spaces learning situations' scope to a new type of space: 3D Virtual Worlds (3DVWs). There has been extensive research regarding the use of "classical" 3DVWs, such as Second Life, in education. However, such virtual worlds have not achieved a high adoption in the teachers' everyday practice. In this chapter, we explore how GLUEPS-AR could integrate other three dimensional environments highly used in education: Virtual Globes (3D representations of the surface of the Earth, such as Google Earth). Thus, this chapter explores the compatibility of the POI model with VGs, and proposes a new GLUEPS-AR architecture to extend the support provided to across-spaces learning situations to VGs. Also, the architecture enables the use of such VGs as 3DVWs (e.g., including avatars). This chapter explores limitations of alternative approaches to some orchestration aspects of across-spaces learning situations that include web, physical and 3DVW spaces: the affordable deployment of teachers learning designs including such spaces, the "flow" of learning artifacts between the different spaces, and the support in the different spaces of multiple existing enactment technologies of the teachers everyday practice. This chapter presents also an evaluation of the GLUEPS-AR support provided to such limitations. The evaluation comprised a feature analysis (a systematic comparison with alternative approaches) and a pilot study. In the pilot study a teacher used GLUEPS-AR to deploy an across-spaces learning situation that involved a wiki-based VLE, a mobile AR app and a VG, as well as artifacts generated with Web 2.0 tools accessed from the different spaces. The learning situation was simulated by the teacher, but it was not enacted in a real class with students. Figure 7.2 identifies the contributions and evaluation works covered by the chapter in the general thesis diagram. Additional technical details of GLUEPS-AR are included in Appendix B. Also, a general template of the questionnaires employed in the chapter can be found in Appendix C.

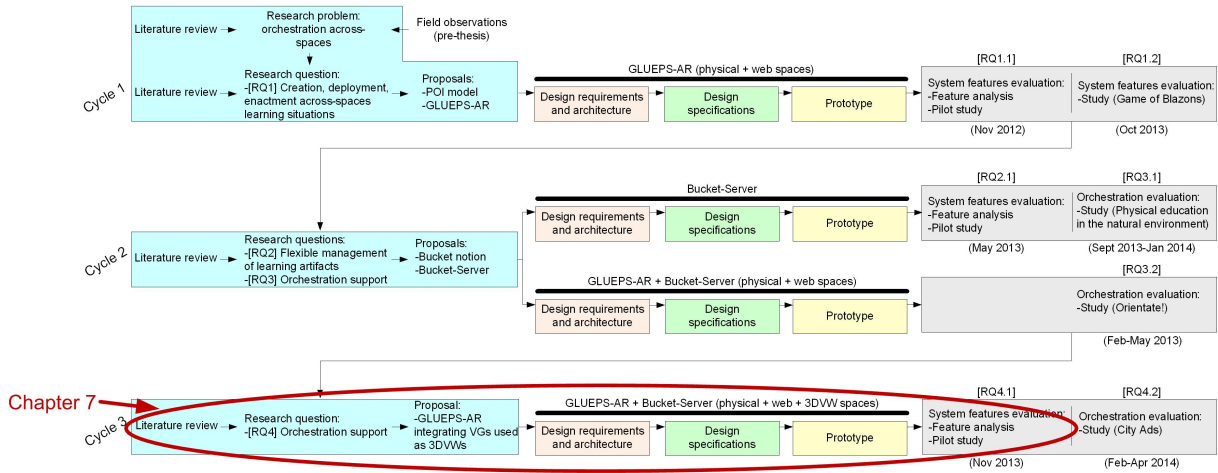

Figure 7.1: Part of the research process covered by Chapter 7.

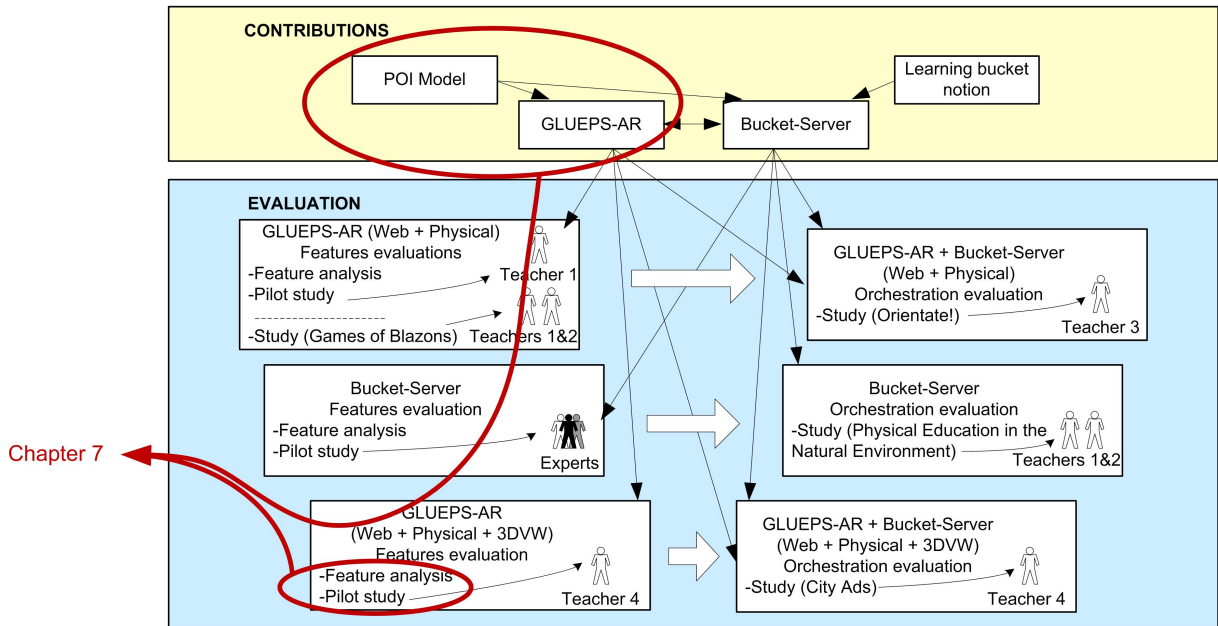

Figure 7.2: Contributions and evaluation works covered by Chapter 7.

The content of this chapter was published in the following journal article:

Muñoz-Cristóbal, J. A., Prieto, L. P., Asensio-Pérez, J. I., Martínez-Monés, A., Jorrín-Abellán, I. M., & Dimitriadis, Y. (2015). Coming Down to Earth: Helping Teachers Use 3D Virtual Worlds in Across-Spaces Learning Situations. *Educational Technology & Society*, 18 (1), 13–26.

Muñoz-Cristóbal, J. A., Prieto, L. P., Asensio-Pérez, J. I., Martínez-Monés, A., Jorrín-Abellán, I. M., & Dimitriadis, Y. (2015). Coming Down to Earth: Helping Teachers Use 3D Virtual Worlds in Across-Spaces Learning Situations. *Educational Technology & Society*, 18 (1), 13–26.

Coming Down to Earth: Helping Teachers Use 3D Virtual Worlds in Across-Spaces Learning Situations

Juan A. Muñoz-Cristóbal^{1*}, Luis P. Prieto², Juan I. Asensio-Pérez¹, Alejandra Martínez-Monés³, Iván M. Jorrín-Abellán⁴ and Yannis Dimitriadis¹

¹School of Telecommunications Engineering, Universidad de Valladolid, Paseo de Belén 15, 47011 Valladolid, Spain // ²CHILI Lab, EPFL, Rolex Learning Center, Station 20, CH-1015 Lausanne, Switzerland // ³School of Computer Engineering, Universidad de Valladolid, Paseo de Belén 15, 47011 Valladolid, Spain // ⁴Department of Secondary and Middle Grades Education, Bagwell College of Education, Kennesaw State University, 1000 Chastain Road MD 0122, Kennesaw Hall, Bldg. #1, 30144-5591 Kennesaw, GA, USA // juanmunoz@gsic.uva.es // luis.prieto@epfl.ch // juaase@tel.uva.es // amartine@infor.uva.es // ijorrina@kennesaw.edu // yannis@tel.uva.es

*Corresponding author

ABSTRACT

Different approaches have explored how to provide seamless learning across multiple ICT-enabled physical and virtual spaces, including three-dimensional virtual worlds (3DVW). However, these approaches present limitations that may reduce their acceptance in authentic educational practice: The difficulties of authoring and sharing teacher-created designs across different 3DVW platforms, or the lack of integration of 3DVWs with existing technologies in the classroom ecosystem (e.g., widespread web-based learning platforms such as Moodle, or mobile augmented reality applications). Focusing on a specific kind of 3DVW (virtual globes, such as Google Earth, used like 3DVWs), we propose a system that enables teachers to deploy across-spaces learning situations, which can be authored with a plethora of existing learning design tools, that involve different common web-based learning platforms, mobile AR applications and multiple kinds of virtual globes. A prototype of the architecture has been developed to evaluate this novel approach. The mixed-methods evaluation performed comprised both a feature analysis and a study where a teacher deployed an authentic across-spaces learning situation including Google Earth used as a 3DVW. Such evaluation shows that the system enables teachers deploy learning situations over different technological ecosystems composed by physical and web spaces, as well as by 3DVWs.

Keywords

3D virtual worlds, Virtual globes, Google Earth, Augmented reality, Across-spaces learning

Introduction

Advances in Information and Communication Technologies (ICT) are bringing about new possibilities for learning, such as those involving different virtual and physical spaces. For example, activities related to botany using a web platform in the classroom can be complemented with activities in a nearby forest (Kurti, Spikol, & Milrad, 2008). Different approaches have explored how to provide a continuous learning experience in these across-spaces learning situations (Kurti et al., 2008; Muñoz-Cristóbal et al., 2014), thus moving toward “seamless learning” (Chan et al., 2006). Mobile devices and Augmented Reality (AR) are among the technical scaffolds that have been explored to connect these physical and virtual spaces (Billinghurst & Duenser, 2012; Muñoz-Cristóbal et al., 2014; Sharples, Sanchez, Milrad, & Vavoula, 2009).

Three-dimensional virtual worlds (3DVW) such as Second Life (<http://secondlife.com>) or Open Wonderland (<http://openwonderland.org>) constitute an additional type of learning space that can be found in currently proposed across-spaces learning scenarios. 3DVWs are three-dimensional virtual environments with similarities to the real world that provide the illusion of being there. 3DVW users are represented using avatars that can interact with other users and objects of the 3DVW in a synchronous or asynchronous fashion (Dickey, 2003; Warburton, 2009). The use of 3DVWs in education has been explored during the last decades, and has shown to provide different learning benefits. More specifically, 3DVWs increase student motivation and also enable the perception of objects from multiple perspectives, the simulation of experiences impossible in the real world, or help knowledge transfer to the real world through the contextualization of learning (Dalgarno & Lee, 2010; Dede, 2009; Dede, Salzman, & Loftin, 1996; Dickey, 2003; Warburton, 2009). Existing examples of across-spaces learning situations involving 3DVW include the combination of activities in Moodle (<https://moodle.org>) and Second Life (Livingstone & Kemp, 2008), or the synchronous interaction among students visiting a replica of a city in Open Wonderland and students physically located in the “real” city, using AR in mobile devices (Ibáñez, Maroto, García Rueda, Leony, & Delgado Kloos, 2012).

However, most of the approaches considering across-spaces learning situations that include 3DVWs show limitations that may contribute to the current lack of acceptance of their proposals in real educational practice (Gregory et al., 2013; Hendaoui, Limayem, & Thompson, 2008; Warburton, 2009). One limitation is the lack of support for teachers to create their own across-spaces learning situations. Also, the available range of technologies for the enactment of the authored scenarios is very limited (e.g., the specific combination of Moodle and Second Life in Livingstone & Kemp, 2008, or Open Wonderland and an ad-hoc mobile client in Ibáñez, et al., 2012). Additionally, existing proposals tend to consider 3DVW-supported activities in a rather isolated way with respect to activities in other 3DVWs, or supported by already existing technologies in the classroom (VLEs, Web 2.0 tools, AR tools).

To overcome these limitations, this paper proposes the architecture and prototype of a system capable of supporting teachers in creating, with a number of existing authoring tools, and deploying their own across-spaces learning situations in a variety of technological ecosystems comprising multiple learning spaces. These ecosystems may be composed of different mainstream VLEs and Web 2.0 tools (web learning space), multiple mobile AR applications (augmented physical learning space), as well as distinct 3DVWs (3DVW learning space). Thus, the system enables activities taking place in multiple physical, 3DVW and web spaces, at the same time or sequentially. Additionally, learning designs can be shared and reused in different technological ecosystems (e.g., those including different 3DVWs).

The system proposed is an extension of the one reported in (Muñoz-Cristóbal et al., 2014), which did not support 3DVWs as learning spaces. Our new proposal integrates Virtual Globes (VGs) such as Google Earth (<http://www.google.com/earth/>), used as a 3DVW. VGs are virtual 3D representations of the surface of the Earth, which are widely known and recurrently used with educational purposes (Chen & Choi, 2010; Lund & Macklin, 2007; Rakshit & Ogneva-Himmelberger, 2008; Schultz, Kerski, & Patterson, 2008; Ternier, Klemke, Kalz, van Ulzen, & Specht, 2012; Wells, Frischer, Ross, & Keller, 2009). Although VGs lack certain presence and interaction features of 3DVW, there exist proposals for their conversion into 3DVWs (see, e.g., Dordevic & Wild, 2012, or <http://youbeq.com>, which include user interaction and avatars in Google Earth). Technical reasons also make it recommendable to integrate VGs in across-spaces learning platforms, since both VGs and physical spaces use the same type of (geographical) coordinates, thus simplifying the flow of learning artifacts and participants among spaces. Furthermore, the growing availability of 3D content for mainstream VGs (see, e.g., Xiao & Furukawa, 2012) opens new opportunities for setting up innovative learning scenarios in VGs, and may promote the adoption of VGs used like 3DVWs by teachers.

The next section describes limitations of current approaches to across-spaces learning situations that include 3DVWs, and distills design requirements that a system should fulfill in order to enable teachers to devise and perform such situations. Then, the paper proposes the architecture and prototype of a system implementing those design requirements. The paper also reports on the evaluation of the proposed system, which involved a feature analysis and a study where a teacher designed and deployed an across-spaces learning situation. Finally, some reflections and conclusions are mentioned.

Limitations of current approaches and design requirements

Several proposals for supporting across-spaces learning situations include activities in 3DVWs. In order to connect *3DVW with web spaces*, some approaches (Dickey, 2003) simply embed a web browser in the 3DVW user interface, triggering different web pages upon the occurrence of certain events in the virtual world. Some approaches can display web pages inside the 3DVW. This is also the case of OPENET4VE (Fernández-Gallego, Lama, Vidal, Sánchez, & Bugarín, 2010) which is able to deploy learning situations in different 3DVWs. Other interesting proposals are Sloodle (<http://www.sloodle.org>; Livingstone & Kemp, 2008), for linking Moodle with Second Life and OpenSim, and the system presented by Pourmirza & Gardner (2013), which links Facebook (<https://www.facebook.com>) with Open Wonderland.

Other approaches study the connection of *3DVWs with physical spaces*. In the Citywide project (Izadi et al., 2002), students explore a physical space (e.g., an archaeological site). At specific locations, students are asked to connect to a 3DVW where they can access objects related to the physical locations. Similarly, Ibáñez, et al. (2012) present a hybrid learning environment where activities may occur both in a physical street using mobile AR, and in a 3DVW

mirroring that same street using desktop computers. Participants in any of the two spaces can see avatars of the other participants and interact with them.

Table 1. Limitations of existing approaches for adoption in educational practice, and design requirements proposed to overcome such limitations

Limitations	Design requirements
Limited range of supported spaces (physical, web, 3DVW).	DR1. Virtual learning resources should be accessible from all three kinds of spaces: physical, web, 3DVW.
Lack of authoring tools usable by teachers.	DR2. Allow teachers to create across-spaces learning situations without requiring high level of technical knowledge.
Activities designed for a specific 3DVW cannot be reused in other virtual worlds.	DR3. Enable teacher designs to be deployed in multiple 3DVWs.
Isolation of 3DVWs from other virtual worlds and technologies in use by teachers.	DR4. Compatibility with multiple platforms/systems within each supported space (physical, web, 3DVW).
	DR5. Users in a 3DVW and users accessing other 3DVWs or platforms/systems on other spaces, have to be aware of the presence of each other.
	DR6. Allow the use of different enactment technologies already in use by teachers and institutions.

Other proposals explore across-spaces learning situations involving *three types of spaces: physical, web and 3DVWs*. DigitalEE (Okada, Tarumi, Yoshimura, & Moriya, 2001) is a system for collaborative environmental education wherein a 3DVW replicates a forest. The participants in the 3DVW can interact with others moving through the real forest, equipped with laptops and GPS. Participants in the physical forest can generate and interact with information (e.g., pictures, videos) which is uploaded to the 3DVW as HTML pages.

However, these proposals are affected by some generic limitations of the 3DVWs (Gregory et al., 2013; Hendaoui et al., 2008; Warburton, 2009), which may prevent the adoption of such approaches in educational practice. In the following paragraphs, we identify limitations that can affect especially across-spaces learning situations involving 3DVWs. From these limitations, we derive a list of design requirements (DR) that may help to overcome such limitations (Table 1).

Typically, across-spaces approaches limit their range of applicability to a *specific combination of physical, 3DVW or web spaces* (see **DR1** in Table 1). Of the aforementioned proposals, only DigitalEE supports learning activities in a 3DVW as well as in physical and web spaces. Thus, e.g., if a teacher using Sloodle wants to include an activity in a physical space, she would need to use another system, probably not integrated so seamlessly with the rest of the technological support.

In addition, there are few cases in which the design of learning scenarios is supported by *authoring tools usable by teachers* without a high level of technical expertise (see **DR2** in Table 1). Such authoring tools have been studied in the field of learning design (Koper, 2005), as a way of explicitly represent pedagogical ideas using computer-interpretable languages, sometimes independently from the targeted enactment platform. OPENET4VE and the system described by Ibáñez, et al. (2012), for example, enable the use of IMS-LD (IMS Global Learning Consortium, 2003) learning designs, thus allowing the use of different authoring tools based in that specification to create activities. In a different way, teachers may design learning situations with Sloodle by using Moodle's user interface.

Another common limitation is that *activities designed for a specific 3DVW cannot be reused in other virtual worlds* (see **DR3** in Table 1). Of the aforementioned approaches, only OPENET4VE and Sloodle enable the use of more than one 3DVW (Second Life and OpenSim), and DigitalEE provides limited support to other VRML-compliant 3DVWs.

Finally, in existing proposals, *virtual worlds normally are isolated, disconnected from other 3DVWs and technologies already in use by teachers and institutions* (e.g., VLEs, Web 2.0 tools or AR applications), thus

hampering the adoption of such proposals in existing educational practice (see *DR4*, *DR5* and *DR6* in Table 1). Among the aforementioned approaches, only Sloodle integrates a widespread VLE (Moodle), and the system presented by Pourmirza & Gardner (2013) integrates Facebook. The rest of approaches integrate mostly ad-hoc, not widely adopted platforms.

Proposal

Following these design requirements, we propose an architecture that enables teachers to define their across-spaces learning situations with different existing authoring tools, and deploy them in complex technological settings which include multiple VLEs, mobile AR clients and VGs used like 3DVWs.

Architecture

Previous work by the authors (Muñoz-Cristóbal et al., 2014) has tackled similar problems of connecting isolated spaces using existing platforms, enabling teachers to deploy their learning situations in different web and AR-enabled physical environments, but not in 3DVWs. Following the design requirements in the previous section, we now extend the previous proposal to consider also VGs used like 3DVWs. The architecture (Figure 1) is based on *adapters* which allow the integration of multiple elements of the same type (i.e., authoring tools, external web tools, VLEs, mobile AR clients and VGs). Once an element is integrated in the architecture, it is connected with the rest of the elements, enabling a multi-to-multi approach comprising already-existing authoring tools (compliant with *DR2*) (e.g., those described in The Learning Design Grid, 2013), VLEs (e.g., Moodle or Blackboard [<http://www.blackboard.com>]), mobile AR clients (e.g., Junaio [<http://www.junaio.com>] or Layar [<https://www.layar.com>]) and VGs (e.g., Google Earth or SkylineGlobe [<http://www.skylinesoft.com>]) (*DR3*, *DR4*, *DR6*). Thus, a teacher could use multiple learning design authoring tools to define her across-spaces activities, and complete them (e.g., with positioning information for the learning artifacts in physical spaces and VGs) in the graphical user interface (*GUI*) of the system (*DR2*).

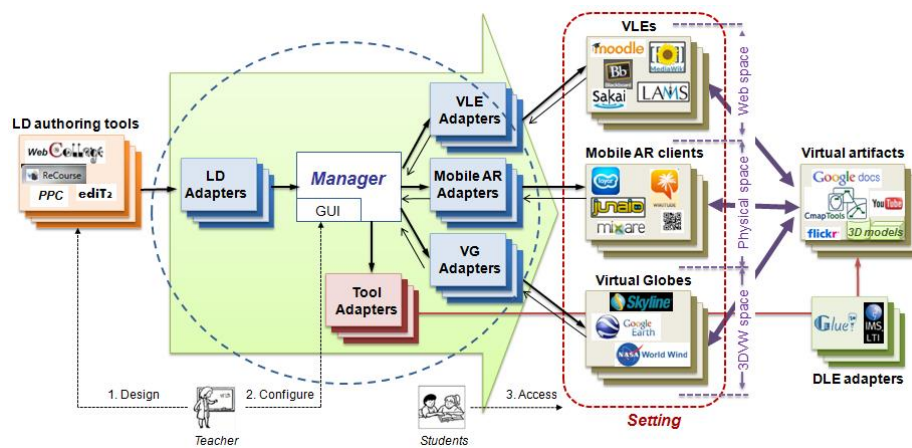

Figure 1. Proposed architecture

The architecture integrates also multiple tools and resources by means of *Tool adapters*. These Tool adapters may integrate, for instance, different Distributed Learning Environment (DLE) (MacNeill & Kraan, 2010) proposals such as Glue! (Alario-Hoyos et al., 2013) or IMS-LTI (IMS Global Learning Consortium, 2012). Thus, a single *DLE adapter* allows the use of multiple tools and resources in a learning scenario (e.g., in the case of Glue!, different Web

2.0 tools, widgets, 3D models or web resources) (**DR4, DR6**). These tools and resources can be accessed from any of the VLEs, mobile AR clients and VGs integrated in the system (**DR1**).

Since VGs are not by themselves 3DVWs (they do not provide avatars or interaction between users), the architecture, by means of the adapters and the *Manager*, enables the use of VGs as if they were 3DVWs, by adding avatars for the users and allowing interaction with any virtual resources and tools supported by the architecture (**DR1, DR5**). Students can interact with resources and tools or create new ones (e.g., opening a Google Docs document located in a VG, or uploading and positioning in the VG a picture taken in the physical space with their mobile device). Also, different communication tools (e.g., a chat) can be included in the teacher’s design and be deployed to this VG-based 3DVW, thus enabling students in a VG to chat with students using mobile AR in a physical location, or with students using a VLE in the classroom. The Manager element acts as a central hub for synchronizing user information in all spaces. Thus, e.g., users in a physical location can see the avatars of users in a VG using AR, and vice-versa (**DR5**).

Integration of multiple Virtual Globes

The integration of an existing VG in the architecture depends on a single requirement: the target VG should have an API or SDK for allowing third parties to position data elements (e.g., learning artifacts or avatars), typically known as “points of interests” (POI). Our proposal uses a POI model for learning artifacts and avatars, which is based on the model described in (Muñoz-Cristóbal et al., 2014). *VG adapters* are in charge of transforming POI representations following this common model, to the different native representations used by each of the VGs.

In order to assess the feasibility of such transformation for existing VGs, we have studied the API or SDK of some of the most widespread VGs (Rakshit & Ogneva-Himmelberger, 2008; Schultz et al., 2008): Nasa World Wind (<http://worldwind.arc.nasa.gov>), Bing Maps (<http://www.bing.com/maps/>), SkylineGlobe, Google Earth, Google Maps/Street View (<https://maps.google.com>) and ArcGIS 3D Analyst (<http://www.esri.com/software/arcgis/extensions/3danalyst>). We consider Google Maps/Street View also a VG because, although it does not support 3D views, its 360° realistic pictures provide an experience very close to that of 3D interfaces. We have also included Bing Maps for the sake of completeness, although its current support for 3D views is quite limited. *Figure 2* shows the POI model used by the proposed system, and the elements of such model that are supported in each VG. The figure also shows how transforming POIs between the proposed system and the different VGs would not imply a significant loss of information. Therefore, all VGs reported in *Figure 2* seem susceptible of being integrated into our proposal (**DR3, DR6**).

POI	Nasa World Wind	Bing maps	Skyline Globe	Google Earth	Google Maps / Street View	ArcGIS 3D Analyst
ID		+				?
POI-type	●	+	●	●		●
icon	●	+	●	+	+	?
name	●	+	●	●	+	+
description	●	+	●	●	●	●
location	+	●	+	●	●	?
position	+	+	+	+	+	+
position-type						
max-distance	●	●	+	●	●	●
rotation	+		+	+		+
translation						+
scale	+		+	+		+
date						

+ Attribute modeled ● The attribute could be modeled through elements not initially defined for that function ? Seems possible to be modeled, but testing is needed

Figure 2. Elements of the POI model employed by the proposed system and their correspondence with the POI model employed by different VGs. (Position-type attribute is not supported, since VGs use only geographical coordinates)

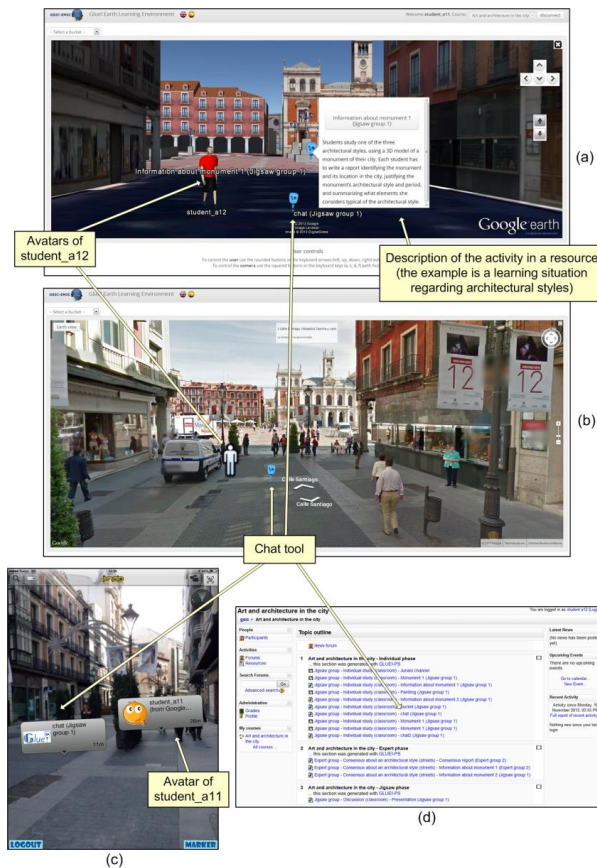

Figure 3. Example of a learning situation illustrating the user interfaces of different learning environments: Google Earth (a) and Google Maps/Street View (b) used like 3DVWs, the Junaio AR client (c) and Moodle (d)

Prototype

We have developed a prototype of the architecture, extending the predecessor architecture’s prototype (Muñoz-Cristóbal et al., 2014), which already integrated three existing authoring tools (as well as other authoring tools compliant with IMS LD level A), two VLEs, four mobile AR clients and the Glue! DLE adapter. Furthermore, we have now integrated two VGs: Google Earth and Google Maps/Street View, used as 3DVWs, modifying the Manager to synchronize user information (and therefore, their avatars) in mobile AR clients and VGs. Figure 3 illustrates the user interfaces of different learning environments in an example learning situation involving Google Earth (a) and Google Maps/Street View (b) used like 3DVWs, the Junaio AR client (c) and Moodle (d). In the figure, a student (student_a11) may access the same activity in virtual downtown Valladolid (Spain) from two VGs: Google Earth (a) and Google Maps/Street View (b). From both VGs, she can see the avatar of another student (student_a12) and some geositioned tools (in this case, a chat and a Google Docs document). Student_a12 is physically in the street in downtown Valladolid, and he is also watching the avatar of student_a11 and the geositioned tools (c), using a mobile device with Junaio AR client. The chat shared by these students is also accessible from within Moodle (d).

Evaluation

An evaluation has been conducted to explore the research question driving our work:
Does the proposed system enable teachers to deploy their across-spaces learning situations including web spaces, AR-enabled physical spaces, and VGs (used like 3DVWs)?

The evaluation consisted of (1) a study wherein a university teacher used the system to deploy an across-spaces learning situation that included Google Earth used like a 3DVW; and (2) a feature analysis, where the evaluation team scored the support of existing approaches and the proposed system to the design requirements defined in Table 1. The next subsections describe the methodological considerations, the evaluation process and its results.

Method

We have followed the Computer Supported Collaborative Learning - Evaluand-oriented Responsive Evaluation Model (CSCL-EREM) (Jorrín-Abellán, Stake, & Martínez-Monés, 2009), using a variety of data gathering techniques in a mixed-method approach (Creswell, Plano Clark, Gutmann, & Hanson, 2003). CSCL-EREM is a framework, focused on the phenomena under evaluation, that provides evaluators with concepts and tools to guide the evaluation of CSCL phenomena (in this case, a technological innovation) in ubiquitous collaborative learning settings. CSCL-EREM is based on the responsive evaluation approach (Stake, 2004) and, therefore, aims at responding to the participants in the evaluation (instead of just describing, measuring or judging them), to get a deep understanding of the setting that may facilitate the adoption of the innovation in practice. This evaluation method is framed within the interpretive research perspective (Orlikowski & Baroudi, 1991), that does not pursue statistically significant results or generalizations, rather aiming a deeper understanding of the concrete phenomena under study (Guba, 1981), in our case, the use of the proposed system by a teacher.

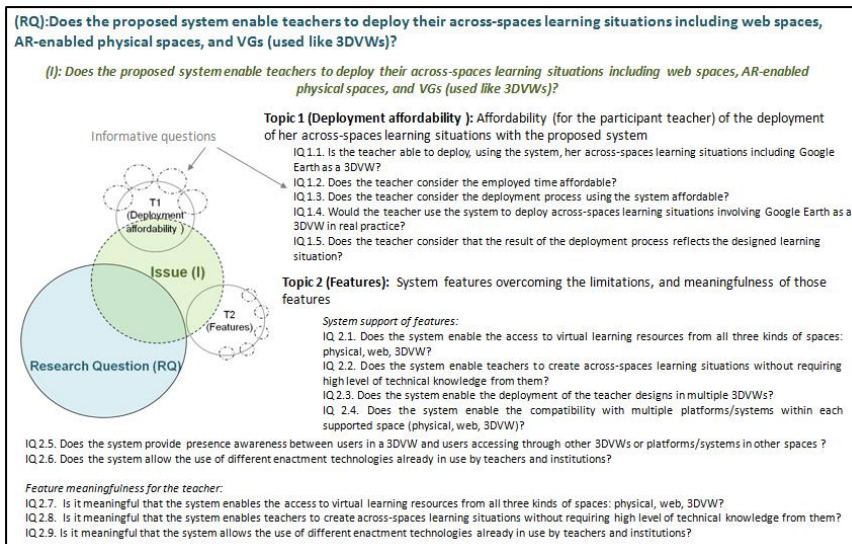

Figure 4. Anticipatory data reduction analysis. (RQ) Research question. (I) Issue. (IQ) Informative question.

To help illuminate our research question, we performed an anticipatory data reduction process (Miles & Huberman, 1994) during the evaluation design (see Figure 4). We defined an issue as the main conceptual organizer of the evaluation process. This issue was split into two more concrete topics, to help us understand different relevant dimensions within the issue: *The deployment affordability for the teacher of her across-spaces learning situations*

(topic 1), and the support offered by the proposed system to overcome weaknesses of existing approaches and the meaningfulness of such features (topic 2). Each topic is investigated through various informative questions, which finally are mapped to data gathering techniques.

As mentioned, the evaluation consisted of a study and a feature analysis. Along the study, a profuse set of data gathering techniques and data sources has been used: teacher-generated artifacts (e.g., emails or learning designs), time recordings, screen recordings (with software that recorded operations in the screen as well as audio and video out of the screen), naturalistic observations (audio, video, pictures and observation notes), web-based questionnaires and interviews (see Figure 5). In parallel with the study, we performed a feature analysis: a systematic comparison of the proposed architecture with alternative approaches, in order to explore if the support of the proposed system to the design requirements defined improves the existing approaches' support. For the feature analysis, we followed the screening method of the DESMET evaluation methodology (Kitchenham, Linkman, & Law, 1997). The screening method is a qualitative feature-based evaluation performed by a single individual or an evaluation group, who not only determines the features to be assessed and their rating scale but also does the assessment. Questionnaires (*Score Sheets* in Figure 5) are used to assess the features, and the scores are compiled in a final report (*Evaluation Profile*).

During our evaluation, triangulation of methods, data sources and evaluators was used, to cross-check data and interpretations as well as to assure the quality and credibility of the research (Guba, 1981). Figure 5 shows the evaluation process, which is divided in different *happenings* (evaluation events), as the CSCL-EREM model recommends, as well as the different data gathering techniques used in each happening, indicating the labels used to refer to them throughout the text.

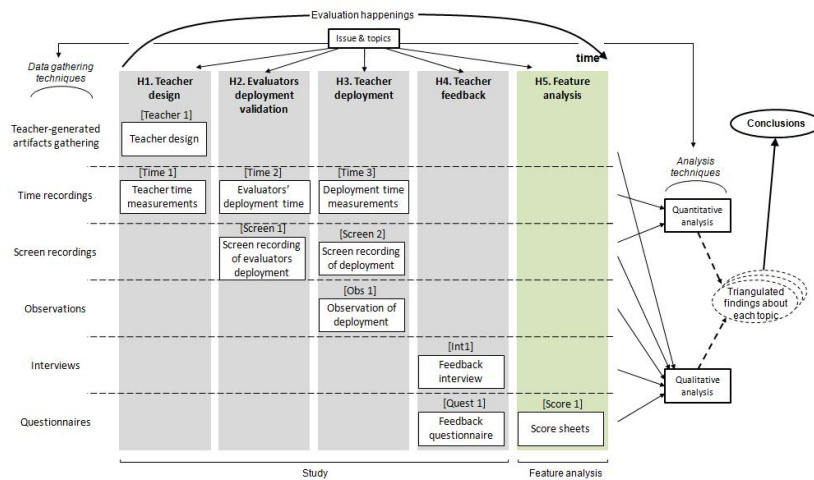

Figure 5. Evaluation happenings and data gathering techniques

Study

Context

The study was performed in the College of Education and Social Work, University of Valladolid (Spain). In the first year (out of four) in the *Degree in Primary Education*, within a mandatory course on ICT for pre-service teachers, four university teachers, usually perform an across-spaces learning situation related to the learning effects of advertising in everyday life. Usually, the situation involves the wiki of the course (used as a VLE), activities in the streets using mobile devices, and activities using Google Maps. Students are instructed to capture pictures of advertisement panels in their way home, writing down their location. Later on, they have to upload the pictures

manually to the wiki and, in groups, they create a map in Google Maps, marking the routes followed by the group's members, and create a marker in the map for each picture, associated to the URL of the picture in the wiki. Finally, students have to elaborate a reflective critique about the advertisements.

Intervention

One of the course teachers, a pedagogue relatively new to teaching (four years of teaching experience), who is familiar with ICT tools, showed interest in enhancing their usual across-spaces learning situation using Google Earth as a 3DVW (instead of the simple 2D Google Map described above). The proposed system may also help improve the connection of activities across the different spaces, automating several manual operations. In a first happening (H1, Figure 5), the teacher conceptualized a learning design without the support of an authoring tool. Then (H2), an ICT-expert from the evaluation team used the WebCollage (Villasclaras-Fernández, Hernández-Leo, Asensio-Pérez, & Dimitriadis, 2013) authoring tool to represent the teacher's learning design, and used the system prototype to deploy the design across the technological enactment platforms (wiki, QR codes and Google Earth). In a subsequent happening (H3), the participant teacher (with the support of an ICT-expert evaluator) performed the authoring of the design with WebCollage and the actual deployment using the system prototype. The teacher also assessed the resulting technological infrastructure, using it in the role of a student. During this deployment session, three observers were present (taking notes, pictures, videos and audio) who, later on, created a multimedia collaborative triangulated observation report, including also an annotated analysis of the complete video of the session. Finally (H4), the teacher gave feedback by means of a web-based questionnaire and a semi-structured interview (to provide further details about the deployment process and her perception of it).

Findings

Figure 6 illustrates the learning situation designed by the teacher, as a variation of the original across-spaces activities usually performed. It is composed of four collaborative activities spanning four hours of face-to-face work and two hours of remote work, performed in the classroom (using a wiki and Google Earth), in the streets (using QR codes and mobile devices for reading them), and online (using Google Earth). In order to use some of the time saved (due to the system's automation of the enactment), a new "counter-ad" activity was included at the end of the design. Also, a simple analysis of advertisement in general was replaced by a detailed analysis of the student-contributed advertisements.

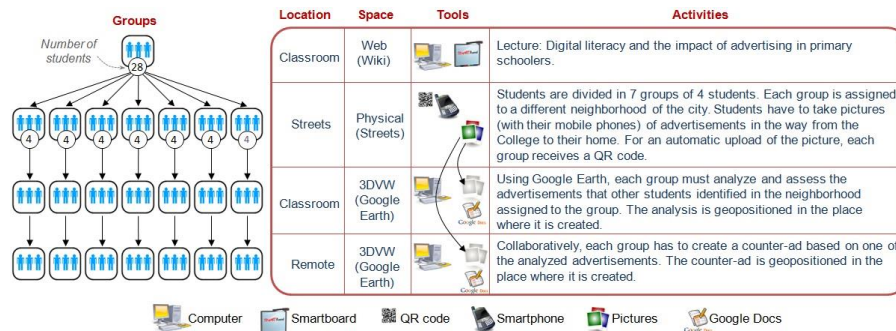

Figure 6. Description of the learning situation created by the teacher

The teacher deployed her learning situation using the prototype (IQ 1.1, see Figure 4), taking 54 minutes to author the design in WebCollage, and 37 minutes to configure that design using the prototype user interface (positioning learning artifacts, reusing tools between activities, etc.) [Time 3, Screen 2, Obs 1] (see Figure 5). As expected, the evaluator spent considerably less time than the teacher in this process, especially regarding WebCollage (7 minutes in WebCollage and 12 in the prototype [Time 2, Screen 1]). This difference was not only due to the evaluator's higher expertise with the systems, but also due to the mechanical nature of copying already-designed activities rather

than reflecting on them (as the teacher did) [Screen 1]. Indeed, even if the conceptual design had already been done on paper, the teacher included last-minute changes in activities during her use of WebCollage (e.g., a questionnaire was replaced by the counter-ad activity in Google Earth [Teacher 1, Screen 2]), and she queried the ICT-expert evaluator about the modeling of some activities using the provided tools (“[...] *The teacher explains a new activity for the last part of the design where she wants students to generate a counter-ad based on one of the previously analyzed ones. ‘How can I make it happen? Which is the best way for my students to upload the image with the counter-ad to Google earth?’ [...] [Obs 1].*”). The teacher considered the total time dedicated to the process was “long” (about 90 minutes) (IQ 1.2) ([when asked to assess the time dedicated in the deployment session:] “*Well, I think it was a long time [...] because in the end it took an hour and a half*” [Int 1]). Nevertheless, she considered such time as acceptable since she felt that the system was intuitive, and subsequent deployments would take less time (“*I think that with another go of practice, it would take me a lot less time*” [Int 1]; “*I think [the time dedicated] is acceptable, since the design can be reused in upcoming years, and in other courses performing minor adaptations [...] anyway, I’m sure that, with practice, the time [it takes] would be greatly reduced, since it is quite intuitive once you know some of the terms that are confusing at the beginning*” [Quest 1]). The teacher also considered the deployment process affordable (IQ 1.3), both in a questionnaire ([to the assertion “I think that the deployment of the scenario with the system has been easy”] she answered “*Agree*”, 5 in a 1-6 scale [Quest 1]) and in the interview [Int 1]. She also showed interest in using the system in her real practice (IQ 1.5). This idea was confirmed during the deployment session (“*I want to use it*” [Screen 1]) as well as in a questionnaire (“*I have the idea of putting [the scenario] in practice the next semester in my courses*” [Quest 1]) and on the interview (“[...] *and probably, if we put this [learning situation] into practice, since I’m convinced that I want to put it into practice, we will change things again [...]*” [Int 1]). After the deployment, she reviewed the resulting learning environment in the wiki and in Google Earth (see Figure 7), and simulated the tasks of a student [Obs 1, Screen 2]. She confirmed that it corresponded well to her initial design (IQ 1.6) [Int 1, Quest 1] (e.g., [to the assertion “do you consider that the result of the deployment process reflects your designed learning situation?”] she answered “*Strongly agree*”, 6 in a 1-6 scale). Finally, she valued as important the three features that she had used (IQ 2.7, IQ 2.8, IQ 2.9), both in the questionnaire (she answered “*Strongly agree*”, maximum in the 1-6 scale, to the three questions asking about those features’ importance [Quest 1]), and in the interview (e.g., “[...] *a teacher has to be trained to be able to design contextualized activities [...], and that implies going beyond things or recipes that already exist. She has to be able to design these materials with the things that she can reach. On the other hand, a teacher also has to reuse things that are known to work, and which are free, [Web] 2.0 tools available to everybody*” [Int 1]).

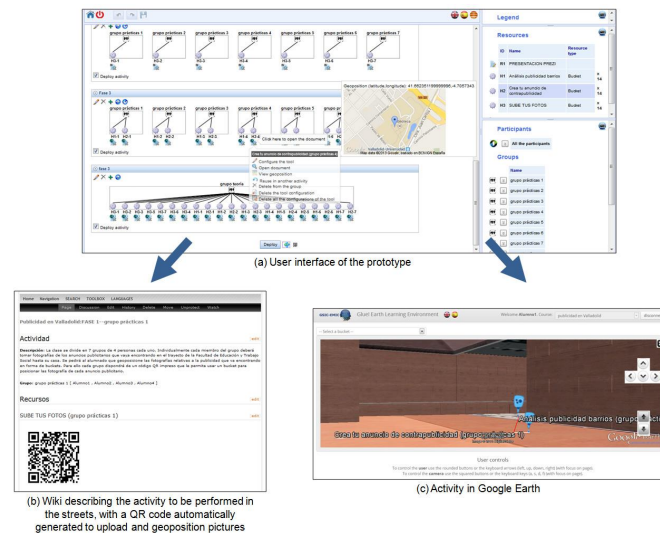

Figure 7. Deployment session: Learning situation configured in the system prototype by the teacher (a), the final result in the wiki (b), and in Google Earth (c)

Feature analysis

Simultaneously to the study, a feature analysis was performed by the evaluation team (H5, see Figure 5). Table 2 shows the Evaluation Profile summarizing the scores obtained (in a 0-5 scale) by the different existing approaches reported in the literature, assessing their support to the design requirements mentioned in Table 1. The publications on each existing approach were studied by the evaluation team. Then, evaluators provided an individual score [Score 1], which was then shared in a two hours panel to discuss conflicting criteria and agree on a final score for each of the approaches.

As Table 2 shows, the proposed system supports all the defined design requirements (IQ 2.1 – IQ 2.6). The feature with the lowest degree of support by the proposed system is DR2, since the authoring tool and user interfaces of the different systems (both the prototype and the authoring tools it supports) could be improved to reduce the learning curve for teachers without high technical knowledge. The existing proposal that was scored nearest second was DigitalEE, since it supports all three spaces (web, physical and 3DVW), and has potential to integrate more than one 3DVW (since it used a standard for the 3D scene’s models).

Table 2. Evaluation profile of the different approaches: (Dickey, 2003) (Di), (Fernández-Gallego et al., 2010) (OP), (Livingstone & Kemp, 2008) (SI), (Pourmirza & Gardner, 2013) (PG), (Izadi et al., 2002) (Cw), (Ibáñez et al., 2012) (Ib), (Okada et al., 2001) (DEE) and the proposed system (PS)

Feature	Conformance score obtained							
	Di	OP	SI	PG	Cw	Ib	DEE	PS
DR1. Accessibility of learning resources from all three kinds of spaces.	0	0	0	0	0	0	5	5
DR2. Allow teachers to create across-spaces learning situations.	1	3	3	3	3	3	3	3
DR3. Enable teacher designs to be deployed in multiple 3DVWs.	0	4	3	0	0	0	3	4
DR4. Compatibility with multiple platforms/systems within each supported space.	0	3	0	0	0	0	0	5
DR5. Presence awareness between users in a 3DVW and users accessing other 3DVWs or platforms/systems on other spaces.	0	0	4	0	4	4	4	4
DR6. Allow the use of different enactment technologies already in use by teachers and institutions.	1	3	3	3	0	1	1	4
Total	2	13	13	6	7	8	16	25
% over the total possible	7	43	43	20	23	27	53	83

Discussion, conclusions and future work

The data gathered in our evaluation highlight that the deployment using the system is affordable for a teacher (topic 1). In addition, the feature analysis shows how the proposed system supports the design requirements defined to ease the adoption of across-spaces learning situations including 3DVWs. To the best of our knowledge, the rest of systems analyzed do not support all such design requirements. Indeed, none of the existing approaches supports all three features that were actually used by the teacher in the design and deployment of her learning situation (topic 2). Thus, the learning scenario devised by the teacher would not be deployable by her without the support of the proposed system (or at least, not in 90 minutes). The findings across these two topics help illuminate our initial research question, providing evidence that *the proposed system enables teachers to deploy their across-spaces learning situations including web spaces, AR-enabled physical spaces, and VGs used like 3DVWs*. We expect that the system and the design requirements proposed here may help to promote the adoption of 3DVWs in across-spaces learning situations, moving 3DVWs closer to everyday practice of teachers and their institutions. We claim that using currently-widespread VGs (e.g., Google Earth) as 3DVWs, and achieving seamless integration with other existing educational technologies (authoring tools, VLEs, Web 2.0 tools, 3D models or AR applications), could significantly help adoption in real practice.

It is worth noting that our feature analysis does not attempt to compare or evaluate across-spaces approaches in general. Rather, it is only valid to compare how different approaches support the specific design requirements we have defined as interesting for teacher adoption. Additionally, the feature analysis was performed using the cited publications as its main base. The evaluation team could not actually test all the approaches or study more detailed documentation. The feature analysis could also be improved by using other methods described by Kitchenham, et al. (1997).

We intend to delve further into this line of research, enacting the learning situation designed by the teacher, as well as exploring other learning situations that make use of the aforementioned set of features, with different teachers, in different educational contexts, and using a variety of existing technologies (e.g., other VLEs, mobile AR clients and VGs). We also plan further research to improve the prototype's usability (DR2), and its current limitations regarding identity and immersion of the users in the 3DVW (Dalgarno & Lee, 2010) (e.g., improving avatar features). Further investigation is also needed to propose a more general architecture, that is able to integrate other types of 3DVWs (e.g., Second Life), or to explore other known limitations of the 3DVWs (e.g., technological, social or psychological) not studied in the present article.

Acknowledgements

This research has been partially funded by the Spanish Project TIN2011-28308-C03-02 and the European Project 531262-LLP-2012-ES-KA3-KA3MP, as well as by a Marie Curie Fellowship within the 7th European Community Framework Programme (MIOCTI, FP7-PEOPLE-2012-IEF project no. 327384). The authors thank especially the teacher involved in the evaluation, as well as Mario Marinero, who developed a first version of the Google Earth adapter in his Degree Thesis and Javier Hoyos, who developed the current version of the Google Earth and Google Maps/Street View adapters. The authors thank also the rest of the GSIC/EMIC research team for their ideas and support.

References

- Alario-Hoyos, C., Bote-Lorenzo, M. L., Gómez-Sánchez, E., Asensio-Pérez, J. I., Vega-Gorgojo, G., & Ruiz-Calleja, A. (2013). GLUE!: An architecture for the integration of external tools in Virtual Learning Environments. *Computers & Education*, 60(1), 122-137.
- Billinghurst, M., & Duenser, A. (2012). Augmented Reality in the classroom. *Computer*, 45(7), 56-63.
- Creswell, J. W., Plano Clark, V. L., Gutmann, M. L., & Hanson, W. E. (2003). Advanced mixed methods research designs. In A. Tashakkori & C. Teddlie (Eds.), *Handbook of mixed methods in social and behavioral research* (pp. 209-240). Thousand Oaks, CA: SAGE Publications, Inc.
- Chan, T.-W., Roschelle, J., Hsi, S., Kinshuk, K., Sharples, M., Brown, ... Hoppe, U. (2006). One-to-one Technology-Enhanced Learning: An opportunity for global research collaboration. *Research and Practice in Technology Enhanced Learning*, 1(1), 3-29.
- Chen, X., & Choi, J. H. (2010). Designing online collaborative location-aware platform for history learning. *Journal of Educational Technology Development and Exchange*, 3(1), 13-26.
- Dalgarno, B., & Lee, M. J. W. (2010). What are the learning affordances of 3-D virtual environments? *British Journal of Educational Technology*, 41(1), 10-32.
- Dede, C. (2009). Immersive interfaces for engagement and learning. *Science*, 323(5910), 66-69.
- Dede, C., Salzman, M., & Loftin, R. B. (1996). The development of a virtual world for learning newtonian mechanics. In P. Brusilovsky, P. Kommers & N. Streitz (Eds.), *Multimedia, Hypermedia, and Virtual Reality Models, Systems, and Applications* (Vol. 1077, pp. 87-106): Springer Berlin Heidelberg.
- Dickey, M. D. (2003). Teaching in 3D: Pedagogical affordances and constraints of 3D Virtual Worlds for synchronous distance learning. *Distance Education*, 24(1), 105-121.
- Dordevic, M. M., & Wild, S. C. (2012). Avatars and multi-student interactions in Google Earth-based virtual field experiences. *Geological Society of America Special Papers*, 492, 315-321.
- Fernández-Gallego, B., Lama, M., Vidal, J. C., Sánchez, E., & Bugarin, A. (2010, July). *OPENET4VE: A platform for the execution of IMS LD units of learning in virtual environments*. Paper presented at the IEEE 10th International Conference on Advanced Learning Technologies (ICALT).
- Gregory, S., Gregory, B., Reiners, T., Fardinpour, A., Hillier, M., Lee, ... Larson, I. (2013, December). *Virtual worlds in Australian and New Zealand higher education: Remembering the past, understanding the present and imagining the future*. Paper presented at the ASCILITE 2013 "Electric Dreams", Macquarie University, Sydney, Australia.

- Guba, E. (1981). Criteria for assessing the trustworthiness of naturalistic inquiries. *Educational Communication and Technology Journal*, 29(2), 75-91.
- Hendaoui, A., Limayem, M., & Thompson, C. W. (2008). 3D social virtual worlds: Research issues and challenges. *Internet Computing, IEEE*, 12(1), 88-92.
- Ibáñez, M. B., Maroto, D., García Rueda, J. J., Leony, D., & Delgado Kloos, C. (2012). Architecture for collaborative learning activities in hybrid learning environments. *Journal of Universal Computer Science*, 18(15), 2187-2202.
- IMS Global Learning Consortium. (2003, January). IMS Learning Design information model. Retrieved November 10, 2013, from http://www.imsglobal.org/learningdesign/ldv1p0/imsl_d_infov1p0.html
- IMS Global Learning Consortium. (2012, March). IMS learning tools interoperability. Retrieved November 21, 2013, from <http://www.imsglobal.org/toolsinteroperability2.cfm>
- Izadi, S., Fraser, M., Benford, S., Flintham, M., Greenhalgh, C., Rodden, T., & Schnädelbach, H. (2002). Citywide: Supporting interactive digital experiences across physical space. *Personal and Ubiquitous Computing*, 6(4), 290-298.
- Jorrín-Abellán, I. M., Stake, R. E., & Martínez-Monés, A. (2009, July). *The needlework in evaluating a CSCL system: The evaluand oriented responsive evaluation model*. Paper presented at the 9th International CSCL Conference, Hong Kong, China.
- Kitchenham, B., Linkman, S., & Law, D. (1997). DESMET: A methodology for evaluating software engineering methods and tools. *Computing Control Engineering Journal*, 8(3), 120-126.
- Koper, R. (2005). An introduction to learning design. In R. Koper & C. Tattersall (Eds.), *Learning Design. A Handbook on Modelling and Delivering Networked Education and Training* (pp. 3-20). Berlin, Germany: Springer.
- Kurti, A., Spikol, D., & Milrad, M. (2008). Bridging outdoors and indoors educational activities in schools with the support of mobile and positioning technologies. *International Journal of Mobile Learning and Organisation*, 2(2), 166-186.
- Livingstone, D., & Kemp, J. (2008). Integrating web-based and 3D learning environments: Second Life meets Moodle. *UPGRADE*, 9(3), 8-14.
- Lund, J., J., & Macklin, S. (2007, June). *ArcGIS and Google Earth: Rules of engagement*. Paper presented at the ESRI Education Users Conference, San Diego, CA, USA.
- MacNeill, S., & Kraan, W. (2010). Distributed Learning Environments. A briefing paper. *JISC Center for Educational Technology & Interoperability Standards*. Retrieved November 21, 2013, from http://wiki.cetis.ac.uk/images/6/6c/Distributed_Learning.pdf
- Miles, M. B., & Huberman, A. M. (1994). *Qualitative data analysis. An expanded sourcebook*. Thousand Oaks, CA: SAGE Publications Inc.
- Muñoz-Cristóbal, J. A., Prieto, L. P., Asensio-Pérez, J. I., Martínez-Monés, A., Jorrín-Abellán, I. M., & Dimitriadis, Y. (2014). Deploying learning designs across physical and web spaces: Making pervasive learning affordable for teachers. *Pervasive and Mobile Computing*, 14, 31-46.
- Okada, M., Tarumi, H., Yoshimura, T., & Moriya, K. (2001). Collaborative environmental education using distributed virtual environment accessible from real and virtual worlds. *SIGAPP Applied Computing Review*, 9(1), 15-21.
- Orlikowski, W. J., & Baroudi, J. J. (1991). Studying information technology in organizations: Research approaches and assumptions. *Information Systems Research*, 2(1), 1-28.
- Pourmirza, S., & Gardner, M. (2013, November). *Integrating a Facebook group with the Open Wonderland environment*. Paper presented at the 3rd European Immersive Education Summit (EiED'13), London, UK.
- Rakshit, R., & Ogneva-Himmelberger, Y. (2008). Application of Virtual Globes in education. *Geography Compass*, 2(6), 1995-2010.
- Schultz, R. B., Kerski, J. J., & Patterson, T. C. (2008). The use of Virtual Globes as a spatial teaching tool with suggestions for metadata standards. *Journal of Geography*, 107(1), 27-34.
- Sharples, M., Sanchez, I. A., Milrad, M., & Vavoula, G. (2009). Mobile learning: Small devices, big issues. In N. Balacheff, S. Ludvigsen, T. de Jong & S. Barnes (Eds.), *Technology Enhanced Learning: Principles and Products* (pp. 233-249). Heidelberg, Germany: Springer.
- Stake, R. E. (2004). *Standards-based and responsive evaluation*. Thousand Oaks, CA: SAGE Publications Inc.

Ternier, S., Klemke, R., Kalz, M., van Ulzen, P., & Specht, M. (2012). ARLearn: Augmented reality meets augmented virtuality. *Journal of Universal Computer Science*, 18(15), 2143-2164.

The Learning Design Grid. (2013). Tools registered at The Learning Design Grid. Retrieved November 21, 2013, from <http://www.ld-grid.org/resources/tools>

Villasclaras-Fernández, E., Hernández-Leo, D., Asensio-Pérez, J. I., & Dimitriadis, Y. (2013). Web Collage: An implementation of support for assessment design in CSCL macro-scripts. *Computers & Education*, 67, 79-97.

Warburton, S. (2009). Second Life in higher education: Assessing the potential for and the barriers to deploying virtual worlds in learning and teaching. *British Journal of Educational Technology*, 40(3), 414-426.

Wells, S., Frischer, B., Ross, D., & Keller, C. (2009, March). *Rome reborn in Google Earth*. Paper presented at the 37th international conference on Computer Applications and Quantitative Methods in Archaeology (CAA), Williamsburg, Virginia, US.

Xiao, J., & Furukawa, Y. (2012, October). *Reconstructing the world's museums*. Paper presented at the Proceedings of the 12th European conference on Computer Vision - Volume Part I, Firenze, Italy.

Chapter 8

City Ads: Embedding virtual worlds and augmented reality in everyday educational practice

This chapter covers the last part of the third cycle of the research process (see Figure 8.1). It continues the works of Chapter 7, evaluating the support provided by GLUEPS-AR integrated with the Bucket-Server to the orchestration of across-spaces learning situations that involve web, physical and 3DVW spaces. The evaluation consisted in a study, in which the same teacher of the Chapter 7 re-designed, deployed and enacted, in a class with 30 students, the across-spaces learning situation initially designed in Chapter 7. The evaluation explored the support provided by GLUEPS-AR and the Bucket-Server to the multiple aspects of orchestration, as well as how the proposals helped the teacher to embed immersive environments such as AR and 3DVWs in her everyday practice. Figure 8.2 indicates the evaluation works covered by the chapter in the general thesis diagram. A general template of the questionnaire used in the study can be found in Appendix C.

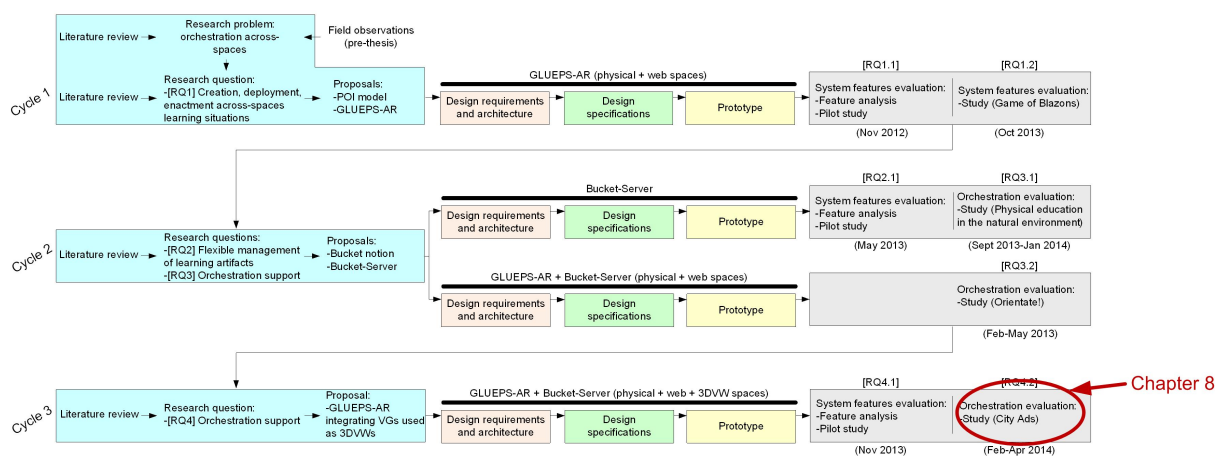

Figure 8.1: Part of the research process covered by Chapter 8.

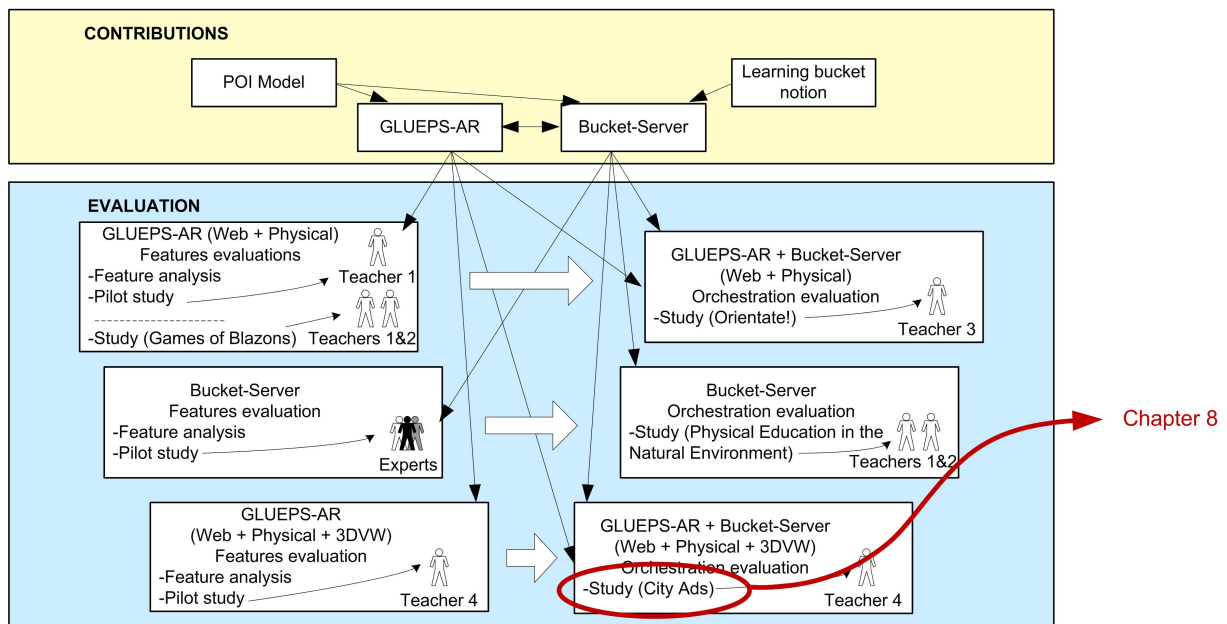

Figure 8.2: Evaluation works covered by Chapter 8.

The content of this chapter was published in the following journal article:

Juan A. Muñoz-Cristóbal, Alejandra Martínez-Monés, Juan I. Asensio-Pérez, Sara L. Villagrà-Sobrino, Javier E. Hoyos-Torio, Yannis Dimitriadis. City Ads: Embedding Virtual Worlds and Augmented Reality in Everyday Educational Practice. *Journal of Universal Computer Science*. Special Issue “Immersive Education: What does the Future Hold?”. Volume 20, Issue 12, pp. 1670-1689. 2014. Accessible from: http://www.jucs.org/jucs_20_12/city_ads_embedding_virtual.

*Journal of Universal Computer Science, vol. 20, no. 12 (2014), 1670-1689
submitted: 31/5/14, accepted: 15/10/14, appeared: 1/11/14 © J.UCS*

City Ads: Embedding Virtual Worlds and Augmented Reality in Everyday Educational Practice

Juan A. Muñoz-Cristóbal

(Universidad de Valladolid, Spain
juanmunoz@gsic.uva.es)

Alejandra Martínez-Monés

(Universidad de Valladolid, Spain
amartine@infor.uva.es)

Juan I. Asensio-Pérez

(Universidad de Valladolid, Spain
juase@tel.uva.es)

Sara L. Villagrà-Sobrino

(Universidad de Valladolid, Spain
sarena@pdg.uva.es)

Javier E. Hoyos-Torío

(Universidad de Valladolid, Spain
javierht@gsic.uva.es)

Yannis Dimitriadis

(Universidad de Valladolid, Spain
yannis@tel.uva.es)

Abstract: The use of immersive environments such as 3D virtual worlds (3DVWs) and augmented reality (AR) in education has been profusely explored during the last decades, showing significant evidence of its benefits for learning. However, the attempts to integrate immersive environments in everyday educational practice are hampered by the difficulties that these environments pose to teachers willing to set them up within the already demanding ecology of technological resources present in the classroom. GLUEPS-AR is a system aimed to help teachers deploy and enact learning designs that make use of web technologies (Virtual Learning Environments and Web 2.0 tools), as well as immersive environments such as virtual globes (e.g. Google Earth) used as 3DVW, and general-purpose mobile AR apps. This paper presents the evaluation of the support provided by GLUEPS-AR for teachers that want to appropriate immersive environments in their everyday practice with an affordable orchestration effort. The evaluation followed an interpretive research perspective, and it was carried out in the context of an authentic learning situation about advertising, conducted at a university undergraduate course for pre-service teachers. The results of the evaluation showed that GLUEPS-AR effectively supported the teacher in seamlessly embedding 3DVWs and AR in her practice.

Keywords: Virtual world, Augmented reality, Immersion, Ubiquitous learning, Seamless learning

Categories: K.3.1, K.3.2, L.3.0, L.3.6, L.7

Munoz-Cristobal J.A., Martinez-Mones A., Asensio-Perez J.I., Villagra-Sobrinio S.L. ... 1671

1 Introduction

3D Virtual Worlds (3DVWs) and Augmented Reality (AR) are immersive environments [Dede 2009] that have been explored extensively by the Technology Enhanced Learning (TEL) research community [Duncan et al. 2012] [Wu et al. 2013] with positive results regarding their learning benefits. Thus, for example, they enable the perception of objects from multiple perspectives, the simulation of experiences difficult to enact in the real world, while they may also enhance both the transfer of knowledge to reality and the engagement of students [Dede 2009] [Duncan et al. 2012] [Billinghurst and Duenser 2012] [Wu et al. 2013].

However, embedding these immersive technologies within everyday educational practice is still a challenge [Dörner et al. 2011] [Gregory et al. 2013]. As a consequence, the proposals that make use of immersive environments tend to take the form of isolated systems, disconnected from other technologies existing in the classroom [Gregory et al. 2013]. Moreover, most of these proposals explore new ad-hoc learning situations, specifically created for the use of immersive environments, instead of incorporating those environments into already existing learning situations (see, e.g., [Facer et al. 2004] [Mennecke et al. 2008] as examples of learning situations created for a specific mobile AR application and a 3DVW respectively). In addition, teachers have to face many difficulties when they try to include immersive environments into the classroom technological ecology. Some of these complications refer to the preparation and deployment of the learning situation itself, its management and adaptation during the enactment, and the coordination of the different technological resources toward the learning goals [Dörner et al. 2011] [Warburton 2009]. These difficulties, also applicable to other non-immersive environments, have been conceptualized by the TEL community under the “orchestration” metaphor [Prieto et al. 2011], i.e., the coordination of learning activities in complex authentic educational settings.

Trying to overcome these problems we have created GLUEPS-AR [see Section 3.3]: a system aimed to help teachers put into practice learning situations that may make use of web-based Virtual Learning Environments (VLEs), as well as of immersive environments such as mobile AR apps and Virtual Globes (VGs) [Rakshit and Ogneva-Himmelberger 2008]. VGs are 3D virtual representations of the surface of the Earth, such as Google Earth¹. GLUEPS-AR adds some characteristics of 3DVWs to these VGs, such as avatars and the possible interaction of users with learning artefacts and other users. Issues related to the deployment of immersive learning experiences with GLUEPS-AR have been previously evaluated in a study wherein a teacher tested the use of the system in a controlled laboratory environment [Muñoz-Cristóbal et al. in press]. However, this study did not include an authentic enactment with real students, in which the orchestration support provided by GLUEPS-AR could be evaluated. Therefore, in this paper we present a new evaluation study, following an interpretive research perspective [Cohen et al. 2007] [Orlikowski and Baroudi 1991], to explore the research question of *how does GLUEPS-AR help teachers appropriate immersive environments such as 3DVWs and mobile AR in their current educational practice and technological ecology of the*

¹ <http://www.google.com/earth/>. Last access September, 2014

1672 Munoz-Cristobal J.A., Martinez-Mones A., Asensio-Perez J.I., Villagra-Sobrino S.L. ...

classroom with an affordable orchestration effort. In the study, a lecturer of an undergraduate course for pre-service teachers included immersive environments (VGs and mobile AR) in a regular learning situation of the course. We explored how GLUEPS-AR helped the lecturer put into practice such learning situation, integrating immersive environments into her everyday practice.

The structure of the paper is the following. [Section 2] describes the aforementioned learning situation, which we consider illustrative of the difficulties for the inclusion of immersive environments in everyday educational practice. [Section 3] reviews different approaches for using immersive environments in education, identifying some of the challenges for the incorporation of immersive technologies into everyday practice. Also, the GLUEPS-AR system is presented as a technology aiming to overcome such challenges. [Section 4] describes the evaluation performed, and finally, some conclusions are outlined.

2 City Ads: A Learning Situation Integrating Immersive Environments into the Regular Ecology of the Classroom

City Ads is an educational scenario conducted in the first year (out of four) of the Degree in Early Childhood Education, at the University of Valladolid, Spain, in spring 2014. It aimed to help students understand the learning effects of advertising in everyday life. The learning goals of the scenario included the fostering of skills for the critical analysis of advertisement, as well as the familiarization with the educational possibilities of Web 2.0 tools, VGs and AR browsers. The City Ads scenario was carried out in a course on ICT in Education with 30 enrolled students, by a regular teacher of the course. The usual wiki-based VLE of the course was employed as a central hub, where students and groups could access the description of the different activities, as well as the learning tools and artefacts to use.

[Fig. 1] describes the City Ads learning situation. It consisted of six activities which were conducted in a Ubiquitous Learning Environment (ULE) [Li et al. 2004] involving different physical and virtual spaces: a classroom, the AR-enabled streets of the town (by means of the Junaio² and Layar³ mobile AR browsers), the students' homes, a wiki, Google Earth and Google Street View. Significantly, immersive environments such as mobile AR (Junaio and Layar) and VGs (Google Earth and Google Street View) used as 3DVWs, were integrated with other non immersive technologies used regularly in the course, like the wiki-site and several Web 2.0 tools (e.g., Google Drive⁴). It is noteworthy that this learning situation had been conducted during the previous years without the use of immersive technologies. In City Ads, the teacher decided to include immersive technologies in order to further enrich the situation and to seamlessly connect the activities in different spaces. Thus, demanding technological enhancements were included, such as the incorporation of mobile AR browsers as well as the replacement of the previous isolated 2D version of Google Maps with 3D VGs integrated with the rest of the environments.

² <http://www.junaio.com>. Last access September, 2014

³ <https://www.layar.com>. Last access September, 2014

⁴ <https://drive.google.com>. Last access September, 2014

Munoz-Cristobal J.A., Martinez-Mones A., Asensio-Perez J.I., Villagra-Sobrinio S.L. ... 1673

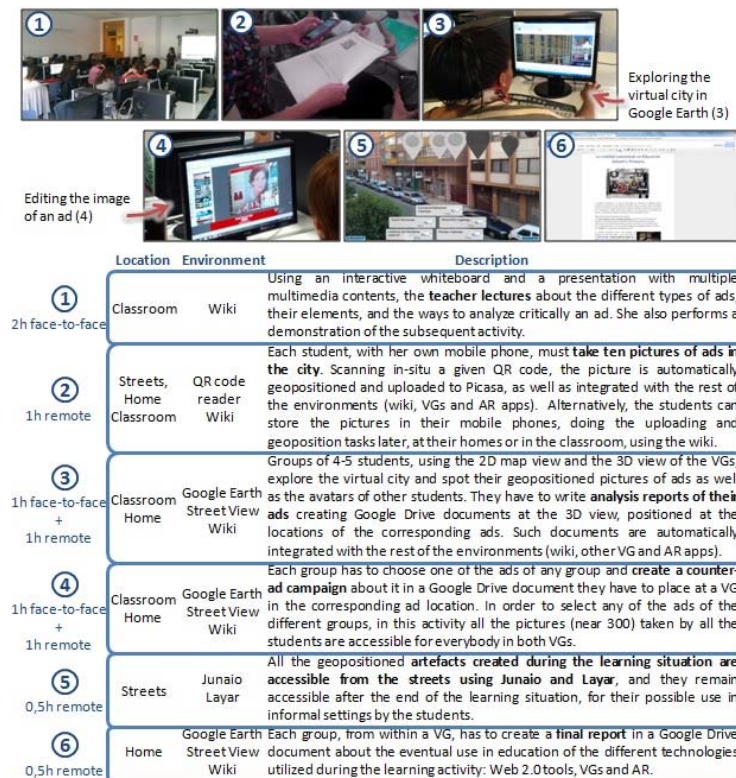

Figure 1: The six activities of the City Ads learning situation

The following section identifies some challenges that different approaches in the literature pose for the teachers' appropriation of immersive environments in their everyday practice like in the case illustrated with the City Ads scenario.

3 Immersive Environments in Education and Challenges for Their Embedding in Everyday Practice

Despite all the research efforts regarding the use of immersive technologies such as 3DVWs and AR in education, as well as the new learning opportunities that this sort of environments may provide, the use of immersive technologies in everyday educational practice is still a problem. This section reviews existing approaches for

1674 *Munoz-Cristobal J.A., Martinez-Mones A., Asensio-Perez J.I., Villagra-Sobrino S.L. ...*

using 3DVWs and AR in education and identifies some challenges posed for the inclusion of such technologies in the teachers' everyday practice.

3.1 Approaches for Using Immersive Environments in Education

Several proposals have explored the use of immersive environments like AR and 3DVWs in education [Duncan et al. 2012] [Wu et al. 2013]. One of these approaches consists in the use of head-mounted displays. That is the case of [Kaufmann and Schmalstieg 2002], who proposed AR and 3D models for mathematics and geometry education; [Vlahakis et al. 2002], who used AR for augmenting archaeological sites; and [Fernández-Panadero and Delgado Kloos 2013], who explored the use of virtual reality (VR) for navigating in a 3DVW with a wheelchair simulator. Also [Billinghurst and Duenser 2012] studied the use of head-mounted displays, enabling both to augment a book with AR and to take part into the virtual scene with VR.

Other authors have used mobile AR apps to conduct learning situations wherein virtual objects enriched or transformed physical environments. [Facer et al. 2004] converted the surroundings of a school in a savannah. [Klopfer et al. 2011] proposed different authoring tools for creating AR games. [Santos et al. 2011] used a web app to create geopositioned questionnaires. [Pérez-Sanagustín et al. 2011] employed mobile devices to provide information about different buildings in a university campus. [Billinghurst and Duenser 2012] proposed a mobile app to enable virtual views of buildings destroyed by an earthquake. [Di Serio et al. 2013] and [Fernández-Panadero and Delgado Kloos 2013] enriched, using AR, paintings and other artefacts. [Kamarainen et al. 2013] used AR and probes for environmental education.

Similarly, a number of research works have explored the use of non-mobile AR (e.g., desktop or whiteboard based) in education. That is the case of [Kerawalla et al. 2006] for teaching science, [Alcañiz et al. 2010], with different educational applications (e.g., for geometry, anatomy or natural sciences), as well as [Spikol and Eliasson 2010], using AR and 3D models for learning geometry. Also [Billinghurst and Duenser 2012] proposed an authoring tool for creating 3D AR scenes.

In addition, several authors have researched the application of 3DVWs in education. Thus, for instance, [Dede et al. 2004] and [Lim et al. 2006] explored the use of ad-hoc 3DVWs in education, and [Dickey 2005] studied a 3DVW based on Active Worlds⁵ in distance learning. Other authors have employed existing 3DVWs, such as [Jarmon et al. 2008] and [Mennecke et al. 2008], who used Second Life⁶ for project-based learning and for an e-commerce course respectively.

Also, there is a growing use of VGs in education [Rakshit and Ogneva-Himmelberger 2008], including their emerging use as 3DVWs, with avatars as well as interaction between users (e.g., using a chat) [Dordevic and Wild 2012].

Some research works have explored the problem that the authoring of learning situations and the execution of sequences of activities when using 3DVWs pose for teachers. Thus, a number of authors have followed a learning design approach [Koper 2005], which suggests the generation of abstract learning designs, represented in languages or models independent of the enactment tools to be used. Thus, such authors propose to enable the deployment and execution of learning designs modelled

⁵ <https://www.activeworlds.com>. Last access September, 2014

⁶ <http://secondlife.com>. Last access September, 2014

Munoz-Cristobal J.A., Martinez-Mones A., Asensio-Perez J.I., Villagra-Sobrino S.L. ... 1675

in one of such languages (IMS-LD⁷) in Open Wonderland⁸ [Maroto et al. 2011], Second Life and OpenSim⁹ [Fernández-Gallego et al. 2010].

In addition, a number of authors have integrated 3DVWs with other widespread technologies, such as VLEs or Web 2.0 tools. [Pourmirza and Gardner 2013] integrated Facebook¹⁰ with Second Life. [Livingstone and Kemp 2008] proposed Sloodle, which integrates Moodle¹¹ with Second Life and OpenSim. Several works have used Sloodle during the last years in multiple educational scenarios (e.g., see [Callaghan et al. 2009] [Schaf et al. 2012]).

Finally, some works have explored the integration of 3DVWs with physical spaces. Some authors connected physical objects with their virtual representation in a 3DVW, enabling interaction with remote or virtual laboratories [Peña-Rios et al. 2013] [Schaf et al. 2012]. In other cases, AR connected physical spaces with 3DVWs [Ibáñez et al. 2012] [Izadi et al. 2002] [Okada et al. 2001], or with VGs [Ternier et al. 2012] and Web 2.0 tools [Chen and Choi 2010] [Zurita et al. 2014].

3.2 Challenges for Embedding Immersive Environments in Everyday Educational Practice

The aforementioned approaches, which explore the use of immersive technologies in education, present several challenges for their utilization in everyday educational practice [Warburton 2009] [Gregory et al. 2013] [Dörner et al. 2011]. We identify below some of these challenges, which are also illustrated by the City Ads scenario (a situation derived from the normal practice of a teacher) [see Tab. 1].

Works studying the use of immersive technologies in authentic educational scenarios use to explore new learning situations that have been created specifically for such technologies. *These situations are not part of the authentic learning situations conducted regularly by the involved teachers and therefore, of their everyday practice* (see challenge #1 in [Tab. 1]). That is the case of most approaches mentioned above, although some of them include immersive technologies in learning situations conducted regularly by the involved teachers [Jarmon et al. 2008] [Santos et al. 2011] [Alcañiz et al. 2010] [Billinghurst and Duenser 2012] [Dickey 2005] [Kerawalla et al. 2006] [Ternier et al. 2012] [Di Serio et al. 2013].

In addition, *approaches using immersive environments are usually isolated, disconnected from the widespread technologies used in everyday educational practices (e.g., VLEs and Web 2.0 tools)* (see challenge #2 in [Tab. 1]), complicating the transitions between different environments. Exceptions to this limitation are approaches exploring the integration of 3DVWs with Moodle [Callaghan et al. 2009] [Livingstone and Kemp 2008] [Schaf et al. 2012] and Facebook [Pourmirza and Gardner 2013], as well as systems proposing the integration of AR, VGs and Web 2.0 tools [Chen and Choi 2010] [Zurita et al. 2014].

Also, most of the existing proposals typically *preclude teachers from using different types of immersive environments (e.g., AR and 3DVWs) and multiple existing*

⁷ <http://www.imsglobal.org/learningdesign/>. Last access September, 2014

⁸ <http://openwonderland.org>. Last access September, 2014

⁹ <http://opensimulator.org>. Last access September, 2014

¹⁰ <https://www.facebook.com>. Last access September, 2014

¹¹ <https://moodle.org>. Last access September, 2014

1676 Munoz-Cristobal J.A., Martinez-Mones A., Asensio-Perez J.I., Villagra-Sobrino S.L. ...

immersive technologies of the same type (e.g., different mobile AR apps) (see challenge #3 in [Tab. 1]). Hence, teachers depend on the constraints of the proposed immersive technology. Many of the approaches described above allow teachers to use different types of immersive environments (e.g., AR and 3DVW [Chen and Choi 2010] [Ibáñez et al. 2012] [Izadi et al. 2002] [Okada et al. 2001] [Ternier et al. 2012] [Zurita et al. 2014]). However, among all these approaches, only the system proposed by [Okada et al. 2001] supports more than one 3DVW and only the framework proposed by [Zurita et al. 2014] could be potentially used with more than one specific VG. It is worth noting that the systems proposed by [Livingstone and Kemp 2008] and [Fernández-Gallego et al. 2010] allow multiple 3DVWs, but on the contrary, their use is limited to that specific type of immersive technology.

Moreover, several approaches propose systems that entail several difficulties for teachers when orchestrating their learning situations (see challenge #4 in [Tab. 1]). This limitation complicates their potential use in the teachers' authentic everyday practice. Some of the proposals mentioned above try to help teachers in some specific orchestration aspects (but not in all aspects encompassed under the orchestration metaphor by the TEL community, see [Prieto et al. 2011]), such as enabling them to create and deploy by themselves their learning designs by means of authoring tools (see e.g., [Billinghurst and Duenser 2012] [Fernández-Gallego et al. 2010] [Kamarainen et al. 2013] [Klopfer et al. 2011] [Livingstone and Kemp 2008] [Maroto et al. 2011] [Santos et al. 2011] [Ternier et al. 2012] [Pérez-Sanagustín et al. 2011]). There are also proposals that include monitoring functionalities to help in the assessment of students (see e.g., [Facer et al. 2004] [Callaghan et al. 2009] [Santos et al. 2011] [Pérez-Sanagustín et al. 2011] [Ternier et al. 2012] [Zurita et al. 2014]), or aim to help teachers in the management of the learning situation (e.g., by means of intelligent non-player-characters [Ibáñez et al. 2012], or automating the creation of tool instances [Livingstone and Kemp 2008] [Pourmirza and Gardner 2013]).

Despite some of the reviewed approaches may help teachers in some of the identified challenges, to the best of our knowledge none of these approaches have dealt with potential solutions for all of them. The following section describes GLUEPS-AR, a system that aims to overcome all these challenges.

Challenges	Examples in the City Ads scenario
1. Including immersive environments in authentic learning situations regularly conducted by teachers	VGs and mobile AR apps have to be included in a learning situation conducted regularly in the course
2. Integrating immersive environments with widespread technologies commonly used by teachers, such as VLEs and Web 2.0 tools	VGs and AR have to be integrated with the wiki-based VLE and the Web 2.0 tools frequently used by the teacher
3. Enabling the use of multiple existing immersive environments of different types	Two VGs and two mobile AR browsers have to be used
4. Helping teachers in the multiple aspects of the orchestration of learning situations that include immersive and non-immersive environments	The learning situation has to be created and enacted by the teacher. It requires the creation and access from different environments of more than 500 artefacts

Table 1: Challenges for the integration of immersive environments in the teacher's everyday practice and examples of these challenges posed by the City Ads scenario

Munoz-Cristobal J.A., Martinez-Mones A., Asensio-Perez J.I., Villagra-Sobrino S.L. ... 1677

3.3 GLUEPS-AR

[Fig. 2] describes GLUEPS-AR [Muñoz-Cristóbal et al. in press], a system that aims to help teachers put into practice their own learning situations in ULEs involving multiple physical and virtual spaces. Such ULEs may be composed of different types of existing immersive and non-immersive environments, such as widespread web VLEs (e.g., Moodle), general-purpose mobile AR apps (e.g., Junaio) and broadly used VGs (e.g., Google Earth). In addition, virtual artefacts (e.g., 3D models, web pages or multiple Web 2.0 tool instances) may be created and accessed from within any of the different environments. The VGs are used as 3DVWs by including avatars and interaction (users may interact with learning artefacts and with other users, e.g., by means of a chat or other collaborative tools).

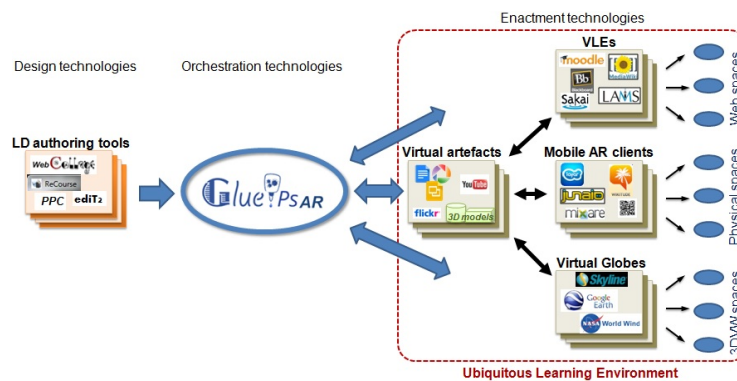

Figure 2: The GLUEPS-AR system: an orchestration technology that integrates immersive and non-immersive learning environments used across multiple physical and virtual spaces

GLUEPS-AR has been designed with an architecture based on adapters that facilitates its extensibility [Muñoz-Cristóbal et al. in press]. Thus, a new technological learning environment (i.e., VLE, VG, AR client) can be easily integrated in the architecture by creating an adapter. Allowing the potential use of several existing technologies and different types of immersive and non-immersive environments may help to overcome the challenges #2 and #3 of [Tab. 1]. Moreover, GLUEPS-AR enables teachers to deploy their own learning situations, which may be created by themselves using multiple learning design authoring tools¹². This feature addresses the challenge #1 of [Tab. 1]. Also, as shown in [Fig. 2], GLUEPS-AR has been conceived as an orchestration technology [Sharples 2013], trying to provide support for multiple orchestration aspects, and therefore, addressing challenge #4 of [Tab. 1].

¹² See a list of learning design authoring tools at <http://www.ld-grid.org/resources/tools>. Last access September, 2014

1678 Muñoz-Cristobal J.A., Martínez-Mones A., Asensio-Perez J.I., Villagra-Sobrino S.L. ...

Thus, in addition to enabling teachers to deploy their designs, GLUEPS-AR provides them with a user interface, wherein they can manage, adapt and monitor the learning situation. GLUEPS-AR automates the creation of Web 2.0 tool instances by means of integration adapters [Alario-Hoyos and Wilson 2010]. GLUEPS-AR also allows a degree of self-regulation for the students in the management of learning artefacts, and therefore, sharing the orchestration load with them [Sharples 2013]. This last feature is achieved by the concept of *learning bucket* [Muñoz-Cristóbal et al. 2013]. A learning bucket is a container of learning artefacts (written reports, drawings, pictures, etc). Teachers may include learning buckets in their learning designs and configure constraints for their use (e.g. number and types of artefacts to be generated). During the enactment, learning buckets may be filled by the students with artefacts that they generate and position in different spaces (e.g., a Google Drive document in a specific geographical location or a picture in an AR marker).

In the following section, we evaluate how GLUEPS-AR helps teachers to embed immersive environments in their everyday practice.

4 Evaluation

We have conducted an evaluation in order to explore the research question we posed: *How does GLUEPS-AR help teachers appropriate immersive environments such as 3DVs and mobile AR in their current educational practice and technological ecology of the classroom with an affordable orchestration effort?*

The evaluation relayed in a qualitative research study [Cohen et al. 2007], wherein a teacher (with pedagogical background and 5 years of teaching expertise) used GLUEPS-AR to design, deploy and enact the City Ads learning situation described in [Section 2]. The study involved the 30 students enrolled in a mandatory course about ICT on Education of the first year of the University Degree in Early Childhood Education at the University of Valladolid (Spain). The evaluation was carried out from February to April 2014.

4.1 Method and Evaluation Happenings

For the evaluation, we have followed the Evaluand-oriented Responsive Evaluation Model (EREM) [Jorrín-Abellán and Stake 2009], which is a framework based on a responsive evaluation approach [Stake 2004]. This kind of evaluation process is framed within the interpretive research paradigm [Orlikowski and Baroudi 1991], which does not pursue statistically-significant results, rather aiming to a deep understanding of the particularity and the richness of concrete phenomena [Guba 1981], in this case provided by the use of GLUEPS-AR in an authentic setting.

To explore the research question, we have followed an anticipatory data reduction process [Miles and Huberman 1994] during the evaluation design [see Fig. 3]. Thus, we defined an issue as the main conceptual organizer of the evaluation process, and we split the issue into two more concrete topics, to help us understand the different dimensions within the issue: *the appropriation of immersive environments in the teacher's everyday practice* (topic 1), and *the orchestration support provided by GLUEPS-AR to the teacher* (topic 2). Each topic is explored with a number of informative questions, which are finally mapped to data gathering techniques.

Munoz-Cristobal J.A., Martinez-Mones A., Asensio-Perez J.I., Villagra-Sobrinio S.L. ... 1679

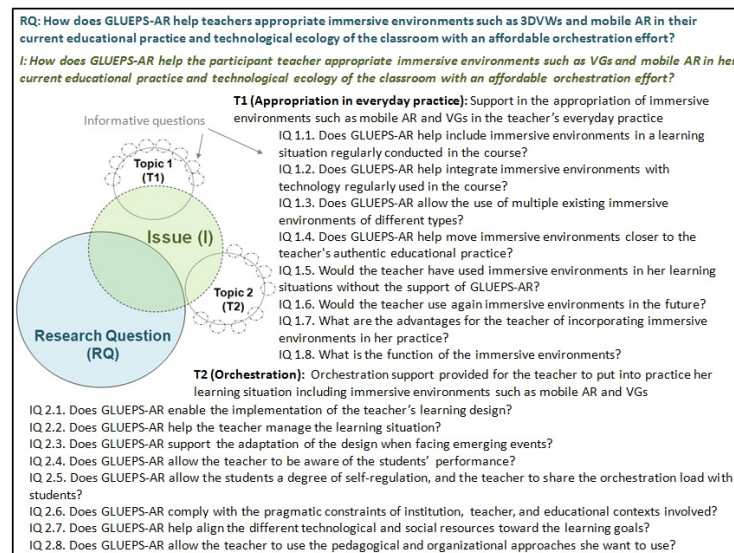

Figure 3: Anticipatory data reduction showing research question (RQ), issue (I), topics (T) and informative questions (IQ).

A profuse set of qualitative data gathering techniques and sources were used during the evaluation [see Fig. 4]: teacher and students' generated artefacts (e.g., learning design, learning resources or emails), screen recordings, naturalistic observations (including pictures, audio, video and observation notes), web based exploratory questionnaires, and interviews. We used different strategies to increase the credibility, transferability, dependability and confirmability of our research, and therefore, to ensure the quality of the research process, attending to our qualitative perspective [Cohen et al. 2007] [Guba 1981] [Miles and Huberman 1994]; prolonged engagement during three months of work with the teacher and persistent observation in the field; acknowledgement of participant opinions, by interviewing the teacher; integration of the thorough collaborative observation reports in a single portfolio, thus enabling a thick description of the phenomenon under scrutiny, reported in detail to the whole evaluation team; peer review within the evaluation team to avoid bias; triangulation of data sources and researchers (five different observers participated in the evaluation, at least two in every observed event) to cross-check data and interpretations. [Fig. 4] illustrates the evaluation flow, divided in three happenings (evaluation events). It also shows the different data gathering techniques and data sources employed, indicating the labels used to refer to them throughout the text.

1680 Muñoz-Cristobal J.A., Martínez-Mones A., Asensio-Perez J.I., Villagra-Sobrino S.L. ...

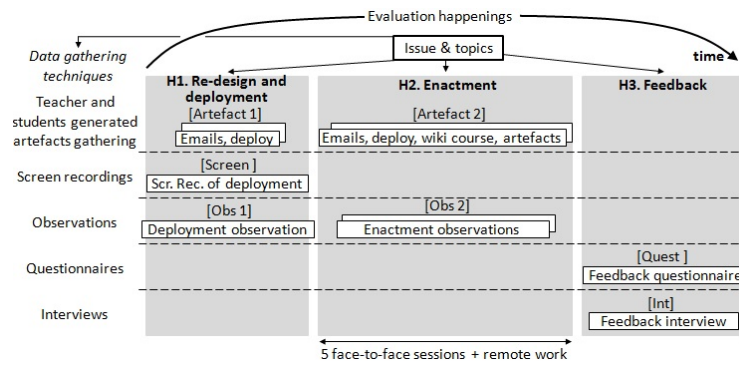

Figure 4: Evaluation happenings and data gathering techniques used during the evaluation.

In a first happening, the teacher reused a previous design she had created months ago [see Muñoz-Cristóbal et al. in press] using the WebCollage authoring tool [Villasclaras-Fernández et al. 2013]. Thus, with occasional support of one of the researchers, she re-designed the City Ads learning situation, particularizing it for the current class and context, as well as including some modifications in the activities. Then, she deployed the design using GLUEPS-AR. GLUEPS-AR is a system for the deployment of learning designs in immersive and non-immersive learning environments. It also enables the teachers to position learning artefacts in different spaces, to embed virtual artefacts in the different environments, and to configure artefact flows, by specifying whether an artefact will be reused in subsequent activities, at the same or a different environment. In this case, the teacher, using GLUEPS-AR, deployed the design in the ULE formed by the wiki-based VLE of the course, the Google Earth and Google Street View VGs, the Junaio and Layar mobile apps, as well as any common QR code reader. She also performed some validation tests to verify that everything had been deployed correctly. The second happening consisted of the enactment of the City Ads learning situation during March 2014 [see Fig. 4]. For the activities 3 and 4 [see Fig. 1] the class was split in two and each half attended different face-to-face sessions. Therefore, in the second happening we collected data from five face-to-face sessions and remote work. In the third and last happening, feedback from the teacher was gathered on April 2014, consisting of a web-based questionnaire and an interview.

4.2 Results

This section presents the main findings obtained in the evaluation study, classified using the topics defined in the anticipatory data reduction process [see Fig. 3], with selected excerpts of evidence supporting these findings.

Munoz-Cristobal J.A., Martinez-Mones A., Asensio-Perez J.I., Villagra-Sobrino S.L. ... 1681

4.2.1 Appropriation in Everyday Practice (Topic 1)

This topic has been explored deriving informative questions to study both the teacher appropriation of the immersive environments involved and whether GLUEPS-AR promoted their incorporation in her educational practice. Results were positive regarding the inclusion of AR and VGs in the learning situation that had been regularly conducted in the same course the previous years. Also, AR and VGs were integrated with the widespread technologies used frequently by the teacher, such as the wiki-based VLE of the course and some Web 2.0 tools like Google Drive [Quest, Int, Obs 2] (the teacher rated 6, “*Strongly agree*”, in a 1-6 scale the two assertions stating that GLUEPS-AR allowed her such inclusion and integration [Quest]; she also declared that “*The wiki is the virtual platform we use regularly in the course [...]. It is a familiar environment for the students and therefore it is important to be able to continue using the same platform that we use in other activities*” [Quest]).

In addition, GLUEPS-AR enabled the use of different existing AR applications and VGs [Quest, Int, Obs 2] (the teacher rated 6, “*Strongly agree*”, in a 1-6 scale, the assertion that GLUEPS-AR allowed her to include in the design multiple existing VGs and AR apps [Quest]). The teacher valued it as an important feature that provides flexibility to adapt the design to different technological constraints, contexts and teacher needs (“*It is important to provide teachers with multiple possibilities, because each person designs in a different way, and has different interests. Thus, a good system [...] offers different possibilities for adapting to different tools and devices. For instance, maybe Layar does not work well in some devices and Junaio does.*” [Int]).

The teacher acknowledged that GLUEPS-AR helped her to move AR and 3DVWs closer to her everyday practice (she rated 6, “*Strongly agree*”, such assertion in a 1-6 scale [Quest]; it was also confirmed in the interview: “*Yes, because there are things that I would not have imagined I would be able to do. For example, the system provides you with the visualization of resources in Google Earth and Street View*” [Int]). Prior to the evaluation, she considered such immersive technologies interesting and she was curious about them. In spite of her interest, she had not used them because she saw them difficult to embed in her practice (“*several things about AR, 3DVWs, the game-based learning field, etc, were, and still are, very unknown to me. [...] They seemed like science fiction for me, actually. [...] I have read some articles about game-based learning and all that, and I thought it was very interesting, [...] some things for learning history [...] were great. [...] But of course I thought they were very complicated*” [Int]). Thus, she recognized that she would not have used 3DVWs without GLUEPS-AR, and despite she had thought about using AR, she did not dare to do it [Quest, Int]. However, after conducting the learning situation, she indicated in both the questionnaire and the interview, that she would use immersive technologies again in the future (“*I will use them for sure. The next year I will modify this design and I will use it, with modifications. I have to think how to make AR and 3DVWs transversal in another block of the course, to get a higher impact in the WebQuest, which is the multimedia didactic resource they have to elaborate at the end of the course*” [Int]). Some of the advantages she considered for incorporating immersive environments had to do with carrying out authentic ubiquitous learning experiences, and also with the possibility of enriching the educational resources in multiple disciplines (“*to be able to design situations that really promote ubiquitous*

1682 Munoz-Cristobal J.A., Martinez-Mones A., Asensio-Perez J.I., Villagra-Sobrino S.L. ...

learning, the possibility of enriching the learning contents in different disciplines [...], improving the student's interactivity, an inquiry based learning, the possibility of a 3D view of monuments, constructions, museums, [...] [Quest]; *"In addition, the students have the possibility of walking through the [virtual] city, and see where the ads are geopositioned"* [Int]). The main drawback that she perceived was that she would need time for increasing her knowledge about these immersive technologies and the pedagogical possibilities they provide [Quest, Int].

Finally, the immersive environments played an instrumental role toward the objective of seamlessly connecting the different physical and virtual spaces of the learning situation [Quest, Int, Obs 2]. An example of this role is that the 3D view of the VGs was mostly used for creating geopositioned artefacts (*"the [virtual] walk in Google Earth isn't long, just enough to visit the picture and create the associated document"* [Obs 2]).

4.2.2 Orchestration (Topic 2)

For the exploration of this topic we have used the orchestration framework of [Prieto et al. 2011], since it is a generic conceptualization that takes into account multiple aspects that different approaches in the TEL literature encompass under the umbrella of orchestration: design, management, adaptation, awareness, roles of the teachers and other actors, pragmatism, alignment and theories.

Evaluation evidence indicates that GLUEPS-AR helped the teacher in the multiple aspects of orchestration. GLUEPS-AR enabled the teacher to implement, with eventual support, her learning *design* in a ULE formed by a wiki-based VLE, Web 2.0 tools, mobile AR apps and VGs [Artefact 1&2, Screen, Obs 1, Quest, Int] (*"I totally agree. The system enables the deployment of the learning design. But about doing it completely alone the first time..., I think that a little help is needed at a first stage. Otherwise I should have studied the manual, which I didn't"* [Int]).

She also admitted that GLUEPS-AR helped her in the *management* of the learning situation by enabling her to structure its activities for different groups, and through the automatic creation of artefacts (she rated 6, *"Strongly agree"*, in a 1-6 scale the three assertions regarding the help provided by the system for managing the learning situation, the groups of students, and the educational tools and resources [Quest]; she also recognized that *"GLUEPS-AR also allowed the automatic deployment of the groups in the wiki, which is an advantage, because in general, I have to create the groups manually"* and *"[regarding the automatic creation of tool instances] that's great, because without that functionality, I would have had to create manually document by document, which would have been like hell. It is wonderful that it is directly deployed"* [Int]). She considered affordable the time devoted to GLUEPS-AR, acknowledging that it would be reduced with some more practice [Quest, Int]. It took her 57 minutes re-designing her learning situation using WebCollage and 46 deploying it using GLUEPS-AR [Screen, Obs 1]. Subsequent refinements in the design were performed quickly by the teacher herself using the GLUEPS-AR user interface [Artefact 1&2]. In addition, she recognised that GLUEPS-AR saved time in the overall learning situation, since in the previous years several operations had to be performed manually, such as the uploading of pictures and their positioning in a map (*"Now we save time. For example, for taking the pictures, previously the students took and stored them in their mobiles, and they had*

Munoz-Cristobal J.A., Martinez-Mones A., Asensio-Perez J.I., Villagra-Sobrino S.L. ... 1683

to load them in their computers and upload them to the VLE. Now, everything is automatically geopositioned" [Int]). GLUEPS-AR enabled the teacher not only to fine-tune the design after its first deployment and between sessions, but also to *adapt* it when emerging events occurred [Artefact 1&2, Quest, Int, Obs 2]. For instance, during the sessions, she changed the groups' configuration, she included new learning resources to the learning design, and she modified the accessibility of several artefacts in order to allow their access from different environments (e.g., from VGs, from the wiki or from AR) (e.g., some observation notes illustrate this feature, such as *"the teacher goes to her computer. She has to add a student to a group. She accesses the GLUEPS-AR user interface and does it in less than two minutes"* and *"The teacher tells us that the use of GLUEPS-AR for a deployment during a session is amazing. She has added a new resource (a tool's manual), deployed it, and it already appears in the wiki"* [Obs 2]). Also, one of the components of the architecture failed during one day (it reached its maximum configured java memory, since it had not been used previously with such a high load as the one produced with the uploading of about 300 pictures). Consequently, several pictures could not be uploaded and geopositioned by the students from the location in which they were taken. GLUEPS-AR allowed the teacher to change the positioning type of the buckets, enabling students to upload and position the pictures later, from their homes or from the classroom (*"[...] some students had problems for the automatic uploading of pictures. [...] Having the possibility of configuring the bucket to allow that the students manually geoposition [the pictures] is great, because there is a back-up plan [...]. And I think it is very relevant in these learning situations [...]"* [Int]). The feedback from the teacher was very positive in this aspect, acknowledging that with GLUEPS-AR she was able to change the activities at runtime (she rated 6, *"Strongly agree"*, in a 1-6 scale the seven assertions regarding the support provided by GLUEPS-AR to adapt and modify the design and its elements (activities, groups, resources, etc) [Quest]; she also recognized that *"the possibility of making changes at runtime is what I value most. [...] making changes is super-easy"* [Int]; *"The teacher tells us that GLUEPS-AR is useful and usable, and now she can go calmly to the classroom, because if she has forgotten something [in the system], she can do it during the class"* [Obs 2]).

The GLUEPS-AR user interface acted also as a dashboard for the teacher, allowing her to review and assess the students' work (she rated 5, *"Agree"*, in a 1-6 scale the different assertions regarding the GLUEPS-AR support to the awareness of students actions during and after the end of the activities in both, physical and virtual spaces [Quest]). In addition, she was able to review the work using the wiki and the VGs (*"I was able also to access Google Earth and know if each group was uploading correctly the pictures [...] this way we identified the persons who had had problems in the automatic uploading of pictures"* [Int]). The main limitation of the awareness aspect was that the teacher did not have enough time during the enactment sessions to review the work that was being carried out by the students [Quest, Int] (*"[...] the challenge is the [short] time we have to review in situ so much information and provide feedback to the students"* [Quest]). She indicated that technology could provide solutions with respect to this facet, for instance by providing summarized information of key indicators [Int].

The role of the students in the orchestration of a ubiquitous learning situation like City Ads can be an essential factor to make it affordable. By using learning buckets,

1684 Munoz-Cristobal J.A., Martinez-Mones A., Asensio-Perez J.I., Villagra-Sobrino S.L. ...

GLUEPS-AR allowed moving part of the orchestration load from the teacher to the students, giving them a level of self-regulation in the management of artefacts within the different immersive and not immersive environments (wiki, AR apps and VGs) [Quest, Int, Obs 2] (e.g., the teacher acknowledged that *“the orchestration load decreases a lot when you give the students the possibility of deciding what artefacts they create, not being myself who creates every document wherein the students have to work. In addition, they are more active in the process [...]”* [Int]; such student self-regulation was also observed, e.g., *“These two students are creating documents for the [analysis of the] pictures. They are concentrated on working”* [Obs 2]). The students created finally 570 artefacts (e.g., pictures uploaded to Picasa or Google Drive Documents) [Artefact 2].

Evaluation evidence shows that GLUEPS-AR provided the teacher with a pragmatic mean for conducting the City Ads scenario, since it fitted with her technological and pedagogical constraints, as well as with those of the institution and context [Quest, Int] (*“it fitted very well with my needs as a teacher [...] A benefit of the system is that it gives you new possibilities, which you haven’t even thought they could exist. [...] Now our institutions ask us for using VLEs [...] and active methodologies, and since GLUEPS-AR supports these requirements, it fits well with these constraints”* [Int]). The teacher considered GLUEPS-AR easy to use [Quest, Int] (she rated 5, “Agree”, or 6, “Strongly agree”, the different assertions regarding the easiness and usefulness of the system), although some minor usability problems were detected in the user interface [Quest, Int, Obs 2] (*“Maybe the fields required to complete for creating artefacts are confusing”* [Quest]; *“She has some problems with the interface: too many scrolls, etc.”* [Obs 2]). The teacher expressed her intention of using GLUEPS-AR the next term to conduct again the City Ads scenario (she rated 6, “Strongly agree”, in a 1-6 scale the three assertions regarding its future use [Quest], and she confirmed it in the interview: *“Yes, I’m motivated to learn. Really, I’ll do. Moreover, I already know what I’m going to change the next year”* [Int]).

Another interesting aspect was that GLUEPS-AR helped the teacher align the different technological and social resources as a necessary means for achieving the learning goals. GLUEPS-AR converted a set of independent physical and virtual, immersive and non-immersive spaces in a ULE, where students were able to learn seamlessly (she rated 5, “Agree”, and 6, “Strongly agree”, the assertions regarding the integration of the different spaces, as well as the continuity of the learning activities performed between them [Quest]; she also confirmed it during the interview: *“yes, because in the end, all the different learning spaces were well defined and very clear [...] ‘First, we go to the streets and take pictures. We geoposition them in Google Earth. We arrive to the classroom, create the documents and geoposition them close to the pictures in Google Earth. ¿And where do we access all the information of the activity? In the wiki’. I think [all the spaces] were very clear”* [Int]). However, she found that not all learning goals were achieved by some students (e.g., that was the case of the use of the AR browsers and the subsequent students’ reports about the potential affordances of AR in education, where several students just copied information from Internet [Int]). She recognised that this problem was due to a lack of an assessment design she should have created, as well as to the excess of students’ workload, not being related to GLUEPS-AR (*“I think I made them suffer so much because there were few classroom-hours and too many things I asked them to do. [...]”*

Munoz-Cristobal J.A., Martinez-Mones A., Asensio-Perez J.I., Villagra-Sobrinio S.L. ... 1685

There are students that didn't work very well. The evaluation criteria should have been clearer to help them achieve the objectives, because we had never carried out such a deep analysis, and it was also new for me [...]. Therefore, I think that if they haven't achieved the learning objectives, the responsibility is shared between them and me" [Int].

Finally, GLUEPS-AR did not modify significantly the pedagogical and organizational *theories* of the teacher [Quest, Int], although when she reviewed the performance of the students, she realized she should modify her design in subsequent years (*"When I made the design I used the pedagogical methodologies I wanted to use and I was happy with my design. But afterwards I realized that there are several things to improve and refine"* [Int]).

5 Conclusions

City Ads is a ubiquitous learning scenario that integrates immersive technologies, such as mobile AR and VGs, with other widespread technologies used in education, like a wiki-based VLE and Web 2.0 tools. The immersive environments enriched a learning situation that had been regularly conducted previously. The City Ads scenario illustrates several existing challenges that refer to the appropriation of immersive environments in everyday educational practice, namely, the inclusion of such environments in learning situations conducted regularly by the teachers, their integration with the widespread technologies already used by the educators, as well as the support to the orchestration of the resulting learning situations.

The evidence gathered in the evaluation reported in this paper indicates that GLUEPS-AR aided the involved teacher to appropriate immersive environments such as mobile AR and VGs in her educational practice, enabling her to design, deploy and enact the City Ads learning situation. Moreover, GLUEPS-AR helped her to overcome the difficulties of orchestrating the complex ecology of technological and social resources created with the integration of such immersive technologies.

Although the teacher included and orchestrated immersive technologies that she recognized would not have incorporated without the use of GLUEPS-AR, some of the immersive affordances of the environments had a limited use. For example, the teacher did not include in her design collaboration in VGs using avatars and chats since she did not consider it necessary to achieve the learning goals. We plan further research exploring learning situations with higher use of interaction and presence in the immersive environments.

One of the main benefits of using VGs rather than other more classical 3DVWs like Second Life is their widespread use, which may contribute to their adoption by the teachers. However, VGs have also limitations, such as the current lack of 3D buildings in some areas in Google Earth. We plan to further explore the integration of other more classical 3DVWs, as well as other types of environments (e.g., tabletops and AR/VR glasses). Other open issues, which have not been explored in this case, are the analysis of these situations from the point of view of the students, to analyze the achievement of the learning goals and the acquisition of knowledge by the participants, as well as the study of GLUEPS-AR scalability, to evaluate whether it enables the set-up of more massive scenarios. Also, further research is necessary to

1686 *Munoz-Cristobal J.A., Martinez-Mones A., Asensio-Perez J.I., Villagra-Sobrino S.L. ...*

explore the effects of different didactic and pedagogical approaches in the teacher appropriation and orchestration of learning situations such as City Ads.

Acknowledgements

This research has been partially funded by the Spanish Project TIN2011-28308-C03-02 and the European Project 531262-LLP-2012-ES-KA3-KA3MP. The authors thank Mario Marinero, Judith Samaniego, Quico Arribas, Angélica Lozano, Rafael Cano and the rest of the GSIC/EMIC research team for their ideas and support.

References

- [Alario-Hoyos and Wilson 2010] Alario-Hoyos, C. and Wilson, S.: "Comparison of the main alternatives to the integration of external tools in different platforms"; Proceedings of the International Conference of Education, Research and Innovation, ICERI 2010 (2010), 3466-3476.
- [Alcañiz et al. 2010] Alcañiz, M., Contero, M., Perez-Lopez, D.C., and Ortega, M.: Augmented Reality Technology for Education. In: Soomro, S. (ed.) *New Achievements in Technology Education and Development*. pp. 247-256. InTech, (2010)
- [Billinghurst and Duenser 2012] Billinghurst, M. and Duenser, A.: "Augmented Reality in the Classroom"; *Computer*, 45, 7 (2012), 56-63.
- [Callaghan et al. 2009] Callaghan, M.J., McCusker, K., Losada, J.L., Harkin, J.G., and Wilson, S.: "Engineering Education Island: Teaching Engineering in Virtual Worlds"; *Innovation in Teaching and Learning in Information and Computer Sciences*, 8, 3 (2009), 2-18.
- [Cohen et al. 2007] Cohen, L., Manion, L., and Morrison, K.: "Research methods in education"; Routledge (2007)
- [Chen and Choi 2010] Chen, X. and Choi, J.H.: "Designing Online Collaborative Location-Aware Platform for History Learning"; *Journal of Educational Technology Development and Exchange*, 3, 1 (2010), 13-26.
- [Dede 2009] Dede, C.: "Immersive Interfaces for Engagement and Learning"; *Science*, 323, 5910 (2009), 66-69.
- [Dede et al. 2004] Dede, C., Nelson, B., Ketelhut, D.J., Clarke, J., and Bowman, C.: "Design-based research strategies for studying situated learning in a multi-user virtual environment"; Proceedings of the 6th international conference on Learning sciences. ICLS '04 (2004), 158-165.
- [Di Serio et al. 2013] Di Serio, Á., Ibáñez, M.B., and Delgado Kloos, C.: "Impact of an augmented reality system on students' motivation for a visual art course"; *Computers & Education*, 68, 0 (2013), 586-596.
- [Dickey 2005] Dickey, M.D.: "Three-dimensional virtual worlds and distance learning: two case studies of Active Worlds as a medium for distance education"; *British Journal of Educational Technology*, 36, 3 (2005), 439-451.
- [Dordevic and Wild 2012] Dordevic, M.M. and Wild, S.C.: "Avatars and multi-student interactions in Google Earth-based virtual field experiences"; *Geological Society of America Special Papers*, 492, (2012), 315-321.

Munoz-Cristobal J.A., Martinez-Mones A., Asensio-Perez J.I., Villagra-Sobrino S.L. ... 1687

[Dörner et al. 2011] Dörner, R., Lok, B., and Broll, W.: Social Gaming and Learning Applications: A Driving Force for the Future of Virtual and Augmented Reality? In: Brunnett, G., Coquillart, S., Welch, G. (eds.) *Virtual Realities*. pp. 51-76. Springer Vienna, (2011)

[Duncan et al. 2012] Duncan, I., Miller, A., and Jiang, S.: "A taxonomy of virtual worlds usage in education"; *British Journal of Educational Technology*, 43, 6 (2012), 949-964.

[Facer et al. 2004] Facer, K., Joiner, R., Stanton, D., Reid, J., Hull, R., and Kirks, D.: "Savannah: mobile gaming and learning?"; *Journal of Computer Assisted Learning*, 20, 6 (2004), 399-409.

[Fernández-Gallego et al. 2010] Fernández-Gallego, B., Lama, M., Vidal, J.C., Sánchez, E., and Bugarín, A.: "OPENET4VE: A Platform for the Execution of IMS LD Units of Learning in Virtual Environments"; *IEEE 10th International Conference on Advanced Learning Technologies (ICALT) (2010)*, 472-474.

[Fernández-Panadero and Delgado Kloos 2013] Fernández-Panadero, C. and Delgado Kloos, C.: "PhyMEL. A Framework to Integrate Physical, Mental and Emotional Learning in Meaningfull Experiences and Multidimensional Reports"; *3rd European Immersive Education Summit (EiED'13)*, London, UK (2013), 203-208.

[Gregory et al. 2013] Gregory, S. et al.: "Virtual worlds in Australian and New Zealand higher education : remembering the past, understanding the present and imagining the future"; *ASCILITE 2013 "Electric Dreams"*, Macquarie University, Sydney, Australia (2013), 312-324.

[Guba 1981] Guba, E.: "Criteria for assessing the trustworthiness of naturalistic inquiries"; *Educational Communication and Technology Journal*, 29, 2 (1981), 75-91.

[Ibáñez et al. 2012] Ibáñez, M.B., Maroto, D., García Rueda, J.J., Leony, D., and Delgado Kloos, C.: "Architecture for Collaborative Learning Activities in Hybrid Learning Environments"; *Journal of Universal Computer Science*, 18, 15 (2012), 2187-2202.

[Izadi et al. 2002] Izadi, S., Fraser, M., Benford, S., Flintham, M., Greenhalgh, C., Rodden, T., and Schnädelbach, H.: "Citywide: Supporting Interactive Digital Experiences Across Physical Space"; *Personal and Ubiquitous Computing*, 6, 4 (2002), 290-298.

[Jarmon et al. 2008] Jarmon, L., Traphagan, T., and Mayrath, M.: "Understanding project-based learning in Second Life with a pedagogy, training, and assessment trio"; *Educational Media International*, 45, 3 (2008), 157-176.

[Jorrín-Abellán and Stake 2009] Jorrín-Abellán, I.M. and Stake, R.E.: "Does Ubiquitous Learning Call for Ubiquitous Forms of Formal Evaluation? An Evaluand Oriented Responsive Evaluation Model"; *Ubiquitous Learning: An International Journal*, 1, 3 (2009), 71-82.

[Kamarainen et al. 2013] Kamarainen, A.M., Metcalf, S., Grotzer, T., Browne, A., Mazzuca, D., Tutwiler, M.S., and Dede, C.: "EcoMOBILE: Integrating augmented reality and probeware with environmental education field trips"; *Computers & Education*, 68, 0 (2013), 545-556.

[Kaufmann and Schmalstieg 2002] Kaufmann, H. and Schmalstieg, D.: "Mathematics and geometry education with collaborative augmented reality"; *ACM SIGGRAPH 2002 conference abstracts and applications. SIGGRAPH '02*, New York, NY, USA (2002), 37-41.

[Kerawalla et al. 2006] Kerawalla, L., Luckin, R., Seljeflot, S., and Woolard, A.: "'Making it real": exploring the potential of augmented reality for teaching primary school science"; *Virtual Reality*, 10, 3 (2006), 163-174.

[Klopfer et al. 2011] Klopfer, E., Sheldon, J., Perry, J., Rosenheck, L., Squire, K., Mathews, J., Shapiro, R.B., Coulter, B., and Dunleavy, M.: "Augmented reality games: place-based digital

1688 Muñoz-Cristobal J.A., Martinez-Mones A., Asensio-Perez J.I., Villagra-Sobrino S.L. ...

learning"; Proceedings of the 9th International CSCL Conference, Hong Kong, China (2011), 1023-1028.

[Koper 2005] Koper, R.: An Introduction to Learning Design. In: Koper, R., Tattersall, C. (eds.) Learning Design. A Handbook on Modelling and Delivering Networked Education and Training, pp. 3-20. Springer, (2005)

[Li et al. 2004] Li, L., Zheng, Y., Ogata, H., and Yano, Y.: "A framework of ubiquitous learning environment"; The Fourth International Conference on Computer and Information Technology (CIT 2004), Wuhan, China (2004), 345-350.

[Lim et al. 2006] Lim, C.P., Nonis, D., and Hedberg, J.: "Gaming in a 3D multiuser virtual environment: engaging students in Science lessons"; British Journal of Educational Technology, 37, 2 (2006), 211-231.

[Livingstone and Kemp 2008] Livingstone, D. and Kemp, J.: "Integrating Web-Based and 3D Learning Environments: Second Life Meets Moodle"; UPGRADE, 9, 3 (2008), 8-14.

[Maroto et al. 2011] Maroto, D., Leony, D., Delgado Kloos, C., Ibáñez, M.B., and Rueda, J.J.G.: "Orchestrating learning activities in 3D virtual worlds: IMS-LD in open wonderland"; Proceedings of the 6th European conference on Technology enhanced learning: towards ubiquitous learning. EC-TEL'11, Berlin, Heidelberg (2011), 455-460.

[Mennecke et al. 2008] Mennecke, B., Hassall, L.M., and Triplett, J.: "The Mean Business of Second Life: Teaching Entrepreneurship, Technology and e-Commerce in Immersive Environments"; Journal of Online Learning and Teaching, 4, 3 (2008), 339-348.

[Miles and Huberman 1994] Miles, M.B. and Huberman, A.M.: "Qualitative Data Analysis. An Expanded Sourcebook"; SAGE Publications Inc. (1994)

[Muñoz-Cristóbal et al. 2013] Muñoz-Cristóbal, J.A., Prieto-Santos, L.P., Asensio-Pérez, J.I., Jorrín-Abellán, I.M., Martínez-Monés, A., and Dimitriadis, Y.: "Sharing the Burden: Introducing Student-Centered Orchestration in Across-Spaces Learning Situations"; Proceedings of the 8th European Conference on Technology Enhanced Learning (EC-TEL), Paphos, Cyprus (2013), 621-622.

[Muñoz-Cristóbal et al. in press] Muñoz-Cristóbal, J.A., Prieto, L.P., Asensio-Pérez, J.I., Martínez-Monés, A., Jorrín-Abellán, I.M., and Dimitriadis, Y.: "Coming down to Earth: Helping teachers use 3D virtual worlds in across-spaces learning situations"; Educational Technology & Society, (in press)

[Okada et al. 2001] Okada, M., Tarumi, H., Yoshimura, T., and Moriya, K.: "Collaborative environmental education using distributed virtual environment accessible from real and virtual worlds"; SIGAPP Applied Computing Review, 9, 1 (2001), 15-21.

[Orlikowski and Baroudi 1991] Orlikowski, W.J. and Baroudi, J.J.: "Studying Information Technology in Organizations: Research Approaches and Assumptions"; Information Systems Research, 2, 1 (1991), 1-28.

[Peña-Rios et al. 2013] Peña-Rios, A., Callaghan, V., Gardner, M., and Alhaddad, M.J.: "xReality interactions within an immersive blended reality learning space"; 3rd European Immersive Education Summit (EiED'13), London, UK (2013), 26-35.

[Pérez-Sanagustín et al. 2011] Pérez-Sanagustín, M., Ramírez-Gonzalez, G., Hernández-Leo, D., Muñoz-Organero, M., Santos, P., Blat, J., and Delgado Kloos, C.: "Discovering the campus together: A mobile and computer-based learning experience"; Journal of Network and Computer Applications, 35, 1 (2011), 167-188.

Munoz-Cristobal J.A., Martinez-Mones A., Asensio-Perez J.I., Villagra-Sobrino S.L. ... 1689

- [Pourmirza and Gardner 2013] Pourmirza, S. and Gardner, M.: "Integrating a Facebook Group with the Open Wonderland Environment"; 3rd European Immersive Education Summit (EiED'13), London, UK (2013), 17-22.
- [Prieto et al. 2011] Prieto, L.P., Dlab, M.H., Gutiérrez, I., Abdulwahed, M., and Balid, W.: "Orchestrating technology enhanced learning: a literature review and a conceptual framework"; *International Journal of Technology Enhanced Learning*, 3, 6 (2011), 583-598.
- [Rakshit and Ogneva-Himmelberger 2008] Rakshit, R. and Ogneva-Himmelberger, Y.: "Application of Virtual Globes in Education"; *Geography Compass*, 2, 6 (2008), 1995-2010.
- [Santos et al. 2011] Santos, P., Pérez-Sanagustín, M., Hernández-Leo, D., and Blat, J.: "QuesTInSitu: From tests to routes for assessment in situ activities"; *Computers & Education*, 57, 4 (2011), 2517-2534.
- [Schaf et al. 2012] Schaf, F.M., Paladini, S., and Pereira, C.E.: "3D AutoSysLab Prototype - A Social, Immersive and Mixed Reality Approach for Collaborative Learning Environments"; *International Journal of Engineering Pedagogy*, 2, 2 (2012), 15-22.
- [Sharples 2013] Sharples, M.: "Shared orchestration within and beyond the classroom"; *Computers & Education*, 69, 0 (2013), 504-506.
- [Spikol and Eliasson 2010] Spikol, D. and Eliasson, J.: "Lessons from Designing Geometry Learning Activities that Combine Mobile and 3D Tools"; *Proceedings of the 6th IEEE International Conference on Wireless, Mobile and Ubiquitous Technologies in Education (WMUTE)*, Kaohsiung, Taiwan (2010), 137-141.
- [Stake 2004] Stake, R.E.: "Standards-Based and Responsive Evaluation"; SAGE Publications Inc. (2004)
- [Ternier et al. 2012] Ternier, S., Klemke, R., Kalz, M., van Ulzen, P., and Specht, M.: "ARLearn: augmented reality meets augmented virtuality"; *Journal of Universal Computer Science*, 18, 15 (2012), 2143-2164.
- [Villasclaras-Fernández et al. 2013] Villasclaras-Fernández, E., Hernández-Leo, D., Asensio-Pérez, J.I., and Dimitriadis, Y.: "Web Collage: An implementation of support for assessment design in CSCL macro-scripts"; *Computers & Education*, 67, 0 (2013), 79-97.
- [Vlahakis et al. 2002] Vlahakis, V., Ioannidis, N., Karigiannis, J., Tsotros, M., Gounaris, M., Stricker, D., Gleue, T., Daehne, P., and Almeida, L.: "Archeoguide: an augmented reality guide for archaeological sites"; *Computer Graphics and Applications, IEEE*, 22, 5 (2002), 52-60.
- [Warburton 2009] Warburton, S.: "Second Life in higher education: Assessing the potential for and the barriers to deploying virtual worlds in learning and teaching"; *British Journal of Educational Technology*, 40, 3 (2009), 414-426.
- [Wu et al. 2013] Wu, H.-K., Lee, S.W.-Y., Chang, H.-Y., and Liang, J.-C.: "Current status, opportunities and challenges of augmented reality in education"; *Computers & Education*, 62, (2013), 41-49.
- [Zurita et al. 2014] Zurita, G., Baloian, N., and Frez, J.: "Using the cloud to develop applications supporting geo-collaborative Situated Learning"; *Future Generation Computer Systems*, 34, 0 (2014), 124-137.

References

- [Adr93] W. R. Adrion. Research methodology in software engineering: Summary of the dagstuhl workshop on future directions on software engineering. *SIGSoft Software Engineering Notes*, 18(1):36–37, 1993.
- [AH12] C. Alario-Hoyos. *GLUE!: An Architecture for the Integration of External Tools in Virtual Learning Environments*. Phd thesis, University of Valladolid, Spain, 2012.
- [Avi99] D. E. Avison, F. Lau, M. D. Myers, and P. A. Nielsen. Action research. *Communications of the ACM*, 42(1):94–97, 1999.
- [Azu01] R. Azuma, Y. Baillet, R. Behringer, S. Feiner, S. Julier, and B. MacIntyre. Recent advances in augmented reality. *IEEE Computer Graphics and Applications*, 21(6):34–47, 2001.
- [Bal09] N. Balacheff, R. Bottino, F. Fischer, L. Hofmann, M. Joubert, B. Kieslinger, S. Lindstaedt, S. Manca, M. Ney, F. Pozzi, R. Sutherland, K. Verbert, S. Timmis, F. Wild, P. Scott, and M. Specht. D1.1 the STELLAR vision and strategy statement. Final report 1.0, STELLAR, 2009.
- [Ber89] B. L. Berg. *Qualitative Research Methods for the Social Sciences*. Allyn and Bacon, Needham Heights, MA, USA, 1989.
- [BL05] M. L. Bote-Lorenzo. *Gridcole, un sistema maleable basado en servicios grid para el apoyo del aprendizaje colaborativo guiado*. Phd thesis, University of Valladolid, 2005.
- [Bru08] B. C. Bruce. Ubiquitous learning, ubiquitous computing, and lived experience. In W. Cope and M. Kalantzis, editors, *Ubiquitous learning*, pages 21–30. University of Illinois Press, Champaign, IL, 2008.
- [Cal09] M. J. Callaghan, K. McCusker, J. L. Losada, J. G. Harkin, and S. Wilson. Engineering education island: Teaching engineering in virtual worlds. *Innovation in Teaching and Learning in Information and Computer Sciences*, 8(3):2–18, 2009.
- [Cha06] T.-W. Chan, J. Roschelle, S. Hsi, K. Kinshuk, M. Sharples, T. Brown, C. Patton, J. Cherniavsky, R. Pea, C. Norris, E. Soloway, N. Balacheff, M. Scardamalia, P. Dillenbourg, C.-K. Looi, M. Milrad, and U. Hoppe. One-to-one technology-enhanced learning: An opportunity for global research collaboration. *Research and Practice in Technology Enhanced Learning*, 1(1):3–29, 2006.

- [Cio04] L. Ciolfi. Understanding spaces as places: Extending interaction design paradigms. *Cognition, Technology and Work*, 6(1):37–40, 2004.
- [Coh07] L. Cohen, L. Manion, and K. Morrison. *Research methods in education*. Routledge, Abingdon, UK, 2007.
- [Con14] M. A. Conde, F. García-Peñalvo, M. Alier, E. Mayol, and C. Fernández-Llamas. Implementation and design of a service-based framework to integrate personal and institutional learning environments. *Science of Computer Programming*, 88:41–53, 2014.
- [Cop10] B. Cope and M. Kalantzis. Ubiquitous learning: An agenda for educational transformation. In B. Cope and M. Kalantzis, editors, *Ubiquitous Learning*, pages 3–14. University of Illinois Press, 2010.
- [Cre09] J. W. Creswell. *Research Design. Qualitative, Quantitative, and Mixed Methods Approaches*. SAGE Publications Inc, 2009.
- [Cue13] S. Cuendet, Q. Bonnard, S. Do-Lenh, and P. Dillenbourg. Designing augmented reality for the classroom. *Computers & Education*, 68:557–569, 2013.
- [Dal10] B. Dalgarno and M. J. W. Lee. What are the learning affordances of 3-d virtual environments? *British Journal of Educational Technology*, 41(1):10–32, 2010.
- [Ded96] C. Dede, M. Salzman, and R. Loftin. The development of a virtual world for learning newtonian mechanics. In P. Brusilovsky, P. Kommers, and N. Streitzi, editors, *Multimedia, Hypermedia, and Virtual Reality Models, Systems, and Applications*, volume 1077 of *Lecture Notes in Computer Science*, pages 87–106. Springer Berlin Heidelberg, 1996.
- [Ded09] C. Dede. Immersive interfaces for engagement and learning. *Science*, 323(5910):66–69, 2009.
- [Dic03] M. D. Dickey. Teaching in 3d: Pedagogical affordances and constraints of 3d virtual worlds for synchronous distance learning. *Distance Education*, 24(1):105–121, 2003.
- [Dil02] P. Dillenbourg, D. Schneider, and P. Synteta. Virtual learning environments. In A. Dimitracopoulou, editor, *Proceedings of the 3rd Hellenic Conference on Information & Communication Technologies in Education*, pages 3–18, Greece, 2002. Kastaniotis Editions.
- [Dil09] P. Dillenbourg, S. Järvelä, and F. Fischer. The evolution of research on computer-supported collaborative learning. In N. Balacheff, S. Ludvigsen, T. Jong, A. Lazonder, and S. Barnes, editors, *Technology-Enhanced Learning*, pages 3–19. Springer Netherlands, 2009.
- [Dil10] P. Dillenbourg and P. Jermann. Technology for classroom orchestration. In M. S. Khine and I. M. Saleh, editors, *New Science of Learning Cognition Computers and Collaboration in Education*, pages 1–20. Springer New York, 2010.
- [DJ10] T. De Jong, W. R. Van Joolingen, A. Giemza, I. Girault, U. Hoppe, J. Kindermann, A. Kluge, A. W. Lazonder, V. Vold, A. Weinberger, S. Weinbrenner, A. Wichmann,

- A. Anjewierden, M. Bodin, L. Bollen, C. D'Ham, J. Dolonen, J. Engler, C. Geraedts, H. Grosskreutz, T. Hovardas, R. Julien, J. Lechner, S. Ludvigsen, Y. Matteman, y. Meistadt, B. Næss, M. Ney, M. Pedaste, A. Perritano, M. Rinket, H. Von Schlanbusch, T. Sarapuu, F. Schulz, J. Sikken, J. Slotta, J. Toussaint, A. Verkade, C. Wajeman, B. Wasson, Z. C. Zacharia, and M. Van Der Zanden. Learning by creating and exchanging objects: The SCY experience. *British Journal of Educational Technology*, 41(6):909–921, 2010.
- [DK12] C. Delgado Kloos, D. Hernández-Leo, and J. I. Asensio-Pérez. Technology for learning across physical and virtual spaces. *Journal of Universal Computer Science*, 18(15):2093–2096, 2012.
- [Dys09] L. E. Dyson, A. Litchfield, E. Lawrence, R. Raban, and P. Leijdekkers. Advancing the m-learning research agenda for active, experiential learning: Four case studies. *Australasian Journal of Educational Technology*, 25(2):250–267, 2009.
- [Ecm13] Ecma International. The json data interchange format. ECMA-404 The JSON Data Interchange Standard, 1st Edition, October 2013.
- [Fac04] K. Facer, R. Joiner, D. Stanton, J. Reid, R. Hull, and D. Kirks. Savannah: mobile gaming and learning? *Journal of Computer Assisted Learning*, 20(6):399–409, 2004.
- [GL13] V. Gallego-Lema, B. Rubia-Avi, J. A. Muñoz-Cristóbal, and H. F. Arribas-Cubero. El uso de la realidad aumentada en la formación del profesorado en educación física: un estudio de casos en valladolid. In *XXI Jornadas Universitarias de Tecnología Educativa (JUTE 2013)*, Valladolid, Spain, 2013.
- [GL14] V. Gallego-Lema, J. A. Muñoz-Cristóbal, H. F. Arribas-Cubero, and B. Rubia-Avi. Espacios educativos especulares: un estudio de casos en educación física en el medio natural. In *XXII Jornadas Universitarias de Tecnología Educativa (JUTE 2014)*, pages 167–168, Toledo, Spain, 2014.
- [Gla95] R. L. Glass. A structure-based critique of contemporary computing research. *Journal of Systems and Software*, 28(1):3–7, 1995.
- [Gre01] D. G. Gregg, U. R. Kulkarni, and A. S. Vinzé. Understanding the philosophical underpinnings of software engineering research in information systems. *Information Systems Frontiers*, 3(2):169–183, 2001.
- [Gub81] E. G. Guba. Criteria for assessing the trustworthiness of naturalistic inquiries. *Educational Communication and Technology*, 29(2):75–91, 1981.
- [Gub94] E. G. Guba and Y. S. Lincoln. Competing paradigms in qualitative research. In N. K. Denzin and Y. S. Lincoln, editors, *Handbook of qualitative research*, volume 2, pages 105–117. Sage, 1994.
- [Har96] S. Harrison and P. Dourish. Re-place-ing space: the roles of place and space in collaborative systems. In *Proceedings of the 1996 ACM Conference on Computer Cupported Cooperative Work, CSCW '96*, pages 67–76, Boston, Massachusetts, USA, November 1996. ACM.

- [Hev04] A. R. Hevner, S. T. March, J. Park, and S. Ram. Design science in information systems research. *MIS Quarterly*, 28(1):75–105, 2004.
- [JA09] I. M. Jorrín-Abellán and R. E. Stake. Does ubiquitous learning call for ubiquitous forms of formal evaluation? An evaluation oriented responsive evaluation model. *Ubiquitous Learning: An International Journal*, 1(3):71–82, 2009. Common Ground Publisher, Melbourne, Australia.
- [JA15] I. M. Jorrín-Abellán and J. A. Muñoz-Cristóbal. “The phalanx covenant”: Do we need the x-men to evaluate some ubiquitous learning scenarios? In *Eleventh International Congress of Qualitative Inquiry*, University of Illinois at Urbana-Champaign, USA, May 2015.
- [Jon04] V. Jones and J. H. Jo. Ubiquitous learning environment: An adaptive teaching system using ubiquitous technology. In D. J.-D. R. Atkinson, C. McBeath and R. Phillips, editors, *Beyond the comfort zone: Proceedings of the 21st ASCILITE conference*, pages 468–474, Perth, Australia, December 2004.
- [Kel05] C. Keller. Virtual learning environments: Three implementation perspectives. *Learning, Media and Technology*, 30(3):299–311, 2005.
- [Kit96] B. Kitchenham. DESMET: A method for evaluating software engineering methods and tools. Technical Report TR96-09, Department of Computer Science, University of Keele, Keele, Staffordshire, ST5 5BG. UK, August 1996.
- [Kit97] B. Kitchenham, S. Linkman, and D. Law. DESMET: a methodology for evaluating software engineering methods and tools. *Computing Control Engineering Journal*, 8(3):120–26, June 1997.
- [Klo11] E. Klopfer, J. Sheldon, J. Perry, L. Rosenheck, K. Squire, J. Mathews, R. B. Shapiro, B. Coulter, and M. Dunleavy. Augmented reality games: Place-based digital learning. In *Proceedings of the 9th International Computer-Supported Collaborative Learning Conference*, pages 1023–1028, Hong Kong, China, July 2011.
- [Kna84] K. A. Knafl and M. J. Howard. Interpreting and reporting qualitative research. *Research in Nursing & Health*, 7(1):17–24, 1984.
- [Kol13] I. Kollar and F. Fischer. Orchestration is nothing without conducting – but arranging ties the two together!: A response to Dillenbourg (2011). *Computers & Education*, 69:507–509, 2013.
- [Kop05] R. Koper. An introduction to learning design. In R. Koper and C. Tattersall, editors, *Learning Design. A Handbook on Modelling and Delivering Networked Education and Training*. Springer, 2005.
- [Kra09] D. R. Krathwohl. *Methods of Educational and Social Science Research*. Waveland Press, Inc., third edition, 2009.
- [Kur08] A. Kurti, D. Spikol, and M. Milrad. Bridging outdoors and indoors educational activities in schools with the support of mobile and positioning technologies. *International Journal of Mobile Learning and Organisation*, 2(2):166–186, 2008.

- [Li04] L. Li, Y. Zheng, H. Ogata, and Y. Yano. A framework of ubiquitous learning environment. In *The Fourth International Conference on Computer and Information Technology (CIT 2004)*, pages 345–350, Wuhan, China, September 2004.
- [Lic10] M. Lichtman. *Qualitative Research in Education: A User's Guide*. SAGE Publications Inc., Thousand Oaks, CA, USA, second edition, 2010.
- [Lin09] Y. S. Lincoln and E. G. Guba. The only generalization is: There is no generalization. In R. Gomm, M. Hammersley, and P. Foster, editors, *Case Study Method*. Sage, 2009.
- [Liv08] D. Livingstone and J. Kemp. Integrating web-based and 3d learning environments: Second life meets moodle. *UPGRADE*, 9(3):8–14, 2008.
- [Mar11] D. Maroto, D. Leony, C. Delgado Kloos, M. B. Ibáñez, and J. J. García Rueda. Orchestrating learning activities in 3d virtual worlds: IMS-LD in open wonderland. In *Proceedings of the 6th European conference on Technology enhanced learning: towards ubiquitous learning*, EC-TEL 2011, pages 455–460, Palermo, Italy, September 2011.
- [Mar12] J. A. Marcos. *Análisis de interacciones para la detección dinámica y el soporte de roles participativos en entornos CSCL aplicando técnicas de análisis SNA*. Phd thesis, University of Valladolid, Spain, 2012.
- [MC12a] J. A. Muñoz-Cristóbal, J. I. Asensio-Pérez, L. P. Prieto, I. M. Jorrín-Abellán, Y. Dimitriadis, and A. Martínez-Monés. Helping educators to deploy CSCL scripts into mainstream VLEs that integrate third-party web and augmented reality tools. In *Workshop on Digital Ecosystems for Collaborative Learning, in conjunction with International Conference of the Learning Sciences (ICLS 2012)*, Sydney, Australia, July 2012.
- [MC12b] J. A. Muñoz-Cristóbal, L. P. Prieto, J. I. Asensio-Pérez, I. M. Jorrín-Abellán, and Y. Dimitriadis. Lost in translation from abstract learning design to ICT implementation: A study using Moodle for CSCL. In *Proceedings of the European Conference on Technology-Enhanced Learning 2012 (EC-TEL 2012)*, Saarbrücken, Germany, September 2012.
- [MC15] J. A. Muñoz-Cristóbal, J. I. Asensio-Pérez, A. Martínez-Monés, L. P. Prieto, I. M. Jorrín-Abellán, and Y. Dimitriadis. Bucket-server: A system for including teacher-controlled flexibility in the management of learning artifacts in across-spaces learning situations. In *Tenth European Conference on Technology Enhanced Learning (EC-TEL 2015)*, 2015. (Accepted for publication).
- [Mer02] S. B. Merriam. Introduction to qualitative research. In *Qualitative Research in Practice: Examples for Discussion and Analysis*, pages 3–17. Jossey-Bass, 2002.
- [Mik13] A. Mikroyannidis, A. Okada, P. Scott, E. Rusman, M. Specht, K. Stefanov, P. Boytchev, A. Protopsaltis, P. Held, S. Hetzner, K. Kikis-Papadakis, and F. Chaimala. weSPOT: A personal and social approach to inquiry-based learning. *Journal of Universal Computer Science*, 19(14):2093–2111, 2013.
- [Mil94] M. B. Miles and A. M. Huberman. *Qualitative Data Analysis. An Expanded Sourcebook*. SAGE Publications Inc, Thousand Oaks, CA, USA, 1994.

- [Mil13] M. Milrad, L.-H. Wong, M. Sharples, G.-J. Hwang, C.-K. Looi, and H. Ogata. Seamless learning: An international perspective on next-generation technology-enhanced learning. In Z. L. Berge and L. Y. Muilenburg, editors, *Handbook of Mobile Learning*, pages 95–108. Routledge, Abingdon, April/Spring 2013.
- [MM13] R. Martinez-Maldonado, Y. Dimitriadis, A. Clayphan, J. A. Muñoz-Cristóbal, J. Kay, L. P. Prieto-Santos, and M. J. Rodríguez-Triana. Integrating orchestration of ubiquitous and pervasive learning environments. In *Proceedings of the 25th Australian Computer-Human Interaction Conference: Augmentation, Application, Innovation, Collaboration (OzCHI '13)*, pages 189–192, Adelaide, Australia, November 2013.
- [Mor95] J. Morrison and J. F. George. Exploring the software engineering component in MIS research. *Communications of the ACM*, 38(7):80–91, 1995.
- [Mul12] P. Mulholland, S. Anastopoulou, T. Collins, M. Feisst, M. Gaved, L. Kerawalla, M. Paxton, E. Scanlon, M. Sharples, and M. Wright. nQuire: Technological support for personal inquiry learning. *IEEE Transactions on Learning Technologies*, 5(2):157–169, 2012.
- [Nir10] J. Niramitranon, M. Sharples, C. Greenhalgh, and C.-P. Lin. Orchestrating learning in a one-to-one technology classroom. In *6th IEEE International Conference on Wireless, Mobile and Ubiquitous Technologies in Education (WMUTE)*, pages 96–103, Kaohsiung, Taiwan, April 2010.
- [Nun90] J. F. Nunamaker, Jr., M. Chen, and T. D. M. Purdin. Systems development in information systems research. *Journal of Management Information Systems*, 7(3):89–106, 1990.
- [Orl91] W. J. Orlikowski and J. J. Baroudi. Studying information technology in organizations: Research approaches and assumptions. *Information Systems Research*, 2(1):1–28, 1991.
- [Pef07] K. Peffers, T. Tuunanen, M. Rothenberger, and S. Chatterjee. A design science research methodology for information systems research. *Journal of Management Information Systems*, 24(3):45–77, 2007.
- [Pop00] C. Pope, S. Ziebland, and N. Mays. Analysing qualitative data. *BMJ*, 320(7227):114–116, 2000.
- [Pou13] S. Pourmirza and M. Gardner. Integrating a facebook group with the open wonderland environment. In *3rd European Immersive Education Summit (EiED'13)*, pages 17–22, London, UK, November 2013.
- [Pri11] L. P. Prieto, M. H. Dlab, I. Gutiérrez, M. Abdulwahed, and W. Balid. Orchestrating technology enhanced learning: A literature review and a conceptual framework. *International Journal of Technology Enhanced Learning*, 3(6):583–598, 2011.
- [Pri12] L. P. Prieto. *Supporting orchestration of blended CSCL scenarios in Distributed Learning Environments*. Phd thesis, University of Valladolid, Spain, 2012.
- [Pri13a] L. P. Prieto, J. I. Asensio-Pérez, J. A. Muñoz-Cristóbal, Y. Dimitriadis, I. M. Jorrín-Abellán, and E. Gómez-Sánchez. Enabling teachers to deploy CSCL designs across

- multiple distributed learning environments. *Transactions on Learning Technologies*, 6(4):324–336, 2013.
- [Pri13b] L. P. Prieto, J. A. Muñoz-Cristóbal, Y. Dimitriadis, and J. I. Asensio-Pérez. Flexible CSCL scripting using paper, generic augmented reality browsers and GLUEPS-AR. In *Workshop on Human-Computer Interaction and the Learning Sciences, 10th International Conference on Computer Supported Collaborative Learning (CSCL 2013)*, University of Wisconsin - Madison, USA, June 2013.
- [Pri14a] L. P. Prieto, J. I. Asensio-Pérez, J. A. Muñoz-Cristóbal, I. M. Jorrín-Abellán, Y. Dimitriadis, and E. Gómez-Sánchez. Supporting orchestration of CSCL scenarios in web-based distributed learning environments. *Computers & Education*, 73:9–25, 2014.
- [Pri14b] L. P. Prieto, Y. Wen, D. Caballero, and P. Dillenbourg. Review of augmented paper systems in education: An orchestration perspective. *Journal of Educational Technology & Society*, 17(4):169–185, 2014.
- [PS11] M. Pérez-Sanagustín, G. Ramirez-Gonzalez, D. Hernández-Leo, M. Muñoz-Organero, P. Santos, J. Blat, and C. Delgado Kloos. Discovering the campus together: A mobile and computer-based learning experience. *Journal of Network and Computer Applications*, 35(1):167–188, January 2011.
- [Rak08] R. Rakshit and Y. Ogneva-Himmelberger. Application of virtual globes in education. *Geography Compass*, 2(6):1995–2010, 2008.
- [RC13] A. Ruiz-Calleja. *SEEK-AT-WD: A social-semantic infrastructure for educators to discover and select ICT tools in the Web of Data*. Phd thesis, University of Valladolid, Spain, 2013.
- [Ros13] J. Roschelle, Y. Dimitriadis, and U. Hoppe. Classroom orchestration: Synthesis. *Computers & Education*, 69:523–526, 2013.
- [RT14] M. J. Rodríguez-Triana. *Linking scripting & monitoring support in blended CSCL scenarios*. Phd thesis, University of Valladolid, Spain, 2014.
- [San11] P. Santos, M. Pérez-Sanagustín, D. Hernández-Leo, and J. Blat. QuesTInSitu: From tests to routes for assessment in situ activities. *Computers & Education*, 57(4):2517–2534, 2011.
- [Sat01] M. Satyanarayanan. Pervasive computing: Vision and challenges. *IEEE Personal Communications*, 8(4):10–17, 2001.
- [Sha09] M. Sharples, I. A. Sanchez, M. Milrad, and G. Vavoula. Mobile learning: small devices, big issues. In N. Balacheff, S. Ludvigsen, T. de Jong, and S. Barnes, editors, *Technology Enhanced Learning: Principles and Products*, pages 233–249. Springer, Heidelberg, Germany, 2009.
- [Sha13] M. Sharples. Shared orchestration within and beyond the classroom. *Computers & Education*, 69:504–506, 2013.

- [She04] A. K. Shenton. Strategies for ensuring trustworthiness in qualitative research projects. *Education for Information*, 22(2):63–75, 2004.
- [Spi10] D. Spikol and J. Eliasson. Lessons from designing geometry learning activities that combine mobile and 3d tools. In *6th IEEE International Conference on Wireless, Mobile and Ubiquitous Technologies in Education (WMUTE), 2010*, pages 137–141, April 2010.
- [Sta95] R. E. Stake. *The Art of Case Study Research*. SAGE Publications Inc, Thousand Oaks, CA, USA, 1995.
- [Sta04] R. E. Stake. *Standards-Based and Responsive Evaluation*. SAGE Publications Inc, Thousand Oaks, CA, USA, 2004.
- [Sut12] R. Sutherland, S. Eagle, and M. Joubert. A vision and strategy for technology enhanced learning: Report from the STELLAR network of excellence. Report, STELLAR, 2012.
- [Syv05] A. Syvanen, R. Beale, M. Sharples, M. Ahonen, and P. Lonsdale. Supporting pervasive learning environments: Adaptability and context awareness in mobile learning. In *IEEE International Workshop on Wireless and Mobile Technologies in Education, WMTE '05*, pages 251–253, 2005.
- [Tch13] P. Tchounikine. Clarifying design for orchestration: Orchestration and orchestrable technology, scripting and conducting. *Computers & Education*, 69:500–503, 2013.
- [Ter12] S. Ternier, R. Klemke, M. Kalz, P. van Ulzen, and M. Specht. ARLearn: Augmented reality meets augmented virtuality. *Journal of Universal Computer Science, Special Issue on Technology for learning across physical and virtual spaces*, 18(15):2143–2164, 2012.
- [Tho05] S. Thomas. Pervasive, persuasive elearning: Modeling the pervasive learning space. In *Third IEEE International Conference on Pervasive Computing and Communications Workshops, PerCom 2005 Workshops*, pages 332–336, 2005.
- [W3C09] W3C. Xforms 1.1. W3C Recommendation, October 2009.
- [Wan05] F. Wang and M. J. Hannafin. Design-based research and technology-enhanced learning environments. *Educational Technology Research and Development*, 53(4):5–23, 2005.
- [War09] S. Warburton. Second life in higher education: Assessing the potential for and the barriers to deploying virtual worlds in learning and teaching. *British Journal of Educational Technology*, 40(3):414–426, 2009.
- [Wei91] M. Weiser. The computer for the 21st century. *Scientific American*, 265:94–104, 1991.
- [Wil95] B. G. Wilson. Metaphors for instruction: Why we talk about learning environments. *Educational Technology*, 35(5):25–30, 1995.
- [Won11] L.-H. Wong and C.-K. Looi. What seams do we remove in mobile-assisted seamless learning? a critical review of the literature. *Computers & Education*, 57(4):2364–2381, 2011.

-
- [Woo10] B. P. Woolf. A roadmap for education technology. Report of results on NSF sponsored workshops, 2010.
- [Wu13] H.-K. Wu, S. W.-Y. Lee, H.-Y. Chang, and J.-C. Liang. Current status, opportunities and challenges of augmented reality in education. *Computers & Education*, 62:41–49, 2013.
- [Yin81] R. K. Yin. The case study crisis: Some answers. *Administrative Science Quarterly*, 26(1):58–65, 1981.
- [Zur14] G. Zurita, N. Baloian, and J. Frez. Using the cloud to develop applications supporting geo-collaborative situated learning. *Future Generation Computer Systems*, 34:124–137, 2014. Special Section: Distributed Solutions for Ubiquitous Computing and Ambient Intelligence.

Appendices

Appendix A

Deploying learning designs across physical and web spaces: learning design

This appendix includes the learning design mentioned in Chapter 2, which was co-designed by a teacher and the evaluation team involved in such study. The learning design was not included in the corresponding publication due to space restrictions. The learning design consists of a set of various inter-related learning situations, composed by multiple activities which involve different physical and virtual spaces. The learning design presented here is the final version that was eventually deployed in Moodle (translated to english). In addition to such design, this appendix also includes how the design was structured to be deployed in Moodle by means of GLUEPS-AR. Thus, the design was divided into three learning situations, which was deployed in Moodle independently (as described in Chapter 2).

Orienteering in the natural environment in three steps: Classroom, campus and Cervera de Pisuerga (urban and natural)











28/11/2012

Summary















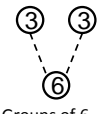



Educational scenario proposed for a course on Physical Education on the Natural Environment, of the 4th year (out of 4) of the undergraduate degree in Primary Education. The scenario is based on real learning situations carried out by the teachers of the University of Valladolid in such course. The scenario consists of a series of orienteering activities, which is one of the main groups of contents of the subject, in which the students learn how to orient themselves in different physical locations. The complexity increases over the activities, starting with activities in a classroom, continuing in the campus of the university... Finally, a learning situation is conducted in the rural and natural environment of Cervera de Pisuerga, a little town in the Palencia mountains, a space relatively nearby the mentioned university. In this practice the students work with maps of different kinds and scales.

- ✓ **Course:** Physical Education in the Natural Environment. 4th course of the undergraduate degree in Primary Education.
- ✓ **Objectives:**
 - ❑ To create sequenced proposals around the different uses of the orienteering activities, from a educational perspective.
 - ❑ To learn how to manage in the natural environment.
 - ❑ To develop skills regarding the interpretation of maps, the use of a compass, and orienteering techniques.
 - ❑ To enable the adaptation of the orienteering activities to the nearby environment, and to our contextual possibilities.
 - ❑ To know the natural environment of Cervera, and the integration between the rural core and its natural surroundings.
 - ❑ To obtain intellectual, emotional and social skills, solving little problems
- ✓ **Spaces:**
 - ❑ 3 different physical contexts, with remote activities between them.
 - Classroom
 - Campus
 - Cervera de Pisuerga
 - ❑ Moodle is used as online campus, and as central system for the structuring of the activities. There is a global forum in the course.
- ✓ **Number of students:** 18









Legend

-  *Compass and map. When the compass appears over a resource, it indicates that the resource is geopositioned.*
-  *Web documents and videos*
-  *Google Docs*
-  *Mobile device*
-  *QR code*
-  *Augmented Reality (AR) marker. Using Junaio (an AR app), the marker is "linked" with virtual artifacts, such as web pages.*
-  *Google Forms*
-  *Moodle virtual campus*
-  *Mobile AR app*
-  *Google Presentations*









Sequence of activities

Session	Duration (h)	Tools	Activity description	Teacher tasks	Grouping
1 Classroom	4 F2F + 0,5 R	   	<p>1.1 In the Moodle course there is basic information about cartography, orienteering, etc., which the students have to read. The teacher lectures regarding the use of the map and the compass</p>	Explanation of orienteering techniques	Individual ①
			<p>1.2 Each student has to draw a sketch map of the classroom, using Google Presentations.</p>	Support to the students	①
			<p>1.3 Now the pyramid pattern is followed. The students set up groups of 3, and afterwards , groups of 6 combining 2 groups of 3.</p> <ul style="list-style-type: none"> In the group of 3 they have to create a report, selecting the 20 recommendations they would give to a student in order to learn how to orient. They have to reach an agreement about the sketch map of the classroom. In the group of 6, they have to reach an agreement about the sketch map of the classroom, and upload the agreed sketch map to Moodle. In groups of 6, a group has to “unmake” the classroom, and another group has to “make” it following the sketch map, and so on. Finally, each group of 6 has to reach an agreement of 20 recommendations. 	Organization of groups. Support to the students	Groups of 3  Groups of 6
			<p>1.4 The teacher extracts questions from the recommendations of the groups, and puts them (copy/paste) in Google Docs positioned virtually (by means of AR) in the campus. They will be used in the activity 3.</p>	Extract questions from the students' works and put them in Google Docs (which have been created automatically)	
2 Campus	6 F2F + 2 R	    	<p>2.1 The students, in groups of 3, have to go to the Campus, to a position indicated in Moodle. The Campus is divided into three areas (they don't know it). Each area is assigned to two groups. They have instructions in such position, in a document geopositioned with AR: they have to draw a sketch map of that area in a paper in a specific time. They have to upload the result to a Google Docs (taking a picture and uploading it, or pasting a link to the location of the picture (in Google Docs, dropbox, etc.)</p>	Explanation of the activity, organization of groups, support to the students, management of the activity	
			<p>2.2 After a time, the teacher geoposition the Google Docs in which each group has represented their map. Each group can see the map of another group that has covered the same area. Thus, each group has to find errors, indicating them in the same Google Docs, adding the reasons they think caused such errors</p>	Activation (with a click) of the visibility of the corresponding documents in Junao. Management of the activity	
			<p>2.3 Both groups join, and create a unique sketch map of the area. The result is included in a Google Docs (taking a picture and pasting it or a link to the picture in dropbox, etc.)</p>	Support to the students	
			<p>2.4 Groups of 3 students are set up, composed of a student from each area. Each group creates a map of the complete campus, using the three previous maps. They have to upload the map to Moodle</p>	Explanation of the activity, support to the students. Review of works	
			<p>2.5 The teacher explains how a cartographer would solve what they did with a progressively collaborative sketch map, and he uploads such material to Moodle, to may be consulted.</p>	Explanation	
3 Campus	5 FTF	   	<p>3.1 In groups of 3, the students design, in a Google Presentations, orienteering routes in the campus, depending on different parameters: difficulty, length, etc.</p>	Explanation of the activity, support to the students. Review of works	③
			<p>3.2 The previous groups, in the campus, have to put QR codes as orienteering markers, following the designed routes, using the paper map of the previous activity</p>	Support to the students	③
			<p>3.3 The groups of 3 follow the routes created in the previous activity. With a QR code reader, they can access the documents of the activity 1.4, with the questions posed by the teacher. The students set up groups of 3 and follow the routes, answering the questions of the documents. The teacher knows if someone was in a marker looking at the answers. Different strategies can be followed to find the markers and follow different routes, to practice multiple orienteering skills..</p>	Explanation of the activity, support to the students. Previously, selection of locations	③

Sequence of activities

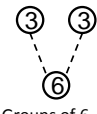
Session	Duration (h)	Tools	Activity description	Teacher tasks	Grouping
4 <i>Online</i>	4 R		4.1 (Jigsaw – individual phase) Cervera is divided into three topics: 1) physical activities that can be conducted in the environment, 2) natural values of the environment, 3) ethnography and culture of the environment. There is basic documentation about such topics (or link to documentation) available in Moodle. The students read the topic that they have assigned according to the next activity.	Explanation of the activity, support to the students.	①
		 	4.2 (Jigsaw – expert phase) There are 3 experts' groups of 6 people. Each group has to create a report about an assigned topic. They can use a Google Docs and a Moodle forum. The Google Docs are geopositioned automatically in Cervera, close to the locations that they will have to find in the activity 6.	Support to the students. Review of works	⑥ ⑥ 1 1
5 <i>Classroom</i>	2 F2F		5.1 (Jigsaw – jigsaw phase) 6 groups of 3 students are set up (with a student from each experts' group). Each group has to create a presentation about the rural and natural environment of Cervera, and present it to the rest of the class	Explanation of the activity, support to the students.	③
6 <i>Cervera</i>	4 F2F	    	6.1 (Jigsaw – jigsaw phase) The students, in groups of 3, have to find locations corresponding with one of the options: 1) given pictures of the area (without using a map); 2) positions marked in a map. Around each location, as a clue, the documents created in the activity 4.2 regarding the topic of interest of the location are geopositioned. Also, other documents related to the environment (videos, audios, clues, etc.) can be geopositioned by the teacher. Once they reach the location, they find a marker linked to a questionnaire regarding the corresponding topic. They have to answer it. In a same marker, the questionnaires can be the same or different for the different groups.	Explanation of the activity, setting up of markers in Cervera, support to the students. Previously: selection of locations/pictures and preparation of documentation	③







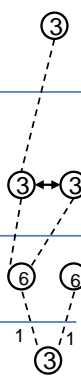

Deployment using GLUEPS-AR (1)

Session	Duration (h)	Tools	Activity description	Teacher tasks	Grouping
1 Classroom	4 F2F + 0,5 R	    	<p>1.1 In the Moodle course there is basic information about cartography, orienteering, etc., which the students have to read. The teacher lectures regarding the use of the map and the compass</p>	Explanation of orienteering techniques	Individual ①
			<p>1.2 Each student has to draw a sketch map of the classroom, using Google Presentations.</p>	Support to the students	①
			<p>1.3 Now the pyramid pattern is followed. The students set up groups of 3, and afterwards, groups of 6 combining 2 groups of 3.</p> <ul style="list-style-type: none"> In the group of 3 they have to create a report, selecting the 20 recommendations they would give to a student in order to learn how to orient. They have to reach an agreement about the sketch map of the classroom. In the group of 6, they have to reach an agreement about the sketch map of the classroom, and upload the agreed sketch map to Moodle. In groups of 6, a group has to “unmake” the classroom, and another group has to “make” it following the sketch map, and so on. Finally, each group of 6 has to reach an agreement of 20 recommendations. 	Organization of groups. Support to the students	Groups of 3  Groups of 6
			<p>1.4 The teacher extracts questions from the recommendations of the groups, and puts them (copy/paste) in Google Docs positioned virtually (by means of AR) in the campus. They will be used in the activity 3.</p>	Extract questions from the students' works and put them in Google Docs (which have been created automatically)	
3 Campus	5 FTF	   	<p>3.1 In groups of 3, the students design, in a Google Presentations, orienteering routes in the campus, depending on different parameters: difficulty, length, etc.</p>	Explanation of the activity, support to the students. Review of works	③
			<p>3.2 The previous groups, in the campus, have to put QR codes as orienteering markers, following the designed routes, using the paper map of the previous activity</p>	Support to the students	③
			<p>3.3 The groups of 3 follow the routes created in the previous activity. With a QR code reader, they can access the documents of the activity 1.4, with the questions posed by the teacher. The students set up groups of 3 and follow the routes, answering the questions of the documents. The teacher knows if someone was in a marker looking at the answers. Different strategies can be followed to find the markers and follow different routes, to practice multiple orienteering skills..</p>	Explanation of the activity, support to the students. Previously, selection of locations	③

Deployment using GLUEPS-AR (2)

Session	Duration (h)	Tools	Activity description	Teacher tasks	Grouping
2	6 F2F + 2 R		<p>2.1 The students, in groups of 3, have to go to the Campus, to a position indicated in Moodle. The Campus is divided into three areas (they don't know it). Each area is assigned to two groups. They have instructions in such position, in a document geopositioned with AR: they have to draw a sketch map of that area in a paper in a specific time. They have to upload the result to a Google Docs (taking a picture and uploading it, or pasting a link to the location of the picture (in Google Docs, dropbox, etc.)</p> <p>2.2 After a time, the teacher geoposition the Google Docs in which each group has represented their map. Each group can see the map of another group that has covered the same area. Thus, each group has to find errors, indicating them in the same Google Docs, adding the reasons they think caused such errors</p> <p>2.3 Both groups join, and create a unique sketch map of the area. The result is included in a Google Docs (taking a picture and pasting it or a link to the picture in dropbox, etc.)</p> <p>2.4 Groups of 3 students are set up, composed of a student from each area. Each group creates a map of the complete campus, using the three previous maps. They have to upload the map to Moodle</p> <p>2.5 The teacher explains how a cartographer would solve what they did with a progressively collaborative sketch map, and he uploads such material to Moodle, to may be consulted.</p>	<p>Explanation of the activity, organization of groups, support to the students, management of the activity</p> <p>Activation (with a click) of the visibility of the corresponding documents in Juniao. Management of the activity</p> <p>Support to the students</p> <p>Explanation of the activity, support to the students. Review of works</p> <p>Explanation</p>	

Deployment using GLUEPS-AR (3)

Session	Duration (h)	Tools	Activity description	Teacher tasks	Grouping
4 Online	4 R	  	<p>4.1 (Jigsaw – individual phase) Cervera is divided into three topics: 1) physical activities that can be conducted in the environment, 2) natural values of the environment, 3) ethnography and culture of the environment. There is basic documentation about such topics (or link to documentation) available in Moodle. The students read the topic that they have assigned according to the next activity.</p>	Explanation of the activity, support to the students.	①
			<p>4.2 (Jigsaw – expert phase) There are 3 experts' groups of 6 people. Each group has to create a report about an assigned topic. They can use a Google Docs and a Moodle forum. The Google Docs are geopositioned automatically in Cervera, close to the locations that they will have to find in the activity 6.</p>	Support to the students. Review of works	⑥ ⑥ 1 1
5 Classroom	2 F2F		<p>5.1 (Jigsaw – jigsaw phase) 6 groups of 3 students are set up (with a student from each experts' group). Each group has to create a presentation about the rural and natural environment of Cervera, and present it to the rest of the class</p>	Explanation of the activity, support to the students.	③
6 Cervera	4 F2F	   	<p>6.1 (Jigsaw – jigsaw phase) The students, in groups of 3, have to find locations corresponding with one of the options: 1) given pictures of the area (without using a map); 2) positions marked in a map. Around each location, as a clue, the documents created in the activity 4.2 regarding the topic of interest of the location are geopositioned. Also, other documents related to the environment (videos, audios, clues, etc.) can be geopositioned by the teacher. Once they reach the location, they find a marker linked to a questionnaire regarding the corresponding topic. They have to answer it. In a same marker, the questionnaires can be the same or different for the different groups.</p>	Explanation of the activity, setting up of markers in Cervera, support to the students. Previously: selection of locations/pictures and preparation of documentation	③

Appendix B

APIs, contracts and source code of GLUEPS-AR and Bucket-Server

This appendix describes the different APIs offered by the two systems proposed in the thesis: GLUEPS-AR and the Bucket-Server. This appendix also includes the contracts that the different adapters should implement to be integrated with the corresponding manager component (GLUEPS-AR manager or Bucket-Server manager). In addition, the source code of GLUEPS-AR can be retrieved from <https://www.gsic.uva.es/gluepsar/>, and the source code of the Bucket-Server from <https://www.gsic.uva.es/buckets/> (last access April 2015).

1. GLUEPS-AR

Table B.1: Resources of the GLUEPS-AR API inherited from GLUE!-PS, as well as methods and operations allowed (see [Pri12])

Resource	Methods	Operation and response
/designs	GET POST DELETE	Creation, retrieval, and deletion of learning designs. Accepts diverse formats and Learning Design (LD) languages for creation. Responds with XML data on retrieval.
/deploys	GET POST PUT DELETE	Creation, retrieval, update and deletion of particularized learning designs to be deployed/managed. Accepts diverse formats for creation. Responds with XML data on retrieval
/learningEnvironments	GET	Retrieval of the available learning platform installations in which GLUEPS-AR can deploy and manage designs. Responds with XML data including information about the courses and tools available, both built-in and external.
/learningEnvironments/{learningEnvironmentId}/tools/{toolId}/configuration	GET	Retrieval of information about the configuration data needed to create instances of built-in and external tools available in a certain Ubiquitous Learning Environment (ULE). Responds with XForms [W3C09] data.
/learningEnvironments/{learningEnvironmentId}/courses/{courseId}	GET	Retrieval of users (e.g. students) available in a certain learning platform installation and course. Responds with XML data.
/deploys/{deployId}/toolInstances	GET POST DELETE	Creation, retrieval, and deletion of individual (built-in or external) tool instances that are used in a particularization of a learning design.
/deploys/{deployId}/live	GET PUT DELETE	Deployment, re-deployment and un-deployment of a particularized learning design across a concrete ULE that supports dynamic deployments. Performs the deployment/redeployment/undeployment through the Learning Environment (LE) adapter (AR adapter, VLE adapter, VG adapter) and responds with a reference to the location of the deployed/updated particularized learning design in the learning platform.
/deploys/{deployId}/static	GET PUT DELETE	Deployment, re-deployment and un-deployment of a particularized learning design across a concrete ULE that supports static deployments. Responds with a static representation of the deployed/updated particularized learning design.

Table B.2: Contract for GLUEPS-AR Learning Environment adapters (inherited from GLUE!-PS).

Resource	Methods	Operation and response
/deploy	POST DELETE	(Optional) Creation and deletion of courses in the LE
/le-courses	GET	(Optional) Retrieval of the list of courses of the LE. Answers with a XML with the list of courses
/le-courses/{le-courseId}/le-users	GET	(Optional) Retrieval of the list of users of a LE. Answers with a XML with the list of users

Table B.3: Contract for GLUEPS-AR Tool adapters (inherited from GLUE!-PS).

Resource	Methods	Operation and response
/configuration	GET	Retrieval of the configuration form of an artifact type. Answers with a XForms with the configuration form
/artifact	GET POST PUT DELETE	Retrieval, creation, update and deletion of remote artifacts. Responds with XML data on retrieval

Table B.4: Rest of the resources, methods and operations of the GLUEPS-AR API.

Resource	Method	Content	Operation and response
/deploys	GET	username, PositionTypes	Retrieval of the list of deploys in which a user is participant. Answers a JSON [Ecm13] with the list of deploys filtered by username and positionTypes
/deploys/{deployId}/artifacts	GET	username, positionType, position, maxArtifacts, useMaxdistance	Retrieval of the list of artifacts. Answers a JSON with the list of artifacts
/deploys/{deployId}/users	GET	state	Retrieval of the list of logged/active users in a deploy. Answers a JSON with the list of logged/active users in the deploy
/deploys/{deployId}/users	POST	deviceId, username, deployId, leType, positionType, position, orientation	Creation of a new one logged/active user in the deploy. Answers the URI of the logged/active user
/deploys/{deployId}/users/{userId}	GET		Retrieval of the representation of a logged/active user. Answers a JSON representation of the user
/deploys/{deployId}/users/{userId}	PUT	deviceId, username, deployId, leType, positionType, position, orientation	Update of a logged/active user. Returns the JSON representation of the user
/deploys/{deployId}/users/{userId}	DELETE		Deletion of a logged/active user. Returns OK
/events	GET	deviceId, username, deployId, leType, positionType, position, orientation, action, remoteIpAddress, artifactId, artifactName	Retrieval of a list of events. Answers a JSON with the list
/events	POST	deviceId, username, deployId, leType, positionType, position, orientation, action, remoteIpAddress, artifactId, artifactName	Creation of a new event. Returns OK

Table B.5: Recommended API in GLUEPS-AR Learning Environment adapter (AR-adapter, VLE-adapter, VG-adapter) for being used by Learning Environments.

Resource	Methods	Operation and response
/appType/{operation}/{deployId}/{username}/{options}	GET POST PUT DELETE	Different operations and answers

2. Bucket-Server

Table B.6: Bucket-Server API resources, as well as methods and operations allowed.

Resource	Method	Content	Operation and response
/artifactTypes	GET		Retrieval of the list of available artifacts types. Answers a JSON with a list of artifacts types (ID-Name)
/artifactTypes/{artifactType}/configuration	GET		Retrieval of the configuration form for the artifact type. Answers a XForms with the configuration form
/buckets	GET	username, positionTypes	Retrieval of the list of buckets. Answers a JSON with a list of buckets filtered by username and positionTypes

/buckets	POST	name, description, bPosition, bPosition-Type, bMaxDistance, maxartifacts, edition-Type, positionType, artifactsTypes, author, users	Creation of a bucket. Returns the URI of the bucket resource
/buckets/{bucketId}	GET	username, position, view	Retrieval of the representation of a bucket. The answer depends on the content-type requested: -text/html: HTML representation of the bucket (including list of artifacts) -application/json: JSON representation of the bucket (including list of artifacts)
/buckets/{bucketId}	PUT	name, description, maxartifacts, edition-Type, positionType, artifactsTypes, author, users	Update of the configuration of a bucket (artifacts are not modified). Returns the URI of the bucket resource
/buckets/{bucketId}	DELETE		Deletion of the bucket (and its artifacts). Returns OK
/buckets/{bucketId}/artifacts	GET	username, position, positionType, maxArtifacts, useMaxdistance	Retrieval of the list of artifacts. Answers a JSON with a list of artifacts filtered by the attributes of the request
/buckets/{bucketId}/artifacts	POST	name, description, type, position, maxdistance, positionType, scale, orientation, username	Creation of an artifact in the bucket. Answers the URI of the artifact resource
/buckets/{bucketId}/artifacts/{artifactId}	GET	username	Retrieval of the representation of the corresponding artifact. Answers the JSON representation of the corresponding artifact
/buckets/{bucketId}/artifacts/{artifactId}	PUT	name, description, type, position, maxdistance, positionType, scale, orientation, username	Update of the local configuration of an artifact (remote tool instance or resource remains intact). Returns the URI of the artifact resource
/buckets/{bucketId}/artifacts/{artifactId}	DELETE		Deletion of the artifact and the corresponding tool instance/resource. Returns OK
/buckets/{bucketId}/artifacts/{artifactId}/toolInstance	GET	URL options, username	Retrieval of the final (remote) tool instance or resource. Returns a redirection (e.g., HTTP status code 301) to the final (remote) tool instance or resource
/buckets/{bucketId}/artifacts/{artifactId}/toolInstance	POST	Multipart: tool XForm, file, username	Creation of the remote tool instance or resource. Returns the URL of the resource/tool instance (if a DLE adapter is used, such a GLUE!, this URL is the URL provided by this DLE adapter).
/buckets/{bucketId}/artifacts/{artifactId}/toolInstance	PUT	Multipart: tool XForm, file, username	Update of the remote tool instance or resource. Returns the URL of the resource/tool instance (if a DLE adapter is used, such a GLUE!, this URL is the URL provided by this DLE adapter).
/buckets/{bucketId}/artifacts/{artifactId}/toolInstance	DELETE		Deletion of the final (remote) tool instance. Returns OK
/events	GET	appType, action, bucketId, username, deviceId, position, artifactId	Retrieval of a list of events. Answers a JSON with a list of events filtered by the attributes of the request
/events	POST	appType, action, bucketId, username, deviceId, position, artifactId	Creation of a event. Returns OK

Table B.7: Contract for Bucket-Server Artifacts Provider adapters.

Resource	Method	Content	Operation and response
/configuration	GET	artifactType	Retrieval of the configuration form of an artifact type. Answers a XForms with the configuration form
/artifacts	POST	Multipart: [XForm, file, artifactType, username, users]	Creation of a remote artifact. Returns the URL of the remote artifact
/artifacts/{artifactId}	GET	URL options, username	Retrieval of the URL of a remote artifact. Returns the URL of the remote artifact
/artifacts/{artifactId}	PUT	Multipart: [XForm, file, artifactType, username, users]	Update of a remote artifact. Returns the URL of the remote artifact
/artifacts/{artifactId}	DELETE		Deletion of a remote artifact. Returns OK

Table B.8: Recommended API in Bucket-Server Application adapters for being used by applications.

Resource	Methods	Operation and response
/ {appType} / {operation} / {bucketId} / {username} / {options}	GET POST PUT DELETE	Different operations and answers

Appendix C

Evaluation questionnaires

This appendix includes general templates (translated to english) of the two questionnaires used during the different evaluation works in order to gather data from the informants: a web-based exploratory questionnaire regarding the use of the proposed systems (GLUEPS-AR and Bucket-Server), and a score sheet used in the different feature analyses carried out.

1. Questionnaire regarding the orchestration support of a system

The following is the general questionnaire template employed in the different pilot studies and evaluation studies of the thesis in order to gather data regarding the use of the proposals. The questionnaire is focused on different orchestration aspects. It is an exploratory questionnaire, not aimed to measure, find relations between data or obtain statistically significant results. Also, since it is a template, some questions were added, removed or modified to configure the questionnaire finally used in each study. Some of the questions may not apply to some of the evaluation studies.

Page 1: Introduction

Hello!

This questionnaire is aimed to gather data regarding your impressions about different aspects of the learning situation(s) you have carried out with the help of our system.

The data obtained will be used in a research that is being conducted currently by our research team, [research group goes here], which tries to help teachers, by using technology, carry out learning situations that involve multiple physical and virtual spaces. You can find more information in the next link [link to project goes here], or contact us whenever you want!

The questionnaire is long. We apologize for this fact, but your answers will be very relevant for the research (thank you very much!).

Page 2: Background

We start with some general questions about you.

*¹1. Name [Open ended]

*2. Age [Open ended]

*3. Male/Female [Male | Female]

*4. Academic level

-Maximum level of studies reached and field [Open ended]

-Level of studies currently in process and field [Open ended]

Now your experience as a teacher:

*5. Experience as a teacher (years) and educational level (Primary school, Secondary school, University, etc.) [Open ended]

*6. Experience as a teacher in learning situations involving multiple physical and virtual spaces (virtual learning environment, web tools, classroom, playground, street, natural environment, etc.), previous to the activities carried out with our systems (years and summary of the experience) [open ended]

*7. Use of collaborative learning in your classes

[Never | Almost never | Few times | Sometimes | A lot of times | Regularly]

*8. Now your experience with ICT (not necessarily as a teacher) in different environments:

[Never | Almost never | Few times | Sometimes | A lot of times | Regularly]

-General use of ICT

-Use of ICT in web spaces (wikis, Moodle, etc.)

-Use of ICT in physical spaces (classroom, playground, street, natural environment, etc.)

-Use of ICT in 3D virtual worlds

-Use of ICT in your classes

9. Comments and explanations [Open ended]

Page 3: Design

Now, we are going to ask you about the support provided by the system [system's name goes here] to design the activities (before and during them).

*10. Rate, please, your degree of agreement or disagreement with the following assertions:

[1. Strongly disagree | 2. Disagree | 3. Somewhat disagree | 4. Somewhat agree | 5. Agree | 6. Strongly agree | Don't know/No answer]

-The system restricted the design of the activities I was able to do.

-The system enhanced the possibilities of designing activities.

-I think that the learning design I carried out satisfied my pedagogical requirements.

-With the system, I was able to deploy (a) learning design(s) which involved multiple physical and virtual spaces (e.g., web VLE, 3D virtual world, classroom, playground, natural environment, etc.).

11. In case of disagreement with any of the previous assertions, please, explain briefly why [Open ended]

*12. Rate, please, your degree of agreement or disagreement with the following assertion:

[1. Strongly disagree | 2. Disagree | 3. Somewhat disagree | 4. Somewhat agree | 5. Agree | 6. Strongly agree | Don't know/No answer]

-I would have been able to carry out the learning situation(s) designed without the system

13. If you would have been able to carry out the learning situation without the system, explain, please, briefly your answer, and also if you think that our system provided (or not) any benefit. [Open ended]

¹Questions marked with "*" are mandatory.

*14. What was the added value of the learning design conducted this year, in comparison with the learning situation carried out the previous years? [Open ended]

15. Comments and explanations [Open ended]

Page 4: Management

Now, we would like to know to what extent our system [system's name goes here] helped you manage the learning situation.

*16. Rate, please, your degree of agreement or disagreement with the following assertions:

[1. Strongly disagree | 2. Disagree | 3. Somewhat disagree | 4. Somewhat agree | 5. Agree | 6. Strongly agree | Don't know/No answer]

- I think the system helped me manage the learning situation from its design to its enactment.
- I think the system helped me manage the groups of students.
- I think the system helped me manage the learning tools and artifacts.
- I think the system allowed that the time devoted to the learning situation by me and by the students was efficient.

*17. How long did it take you to deploy the learning situation? (time using the system until the implementation in the learning environment was finished) (please, indicate the unit of time used in your explanation). [Open ended]

*18. Rate, please, your degree of agreement or disagreement with the following assertion:

[1. Strongly disagree | 2. Disagree | 3. Somewhat disagree | 4. Somewhat agree | 5. Agree | 6. Strongly agree | Don't know/No answer]

- I think the time devoted to the deployment using the system is affordable.

19. Comments and explanations [Open ended]

Page 5: Adaptation

Now we are going to ask you regarding how our system [system's name goes here] enables the modification of the learning design before the enactment, as well as how it enables the adaptation of the design when facing unexpected events during the enactment.

*20. Rate, please, your degree of agreement or disagreement with the following assertions:

[1. Strongly disagree | 2. Disagree | 3. Somewhat disagree | 4. Somewhat agree | 5. Agree | 6. Strongly agree | Don't know/No answer]

- I think the system enables changes in the learning design before, during and after the enactment.
- I think the system enables unexpected changes in the learning design during the enactment (e.g., changes in the accessibility or positioning of artifacts in the different spaces, changes in groups, etc.).
- I consider that enabling such changes is useful.
- I had to make changes in the learning design using the system [system's name goes here] (in the activities, groups of students, artifacts, etc.).
- I think that the system provided a good support to such changes.

*21. I wanted to change something that was not possible with the system [Yes | No]

22. If the previous answer is "Yes", please explain what did you want to change and you couldn't. [Open ended]

23. Comments and explanations [Open ended]

Page 6: Awareness

Now some questions regarding how you assessed the learning situation.

*24. How did you evaluate the students in these activities? [Open ended]

*25. What information did you use during the activities to be aware about what the students WERE DOING DURING the enactment? [Open ended]

*26. What information did you use after the end of the activities to be aware about what the students HAD DONE in the enactment? [Open ended]

27. If you wanted to know some information about what the students were doing, or had done, and the system did not provide you such information, please, explain it. [Open ended]

*28. Please, explain what elements (if any) have you missed in order to assess the students in the learning situation carried out. [Open ended]

Now, some questions to know your opinion regarding how the system [system's name goes here] enabled you to be aware of what it was happening or has happened.

*29. Rate, please, your degree of agreement or disagreement with the following assertions:

[1. Strongly disagree | 2. Disagree | 3. Somewhat disagree | 4. Somewhat agree | 5. Agree | 6. Strongly agree | Don't know/No answer]

-I think the system helped me assess the students in the activities.

-I think the system enabled me to know DURING the enactment what the students WERE DOING in activities conducted in VIRTUAL SPACES (such as VLE, Moodle, Google Earth, etc.).

-I think the system enabled me to know DURING the enactment what the students WERE DOING in activities conducted in PHYSICAL SPACES (such as classroom, playground, natural environment, etc.).

-I think the system enabled me to know AFTER THE END OF THE ACTIVITIES what the students HAD DONE in activities conducted in VIRTUAL SPACES (such as VLE, Moodle, Google Earth, etc.).

-I think the system enabled me to know AFTER THE END OF THE ACTIVITIES what the students HAD DONE in activities conducted in PHYSICAL SPACES (such as classroom, playground, natural environment, etc.).

-I think the information provided by the system to be aware of the students' actions is enough.

-I think the information provided by the system to be aware of the students' actions is presented in a format that is easy to understand.

30. Comments and explanations [Open ended]

Page 7: Roles of the teachers and other actors

Now we would like to know your opinion regarding how the [system's name goes here] system supports the different involved actors.

*31. Rate, please, your degree of agreement or disagreement with the following assertions:

[1. Strongly disagree | 2. Disagree | 3. Somewhat disagree | 4. Somewhat agree | 5. Agree | 6. Strongly agree | Don't know/No answer]

-I think the system enables the transference of part of the teacher's management load to the students (e.g., to take decisions regarding learning artifacts, or performing operations with artifacts, such as creating or modifying them).

-I think the system allows a certain degree of self-regulation to the students.

-I think the system can allow that the students take some decisions about the learning artifacts (e.g., what type of artifacts to use, or when/where create/access artifacts).

-I think the system can allow to give responsibility to the students (by enabling them to take decisions about learning artifacts). -I think giving responsibility to the students is relevant.

32. Comments and explanations [Open ended]

Page 8: Pragmatism

Now we ask you regarding the pragmatic use of the [system's name goes here] system in the educational practice.

From your experience using the [system's name goes here] system, we would like to know what is your general opinion about it and its possibilities, i.e., its range of applicability

*33. Rate, please, your degree of agreement/disagreement with the following assertions:

[1. Strongly disagree | 2. Disagree | 3. Somewhat disagree | 4. Somewhat agree | 5. Agree | 6. Strongly agree | Don't know/No answer]

- I think that the system can enable the carrying out of a wide range of learning activities.
- I think that the system can enable the carrying out of learning activities in different social levels (e.g., individual, group, class).
- I think that the system can enable the carrying out of learning activities in different spaces (web, VLE, classroom, playground, natural environment, 3D virtual world, etc.).
- I think that the system can enable the carrying out of learning activities which use different types of resources (text, images, pictures, drawing tools, etc.).
- I think that the system can enable the use of multiple pedagogical approaches, such as: collaborative learning, non-collaborative (traditional) learning, game-based learning, project-based learning, and others.
- I think that the system can enable the carrying out of multiple types of activities (e.g., different types of works in the classroom without AR, work with tablets, lecturing, work in the classroom with AR, field work with AR, etc.)

34. In case of disagreement with any of the previous assertions, please, explain briefly why [Open ended]

35. Any other comment or explanation regarding your answers [Open ended]

Now, other questions regarding the pragmatic use of the [system's name goes here] system

*36. Rate, please, your degree of agreement/disagreement with the following assertions:

[1. Strongly disagree | 2. Disagree | 3. Somewhat disagree | 4. Somewhat agree | 5. Agree | 6. Strongly agree | Don't know/No answer]

- I think the system fitted well with my necessities as a teacher.
- I think the system fitted well with the constraints of the involved educational institution.
- I think the system fitted well with the constraints of the involved educational context.
- I think the system is easy-to-use for non-ICT-experts teachers.
- I think the system is easy-to-use for non-ICT-experts students.
- I think the system is useful to be used in education.
- I would use again the system in my practice.

*37. If you would not use again the system in your practice, please, explain why. [Open ended]

*38. What was the role of the VLE? [Open ended]

*39. What was the role of the web tools (Google Docs, Picasa, etc.)? [Open ended]

*40. What was the role of the Virtual Earth Globes (Google Earth, Google Street View, etc.)? [Open ended]

*41. What was the role of the mobile AR apps (QR code readers, Junaio, Layar, etc.)? [Open ended]

*42. What was the added value of using such technologies? [Open ended]

*43. Rate, please, your degree of agreement/disagreement with the following assertions:

[1. Strongly disagree | 2. Disagree | 3. Somewhat disagree | 4. Somewhat agree | 5. Agree | 6. Strongly agree | Don't know/No answer]

- I think the system helped me integrate AR and Virtual Earth Globes with other tools and technologies that I used regularly in my classes the previous years (e.g., VLE, Web 2.0 tools, or others).
- Previously to know the [system's name goes here] system, I would have considered to use 3D virtual worlds in the learning situation.
- Previously to know the [system's name goes here] system, I would have considered to use AR in the

learning situation.

-I think the [system's name goes here] system enabled me to easily integrate AR and 3D virtual worlds in activities that I conducted previously without using such technologies.

-I think the [system's name goes here] system have moved 3D virtual worlds and AR closer to my educational practice.

-I think the system enabled me to include in the learning design multiple existing 3D virtual worlds and multiple AR apps.

-I would use 3D virtual worlds and AR again in my practice.

*44. Comment your impressions about using 3D virtual worlds and AR as you did. [Open ended]

*45. Comment what advantages and disadvantages do you consider of using 3D virtual worlds and/or AR in education. [Open ended]

46. Comments and explanations [Open ended]

Page 9: Alignment

Now some questions regarding the alignment of the different spaces, resources, and tools.

*47. Now, we ask you about the achievement of the learning goals, and the motivation of the students.

[1. Strongly disagree | 2. Disagree | 3. Somewhat disagree | 4. Somewhat agree | 5. Agree | 6. Strongly agree | Don't know/No answer]

-The learning goals initially defined were achieved.

-The learning situation helped achieve such goals.

-The [system's name goes here] system helped achieve such goals.

-The system helped in the motivation of the students.

*48. Rate, please, your degree of agreement/disagreement with the following assertions:

[1. Strongly disagree | 2. Disagree | 3. Somewhat disagree | 4. Somewhat agree | 5. Agree | 6. Strongly agree | Don't know/No answer]

-I think the system allows to take advantage of using multiple physical and virtual spaces.

-I think the system enables continuity between the activities conducted in different physical and virtual spaces (classroom, street, natural environment, VLE, 3D virtual world, etc.).

-I think the system has enabled the integration of the different physical and virtual spaces where the activities were conducted.

*49. Now, some questions regarding the use of mobile devices.

[1. Strongly disagree | 2. Disagree | 3. Somewhat disagree | 4. Somewhat agree | 5. Agree | 6. Strongly agree | Don't know/No answer]

-The system has enabled me to take advantage for learning of the mobility that mobiles devices afford.

-The system has enabled me to take advantage for learning of the social interaction that mobiles devices afford.

-The system has enabled me to take advantage for learning of the geopositioning and detection of markers (e.g., AR markers, QR codes) that mobiles devices afford.

50. Comments and explanations [Open ended]

Page 10: Theories

*51. Rate, please, your degree of agreement/disagreement with the following assertions:

[1. Strongly disagree | 2. Disagree | 3. Somewhat disagree | 4. Somewhat agree | 5. Agree | 6. Strongly agree | Don't know/No answer]

-The system enabled me to put into practice the pedagogical approaches that I wanted to use.

-I have organized the students' work in a similar manner than I used to do.

- The system has FORCED me to organize the students' work in a different manner than I used to do.
- The system has SUGGESTED me to organize the students' work in a different manner than I used to do.

52. If any of the last two answers were affirmative:

[1. Strongly disagree | 2. Disagree | 3. Somewhat disagree | 4. Somewhat agree | 5. Agree | 6. Strongly agree | Don't know/No answer]

- Changing the way I use organize the students' work has been useful.
- Changing the way I use organize the students' work required me an extra effort.

53. Comments and explanations [Open ended]

Page 11: Additional questions regarding the use of learning buckets

Finally, some additional questions regarding the "learning buckets".

Note: When we talk about "constraints", we mean the aspects that can be configured in a learning bucket to restrict what the students can do: artifacts types, maximum number of artifacts, edition type, positioning type.

*54. Rate, please, your degree of agreement/disagreement with the following assertions:

[1. Strongly disagree | 2. Disagree | 3. Somewhat disagree | 4. Somewhat agree | 5. Agree | 6. Strongly agree | Don't know/No answer]

- I understand what a learning bucket is, and for what I can use it.
- I think the constraints configurable in learning buckets allow to keep control about what is performed later on within them.
- I think such constraints are useful.

55. In case you consider any of the constraint as non-useful, please, explain which ones and why. [Open ended]

56. In case you consider useful other constraints that could be added to the learning bucket, please, say which ones and why. [Open ended]

*57. What properties do you consider interesting of the learning bucket? [Open ended]

*58. What advantages does the use of learning buckets have, in comparison with not using them? [Open ended]

59. Did you miss something in the learning buckets? [Open ended]

60. If you found any usability problem which should be solved in the learning buckets, please, explain it. [Open ended]

61. Comments and explanations [Open ended]

Now some questions regarding the use of both systems, GLUEPS-AR and Bucket-Server (using GLUEPS-AR or using learning buckets directly from within Moodle).

*62. Advantages and disadvantages that you consider of each of the two options. [Open ended]

*63. What of the two options do you prefer and why? [Open ended]

*64. What of the two options would you use and why? [Open ended]

2. Feature analysis Score sheet

The following is the questionnaire template used in the different feature analyses carried out in the thesis. We followed the DESMET methodology [Kit96] [Kit97] to perform a feature analysis, in which a group of assessors score the support provided by different systems to a set of features, using a questionnaire also known as score sheet.

Feature analysis Score Sheet

Assessed system:

Assessor:

Please, score the support provided by the system to the different features described, using the following judgment scale:

- 0. The system does not support the feature.
- 1. The system has a very little support of the feature. The system only supports the feature by means of extremely difficult operations, or radical modifications of the system.
- 2. The system has little support of the feature. The system only supports the feature by indirect means, or by means of not-standard configurations of such system.
- 3. The system has partial support of the feature. The system supposedly supports the feature, but some non-trivial aspect of the feature is not covered.
- 4. The system has strong support of the feature. The system supports the feature, but some trivial aspect of the feature is not covered.
- 5. The system has full support of the feature.

Feature	0.The system does not support the feature	1.The system has a very little support of the feature	2.The system has little support of the feature	3.The system has partial support of the feature	4.The system has strong support of the feature	5.The system has full support of the feature
Feature 1						
Feature 2						
Feature 3						
Feature 4						
Feature 5						
(...)						
Feature N						

Resumen

Apoyando al profesorado en la orquestación de situaciones de aprendizaje que ocurren a través de múltiples espacios físicos y virtuales

Resumen: El presente es un resumen en castellano del contexto general de la tesis, la metodología seguida, los objetivos definidos, los principales resultados conseguidos y las conclusiones más relevantes. La tesis doctoral trata sobre la orquestación de situaciones de aprendizaje “a través de espacios” (*across-spaces*, AS, en inglés): situaciones de aprendizaje que integran actividades que tienen lugar en múltiples espacios físicos y virtuales, y donde se da una transición suave, o continua, entre los distintos espacios. En particular, la tesis intenta proporcionar herramientas conceptuales y tecnológicas para apoyar a los docentes en la orquestación de este tipo de situaciones de aprendizaje, que puedan incluir espacios físicos, web y mundos virtuales 3D. Siguiendo la Metodología de Investigación de Desarrollo de Sistemas, y con un paradigma de investigación interpretativo subyacente, se proponen dos constructos (modelo de POI y noción de cubo de aprendizaje o *learning bucket*) y dos sistemas (GLUEPS-AR y Bucket-Server), para ayudar a los docentes en la orquestación de situaciones de aprendizaje AS. Para la evaluación de las propuestas, se realizaron múltiples análisis de características, estudios pilotos y estudios de evaluación, enmarcados en un modelo de evaluación “receptivo”.

1. Introducción

El aprendizaje no está restringido al espacio físico rodeado por las paredes del aula. El aprendizaje puede darse en múltiples espacios físicos y virtuales dentro y fuera del aula [Bru08] [Sha09]: Entornos Virtuales de Aprendizaje (VLEs, de las siglas en inglés) [Kel05], parques, museos, páginas web, mundos virtuales 3D (3DVWs, de las siglas en inglés), etc. Esta extensión de los espacios de aprendizaje más allá del aula ha sido estudiada por múltiples autores bajo distintas conceptualizaciones: aprendizaje móvil [Sha09], aprendizaje ubicuo [Bru08], aprendizaje “sin costuras” [Mil13] [Won11], aprendizaje “a través de espacios” [DK12], etc.

En todas estas concepciones, la tecnología es un factor clave para conseguir conectar los distintos espacios. Así, por ejemplo, tecnologías como los dispositivos móviles o la Realidad Aumentada² (AR, de las siglas en inglés) pueden ayudar a conectar los distintos espacios, y disminuir las discontinuidades entre ellos, de forma que se consiga una única entidad donde se pueda producir una experiencia continua de aprendizaje [Wu13]. Es lo que puede denominarse un entorno de aprendizaje ubicuo (ULE, de las siglas en inglés) [Jon04] [Li04]. Una situación

²La Realidad Aumentada es una tecnología que combina objetos virtuales y reales en un entorno real [Azu01].

de aprendizaje que se desarrolla en un ULE puede denominarse situación de aprendizaje a través de espacios (*across-spaces*, AS). Estas situaciones de aprendizajes que involucran múltiples espacios físicos y virtuales pueden beneficiarse del potencial educativo que tienen los distintos espacios. Así, por ejemplo, los espacios web (por ejemplo, usando VLEs), pueden hacer que los estudiantes sean participantes activos, además de permitir tanto educación presencial como a distancia [Dil02] [Kel05], los 3DVWs permiten la percepción de objetos desde múltiples perspectivas [Dal10] [Ded09], y los espacios físicos ayudan a contextualizar el aprendizaje [Dys09] [Klo11]. Por ello, la combinación de los distintos espacios en un ULE tiene potenciales beneficios, como por ejemplo, disminuir las barreras entre el aprendizaje en ámbitos formal e informal, y ha sido marcado los últimos años por la comunidad investigadora en Aprendizaje Apoyado por Tecnología (TEL, de las siglas en inglés) como uno de los retos claves a explorar [Mil13] [Sut12] [Woo10].

Sin embargo, a pesar de los beneficios educativos que pueden aportar dichas situaciones de aprendizaje AS, los docentes siguen teniendo dificultades para realizarlas [DK12] [Mil13] [Spi10] [Woo10]. La comunidad TEL ha englobado los distintos problemas que tienen los profesores para poner en marcha situaciones de aprendizaje en entornos educativos complejos (en general, sin restringirse a ULEs) usando la metáfora “orquestración del aprendizaje” [Dil09]. Dicha metáfora ha despertado gran interés en la comunidad investigadora los últimos años (ver por ejemplo [Bal09] [Ros13]). Bajo el paraguas de la orquestración, distintos autores consideran aspectos como el diseño de las situaciones de aprendizaje, su gestión, la adaptación ante eventos imprevistos, los roles que tienen profesores y estudiantes en dicha orquestración, la percepción de las acciones de los estudiantes, los condicionantes pragmáticos de docentes e instituciones, o el alineamiento de los distintos recursos para conseguir los objetivos de aprendizaje marcados [Pri11].

En los últimos años, muchos autores han propuesto sistemas que permiten ayudar a los profesores en algunos aspectos de la orquestración cuando ponen en marcha situaciones de aprendizaje AS. Algunas de estas propuestas proporcionan a los docentes herramientas de autoría para permitirles crear las situaciones de aprendizaje (ver por ejemplo [Klo11] [Mar11] [Mul12]). Otros autores incluyen funcionalidades de monitorización para ayudar en la evaluación de los estudiantes (ver por ejemplo [Cal09] [Fac04]). Otros tratan de ayudarles en la gestión de las situaciones de aprendizaje, por ejemplo, automatizando la creación de instancias de herramientas [Liv08] [Pou13]. Sin embargo, la mayoría de las propuestas son sistemas independientes, que están aislados de las herramientas existentes ya usadas por docentes e instituciones. A esto se añade que la mayoría de los sistemas propuestos están diseñados para apoyar un tipo específico de situación de aprendizaje o actividad (como por ejemplo un tipo específico de juego o una secuencia de artefactos de aprendizaje geolocalizados) no integrada con el resto de actividades habituales del docente. Además, los autores que proponen herramientas de autoría, restringen a los docentes a las posibilidades pedagógicas y tecnológicas de las mismas, con lo que su uso se limitaría a los docentes e instituciones afines a ellas. Todas estas limitaciones obstaculizan la integración de las propuestas en el día a día de los docentes, que es un factor importante en la orquestración del aprendizaje [Cue13] [Pri14b].

En este contexto, el problema general que se aborda en esta tesis es *cómo la tecnología puede ayudar a los profesores a orquestrar situaciones de aprendizaje AS que no estén aisladas de la práctica actual de los profesores, y que puedan ser apoyadas por herramientas educativas TIC que ya usen dichos profesores.*

La estructura del resto del documento es la siguiente. En la Sección 2 se describe la metodología seguida en la tesis doctoral. La Sección 3 explica los objetivos marcados y la Sección 4 los principales resultados obtenidos. Por último, la Sección 5 resume las conclusiones obtenidas del trabajo de investigación, así como posibles vías de trabajo futuro.

2. Metodología

De entre los distintos paradigmas de investigación existentes, esta tesis se enmarca en el paradigma *interpretativo* [Coh07] [Cre09] [Gub94] [Orl91], debido a que sus suposiciones encajan bien con el fenómeno investigado (situaciones de aprendizaje AS) y su contexto (personas y organizaciones de personas). Con este marco de referencia, en la tesis se ha seguido la *Metodología de Investigación de Desarrollo de Sistemas* [Nun90]. Dicha metodología define un ciclo de vida del proceso de investigación compuesto por cinco fases:

1. **Crear un marco conceptual.** Fase que incluye la identificación del problema de investigación y la formulación de las preguntas de investigación. El problema de investigación debe ser original y significativo en el campo. Además, debe justificarse la relevancia de las preguntas de investigación. Dichas preguntas de investigación deben discutirse en el contexto de un marco conceptual adecuado. El marco conceptual conduce a la construcción de teoría, que puede ser de distintos tipos, como por ejemplo, declaración de “verdad”, formulación de conceptos, creación de métodos o desarrollo de teorías. Esta fase también incluye la propuesta de una solución del problema de investigación. Dicha propuesta puede requerir el desarrollo de un sistema para demostrar la validez de la solución.
2. **Desarrollar una arquitectura de sistema.** Fase que incluye la definición de objetivos del trabajo de desarrollo y la definición de requerimientos y funcionalidades del sistema resultante que permitirá alcanzar dichos objetivos. Estos requerimientos deberían ser definidos de manera que puedan ser validados en la fase de evaluación. Esta fase implica también la definición de la arquitectura del sistema resultante, la cual proporciona una hoja de ruta en el proceso de construcción del sistema. La arquitectura pone en perspectiva los componentes del sistema, especifica las funcionalidades de dicho sistema, y define las relaciones estructurales y las interacciones dinámicas entre sus componentes.
3. **Analizar y diseñar el sistema.** Fase que involucra todo lo relacionado con el diseño del sistema y las decisiones de diseño: la comprensión del dominio de estudio, la aplicación de conocimiento científico y técnico relevante, la propuesta y exploración de varias alternativas, las decisiones finales de diseño, y la especificación del sistema (por ejemplo, estructuras de datos, bases de datos, bases de conocimiento, módulos y funciones del programa, etc.). Estas especificaciones de diseño deberían usarse como guía de referencia en la implementación del sistema.
4. **Construir el sistema.** Fase consistente en la implementación (construcción) del sistema. A menudo, los investigadores realizan su investigación creando un prototipo. Sin embargo, para poder probar el sistema en el mundo real, es necesario trabajar para convertir el prototipo en un sistema funcional, usable en el dominio de interés. Este proceso de implementación del sistema funcional puede proporcionar a los investigadores conocimientos

sobre las ventajas y desventajas de los conceptos, marcos, y alternativas de diseño elegidas. La experiencia y conocimiento acumulados ayudan a rediseñar el sistema, por ejemplo, en posteriores ciclos del proceso de investigación.

5. **Experimentar, observar y evaluar el sistema.** Fase consistente en la evaluación del sistema, basada en el marco conceptual y los requerimientos del sistema definidos en fases anteriores. Pueden realizarse distintos tipos de evaluación, como experimentos, u observaciones del impacto del sistema en individuos, grupos u organizaciones (por medio de encuestas, estudios de caso, investigación acción, etc.). El desarrollo es un proceso evolucionario. El conocimiento adquirido gracias al desarrollo del sistema lleva generalmente a nuevos desarrollos del sistema, o incluso al descubrimiento de una nueva teoría para explicar nuevos fenómenos observados.

En la última fase del ciclo de vida de la Metodología de Investigación de Desarrollo de Sistemas se ha seguido el Modelo de Evaluación Receptivo Orientado al Evaluando (EREM, de las siglas en inglés) [JA09]. El EREM es un marco concebido como modelo de evaluación para un amplio rango de entornos de aprendizaje colaborativos y ubicuos. Proporciona una guía clara y comprensible a investigadores envueltos en la evaluación de innovaciones en este tipo de entornos. El marco es especialmente útil para investigadores noveles, debido a que propone una organización específica de la complejidad del campo. El EREM es un modelo que enfatiza la idea de realizar evaluaciones centradas en el fenómeno evaluado (*evaluando*), y se enmarca en la evaluación denominada “receptiva” [Sta04], fomentando la respuesta (receptividad) a los problemas reconocidos por los participantes en las evaluaciones. El método de evaluación EREM tiene una perspectiva de investigación subyacente interpretativa [Coh07] [Gub94] [Mil94] [Orl91], que no persigue resultados estadísticamente relevantes ni generalizaciones, sino una comprensión profunda del fenómeno particular que se estudia [Gub81].

Para realizar cada evaluación, se formó un equipo de evaluación compuesto por distintos investigadores del grupo de investigación GSIC/EMIC. Durante el diseño de evaluación, se realizó un proceso de reducción anticipada de datos [Mil94] para explorar la pregunta de investigación, creando un esquema de “pregunta de investigación – problema – tópicos – preguntas de información”. Así, se definieron problemas, como organizadores conceptuales principales del proceso de evaluación. Dichos problemas se dividieron en tópicos para ayudar a entender las diferentes dimensiones de los problemas. Del mismo modo, cada tópico fue explorado mediante varias preguntas de información. Este esquema “pregunta de investigación – problema – tópicos – preguntas de información” guió también la recogida de datos durante el proceso de evaluación, la cual fue realizada usando un amplio rango de fuentes de datos e informantes. Se usaron múltiples técnicas de recogida de datos, entre las que se incluyen: colección de distintos tipos de artefactos generados por los participantes, mediciones de tiempo, grabaciones de operaciones realizadas en computadoras, observaciones, cuestionarios y entrevistas. Como es habitual en la filosofía interpretativa, las técnicas de recogida de datos tuvieron una perspectiva cualitativa pronunciada [Coh07]. También se usaron múltiples métodos de evaluación (análisis de características de sistemas, estudios pilotos y estudios de evaluación). Debido a que se usaron técnicas de recogida cualitativas y cuantitativas (estas últimas en menor medida) y múltiples métodos de evaluación, puede afirmarse que se usaron métodos mixtos [Cre09], y dicha terminología se usa en parte de los trabajos de evaluación. A medida que se fue avanzando en la tesis y ganando conocimiento del

problema de investigación, se incrementó la perspectiva cualitativa, y se enfatizó la naturaleza cualitativa de la investigación realizada.

En el análisis de datos se utilizó el esquema de reducción anticipada como árbol inicial de categorías para el proceso de codificación, y por lo tanto, usando una estrategia dominante deductiva en la creación de un conjunto inicial de códigos [Cre09] [Mil94] [Pop00]. Los principales instrumentos que se usaron para el análisis de datos fueron documentos de texto, hojas de cálculo y el software NVivo³. Finalmente, el equipo de evaluación interpretó los datos y definió los hallazgos.

Con respecto a las estrategias seguidas para asegurar la calidad, el paradigma interpretativo, de manera distinta que otros paradigmas de investigación que basan sus criterios de calidad en fiabilidad, viabilidad interna/externa y objetividad, basa sus criterios de calidad en las nociones de confiabilidad, credibilidad, posibilidad de transferencia y posibilidad de confirmación [Coh07] [Gub81] [Kra09] [Mil94] [She04]. En la tesis se usaron distintas estrategias para asegurar la calidad y rigor del proceso de investigación. Algunas de ellas son: involucración durante meses de trabajo con los distintos profesores y observación constante en el campo; verificación de hallazgos e interpretaciones con informantes; integración de los informes de observación en un histórico único, que permitía una descripción detallada del fenómeno de estudio, la cual se transmitía al equipo de evaluación; revisión entre pares en el equipo de investigación para evitar sesgos; exploración de los sistemas en distintos contextos educativos; triangulación de fuentes de datos, métodos e investigadores.

En la tesis se realizaron tres ciclos del proceso marcado en la Metodología de Investigación de Desarrollo de Sistemas. En cada ciclo, se plantearon preguntas de investigación, que guiaban en la formulación de propuestas y en la creación de sistemas. Durante la fase de evaluación, se formulaban nuevas preguntas de investigación que ayudaban a evaluar el sistema (generalmente, dividiendo las iniciales en sub-preguntas más específicas). Los siguientes párrafos resumen el proceso seguido en los tres ciclos realizados.

- **Ciclo 1.** En la primera fase del primer ciclo, observaciones de campo realizadas en trabajos de investigación relacionados con orquestación del aprendizaje previos a la tesis [MC12b] [Pri13a] [Pri14a], junto con una revisión de la literatura de la orquestación del aprendizaje y de aprendizaje móvil, ubicuo y a través de espacios, condujeron a la definición del problema que guía la investigación a lo largo de la tesis: la orquestación por parte del docente de la orquestación de situaciones de aprendizaje AS. En el primer ciclo del proceso, la investigación se centró en una pregunta de investigación relacionada con la creación, despliegue y puesta en marcha de situaciones de aprendizaje que involucran espacios web y físicos. Se pretendía solucionar las limitaciones de propuestas existentes en el campo para el despliegue e integración de las distintas actividades educativas realizadas y herramientas usadas, sin alejarse de la práctica docente existente. Este ciclo resultó en dos contribuciones: un constructo, consistente en un modelo de artefactos *posicionables* en un espacio físico (*modelo de POI*, siglas en inglés de Punto de Interés); y un sistema (*GLUEPS-AR*), el cual, usando dicho modelo, tenía como objetivo ayudar a los profesores a crear, desplegar y poner en marcha situaciones de aprendizaje AS. Teniendo como guía las limitaciones de las propuestas existentes, se definieron los requerimientos de diseño de *GLUEPS-AR*, su

³<http://www.qsrinternational.com/products.aspx>. Último acceso Abril 2015.

arquitectura (fase 2), las especificaciones de diseño (fase 3), y se creó un prototipo inicial, y un posterior sistema funcional (fase 4). Para los procesos de desarrollo software de la tesis, se siguió un modelo de desarrollo iterativo e incremental, debido a que encaja bien con la metodología de investigación subyacente. Finalmente, el sistema fue evaluado (fase 5), siguiendo el modelo EREM de evaluación. La evaluación consistió en un análisis sistemático de características, un estudio piloto, y un estudio de evaluación.

- **Ciclo 2.** Los resultados del primer ciclo ayudaron a identificar pequeñas mejoras necesarias en el sistema para proporcionar apoyo a los múltiples aspectos de la orquestación de situaciones de aprendizaje AS. También se identificó una limitación importante que afectaba a la orquestación, relacionada con la flexibilidad, guiada por las decisiones pedagógicas del docente, en la gestión de los artefactos de aprendizaje durante la puesta en marcha de las actividades AS (por ejemplo, para permitir a los estudiantes elegir las herramientas a usar o la ubicación donde crear/acceder a los artefactos de aprendizaje). Por ello, en la primera fase del segundo ciclo, se realizó un nuevo estudio del estado de la técnica, centrado en la mencionada flexibilidad, y se plantearon nuevas preguntas de investigación sobre cómo la tecnología podía ayudar en dicha flexibilidad. También se continuó con la pregunta de investigación global de la tesis, el soporte a la orquestación de las propuestas a los múltiples aspectos de la orquestación, que también fue explorada en este ciclo. Como solución al problema de la gestión flexible de artefactos de aprendizaje en la puesta en marcha de situaciones de aprendizaje AS, se propone la noción de cubo de aprendizaje (en inglés, *learning bucket*): un contenedor de artefactos de aprendizaje *posicionables* en distintos espacios. Así mismo, se propone el *Bucket-Server* (servidor de cubos), un sistema que implementa la noción de *learning bucket* para ayudar a los profesores en la mencionada flexibilidad. En este segundo ciclo, se creó el sistema *Bucket-Server* (fases 2-4), y se evaluó su uso independiente de *GLUEPS-AR* (fase 5). También se integró el *Bucket-Server* con *GLUEPS-AR* (fases 2-4) y se evaluó el apoyo a la orquestación ofrecido por el sistema resultante (fase 5). Al igual que en el ciclo 1, las preguntas de investigación planteadas al inicio del ciclo fueron concretadas en la evaluación en nuevas preguntas de investigación centradas en las propuestas, y se siguió el modelo EREM para realizar los trabajos de evaluación.
- **Ciclo 3.** Además de refinar los sistemas con mejoras menores (por ejemplo, relacionadas con el interfaz de usuario), en la primera fase del tercer ciclo se exploró si las propuestas podrían ser fácilmente ampliadas para apoyar a los profesores en la orquestación de situaciones de aprendizaje que incluían otros tipos de espacios además de web y físicos. Así, este ciclo se centró en otro espacio virtual, explorado de manera intensiva en el dominio educativo durante años: los 3DVWs. Tras un análisis de la literatura del uso de 3DVWs en la educación, y más concretamente, en situaciones de aprendizaje AS, se planteó la pregunta de investigación de cómo la tecnología podía ayudar a orquestar situaciones de aprendizaje de dicho tipo que podían incluir espacios físicos, web y 3DVWs, integraban las distintas actividades realizadas y herramientas usadas, y tenían en cuenta la práctica docente existente. Durante los ciclos anteriores se había detectado una limitación de *GLUEPS-AR* en las posibilidades de ofrecer una percepción de las acciones de los estudiantes, y se habían realizado pruebas de concepto incluyendo avatares en clientes móviles AR en el primer ciclo y Globos Terráqueos Virtuales 3D [Rak08] (por ejemplo, Google Earth⁴) en el segun-

⁴<https://www.google.com/earth/>. Último acceso Abril 2015.

do. Estas pruebas, junto con la revisión de la literatura, condujeron a proponer ampliar GLUEPS-AR para permitir la integración de los Globos Terráneos Virtuales usados como 3DVWs en las situaciones de aprendizaje soportadas por GLUEPS-AR. Así, se definieron los requerimientos de diseño y la arquitectura (fase 2), las especificaciones de diseño (fase 3), y se construyó el sistema, creando una nueva versión de GLUEPS-AR (fase 4). Posteriormente (fase 5), se realizó una evaluación en la que, al igual que en el resto de ciclos, se siguió el modelo EREM y las preguntas de investigación formuladas al inicio del ciclo se concretaron para centrarse en el sistema desarrollado (la nueva versión de GLUEPS-AR, así como su integración con el Bucket-Server).

3. Objetivos

El objetivo general de la tesis es dar respuesta a la pregunta de investigación: *¿Cómo puede la tecnología ayudar a los profesores a orquestar situaciones de aprendizaje AS que no estén aisladas de la práctica actual de los profesores, y que puedan ser apoyadas por herramientas educativas TIC que ya usen dichos profesores?* Con el fin de conseguir dicho objetivo general, se han definido dos objetivos particulares⁵, los cuales fueron especificados a lo largo del proceso de investigación descrito en la sección anterior.

1. **Apoyar a los docentes en el despliegue asequible de situaciones de aprendizaje AS. Dichas situaciones de aprendizaje deberían poder incluir espacios de aprendizaje web, físicos y 3DVW, permitir la utilización de herramientas TIC que ya usen dichos profesores, y no estar aisladas de la práctica actual de los profesores.**

Diferentes autores proponen soluciones para ayudar a los docentes a desplegar sus diseños de aprendizaje en un espacio (por ejemplo, web, físico o 3DVW), y para ayudar a los docentes a desplegar sus diseños en distintos espacios. Sin embargo, dichas propuestas suelen limitar a los profesores a usar algunas tecnologías específicas, normalmente distintas que las que ellos ya usan (por ejemplo, proponiendo nuevos VLEs, aplicaciones AR o 3DVWs). Esto puede aislar las actividades soportadas por dichas propuestas de otras actividades que realicen los profesores que las usan. Por lo tanto, se hacen necesarias soluciones alternativas que puedan ampliar el rango de actividades y herramientas que aquél que permiten las actuales propuestas, permitiendo así a los docentes desplegar, de una forma asequible, situaciones de aprendizaje AS que puedan embeberse en su práctica educativa actual.

2. **Apoyar a los docentes en la gestión flexible de artefactos de aprendizaje generados por docentes y estudiantes durante la puesta en marcha de situaciones de aprendizaje AS, de manera guiada por las decisiones pedagógicas del docente. Dichas situaciones de aprendizaje deberían poder incluir espacios de aprendizaje web, físicos y 3DVW, permitir la utilización de herramientas TIC que ya usen dichos profesores, y no estar aisladas de la práctica actual de los profesores.**

⁵En la presente tesis, se consideran objetivos particulares a aquellos objetivos de investigación definidos y abordados durante el proceso de investigación en su conjunto, y no a los objetivos iniciales planteados al principio de la investigación

Existen propuestas que permiten realizar situaciones de aprendizaje AS, con una cierta flexibilidad en la gestión de los artefactos de aprendizaje durante la puesta en marcha de las actividades (por ejemplo, permitiendo a los estudiantes elegir las herramientas a usar [Con14] [DJ10] [Mik13]). Dicha flexibilidad puede ayudar a metodologías pedagógicas centradas en el estudiante, y a compartir la carga de orquestación con los estudiantes, lo cual puede ser un factor importante en entornos ubicuos [Sha13]. Sin embargo, dichas propuestas no suelen permitir que los docentes puedan regular el grado de flexibilidad proporcionado a los estudiantes, y normalmente están aisladas de la práctica actual del docente. Por lo tanto, se hacen necesarias nuevas soluciones que permitan que los profesores puedan introducir un equilibrio controlado entre el guiado y la libertad que se les proporciona a los estudiantes en la gestión de artefactos de aprendizaje durante la puesta en marcha de situaciones de aprendizaje AS. Además, dichas nuevas soluciones deberían permitir situaciones de aprendizaje más integradas en la práctica diaria del docente que aquéllas que permiten las propuestas actuales.

4. Resultados

Esta sección resume las principales contribuciones de la tesis, así como las publicaciones más relevantes aceptadas hasta el momento de presentación de la tesis doctoral, y los proyectos de investigación relacionados con los trabajos de investigación realizados en la tesis.

4.1 Contribuciones

Las principales contribuciones de la tesis son dos constructos (*modelo de POI* y noción de *learning bucket*) y dos sistemas que implementan dichos constructos (*GLUEPS-AR* y *Bucket-Server*).

- **Modelo de POI.** Como se explicó en la Sección 1, hay una limitación en las propuestas actuales para poder permitir situaciones de aprendizaje AS que hagan uso de diferentes tecnologías que los docentes puedan utilizar en su práctica. Estas tecnologías incluyen, por ejemplo, múltiples VLEs web, clientes AR móviles o 3DVWs. Un problema importante para conseguir la integración de dichas tecnologías en las situaciones de aprendizaje, es que cada una de ellas utiliza un modelo de datos distinto para representar un objeto posicionado en un espacio. Como solución a este problema, y como parte del objetivo 1 de la tesis, se propone el modelo de Punto de Interés (*modelo de POI*, de las siglas en inglés). El modelo de POI representa a un artefacto educativo que puede ser posicionado en un espacio, usando para ello un modelo compatible con las múltiples especificaciones, modelos de datos y sistemas existentes, orientados a posicionar objetos en espacios. Para proponer el modelo, se combinaron análisis ascendente (*bottom-up*) y descendente (*top-down*), revisando tanto aplicaciones software existentes que permiten posicionar objetos en un espacio, como especificaciones y modelos de datos de la literatura orientados a representar objetos en un espacio. El análisis se realizó en dos fases (en diferentes ciclos del proceso de investigación), una primera fase centrada en espacios físicos y aplicaciones AR, y una segunda fase, confirmando la validez del modelo para ampliarlo a un diferente espacio, analizando Globos Terráqueos Virtuales. Para proponer el modelo, se seleccionaron un reducido número de

atributos, de entre los múltiples que implementan las distintas especificaciones y aplicaciones, en base al propósito de representar artefactos de aprendizaje. El modelo de POI resultante permite que un artefacto educativo posicionado en un espacio, pueda representarse usando múltiples modelos de datos, especificaciones y aplicaciones software. Por lo tanto, es un factor clave para conseguir el “flujo” de artefactos de entre una aplicación a otra, y en consecuencia, de un espacio a otro (a través de espacios). El modelo de POI se ha implementado en los sistemas GLUEPS-AR y Bucket-Server.

- **Noción de *learning bucket*.** Como parte del objetivo 2 de la tesis, los *learning buckets* tienen como finalidad que los docentes puedan introducir una cierta y controlada flexibilidad en la gestión de los artefactos de aprendizaje durante la puesta en marcha de situaciones de aprendizaje AS. Un *learning bucket* es un contenedor configurable de artefactos educativos que pueden ser creados/accedidos en distintos espacios. Un *learning bucket* puede embeberse en entornos de aprendizaje en distintos espacios (por ejemplo, en un VLE web, un cliente AR móvil usado en un espacio físico, etc.). Los *learning buckets* son creados por docentes en el momento del diseño educativo, son incluidos en actividades de una situación de aprendizaje, y son configurados con *restricciones* (limitaciones para especificar lo que los estudiantes podrán hacer en el *learning bucket* durante la puesta en marcha de las actividades, como pueden ser las herramientas a usar, los tipos de posicionamiento permitidos, etc.). Un *learning bucket* puede estar vacío cuando se crea, y es llenado con artefactos de aprendizaje por los estudiantes durante la puesta en marcha, desde el entorno de aprendizaje donde esta embebido. Dichos artefactos pueden ser generados usando múltiples herramientas existentes y de amplio uso, y pueden ser posicionados en diferentes espacios usando distintos tipos de posicionamiento (mediante coordenadas geográficas, marcadores AR, códigos QR, etc.). Los *learning buckets* han sido implementados en el sistema Bucket-Server.
- **GLUEPS-AR.** Alineado con el objetivo 1 de la tesis, *GLUEPS-AR* es un sistema que implementa el modelo de POI, y cuyo propósito es apoyar a los docentes en múltiples aspectos de la orquestación de situaciones de aprendizaje AS. Uno de los cometidos de GLUEPS-AR es permitir a los docentes desplegar sus diseños educativos en los entornos tecnológicos en los que se pondrán en marcha las actividades. El diseño educativo o de aprendizaje (*learning design* en inglés) [Kop05] es un campo de investigación que explora cómo permitir a los docentes hacer explícitas sus ideas pedagógicas por medio de lenguajes estándar interpretables por computadoras, con el fin de facilitar a los docentes compartir y reusar sus diseños. GLUEPS-AR amplía la arquitectura de su sistema predecesor, GLUEPS [Pri13a], que permitía desplegar diseños educativos, que podían haber sido creados por medio de diferentes herramientas de autoría, en múltiples entornos de aprendizaje distribuidos web. Así, GLUEPS-AR, extendiendo el ámbito a entornos que también puedan incluir otros espacios físicos y virtuales, permiten a los docentes desplegar dichos diseños en ULEs. Y lo que es más, GLUEPS-AR configura dichos ULEs, ya que integra entornos de aprendizaje de distintos espacios (por ejemplo, que usen VLEs web, herramientas Web 2.0, clientes AR móviles y Globos Terráqueos Virtuales usados como 3DVWs). Además, GLUEPS-AR permite a los docentes elegir entre múltiples sistemas existentes para la creación de dichos ULEs, posibilitando el flujo de artefactos entre espacios.
- **Bucket-Server.** Alineado con el objetivo 2 de la tesis, el *Bucket-Server* es un sistema

que implementa ambos, el modelo de POI y la noción de *learning bucket*. El Bucket-Server tienen como finalidad ayudar a los docentes en la gestión flexible de los artefactos de aprendizaje durante la puesta en marcha de situaciones de aprendizaje AS, ayudando así también a compartir la carga de orquestación entre docentes y estudiantes. El Bucket-Server permite crear *learning buckets*, configurarlos con restricciones (limitando así lo que posteriormente se puede hacer en ellos), y gestionar sus artefactos educativos, los cuales pueden ser posicionados en distintos espacios con diferentes tipos de posicionamiento. De esta forma, los estudiantes, bajo las restricciones definidas por el profesor, pueden tomar decisiones sobre (entre otras) las herramientas a usar y la posición de los artefactos a crear/acceder. El Bucket-Server ofrece una Interfaz Programática de Aplicación (API, de las siglas en inglés) que pueden usar distintas aplicaciones software en distintos espacios. La propuesta tecnológica Bucket-Server se exploró principalmente en el segundo ciclo del proceso de investigación. Se ha creado un prototipo de Bucket-Server y evaluado su uso: (1) con una integración directa con VLEs web y clientes AR móviles, por lo tanto, permitiendo a los docentes crear y gestionar *learning buckets* directamente desde el VLE, y acceder a los *learning buckets* y sus artefactos desde el VLE y desde clientes AR móviles; y (2) con su integración con GLUEPS-AR, y en consecuencia, permitiendo a los docentes crear sus diseños educativos en distintas herramientas de autoría, incluir y configurar *learning buckets* en actividades de dichos diseños, y desplegar los diseños en ULEs formados por VLEs web y clientes AR móviles.

4.2 Publicaciones

Los siguientes documentos, que describen los trabajos y resultados de la tesis, han sido publicados o aceptados para su publicación en el momento de depositar la tesis (todos ellos en publicaciones con revisión entre pares). La lista únicamente incluye aquellas publicaciones en las que el autor de la presente tesis doctoral es primer autor.

- Publicaciones en revistas internacionales indexadas en JCR:

- (R1) Muñoz Cristóbal, J.A., Prieto Santos, L.P., Asensio Pérez, J.I., Martínez Monés, A., Jorrín Abellán, I.M., Dimitriadis, Y. Deploying learning designs across physical and web spaces: Making pervasive learning affordable for teachers *Pervasive and Mobile Computing*. 14:31-46, 2014.
- (R2) Muñoz Cristóbal, J.A., Martínez Monés, A., Asensio Pérez, J.I., Villagrà Sobrino, S.L., Hoyos Torío, J.E., Dimitriadis, Y. City Ads: Embedding Virtual Worlds and Augmented Reality in Everyday Educational Practice *Journal of Universal Computer Science*. 20(12):1670-1689, 2014.
- (R3) Muñoz Cristóbal, J.A., Jorrín Abellán, I.M., Asensio Pérez, J.I., Martínez Monés, A., Prieto Santos, L.P., Dimitriadis, Y. Supporting Teacher Orchestration in Ubiquitous Learning Environments: A Study in Primary Education *IEEE Transactions on Learning Technologies*. 8(1):83-97, 2015.
- (R4) Muñoz Cristóbal, J.A., Prieto Santos, L.P., Asensio Pérez, J.I., Martínez Monés, A., Jorrín Abellán, I.M., Dimitriadis, Y. Coming down to Earth: Helping teachers use 3D virtual worlds in across-spaces learning situations *Educational Technology & Society*. 18(1):13-26, 2015.

- Publicaciones en revistas internacionales no indexadas en JCR:
 - (R5) Muñoz Cristóbal, J.A., Prieto Santos, L.P., Asensio Pérez, J.I., Jorrín Abellán, I.M., Dimitriadis, Y. Orchestrating TEL situations across spaces using Augmented Reality through GLUE!-PS AR *Bulletin of the Technical Committee on Learning Technology*. 14(4):14-16, Octubre 2012.
- Publicaciones en libros de actas de conferencias internacionales:
 - (C1) Muñoz-Cristóbal, J.A., Asensio-Pérez, J.I., Prieto-Santos, L.P., Jorrín-Abellán, I.M., Dimitriadis, Y., Martínez-Monés, A. Helping educators to deploy CSCL scripts into mainstream VLEs that integrate third-party Web and Augmented Reality Tools *Proceedings of the Workshop on Digital Ecosystems for Collaborative Learning. International Conference of the Learning Sciences, ICLS 2012, Sídney, Australia, Julio 2012*.
 - (C2) Muñoz-Cristóbal, J.A., Prieto-Santos, L.P., Asensio-Pérez, J.I., Jorrín-Abellán, I.M., Dimitriadis, Y. Lost in Translation from Abstract Learning Design to ICT Implementation: a Study Using Moodle for CSCL *Proceedings of the 7th European Conference on Technology Enhanced Learning, EC-TEL 2012, Saarbrücken, Alemania, Septiembre 2012*.
 - (C3) Muñoz-Cristóbal, J.A., Prieto-Santos, L.P., Asensio-Pérez, J.I., Jorrín-Abellán, I.M., Martínez-Monés, A., Dimitriadis, Y. GLUEPS-AR: A System for the Orchestration of Learning Situations Across Spaces Using Augmented Reality *Proceedings of the 8th European Conference on Technology Enhanced Learning, EC-TEL 2013, Paphos, Chipre, Septiembre 2013*.
 - (C4) Muñoz-Cristóbal, J.A., Prieto-Santos, L.P., Asensio-Pérez, J.I., Jorrín-Abellán, I.M., Martínez-Monés, A., Dimitriadis, Y. Sharing the Burden: Introducing Student-Centered Orchestration in Across-Spaces Learning Situations *Proceedings of the 8th European Conference on Technology Enhanced Learning, EC-TEL 2013, Paphos, Chipre, Septiembre 2013*.
 - (C5) Muñoz-Cristóbal, J.A. Helping educators to orchestrate learning situations involving multiple physical and virtual spaces *Proceedings of the Doctoral Consortium at the 8th European Conference on Technology Enhanced Learning, EC-TEL 2013 - DC, Paphos, Chipre, Septiembre 2013*.
 - (C6) Muñoz-Cristóbal, J.A., Asensio-Pérez, J.I., Martínez-Monés, A., Dimitriadis, Y. Orchestrating learning across spaces: Integrating heterogeneous technologies of the existing educational practice *Proceedings of the Orchestrated Collaborative Classroom Workshop. 11th International Conference on Computer Supported Collaborative Learning, CSCL 2015, Gothenburg, Suecia, Junio 2015*.
 - (C7) Muñoz-Cristóbal, J.A., Asensio-Pérez, J.I., Martínez-Monés, A., Prieto-Santos, L.P., Jorrín-Abellán, I.M., Dimitriadis, Y. Bucket-Server: A system for including teacher-controlled flexibility in the management of learning artifacts in across-spaces learning situations *Proceedings of the 10th European Conference on Technology Enhanced Learning, EC-TEL 2015, Toledo, España, Septiembre 2015*. Aceptado para su publicación.
- Publicaciones en libros de actas de conferencias españolas:

- (C8) Muñoz-Cristóbal, J.A., Prieto-Santos, L.P., Asensio-Pérez, J.I., Martínez-Monés, A., Jorrín-Abellán, I.M., Dimitriadis, Y. Realidad aumentada en educación *Actas de las XXI Jornadas Universitarias de Tecnología Educativa*, JUTE 2013, Valladolid, España, Junio 2013.

4.3 Proyectos

Parte de los trabajos realizados en la tesis conforman la mayoría de los trabajos de investigación realizados para el cumplimiento de los objetivos del siguiente proyecto:

- “EEE-WEB: Orquestando espacios educativos web y especulares”. Fecha: 2012-2014. Entidad financiadora: Plan Nacional de I+D+i, Ministerio de Ciencia e Innovación (TIN2011-28308-C03-02). Entidades participantes: Universidad de Valladolid. Investigador principal: Yannis Dimitriadis. Importe total del proyecto: 160.930€

Además, parte de los trabajos realizados en la tesis generaron las propuestas y conforman la mayoría del trabajo de investigación de los siguientes proyectos regionales y locales concedidos (en concurrencia competitiva):

- “AR-ML: Revisión del estado de la técnica de la Realidad Aumentada al uso de dispositivos móviles en educación (m-Learning)”. Fecha: 2012. Entidad financiadora: Cátedra de Movilidad y Educación de Telefónica y la Universidad de Valladolid (CTEFUva-DIV-2011-02-P3). Entidades participantes: Telefónica, Universidad de Valladolid. Investigador principal: Yannis Dimitriadis. Importe total del proyecto: 3000€
- “AR4AII: Soporte al profesorado en el uso educativo de la Realidad Aumentada con dispositivos móviles”. Fecha: 2012. Entidad financiadora: Cátedra de Movilidad y Educación de Telefónica y la Universidad de Valladolid (CTEFUva-DIV-2011-02-P4). Entidades participantes: Telefónica, Universidad de Valladolid. Investigador principal: Juan I. Asensio-Pérez. Importe total del proyecto: 6000€
- “Soporte al profesorado en el despliegue automático, realización flexible y evaluación de situaciones de aprendizaje ubicuo que hacen uso conjunto de Entornos de Aprendizaje Virtual existentes, aplicaciones de Realidad Aumentada, y Mundos Virtuales 3D”. Fecha: 2014-2016. Entidad financiadora: Junta de Castilla y León (VA277U14). Entidades participantes: Universidad de Valladolid. Investigador principal: Yannis Dimitriadis. Importe total del proyecto: 28.999€

5. Conclusiones

Tal y como se indicó en la Sección 3, el objetivo general de la tesis era responder a la pregunta de investigación *¿Cómo puede la tecnología ayudar a los profesores a orquestar situaciones de aprendizaje AS que no estén aisladas de la práctica actual de los profesores, y que puedan ser apoyadas por herramientas educativas TIC que ya usen dichos profesores?* Con el fin de alcanzar dicho objetivo, se definieron dos objetivos parciales, enfatizando algunos de los actuales retos en la ayuda a los docentes en la orquestación de situaciones de aprendizaje AS:

- (1) **Apoyar a los docentes en el despliegue asequible de situaciones de aprendizaje AS. Dichas situaciones de aprendizaje deberían poder incluir espacios de aprendizaje web, físicos y 3DVW, permitir herramientas TIC que ya usen dichos profesores, y no estar aisladas de la práctica actual de los profesores.** Con el fin de lograr este objetivo, se propuso el modelo de POI y el sistema GLUEPS-AR. Mediante dichas propuestas, los profesores pueden desplegar diseños de aprendizaje (que pueden haber sido creados usando diferentes herramientas de autoría) en múltiples ULEs. Estos ULEs pueden estar formados por distintos VLEs, clientes móviles AR y Globos Terráneos Virtuales, permitiendo por lo tanto que los docentes elijan de entre una variedad de tecnologías existentes, para facilitar la adecuación a su práctica actual. Además, múltiples artefactos virtuales (por ejemplo, generados con herramientas de la Web 2.0) pueden accederse desde los múltiples espacios, consiguiendo el “flujo” de artefactos entre los distintos espacios, ayudando de esta forma a conectar las distintas actividades. Las múltiples evaluaciones llevadas a cabo indican que GLUEPS-AR permite un despliegue asequible de situaciones de aprendizaje AS, así como ayuda a los docentes en múltiples aspectos de la orquestación.
- (2) **Apoyar a los docentes en la gestión flexible de artefactos de aprendizaje que docentes y estudiantes generen durante la puesta en marcha de situaciones de aprendizaje AS, de manera guiada por las decisiones pedagógicas del docente. Dichas situaciones de aprendizaje deberían poder incluir espacios de aprendizaje web, físicos y 3DVW, permitir herramientas TIC que ya usen dichos profesores, y no estar aisladas de la práctica actual de los profesores.** Con el fin de cumplir con este objetivo, se propuso la noción de *learning bucket* y el sistema Bucket-Server. Mediante dichas propuestas, los profesores pueden introducir *learning buckets* en sus actividades, y configurarlos con restricciones para controlar el grado de flexibilidad ofrecida a los estudiantes para gestionar sus artefactos de aprendizaje. Durante la puesta en marcha de las actividades, los estudiantes pueden llenar el *learning bucket* con artefactos de aprendizaje de múltiples tipos (por ejemplo, usando herramientas Web 2.0), los cuales pueden ser posicionados en distintos espacios. Estos *learning buckets* permiten a los estudiantes tomar decisiones tecnológicas (por ejemplo, qué herramientas usar), contextuales (por ejemplo, la posición de los artefactos) y arbitrarias (por ejemplo, el número de artefactos), que son controladas por las restricciones del docente. Los *learning buckets* se han evaluado mediante la integración del Bucket-Server con GLUEPS-AR, y alternativamente mediante la integración directa con VLEs y aplicaciones AR móviles. Las evidencias obtenidas en la evaluación muestran que el Bucket-Server (y por lo tanto los *learning buckets*) permitieron introducir flexibilidad (controlada por el docente) en la gestión de artefactos durante la puesta en marcha de situaciones de aprendizaje AS que estaban integradas con la práctica actual del docente, así como también ayudaron en múltiples aspectos de la orquestación.

El cumplimiento de los dos objetivos parciales de la tesis nos permiten afirmar que se ha conseguido su objetivo general de dar respuesta a la pregunta de investigación planteada. Así, esta tesis muestra cómo mediante constructos como el modelo de POI o la noción de *learning bucket*, y sistemas como GLUEPS-AR y el Bucket-Server, los profesores pueden ser ayudados a orquestar situaciones de aprendizaje AS, integradas con la práctica actual de dichos docentes, y apoyadas por herramientas TIC que dichos docentes usaban con anterioridad.