



MÁSTER EN INGENIERÍA AMBIENTAL
UNIVERSIDAD DE VALLADOLID

TRABAJO FIN DE MÁSTER

WASTEWATER PRETREATMENT WITH MEMBRANES

FANNY MARITZA RIVERA MEJÍA
JULIO 2014

D^a María del Mar Peña Miranda, profesora del Departamento de Ingeniería Química de la Universidad de Valladolid, INFORMA:

Que Fanny Maritza Rivera Mejía ha realizado bajo mi dirección el Trabajo Fin de Máster, del Máster en Ingeniería Ambiental, titulado **WASTEWATER PRETREATMENT WITH MEMBRANES**.

Valladolid, a 25 de Julio de 2014

Reunido el Tribunal designado por el Comité Académico del Máster en Ingeniería Ambiental, para la evaluación de Trabajos Fin de Máster, y después de estudiar la memoria y atender a la defensa del trabajo "**WASTEWATER PRETREATMENT WITH MEMBRANES**", presentado por la alumna Fanny Maritza Rivera Mejía, decidió otorgarle la calificación de _____.

Valladolid, 25 de Julio de 2014

El Presidente

El Secretario

Fdo.:

Fdo.:

Vocal

Fdo.:

WASTEWATER PRETREATMENT WITH MEMBRANES

Fanny Maritza Rivera Mejía – Department of Chemical Engineering and Environmental Technology, Valladolid University, Paseo del Prado de la Magdalena, s/n, 49011, Valladolid, Spain.

Abstract

Direct membrane filtration of municipal wastewater from the city of Valladolid, Spain using an ultrafiltration membrane was investigated to concentrate the particulate organic matter. This is a physical process at 13-15 °C that can be used as pretreatment for wastewater. This pretreatment together with an anaerobic process at low temperature could replace the active sludge process. In the new scheme proposed the permeate from the membrane would go to a posterior anaerobic treatment (UASB reactor operating under psychrophilic conditions) and the accumulated solids would be treated by an anaerobic digestion at 35°C (mesophilic). The aim of this study was to evaluate the membrane filtration conditions. On the lower region of the membrane module results of τ COD 81.842gO₂/L, 45.18gTS/L and 38.03gVS/L were reached. The permeate flux was 13.44 L/m²h with a filtration cycle of 7.75min (backwash time (15s), relaxation (5s), filtration (7.5min.) and a pausing time (5s), and a velocity of the gas 54.57m/h. The range for filtration TMP was 471 to 709.33 mbar. The average removal rate for TSS and VSS was 96.26% and 96.20% respectively and the specific methane production of the accumulated VS was 246.37 mLCh₄/gSV_{fed} and the τ COD average removal rate was 46.10%.

Keywords:

Direct Membrane Filtration, Recovery of Organic Matter, Municipal Wastewater, Accumulated Solids, and Anaerobic digestion 35 °C.

1. Introduction

As time goes along there is an increase of the preoccupation from the population for the environment. The developed countries are applying techniques and procedures to reduce the impacts on Earth. However it's still not enough, changes should be made worldwide and all human beings should be aware of the consequences of their acts. Damages should be repaired and avoided, to live in a sustainable world where there is a balance between environment, society and economy.

Typically, a wastewater treatment plant starts the process by the physical separation of solids that have bigger sizes (garbage) from the stream of domestic or industrial waters using a system of grating, although they can be crushed by special equipments, following a grit removal structure is applied followed by a primary clarifier (which separates the existing suspended solids in the wastewater). To eliminate dissolved metals, precipitation reactions are used. After the primary treatment, a biological treatment is applied, which is based on transforming the dissolved organic matter present in the wastewater to suspended solids which are easily eliminated. For biological treatment the most commonly used is the active sludge process, which consists on using dissolved oxygen to incite the growth of biological organisms that remove substantially the organic matter. This process can also trap particle materials and by ideal conditions, convert ammonia to nitrate, or even to nitrogen gas. Then a secondary clarifier (where the accumulated solids retained from the clarifiers are taken to an anaerobic digestion at 35 °C.). A tertiary treatment is applied to trigger a complete disinfection of the wastewater and so it can be in conditions according to the laws that imply the concentration limits for discharge.

Although these technologies work well in many situations, they have several drawbacks, including the difficulty of growing the right types of microorganisms and the physical requirement of a large site. (EPA 2007). A clear disadvantage for using an aerobic treatment, in this case active sludge is that there is a huge electrical consumption by the application of oxygen for the removal of organic matter. This only increases the amount of solids which later on should be treated. To improve this treatment for urban wastewater, a new scheme is proposed which consists on an intense primary treatment through filtration with membranes. With this pretreatment two streams are obtained, one with concentrated particulate material and the other that only contains psychrophilic dissolved organic matter, with the purpose to benefit from the content of organic matter from the water in the form of methane. These collected wastewater enters to a clarifier (which sediments the solids), then this stream is transferred to the membrane module (which would replace the biological process on a conventional treatment plant).

This pretreatment of the water is considered a physical process which separates the wastewater into two streams. One stream is the filtered water from the module that to accomplish the discharge limit values and to generate biogas can be treated on a UASB reactor at low temperature 15 °C approximately. The second stream is composed of the accumulated solids from the clarifier and lower region of the membrane module; these can be treated by an anaerobic digestion at 35 °C to produce biogas (methane). Wastewater treatment plants can be net energy producers by utilizing organic matter in municipal wastewater that is currently degraded with external energy input (McCarty et al., 2011). Using this type of pretreatments with filtration modules implies a significant energetic saving (avoiding injection of air or pure oxygen), and less area for a station of wastewater treatment (suppression of the secondary clarifier and a biologic reactor, three to five times smaller). Organic matter in raw wastewater is partially converted to biomass which is eventually used for biogas production (energy recovery in some cases). However, the conversion rate to biomass is not high (Rittman and McCarty, 2001). A paradigm shift is necessary: organic matter in wastewater should not be degraded but recovered for energy production. Wastewater from domestic usage contains a significant amount of potential energy (Heidrich et al., 2011).

Human activity consumes a lot of energy, the renewable energies cover a range of energetic sources that are generated naturally and continuously, are respectful for the environment and are inexhaustible practices during time. Biomass production follows the concept of sustainable development. 1Kg of biomass generates 3500Kcal, while 1L of gasoline provides 10000Kcal. (Creus S. A.2004). Anaerobic procedures have a great acceptance for their many advantages it produces fewer solids, it doesn't need tampon requirements, the hydraulic retention time is low and this process has a sub product which is the biogas which is a mixture of gases, Methane (CH₄), Carbon Dioxide (CO₂), Dihydrogen (H₂), Hydrogen Sulfide (H₂S), etc. This biogas contains approximately 50 to 70% of Methane that can be a form of energy during its combustion in motors, turbines or in boilers only or with other fuels. Electrical output of 1.5 kWh can be produced from 1 kg COD via methane production, with the assumption of 40% electric conversion (Van Lier, 2008).

About 75% of organic matter in wastewater could be recovered by DMF (Direct membrane filtration), whereas membrane fouling in DMF could be effectively mitigated by chemically enhanced backwash using NaOCl or citric acid. (Lateed et al. 2013). Direct membrane filtration (DMF) of wastewater has advantages including simplicity of design and maintenance (Ravazzini et al., 2005). Membrane life can be increased in the following ways: 1) Good screening of larger solids before the membranes to protect the membranes from physical damage. 2) Throughput rates that are not excessive, i.e., that do not push the system to the limits of the design. 3) Such rates reduce the amount of material that is forced into the membrane and thereby reduce the amount that has to be re-moved by cleaners or that will cause eventual membrane deterioration. 4) Regular use of mild cleaners. Cleaning so-lutions most often used with MBRs include regular bleach (sodium) and citric acid. The cleaning should be in accord with manufacturer recommended maintenance protocols. (EPA 2007).

The objective of this experiment is to investigate the feasibility of direct membrane ultrafiltration of municipal wastewater with a membrane module operating at low temperatures (13-15 °C). Evaluate the production of biogas from the accumulated particulate matter through an anaerobic digestion at 35 °C (mesophilic). Test different conditions for the proper membrane functioning throughout an intense cleaning and disinfection process.

Membrane separation processes have become a basic unit operation for process design and product development. The main disadvantage of using membranes is the operating costs mostly due to the fouling which leads to consumption of chemical reagents Green cleaning reagents should be developed to replace the traditional oxidants, preventing the production of toxic by-products. (Zhiwei W., et al. 2014). These processes are used in a variety of separation and concentration steps, but in all cases, the membranes must be cleaned regularly to remove both organic and inorganic material deposited on the surface and/or into the membrane bulk. Cleaning/ disinfection is a vital step in maintaining the permeability and selectivity of the membrane in order to get the plant to its original capacity, to minimize risks of bacteriological contamination, and to make acceptable products. (Regula C. et al. 2014). Therefore a complete cleaning and characterization of the membrane was made, at certain temperatures and using different agents for cleaning and disinfection until the membrane was in proper conditions to operate.

2. Materials and methods

2.1 Membrane filtration system

This research project focuses on a system of wastewater treatment with membrane ultrafiltration. It was essential to control the key variables for this system, flow rates for feeding the module and for filtration from the module, transmembrane pressures, gas flow rate necessary to maintain suitable levels for working with the membrane module, timing of the whole cycle of filtration which is continuous (backwashing, relaxation, filtration and pausing). The parameters evaluated were Total Chemical Oxygen Demand, Soluble Chemical Oxygen Demand, Total and Volatile Solids, Total and Volatile Suspended Solids, to guarantee the efficiency of the process and to be conscious of the amount of organic matter inside the module. Other important analyses were Particle Size, Volatile fatty acids and anaerobic biodegradability tests at mesophilic conditions of the accumulated particulate matter.

A schematic representation of the pilot plant used in this study is shown in Figure 1. The urban wastewater is driven by a submerged centrifugal pump (P-01) (The wastewater provided comes from the sewage system in the city of Valladolid, Spain) (stream 1) passing through a rotary screen (RS-01) which feeds a storage tank (T-01) of 700L of capacity where the wastewater is stored. This storage tank is the feeding source for the pilot plant. The wastewater that comes from the sewer drain (SD-01) (stream 2) feeds the wastewater storage tank (T-01) every 6 hours in which the solid material is deposited. The water contained in this tank (stream 3) is pumped continuously to the clarifier (CL-01) with the peristaltic pump model Watson Marlow 520S (P-02) that is cleaned every 4 days to remove the solids. The clarifier has a height of 85cm and it is divided into 3 regions. The inferior region has a height of 20cm, a central region of 40cm and 20cm of diameter. The superior region has a height of 25cm and 30cm of diameter it has a 5cm overflow from the surface. The central and superior regions have in the middle a cylinder of 60cm of height and 5cm of diameter that it's where the wastewater is fed. From the clarifier, the water (stream 4) was pumped by P-03 (peristaltic pump model Watson Marlow 520S) to feed the membrane module (R-01) of 135,9L of capacity; it has a height of 1,8m and 0,31m of diameter. From the membrane module the permeated is stored in a tank (T-02) of 60L of capacity, which is used so that the backwashing pump (P-04, programmable, Watson Marlow 520U) uses this permeate for the backwashing of the membrane.

The module is composed of two principal parts: a region of slow agitation (Inferior Region) for the deposition of retained solids for the filtration and a region of major agitation (Central Region) where the membrane is localized and the gas disperser which would be an advantage specially for the cleaning of the fibers in the module. Figure 2 represents schematically the membrane module with the regions where the samples were taken as well as the fiber bundle (manufactured by ZENON Membrane Solutions Company). The membrane is submerged and surrounded by a cylinder of 0.15m of diameter. Table 1 shows the membrane's properties.

Poly(vinylidene fluoride) (PVDF) membranes have been extensively applied to scientific research and industrial process due to its outstanding properties such as high thermal stability, good chemical resistance and membrane forming properties. Ultrafiltration (UF) membranes have a pore size range of 0.01–0.1 μm , and are usually characterized by their molecular weight cut-off (MWCO). UF process is usually used to remove viruses, emulsified oils, metal hydroxides, colloids, proteins, and other large molecular weight materials from water and other solutions. (Kang G., Cao Y. 2014).

Table 1.

Membrane Properties concerning its fibers, system, module and the operational limits.

Membrane Fibers			Module		
Material	PVDF		Effective Superficial Membrane Area	0.93	m ²
Configuration	Hollow Fiber supported, hydrophilicity		Module Length	68.5	cm
General			Module Diameter	11	cm
External Diameter	2	mm	Active Length of fibers	56	cm
Nominal pore size	0.045	µm	Volume Hold-up	130	mL
			Approximate Fiber Number	300	
System			Operational Limits		
Flux Processed by the System	400-2000	L/d	Maximum Transmembrane Pressure	62KPA at 40°C	
Volume Immersion	20	L	Typical Operational Transmembrane Pressure	10-50KPa at 40°C	
Membrane Configuration	Submerged		Maximum Membrane Temperature	40°C	
			Operational range of pH	5 to 9	

The experiment consisted on optimizing the variables for the filtration process. The module was fed continuously by the entrance shown on Figure 2, with flow rates of 9L/h during 25days, then of 11L/h during 12days and back to 9L/h but with another cycle of filtration (increasing the backwash time to 30s). The wastewater permeates the membrane fibers and the filtration is driven axially to the module (R-01) passing through a pressure transmitter (PT-02), which goes through the fifth stream until it gets to the filtration tank (T-02). The force responsible for the filtration is caused by the programmable peristaltic pump (P-04). This pump is controlled with backwash time (15s or 30s), relaxation (5s), filtration (7.5min.) and a pause (5s) on a continuous cycle which leads to adjusting of the filtration flow rate superior to the inflow, because the membrane does not filtrate continuously all the time. The backwash is essential to avoid the rapid fouling of the pores of the fibers from the membrane module. It consists of a cleaning continuous system that along with the agitation caused by the gas dispersion at the bottom of the membrane module ensure the correct functioning of the system.

The existing biogas or air inside the module is continuously pumped by the compressor (ELECTRO A.D., model C5 P1) (C-01) through the sixth stream and bubbled inside the membrane module by an existing tube on the central axis that has scattering holes on the base of the fibers. The gas flux is controlled by a rotameter (Flow indicator FI-01). The gas region is connected to a pressure transmitter (PT-01), pulse transmitter (E-01), and a water seal (E-02) by the line of the seventh stream.

The obtained information from the pressure and temperature transmitters (PT-01, PT02 and TT-01 respectively) was sent to a computer (E-03) which shows the graphics during the functioning of the filtration system.

Periodically samples were gathered from the central and lower region of the membrane module as well as in the clarifier (which feeds the module) shown on Figure 2 and from the tank where the permeated water is accumulated (T-02).

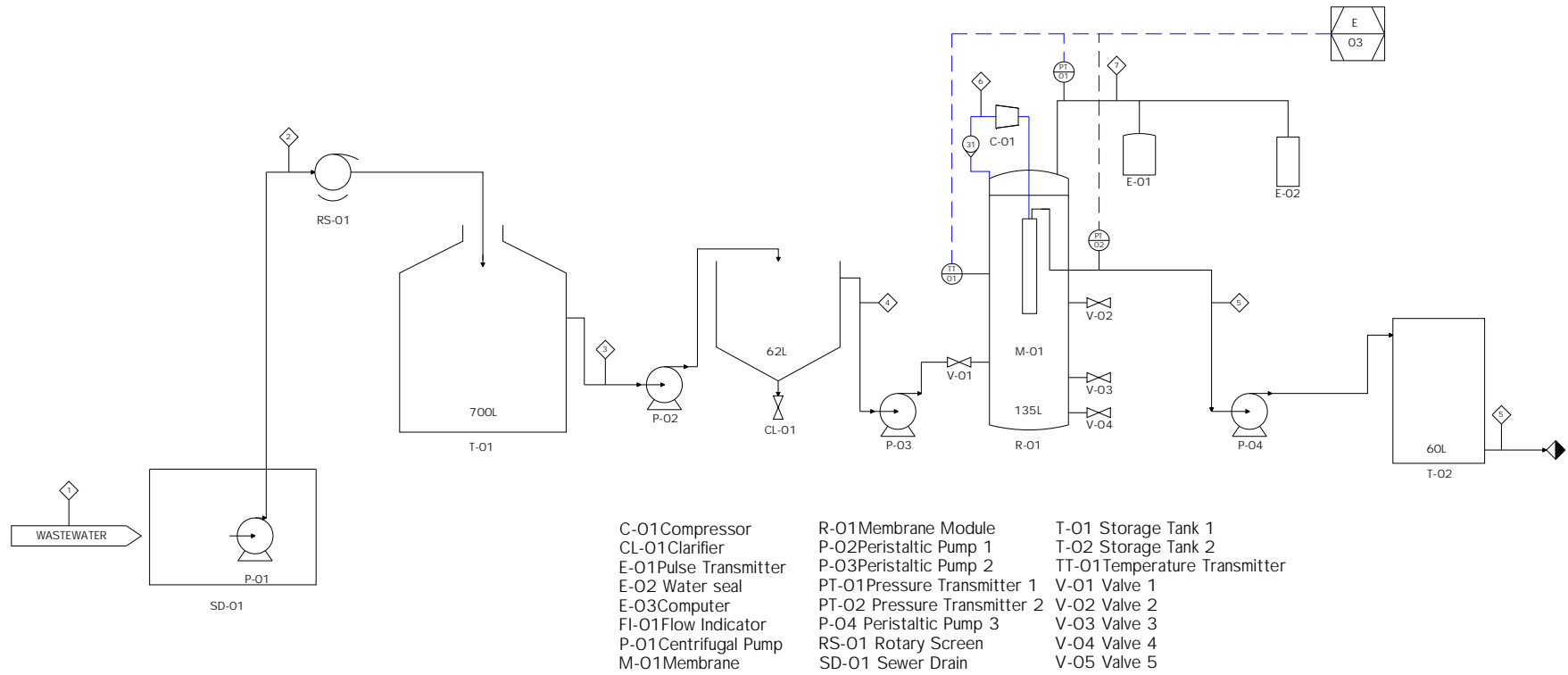

Figure 1. Schematic representation of the pilot plant.

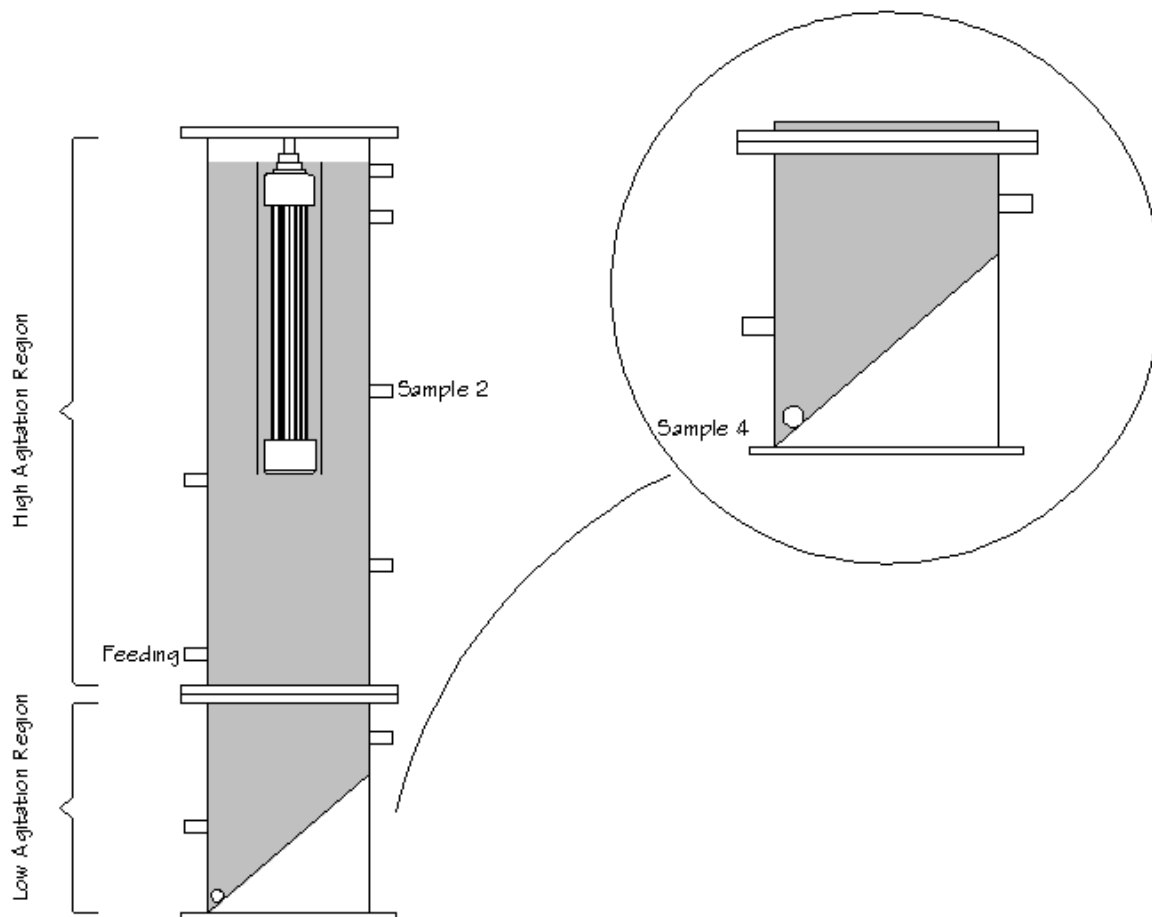

Figure 2. Schematic representation of the membrane module.

2.2 Analysis

Several parameters were analyzed with the purpose to determine the accumulation of the organic matter in the interior of the membrane module (Total and soluble Chemical Oxygen Demand (T_{COD} , s_{COD}), Total and Volatile Solids (TS, VS), Total and Volatile Suspended solids (TSS, VSS), Total Kjeldahl nitrogen and pH). Methods to determine these parameters correspond to the reference book "Standard Methods for the Examination of Water and Wastewater" (APHA, 2005) and others were elaborated by the department of Chemical Engineering and Environmental Technology, Valladolid University.

Ammonium (NH_3): measured by an electrometer, Orion Dual Star that has a Selective Ammonium Electrode Orion 9512HPWBNWP.

Volatile fatty acids: obtained by an equipment of liquid chromatography oh high resolution (HPLC), Shimadzu Class VP V6.10. The sample preparation consists on filtering and then stabilizing with sulfuric acid to set the acid species. The samples are introduced into vials and then are taken to chromatography.

Particle size: It is important to assess the effectiveness of treatment processes. The instrument used for this analysis was the Master Sizer 2000. During the laser diffraction measurement, particles are passed through a focused laser beam. These particles scatter light at an angle that is inversely proportional to their size. The angular intensity of the scattered light is then measured by a series of photosensitive detectors. The number and positioning of these detectors in the Mastersizer 2000 has been optimized to achieve maximum resolution across a broad range of sizes. (Malvern Instruments, 2000).

Transmembrane Pressure (TMP): During the filtration process, and depending on the flow rates, the solid concentration and the filtration cycle, there is a variation of the transmembrane pressures. In order to study the effect of the concentration of solids to the resistance to filtration, the TMP is continuously registered. To observe the evolution of the cycles of washing, relaxation, filtration, and pause needed for the functioning of the module the software PicoLog Data Acquisition from Pico Technology® was used.

Biodegradability of the accumulated solids: This analysis was made by a protocol adopted on previous experiments by the department of Chemical Engineering and Environmental Technology from University of Valladolid. For the evaluation of the biodegradability of the particulated accumulated material in the membrane module and in the clarifier mini-bioidigesters were made in bottles of 160mL of capacity which were composed of known inoculums and the accumulated samples. Total solids (TS) and Volatile Solids are determined from the substrates and inoculum used. Samples from the clarifier and from the lower region on the module were used as substrates. With those values calculations of the amounts of substrate, inoculum, and deionized water are made maintaining the relation 0.4gVS substrate/gVS inoculum. According to the volume of the bottle, half of it is composed of gas and the other half of inoculum, substrate, deionized water, macro and micro nutrients. Sample should be triplicate and a bottle that contains inoculum, macro and micro nutrients, deionized water only for reference. The bottles are filled with Helium and placed in a hot chamber at 37 °C. The equipment used for gas chromatography was the GC Varian 3800. The sample is caught by syringe of 100 µL and then injected to the chromatograph using the method "high sensitivity biogas" to get results of Carbon Dioxide (CO₂), Hydrogen Sulfide (H₂S), Oxygen (O₂), Nitrogen (N₂), and Methane (CH₄). (Elaborated by the department of Chemical Engineering and Environmental Technology, Valladolid University).

Membrane Cleaning and Permeability: This characterization was made before and after the experiment, it consists on cleaning the membrane to improve the pressures in which it operates. A polyvinylchloride cylinder was filled with tap water at 16-19 °C approximately in both circumstances. The membrane was connected to a programmable peristaltic pump (Watson Marlon 520U) and to a pressure transmitter to evaluate the relation between flow rate and pressure filtration. Several flow rates were established, for each, the lowest pressure was registered. TMP is the difference between the initial pressure value and the lowest filtration (or backwashing) pressure. For a complete characterization different phases are made. First, the membrane was characterized without cleaning, then after physical cleaning with tap water and finally with a chemical cleaning. Physical cleaning removes loosely attached materials on membrane surfaces, generally termed 'reversible fouling', while chemical cleaning removes more tenacious materials often termed 'irreversible' fouling. (Judd S. 2011).

Different chemical reagents have been used for cleaning the membrane. After each chemical cleaning the membrane was characterized with tap water at the same temperature on every occasion (16 °C), with the purpose to compare the resistance of the membrane after each cleaning. The characterization before initializing the experiment consisted on first characterizing without any cleaning, then after cleaning the membrane's fibers with tap water, and finally after a chemical cleaning all at 18°C approximately. The chemical cleaning consisted on washing the membrane during four hours with 500 ppm dissolution of Sodium Hypochlorite (NaOCl). After finishing the experiment, a different type of characterization was made; having a difference on the chemical cleaning phase. Different chemical reagents have different effects for removing foulants from fouled membranes: it is generally thought that NaOCl (oxidizing reagent) is effective for removing organic matter from fouled membranes, whereas acids such as citric acid were very effective for removing inorganic matter (Porcelli and Judd, 2010).

The importance of the chemical cleaning is that NaOCl is effective to remove organic colloids and silicates, destructs pathogenic organisms. It's good for oxidizing and disinfecting, can be a membrane swelling agent. The Ethylenediamine tetra-acetic acid (EDTA) and Citric Acid are efficient to prevent of re disposition and/or removal of mineral deposits (Regula C. et al. 2014).

The chemical cleaning consisted on first washing the membrane's pores with 1000ppm dissolution of Sodium Hypochlorite (NaOCl) for three hours (changing the dissolution every hour) at 35 °C. To improve the cleaning, the membrane was put into a concentration of 0.3wt% of Ethylenediamine tetra-acetic acid (EDTA) for 30 min at 38 °C. Since the results were not so efficient the concentration was increased to 0.8wt% for 2 hours at 40 °C (Regula C. et al. 2014). To complete the membrane cleaning another agent was used, 1wt% Citric Acid for 1 hour at 40 °C.

3. Results and discussion

The following figures show the obtained results from the analyzed parameters. Several factors influence the values obtained. The operation conditions were these: From day 1 to 25 with an inflow of 9L/h, filtration flux 10.11L/m²h, filtration cycle of 7.75min (backwash time (15s), relaxation (5s), filtration (7.5min.) and a pausing time (5s), and a velocity of the gas 54.57m/h. From day 27 to 41 the inflow was increased to 11L/h, the filtration flux to 13.44 L/m²h with the same filtration cycle and gas velocity. From day 42 to 50 since the membrane reached excessive values of TMP the inflow was decreased back to 9L/h, filtration flux 10.11L/m²h, the filtration cycle was increased to 8.17min (increasing the backwash time to 30s), relaxation (5s), filtration (7.5min.) and a pausing time (5s), and a velocity of the gas was increased to 70.16m/h the range.

3.1 Central region of the module

3.1.1 τ COD and s COD

COD evaluation indicated an increase of the organic matter during the operation time (50days). Figure 3 indicates the concentrations of τ COD and s COD from the inflow and outflow permeate. The average τ COD value for the inflow was 1.04 gO₂/L, for the s COD 0.66gO₂/L and for the outflow it was 0.55gO₂/L. Concentration of COD in municipal wastewater is in the range of 0.25–0.80 g/L (Metcalf and Eddy, 2003). The values for the outflow are even smaller than the s COD of the inflow this is due to the pore size of the membrane (0.045 μ m), however for the s COD a 0.45 μ m pore size filter is used. This means that in the outflow all COD is present on the τ COD. Figure 4 shows the removal rate of τ COD during the 50days of operation. The average removal rate was 46.10% as shown on figure 4.

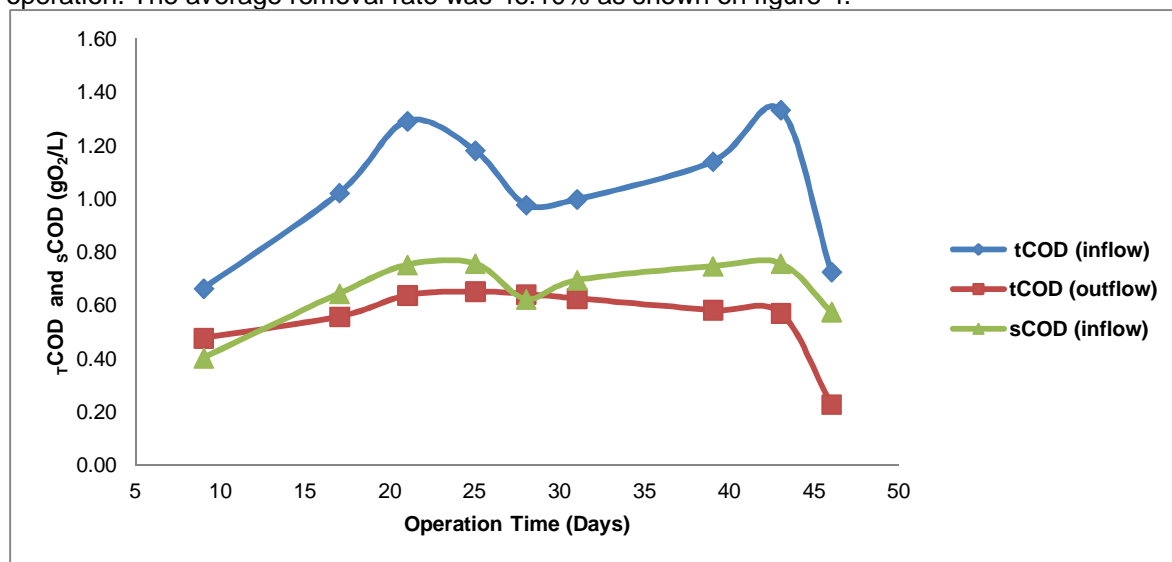

Figure 3. τ COD and s COD from the inflow and outflow during operation time.

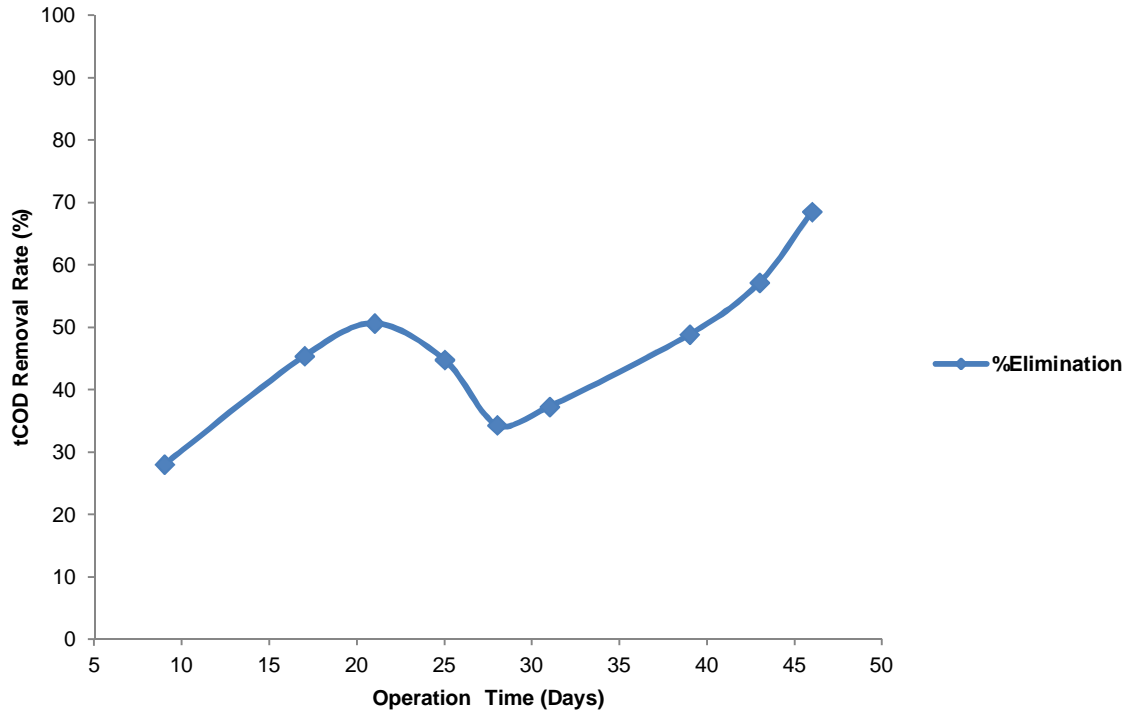

Figure 4. Removal Rate of τ COD during operation time.

3.1.2 TS and VS

Figure 5 indicates the concentrations of TS and VS from the inflow and outflow permeate. The average TS value for the inflow was 0.81gTS/L, and for the VS was 0.43gVS/L. The average TS value for the outflow was 0.58gTS/L, for the VS was 0.25gVS/L. The values are really similar varying only a few. This can be due to the incidences of rains which cause the wastewater to have an oscillation of the characteristic.

Figure 6 shows the removal rate of TS and VS during the 50days of operation. The average removal rate for TS was 27.15% and for VS is 40.61%

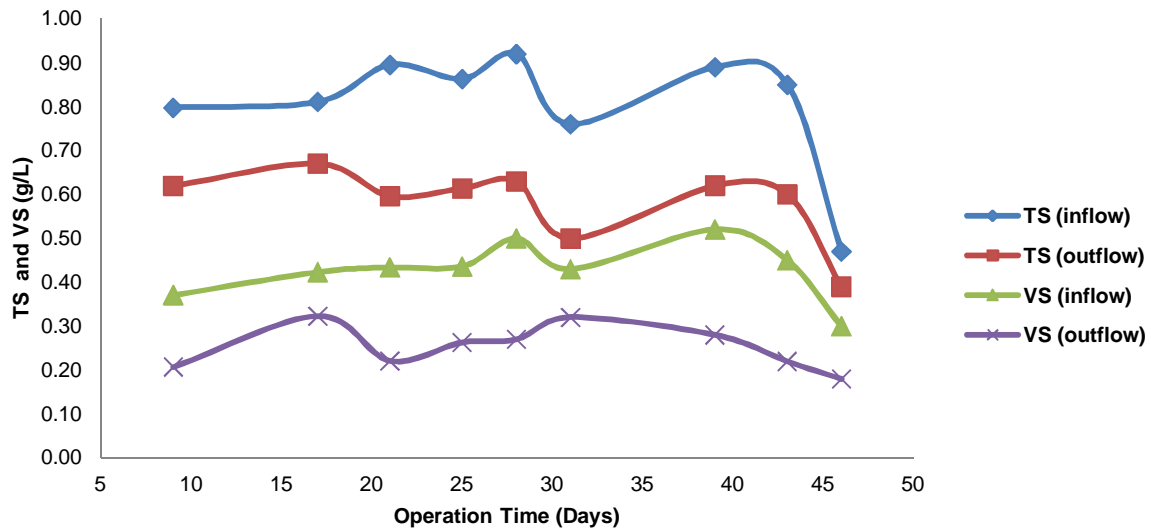

Figure 5. TS and VS from the inflow and outflow during operation time.

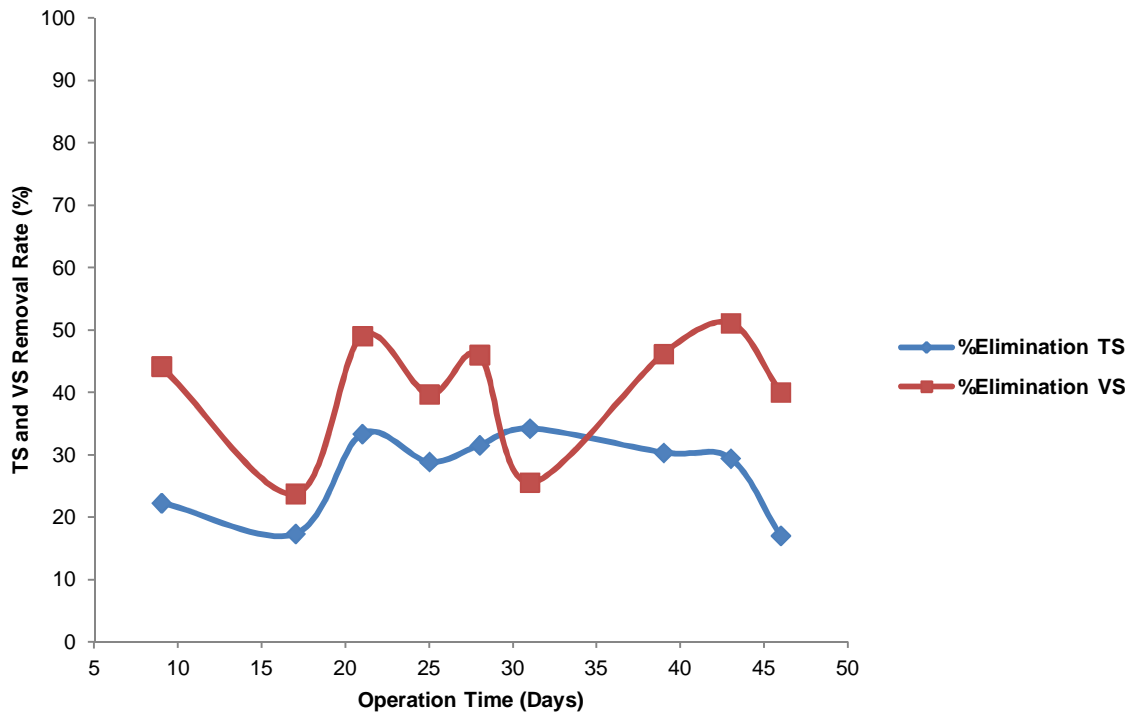

Figure 6. Removal Rate of TS and VS during operation time.

3.1.3 TSS and VSS: Figure 7 indicates the concentrations of TSS and VSS from the inflow and outflow permeate. The average TSS value for the inflow was 0.15gTSS/L, and for the VSS was 0.14gVSS/L. The average TSS value for the outflow was 0.01gTSS/L, for the VSS was 0.01gVSS/L.

Figure 8 shows the removal rate of TSS and VSS during the 50days of operation. The average removal rate for TSS is 96.26% and for VSS is 96.20%. This parameter indicates that the membrane's pores are still in good conditions because values of 0.00gSS/L to 0.01gSS/L are expected. Another result would indicate that the pores are damaged.

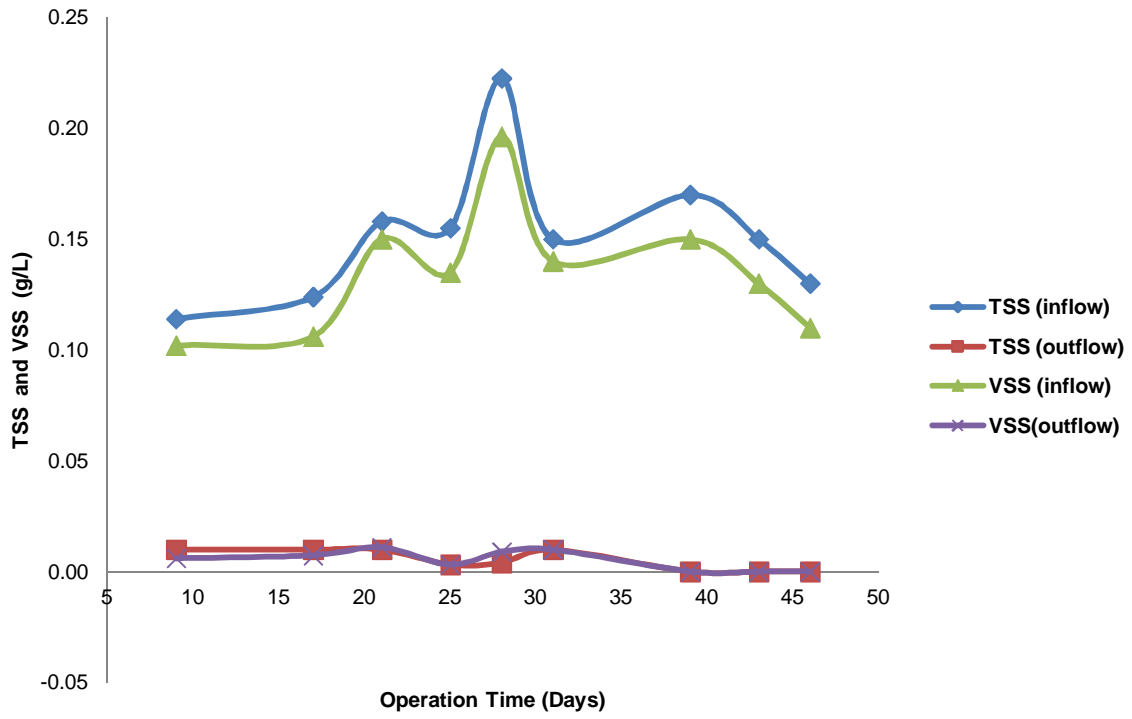

Figure 7. TSS and VSS fed and filtered from the module during operation time.

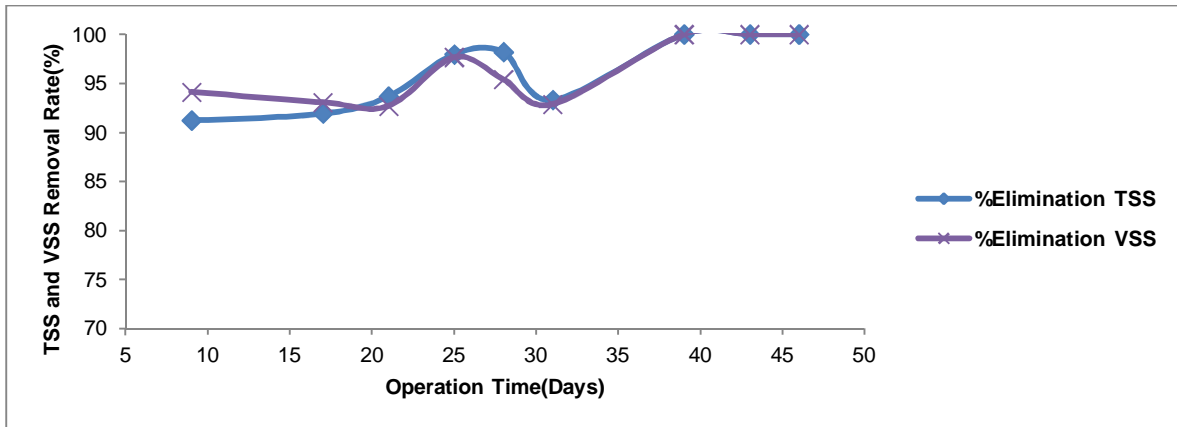

Figure 8. Removal Rate of TSS and VSS during operation time.

3.2 Accumulation region

The analysis for these parameters throughout operation time indicate different results according to the regions where the samples were taken. Figure 9 shows the regions of the membrane module where the samples were taken and its corresponding volume. Region 2 (named upper accumulation region) is the accumulation around the membrane (82.2L) and region 4 (named lower accumulation region) is the accumulation for the lower region of the membrane (8.1L).

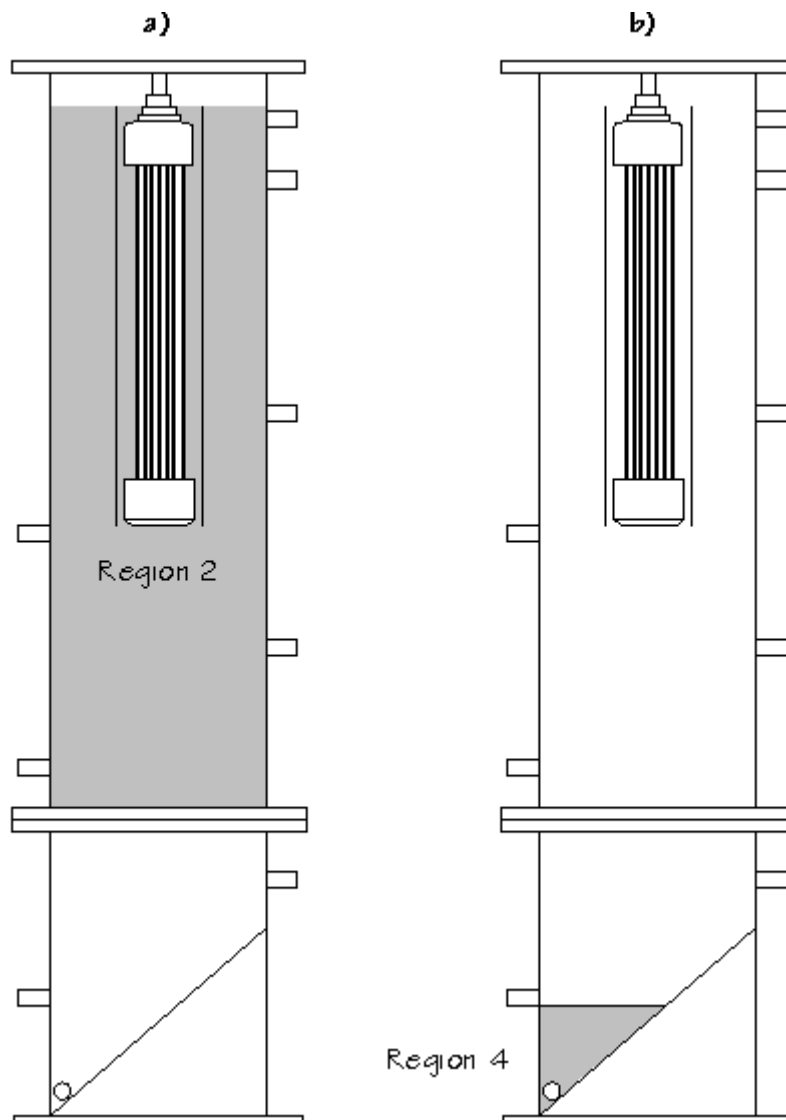

Figure 9. Accumulation Regions inside the module. Region 2 is the accumulation around the membrane (82.2L) and region 4 is the accumulation for the lower region of the membrane (8.1L).

3.2.1 τ COD and s COD

COD evaluation indicated an increase of the organic matter during the operation time (50 days). Figure 10 indicates the concentrations of COD and s COD from the upper and lower accumulated regions. The average τ COD value for the upper accumulated region was 6.85 gO₂/L, for the s COD 2.56 gO₂/L and at the lower accumulated region for τ COD 21.73 gO₂/L, for the s COD 2.73 O₂/L. The upper and accumulation region has an increase during operation time for the concentration of the particulated material. However this figure shows that there is a much higher concentration in the lower accumulated region.

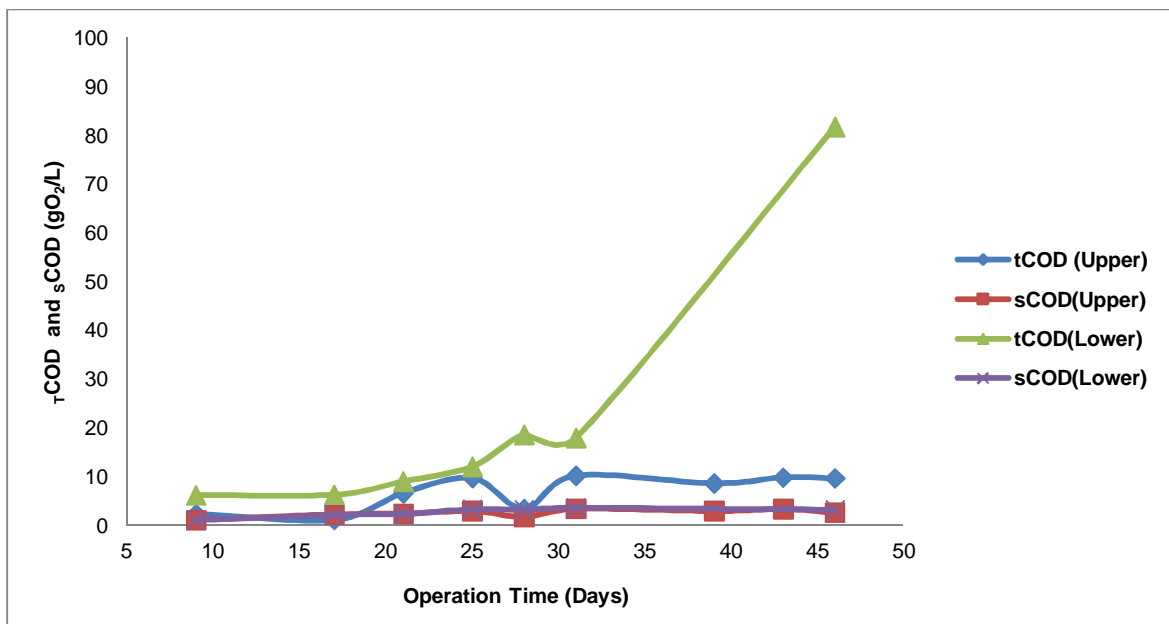

Figure 10. τ COD and s COD from the accumulated regions of the membrane module (upper and lower) during operation time.

3.2.2 TS, VS

Figure 11 indicates the concentrations of TS and VS from the upper and lower accumulated regions. The average TS value for the upper accumulated region was 3.39gTS/L, for the VS was 2.76gVS/L. The average TS value for the lower accumulated region was 11.25gTS/L, for the VS was 9.33 gVS/L. The purpose of this pretreatment focuses on separating two currents like described above, one for the permeated water and the other for the accumulation regions. Like shown in this figure, the solids from the lower accumulated regions have high concentrations. That's why the purpose is to take these (and the accumulated from the clarifier) to an anaerobic digestion at 35 °C. (mini-digesters from these regions were evaluated, explained later on).

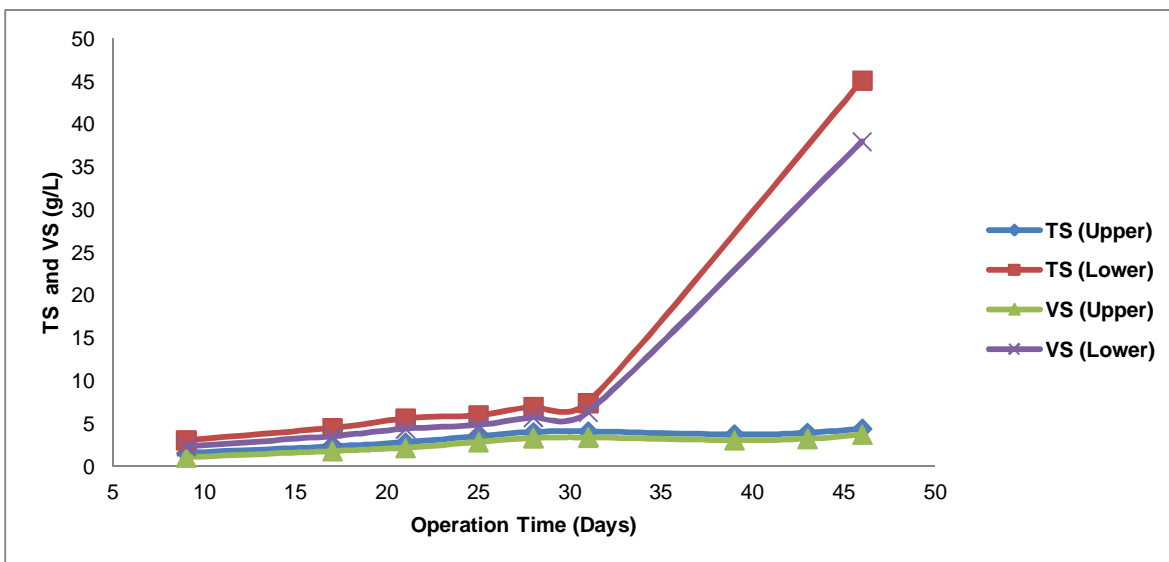

Figure 11. TS and VS from the accumulated regions of the membrane module (upper and lower) during operation time.

3.2.3 TSS and VSS

Figure 12 indicates the concentrations of TSS and VSS from the upper accumulated region of the membrane module. The average TSS value was 2.10gTSS/L, and 1.92gVSS/L.

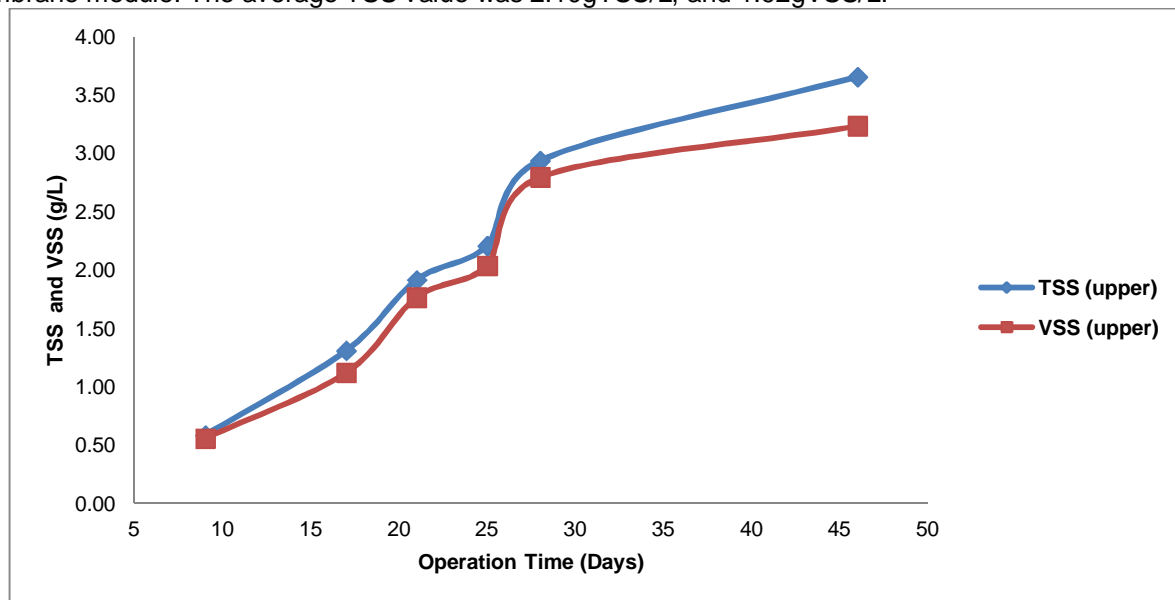

Figure 12. TSS and VSS from the upper accumulated region of the membrane module during operation time.

3.2.4 pH

Samples were taken from the central region of the membrane module and from the inflow weekly. The pH from the central region of the membrane module remained constant during the 50 days of operation in a range from 6.94 to 7.37. This small variation is due to the inflow which has a range from 6.9 to 7.81.

3.2.5 Particle Size

Samples were taken from the central region of the membrane module every 2 weeks. Figure 13 shows the graphs for size distribution for the 3 samples acquired. It shows that the particles' sizes stood around 0.5 μm of diameter. There has not been an important variation of the particle size although there has been turbulence on the central region of the membrane. Table 2 shows the results for each day a sample was taken. The particles with the same size of the membrane's pore (0.045 μm) could interfere during filtration of the wastewater and contribute even more to the fouling of the membrane. According to this table, there are no particles with such size. The smallest particle size recorded was 0.448 μm approximately.

Operation day	d(0.1) μm	d(0.5) μm	d(0.9) μm
17	0.473	0.660	1.463
39	0.544	0.780	2.079
50	0.538	0.747	1.716

Table 2. Particle's Size throughout operation time.

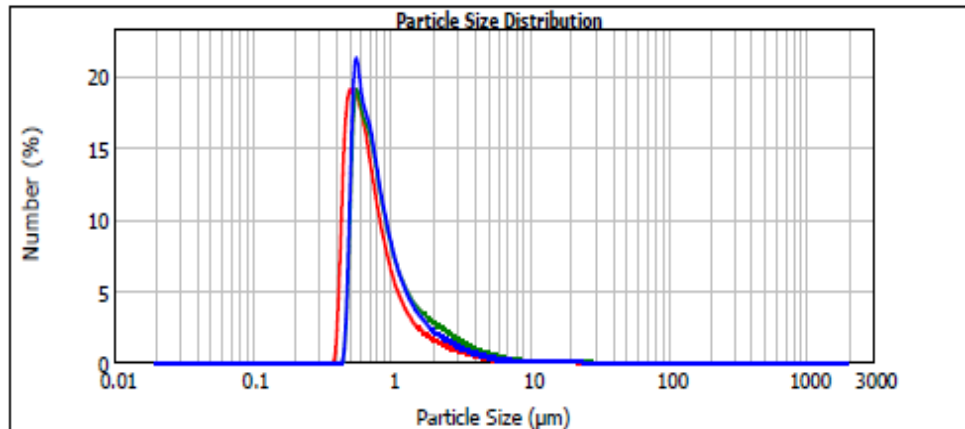

Figure 13. Particle size distribution during operation time.

3.2.6 TKN and NH_4^+

Samples were taken from the lower region of the membrane module (for days 39 and 46 of operation). Analyzing the concentrations of NH_4^+ and TKN is important because nitrogen and phosphorus encourage organic matter and algae growth which cause eutrophication (exhaustion of oxygen present in the water). As the algae die and decompose, high levels of organic matter and the decomposing organisms deplete the water of available oxygen, causing the death of other organisms. Figure 14 shows on day 39 the amount NH_4^+ is 0.19mg NH_4^+ /L while the amount of sTKN was 0.27g N/L, during day 46 it was 0.13g NH_4^+ /L and 0.26g N/L for the sTKN . Figure 15 shows a comparison of the sTKN and tTKN during the 46th day of operation. Results for tTKN and sTKN were 1.02 gN/L and 0.26gN/L respectively. This comparison leads to a conclusion that most TKN is present on the total phase of the sample.

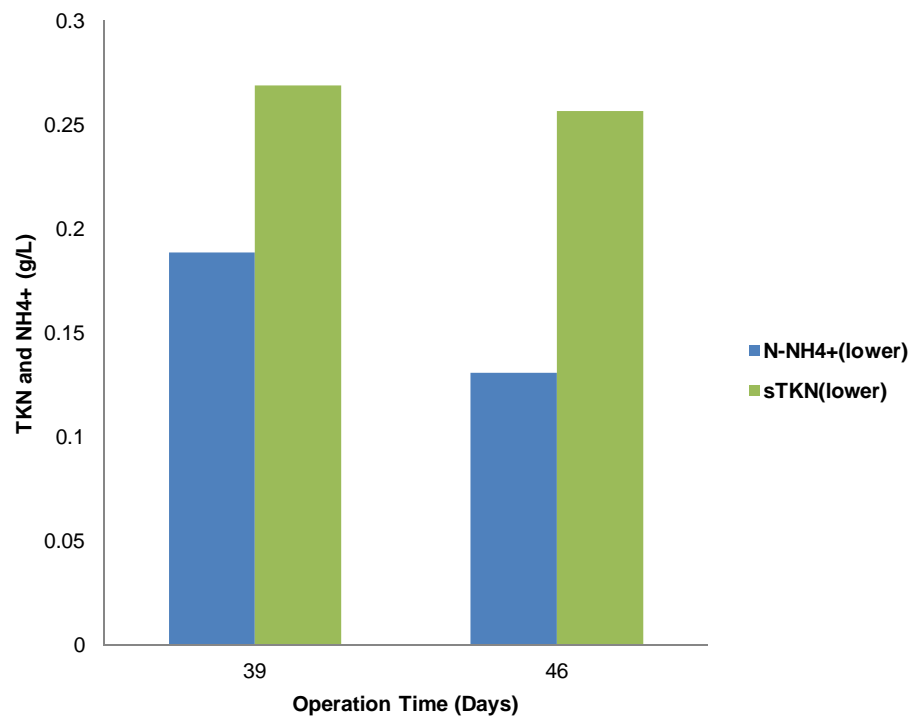

Figure 14. N-NH_4^+ and sTKN concentrations from the lower region of the membrane module during operation time.

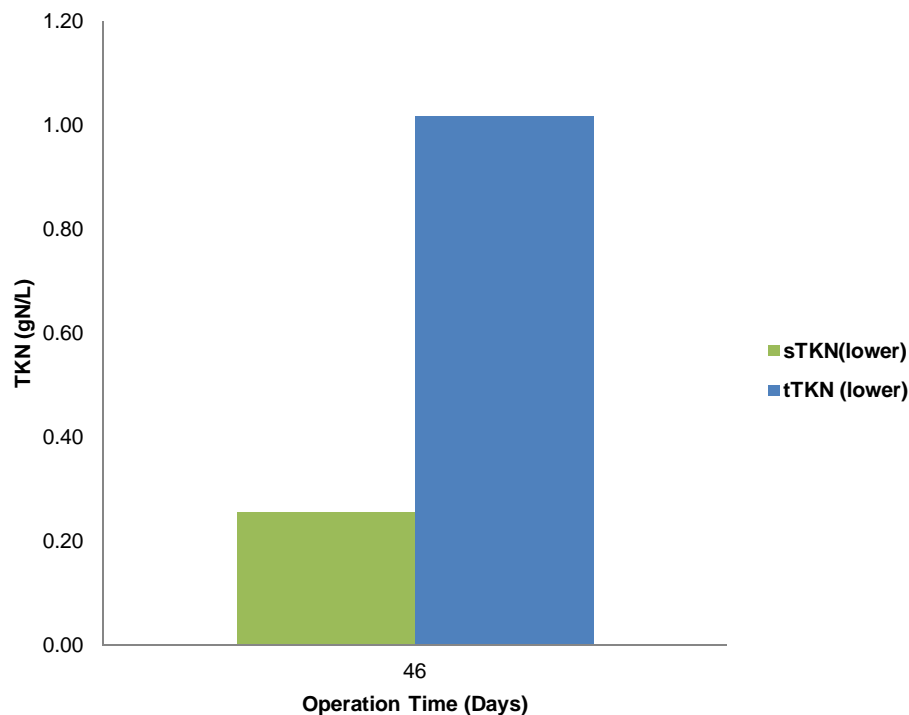

Figure 15. $sTKN$ and $tTKN$ comparison on the 46th day of operation from the lower region of the membrane module.

3.3 Volatile Fatty Acids

The process of anaerobic digestion on the acidogenic phase involves the production of a great amount of volatile fatty acids in the reactors which can lead to a serious inhibition of the methanogenic activity. The presence of VFAs in a sample matrix is often indicative of bacterial activity. (Siedlecka E.M. et al. 2008). Samples were taken on the 50th day of operation to analyze the concentrations of VFA's. As shown on Figure 16 the concentration of acetic acid is greater on the accumulated region of the module. The total concentration of VFAs is greater on the inflow than less in the upper accumulated region and even less on the permeate. Table 3 shows the concentration of each VFA according to the region.

Region	Concentration ppm									TOTAL
	Acetic	Propanic	Isobutyric	Butyric	Isovaleric	Valeric	Isocaproic	Hexanoic	Heptanoic	
Inflow	113.4	52.8	5.9	6.6	2.5	0.0	0.0	2.7	3.1	186.899
Upper Accumulated Region	177.896	0.000	0.310	0.000	0.000	0.000	0.000	0.000	0.000	178.207
Permeate	151.520	0.000	0.000	0.000	0.000	0.000	0.000	0.000	0.000	151.520

Table 3. Concentration of VFAs according to each region.

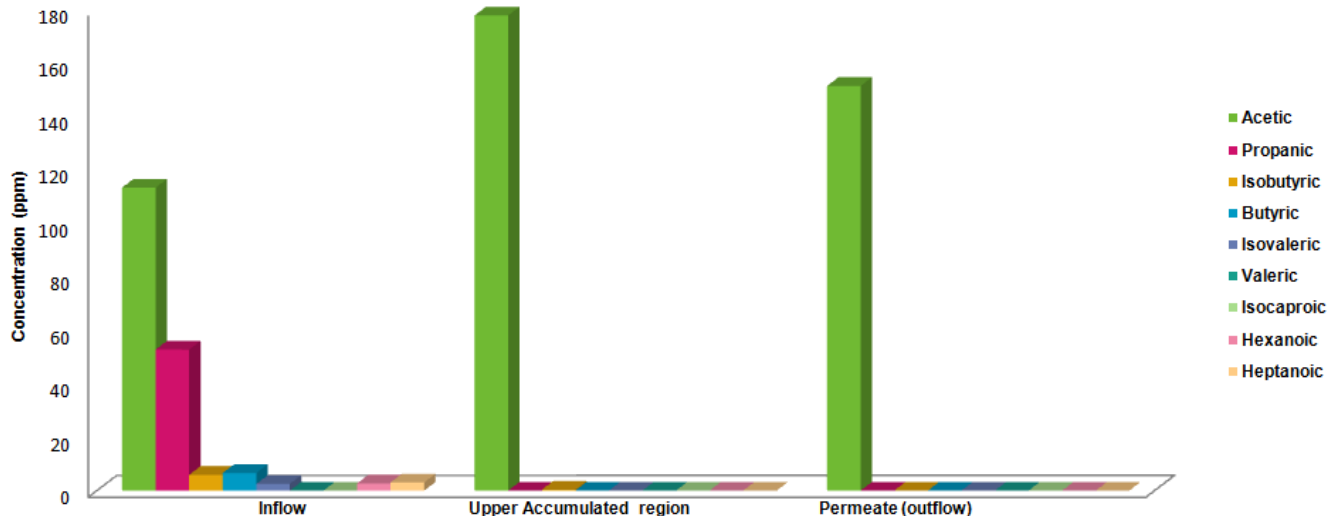

Figure 16. Volatile Fatty Acids from the 50th day of operation.

3.4 TMP

Figure 17 shows the evolution of the TMP of filtration (a) and backwash (b) obtained by the difference between the existent pressure of the gas chamber inside the membrane module and the filtration and backwashing pressure. Most of the time the pressure of the gas chamber was -10mbar. This is the value taken into consideration to calculate the TMP of filtration (a) and backwashing (b). With the program PicoLog Data Acquisition from Pico Technology® the evolution of the cycles was observed. TMP values increase during operation time caused by the increment of the solids around the membrane. It can be perceived that as the inflow is increased (filtration flow rate as well) the TMP values are gradually increasing. From day 1 to 25 with an inflow of 9L/h its corresponding filtration flux 10.11L/m²h, filtration cycle of 7.75min (backwash time (15s), relaxation (5s), filtration (7.5min.) and a pausing time (5s), and a velocity of the gas 54.57m/h the range for filtration TMP is 53.67 to 261.33 mbar. The range for backwashing TMP (with the same operation conditions) is -85 to 284.33 mbar. From day 27 to 41 the inflow increased to 11L/h, the filtration flux 13.44 L/m²h with the same filtration cycle and gas velocity the range for filtration TMP is 471.00 to 709.33 mbar. The range for backwashing TMP (with the same operation conditions) is 277.33 to 524.33mbar. From day 42 to 50 since the membrane reached excessive values of TMP the inflow was decreased back to 9L/h its corresponding filtration flux 10.11L/m²h, the filtration cycle was increased to 8.17min (increasing the backwash time to 30s), relaxation (5s), filtration (7.5min.) and a pausing time (5s), and a velocity of the gas was increased to 70.16m/h the range for filtration TMP is 498 to 587.67mbar. The range for backwashing TMP (with the same operation conditions) is 225.33 to 343.67mbar. During these last days it was expected to decrease the TMP's however the membrane was already too fouled. The concentration of solids inside the module increases as days pass by, that causes a greater difficulty for filtration and increasing the flow rate naturally makes filtration even more difficult. The conclusion is that TMPs increase by the higher solids concentrations in the interior of the module, which means that the membrane has a bigger barrier for the water to permeate.

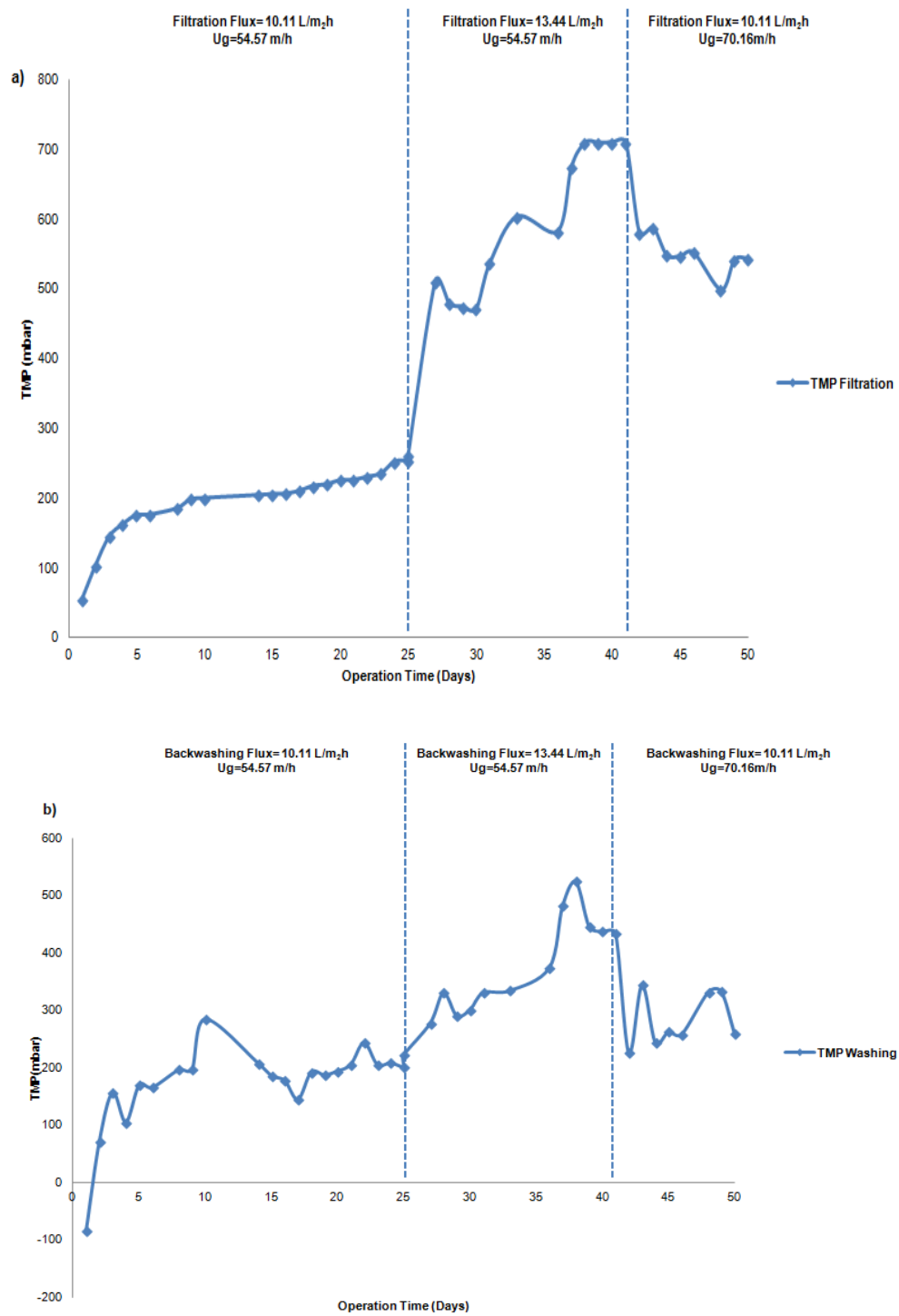

Figure 17. Filtration (a) and backwashing (b) TMPs during operation time.

3.5 Biodegradability of the accumulated solids

One of the most important parameters evaluated has been the biodegradability of the particulated accumulated material from the clarifier and the lower region of the membrane module. It was noted that starting the process of biologic degradation there is a high production of biogas. The explanation for this is that when the digestion starts there already is an easily digested part of the substrate resulting from organic matter with a more advanced stage of biodegradation (hydrolysis, acidogenesis, or acetogenesis) therefore increasing the methane production from methanogenic bacteria from the inoculum. As time passes, there is no organic material of high digestion and the solids would have to go through the three stages for biodegradation, which leads to a not so high slope interval as at the beginning, but later on a second rapid stage occurs followed by stabilization.

Figure 18 shows the Biodegradability of the accumulated solids from the lower region of the membrane module. It shows a rapid production of methane due to the particulated material of easy digestion at the beginning of the process. The most notable slope was produced during the first two days in which the mini digesters were prepared. To calculate the specific production of methane per VS the reached production during the 28th day of fermentation (100.24 mL of Methane) and the 0.4069gVS added from the substrate, 246.37 mLCH₄/gSV_{fed} was obtained.

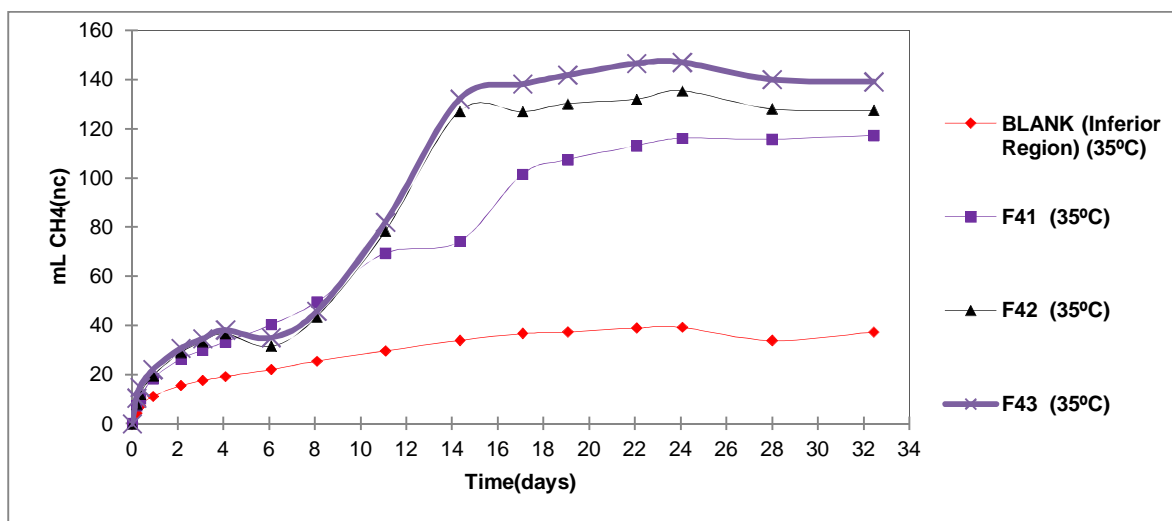

Figure 18. Methane production of the biodegradability test of the accumulated solids from the lower region of the membrane module.

Figure 19 shows the Biodegradability of the accumulated solids from the clarifier. It shows a rapid production of methane due to the particulate material of easy digestion at the beginning of the process. The most notable slope was produced during the first two days in which the mini digesters were prepared. To calculate the specific production of methane per VS the reached production during the 18th day of fermentation (105.64mL of Methane) and the 0.2712gVS added from the substrate, 389.48 mLCH₄/gSV_{fed} was obtained.

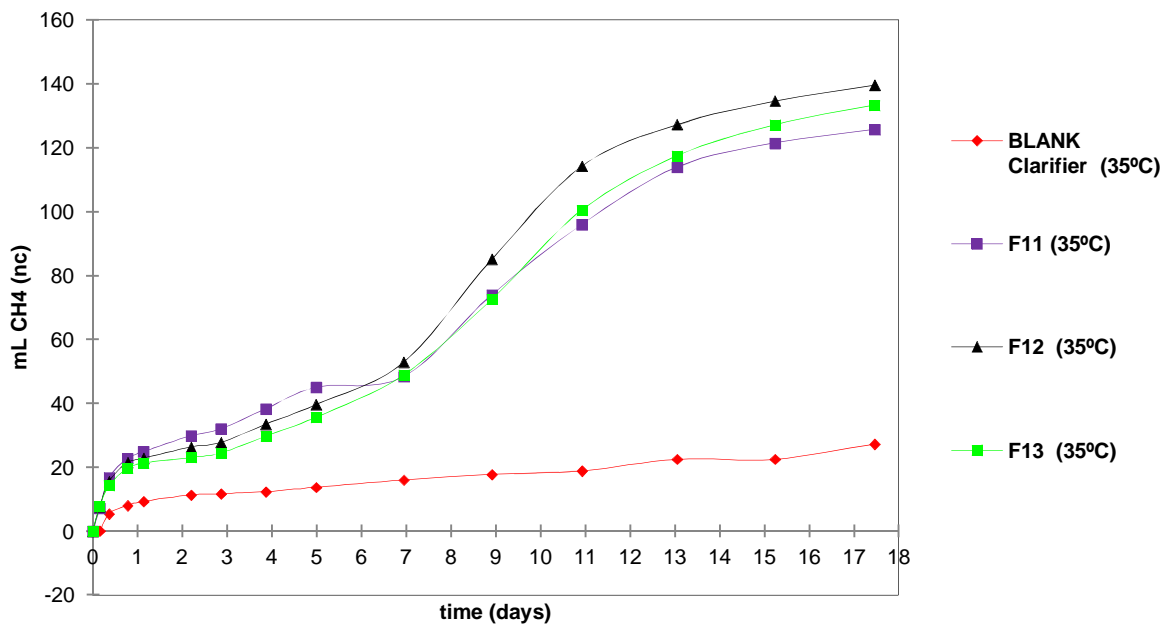

Figure 19. Methane production of the biodegradability test of the accumulated solids from the clarifier.

3.5 Membrane Cleaning and Permeability

Figure 20 shows the complete characterization of the membrane before and after the cleaning process. During this procedure the membrane characterization phases were first before and after physical cleaning and after chemical cleaning (which consisted in washing the membrane during four hours with 500ppm dissolution of Sodium Hypochlorite (NaOCl) at 18 °C. It is clearly shown that the TMP's improve through the chemical cleaning. The better the cleaning, less TMP needed to operate properly. Through each phase the membrane's permeability improves considerably. Before physical cleaning the permeability was 0.06(L/m²h) /mbar, after physical cleaning it was 0.08 (L/m²h) /mbar and after chemical cleaning it was 0.11 (L/m²h) /mbar.

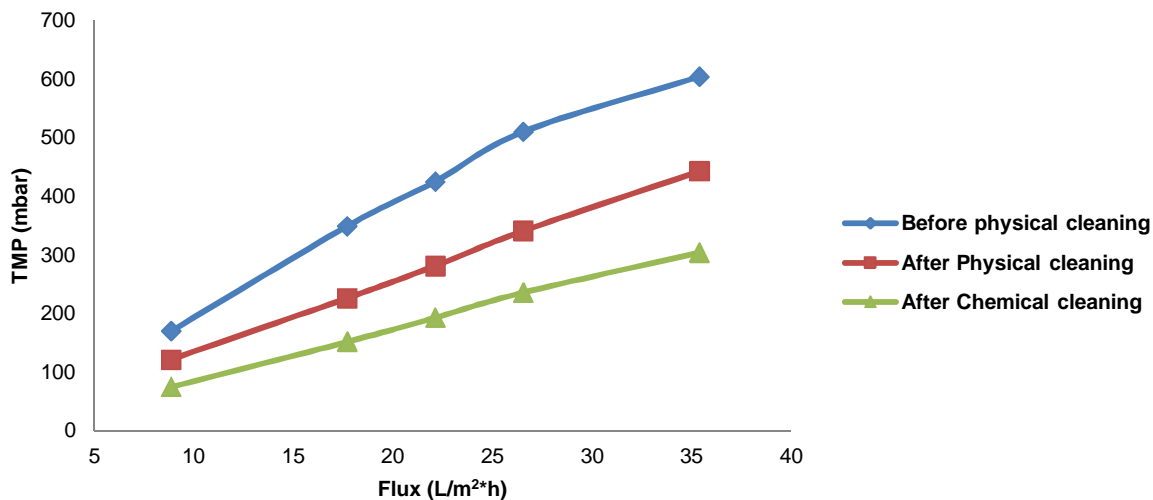

Figure 20. Influence of the chemical reagents used for washing on the recovery of the permeability of the membrane.

Figure 21 shows the complete characterization of the module after chemical cleaning with different reagents. First characterizing the membrane inside the module was made in order to determine the resistance of the cake. To characterize the membrane, it's taken out from the filtration module and it is characterized with tap water without physical cleaning. Then it is characterized after physical cleaning and finally it is characterized after the chemical cleanings. The chemical cleaning consisted on first washing the membrane's pores with 1000ppm dissolution of Sodium Hypochlorite (NaOCl) for three hours (changing the dissolution every hour) at 35 °C. To improve the cleaning, the membrane was put into a concentration of 0.3wt% of Ethylenediamine tetra-acetic acid (EDTA) for 30 min. at 38 °C. Since the results were not so efficient the concentration was increased to 0.8wt% for 2 hours at 40 °C (Regula C. et al. 2014). To complete the membrane cleaning another agent was used, 1wt% Citric Acid for 1 hour at 40 °C. Each characterization was made with tap water between 16 to 18 °C of temperature.

Inside the module before cleaning, the permeability was 0.03 (L/m²h) /mbar, before physical cleaning the permeability was 0.07(L/m²h) /mbar, after physical cleaning 0.08(L/m²h) /mbar, after chemical cleaning with NaOCl 0.17(L/m²h) /mbar, after using EDTA 0.27 (L/m²h) /mbar and after citric acid it was 0.31(L/m²h) /mbar. There is a notable increase of the permeability by using EDTA and after citric acid.

On Figure 23 the conditions of the fiber bundles of the membrane can be compared during the different phases of cleaning.

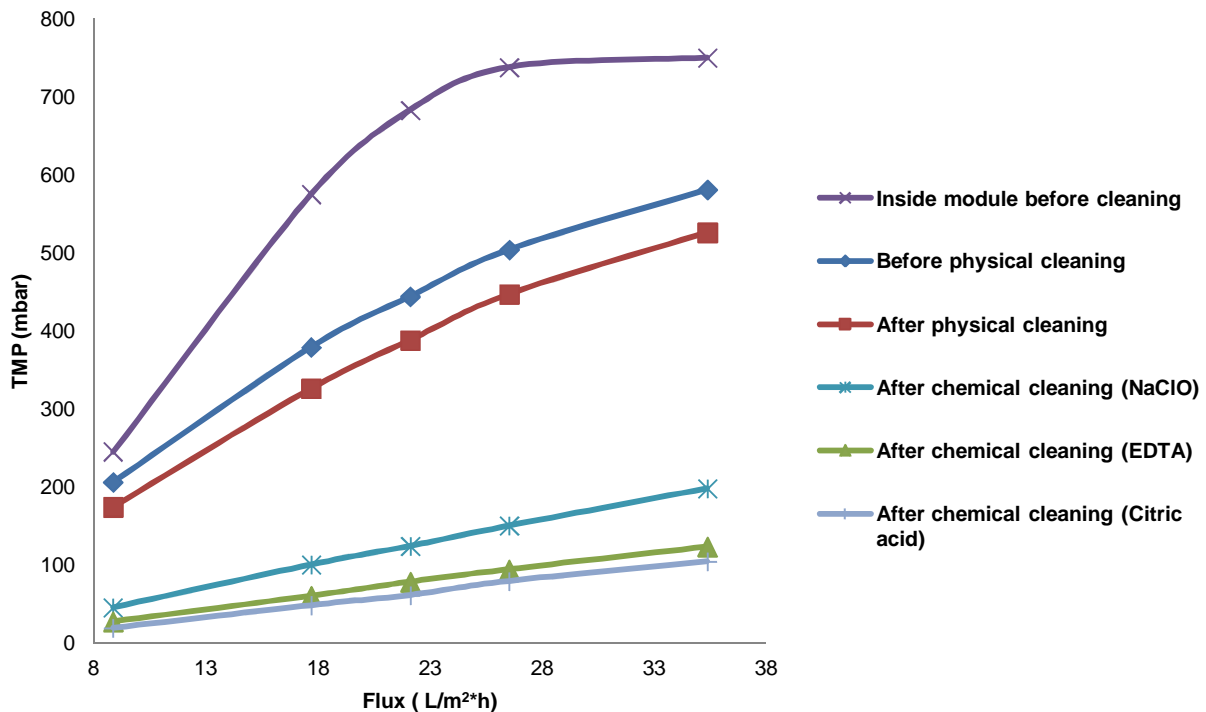

Figure 21. Membrane Characterization after experiment (Without cleaning inside and outside module, after physical cleaning, and after chemical cleaning with NaOCl, EDTA and citric acid.

Figure 22 shows the comparison between chemical cleaning using NaOCl under different conditions, one with a concentration of 500 ppm at 18 °C for four hours without changing the solution (reaches a permeability of 0.11 (L/m²h) /mbar) and the other with a concentration of 1000ppm at 35 °C changing the solution every hour for three hours (reaches a permeability of 0.17 (L/m²h) /mbar).

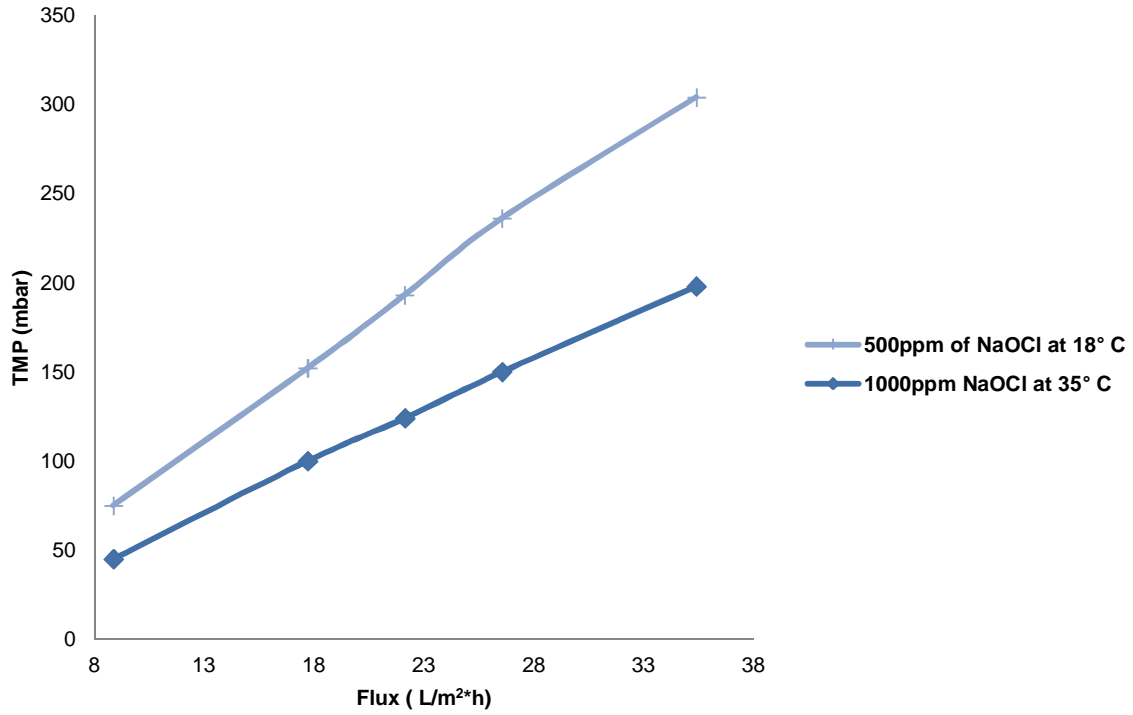

Figure 22. Comparison of using the same reagent (NaOCl) for chemical cleaning but with different conditions.

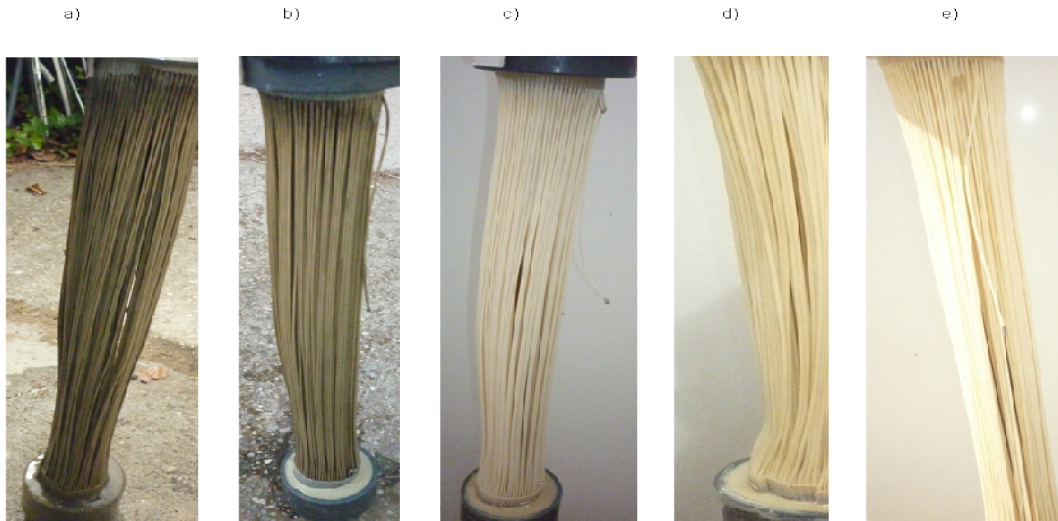

Figure 23. Membrane Fiber Bundle conditions from the characterization after experiment a) before cleaning, b) after physical cleaning, c) after chemical cleaning (NaOCl), d) after chemical cleaning (EDTA), and e) after chemical cleaning (Citric Acid).

Figure 24 shows a comparison of the membrane characterizations before and after experiment (50 days of operation with filtration fluxes from 9-13L/m²h) with a new membrane. It is notable that the membrane reaches less TMP values after the experiment although it was more fouled. The permeability of the membrane before starting the experiment was 0.11 (L/m²h) /mbar, after the experiment it was 0.31 (L/m²h) /mbar a new membrane 0.32 (L/m²h) /mbar. By using different agents and different conditions and temperatures the membrane after experiment had an organic removal of colloids and silicates and a destruction of pathogenic organisms with NaOCl. By using EDTA and citric acid mineral deposits were eliminated. Once a membrane is fouled during long-term operation, the original virgin membrane permeability is never recovered. There is a remaining resistance which can be defined as 'irrecoverable fouling', and it is not readily removed by typical chemical cleaning (Cai M. et al. 2009). It is also referred to as 'permanent fouling' or 'long-term irreversible fouling', which builds up over a number of years and might ultimately determine membrane life (Ayala D.F., et al. 2011).

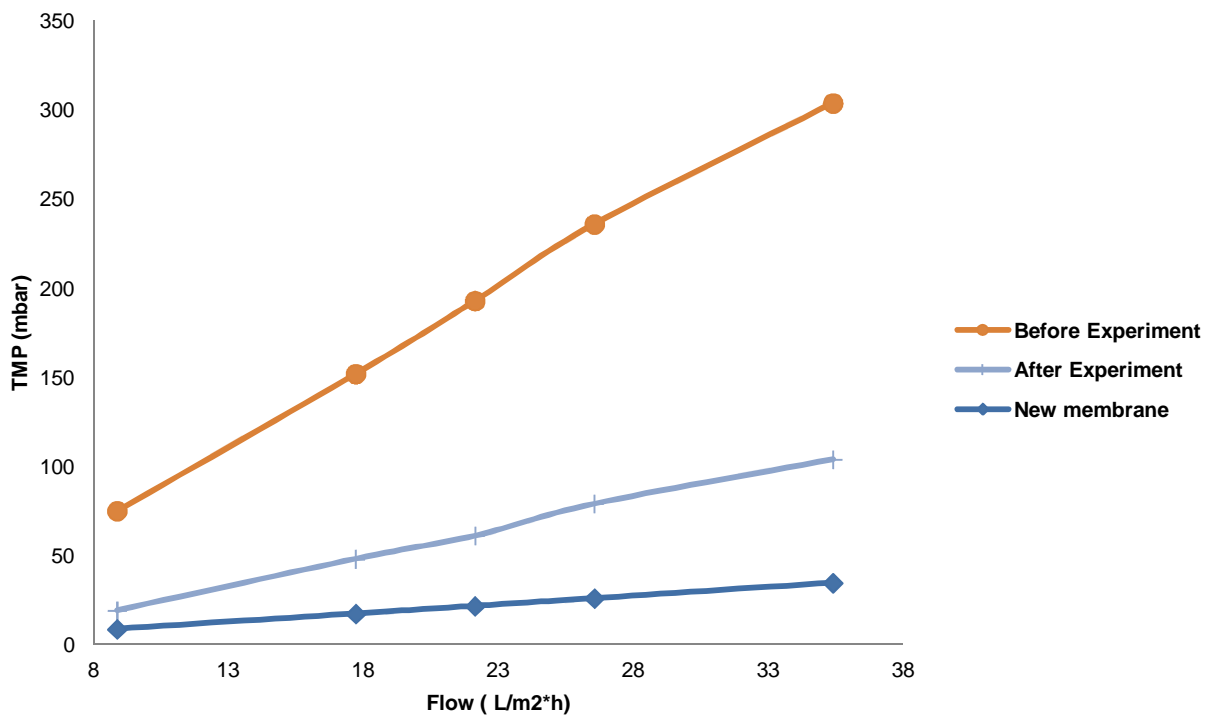

Figure 24. Comparison of the membrane characterization, before and after experiment with a new membrane.

4. Conclusions

Pretreatment of the urban wastewater with ultrafiltration membranes could be viable if it is operated with filtration fluxes from 9-10L/m²h, with filtration cycles of 8.17min (backwash time to (30s), relaxation (5s), filtration (7.5min.) and a pausing time (5s) and velocity of gas of 54.57m/h. With these conditions 100% of Suspended Solids are eliminated and 46.10% of the τ COD. The anaerobic biodegradability from the concentrated solids of the inferior region of the membrane has a specific production for methane of 246.37 mLCh₄/gVS_{fed}. The chemical cleaning with EDTA improves notably the chemical cleaning with NaOCl. Organic and inorganic matter was eliminated. The reached permeability of the membrane was 0.31 (L/m²h) /mbar while a new membrane has a permeability of 0.32 (L/m²h) /mbar.

Considering an inflow of 9L/h, filtration flux 10.11L/m²h, filtration cycle of 7.75min (backwash time (15s), relaxation (5s), filtration (7.5min.) and a pausing time (5s), a velocity of the gas 54.57m/h., τ COD of 9.75gO₂/L, s COD of 3.02gO₂/L and a concentration of 2.86gTS/L reached values of TMP for filtration and backwashing were 261.33mbar and 284mbar respectively. If the inflow was increased to 11L/h, the filtration flux 13.44 L/m²h with filtration cycle of 7.75min (backwash time (15s), relaxation (5s), filtration (7.5min.) and a pausing time (5s), a velocity of the gas 54.57m/h, τ COD of 10.23gO₂/L, s COD of 3.44gO₂/L and a concentration of total solids in the membrane region of 3.75 gTS/L a filtration TMP can oscillate between 500 to 700 mbar and 524 mbar for backwashing. With so high values of TMPs the filtration was affected. Therefore, the gas flow was increased so that the fiber bundles were unfouled from solid concentrations. However increasing the gas velocity to 70.16m/h, the backwash time to 30s and decreasing the inflow to 9L/h therefore the filtration flux (10.11L/m²h), τ COD of 9.86gO₂/L, s COD of 3.39gO₂/L and a concentration of total solids in the membrane region of 3.94 gTS/L the values for filtration TMP were still too high (600mbar aprox.) for the membrane to operate properly. The membrane cannot operate with inflows greater than 11l/h.

Acknowledgements

Acknowledgements to my Holy Father, God, my family and friends. To the company Cadagua and the members of the department of Chemical Engineering and Environmental Technology, from the University of Valladolid for allowing me to realize this investigation. Special acknowledgements to Doña María del Mar Peña Miranda for her excellent work as tutor.

References

APHA, Awwa, WEF, 2005, Standard Methods for the examination of Water and Wastewater, American Public Health Association, Washington, D.C., USA.

Ayala D.F., Ferre V., Judd S. J., Membrane life estimation in full-scale immersed membrane bioreactors, *J.Membr.Sci.*378(2011)95–100.

Cai M., Wang S., Zheng Y., Liang H. Effects of ultrasound on ultrafiltration of Radix astragalus extract and cleaning of fouled membrane, *Sep.Purif. Technol.*68 (2009)351–356.

Creus S. A.(2004). *Energías Renovables*, Cano Pina S.L.- Ediciones Ceysa.

EPA, United States Environmental Protection Agency (2007) Wastewater Management Fact Sheet Membrane Bioreactors water.epa.gov/scitech/wastetech/upload/2008_01_23_mtb_etfs_membrane-bioreactors.pdf. Last accessed July 16, 2014.

Heidrich, E.S., Curtis, T.P., Dolfing, J., 2011. Determination of the internal chemical energy of wastewater. *Environ. Sci. Technol.* 45, 827–832.

Henze M., Harremoës P., Jansen J., Arvin E., 2002. *Wastewater Treatment Biological and Chemical Processes*, Third Edition. Springer-Verlag Berlin Heidelberg, Germany.

Judd S., *The MBR Book: Principles and Applications of Membrane Bioreactors for water and Wastewater Treatment*, second edition, 2011.

Kan G., Cao Y. (2014) Application and modification of poly(vinylidene fluoride) (PVDF) membranes, *J Membrane Sci* 150, 149-155. DOI:10.1016/j.biortech.2013.09.111.

Lateef SK, Soh BZ, Kimura L (2013) Direct membrane filtration of municipal wastewater with chemically enhanced backwash for recovery of organic matter, *Bioresource Technol* 150:149–155. DOI:10.1016/j.biortech.2013.09.111.

Malvern Instruments, 2000. Mastersizer 2000: www.malvern.com/Assets/MRK501.pdf. Last accessed July 14, 2014.

McCarty, P.L., Bae, J., Kim, J., 2011. Domestic wastewater treatment as a net energy producer – can this be achieved? *Environ. Sci. Technol.* 45, 7100–7106.

Metcalf, Eddy, 2003. *Wastewater Engineering Treatment and Reuse*, 4th Edition. McGraw-Hill, New York.

Porcelli, N., Judd, S., 2010. Chemical cleaning of potable water membranes: a review. *Sep. Purif. Technol.* 71, 137–143.

Ravazzini, A.M., van Nieuwenhuijzen, A.F., van der Graaf, J.H.M.J., 2005. Direct ultrafiltration of municipal wastewater: comparison between filtration of raw sewage and primary clarifier effluent. *Desalination* 178, 51–62.

Regula C., Carretier E., Wyart Y., Gésan-Guiziou G., Vincent A., Boudot D., Moulin P.(2014) Chemical cleaning/disinfection and ageing of organic UF membranes, *Water Res* 56,325-365. DOI:10.1016/j.watres.2014.02.050.

Rittmann, B.E., McCarty, P.L., 2001. *Environmental Biotechnology: Principles and Applications*. McGraw-Hill, New York.

Siedlecka E. M., J. Kumirska, T. Ossowski, P. Glamowski, M. Gołębiowski, J. Gajdus, Z. Kaczyński, P. Stepnowski*(2008) Determination of Volatile Fatty Acids in Environmental Aqueous Samples, *Polish J. of Environ. Stud.* Vol. 17, (No. 3): 351-356.

Van Lier, J.B., 2008. High-rate anaerobic wastewater treatment: diversifying from end-of-the-pipe treatment to resource-oriented conversion techniques. *Water Sci. Technol.* 57 (8), 1137–1148.

Zhiwei W., Jinxing M., Chuyang Y.T., Katsuki K., Qiaoying W., Xiaomeng H., 2014, Membrane cleaning in membrane bioreactors: A review, *J MEMBRANE SCI*, 468, 276–307, DOI: 10.1016/j.memsci.2014.05.060.