

Smartphones as experimental tools to measure acoustical and mechanical properties of vibrating rods

This content has been downloaded from IOPscience. Please scroll down to see the full text.

2016 Eur. J. Phys. 37 045701

(<http://iopscience.iop.org/0143-0807/37/4/045701>)

View [the table of contents for this issue](#), or go to the [journal homepage](#) for more

Download details:

IP Address: 157.88.129.84

This content was downloaded on 20/04/2016 at 12:23

Please note that [terms and conditions apply](#).

Smartphones as experimental tools to measure acoustical and mechanical properties of vibrating rods

Manuel Á González¹ and Miguel Á González²

¹Departamento de Física Aplicada, E.I. Informática, Universidad de Valladolid, E-47011 Valladolid, Spain

²Departamento de Física de la Materia Condensada, E.I. Industriales, Universidad de Valladolid, E-47011 Valladolid, Spain

E-mail: manuelgd@termo.uva.es

Received 20 December 2015, revised 17 March 2016

Accepted for publication 31 March 2016

Published 20 April 2016



CrossMark

Abstract

Modern smartphones have calculation and sensor capabilities that make them suitable for use as versatile and reliable measurement devices in simple teaching experiments. In this work a smartphone is used, together with low cost materials, in an experiment to measure the frequencies emitted by vibrating rods of different materials, shapes and lengths. The results obtained with the smartphone have been compared with theoretical calculations and the agreement is good. Alternatively, physics students can perform the experiment described here and use their results to determine the dependencies of the obtained frequencies on the rod characteristics. In this way they will also practice research methods that they will probably use in their professional life.

Keywords: smartphone, experiment, active learning, autonomous work, motivation, vibrations, frequency analysis

(Some figures may appear in colour only in the online journal)

1. Introduction

While there is a general agreement on the importance of science, technology, engineering and mathematics (STEM) education in the productivity, economy and wealth creation of any country [1–3], shortages of students and teachers are an important issue in many countries. These shortages are specially important for physics and mathematics. In addition to these shortages there are other problems, such as the low percentage of girls opting for engineering or physics, as well as the increasing age gap between teachers and students. As a result,

different strategies are explored, both from institutions and individuals, to increase students' interest in STEM education and to obtain higher learning outcomes in science subjects. Between these strategies, teaching initiatives vary from the analysis of measurement tools and evaluation technologies [4] to the use of active learning techniques to increase students' interest and performance [5].

One of the active learning techniques for teaching physics that has grown in recent years is based on the use of students' smartphones as experimental tools in physics experiments. By using their smartphones, either in the teaching laboratory or outside it, even alongside everyday activities, students can observe nature in an autonomous way. In some recent works, with specific methods and on specific contents, using smartphones in physics teaching has proved to have positive learning and motivation outcomes with temporal stability for secondary school [6] and university students [7]. However, before generalizing the results described in those works, more research is required.

There are many published works describing experiments that can be performed using smartphones. These works can be broadly classified into three categories: adaptation of classical experiments in which some classical measurement devices are substituted or complemented with smartphones [8–14], low-cost experiments that, in many cases, can be done outside the laboratory [15–20], and experiments alongside students' everyday activities [21–27]. The mentioned papers are only some recent examples of these three categories and of the work done by different groups, but many more can be found in the bibliography. In this paper, we describe an example of the use of a smartphone to perform quantitative measurements of the sound produced when a rod with a fixed end vibrates. Only a smartphone and low cost elements are required to do this experiment. It can also substitute for more expensive arrangements in a traditional laboratory. To add a few more examples to the bibliography above, some recent works on acoustic measurements with a smartphone that may be of interest for the reader of this work can be found in [28–30]. On the other hand, some works on the study of vibration frequencies in rods with smartphones have been published recently. For example, [24] gives preliminary results showing the feasibility of such a study and also the good agreement that can be obtained between the theoretical results and the experimental data obtained with the smartphone. Later on, while this paper was under consideration for publication, [31] has been published on the same subject. This work [31] studies the resonant frequencies of rods clamped at different points with clothes pins.

Some characteristics of the students' experimental work with smartphones have proven to have a positive influence on the learning outcomes. For example in [6] the authors consider that the authenticity of the media has a positive impact on learning physics. This means that the students' learning and motivation are improved if they use in the laboratory the smartphones that they use every day (though for other activities) as experimental tools. Also, the simplification of the experimental arrangements when smartphones are used as standalone measurement devices may foster students' understanding [13]. About these positive results, one must add that doing physics experiments with their smartphones increases the students' autonomous work and their involvement in their own learning, while also helping them to learn experimental techniques that are required in the formal laboratory [6], such as the analysis of repeatability, limitations of the theoretical models, quantification of the experimental errors or accuracy of the experimental results.

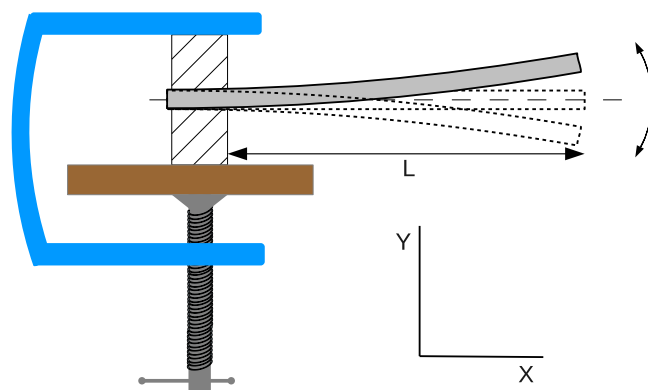

Figure 1. Rod undergoing transverse vibrations. Notice that the rod length, L , considered in the calculations corresponds only to the distance between the free end of the rod and the fixation point.

2. Theoretical background

A rod is a rigid body that is much larger along one dimension, its length, than along the other two. A rod can vibrate following longitudinal, transverse and torsional vibrations. Longitudinal vibrations appear if the rod is hit at one end along the direction of its axis and then it suffers compression and stretching vibrations, and torsion vibrations appear when the rod is twisted around its axis and then released. Transverse vibrations appear if one point of the rod, usually one end, is displaced perpendicularly to the rod length direction and released, as can be seen in figure 1. That figure shows a rod of length L , measured from the rod free end to the fixation point, undergoing transverse oscillations in an arrangement similar to the used in the work described in this paper.

Let us consider a rod with a fixed end that after an initial deformation in a direction perpendicular to its axis will follow transverse oscillations. Let us assume that the density of the rod is ρ and its Young's modulus E . We can consider, as will be the case in the experiments shown below, rods with circular section and radius r and rods with rectangular section and width w along the direction of the vibrations. Considering the X -axis to be the axis along the length of the rod, and that the Y -axis corresponds to the transversal direction along which the vibrations take place, then the movement of the rod obeys the differential equation

$$\left(\frac{\partial^2 y}{\partial x^2}\right) - \frac{1}{v^2} \left(\frac{\partial^2 y}{\partial t^2}\right) = 0. \quad (1)$$

The solution of (1) is of the type

$$y(x, t) = y(x, 0) \cos(2\pi ft + \phi), \quad (2)$$

so that each point x of the rod vibrates with amplitude $y(x, 0)$ and frequency f .

Considering the necessary boundary conditions of the movement, and assuming that there is no damping, the frequencies f of the vibrating rod obey [32]

$$f = \frac{vk}{L^2} C_n, \quad (3)$$

where

$$v = \sqrt{\frac{E}{\rho}} \quad (4)$$

is the speed of the sound in the rod, C_n is a number that establishes the mode of vibration

$$C_n = \frac{r_n^2}{2\pi} \quad (5)$$

$$r_n = (2n - 1) \frac{\pi}{2} \quad (6)$$

$$n = 1.097, 1.994, 3, 4, 5, \dots \quad (7)$$

and k is a parameter, equivalent to the radius of gyration of the cross-sectional area [32], that establishes the dependence of the frequency with the rod's section shape

$$\text{Rods with circular section: } k = \frac{r}{2}, \quad (8)$$

$$\text{Rods with rectangular section: } k = \frac{w}{\sqrt{12}}. \quad (9)$$

These solutions are obtained using numerical techniques from the transverse wave equation, taking into account the boundary conditions for the vibrating bar clamped at one end (see sections 3.8 to 3.11 of [32]). It is interesting to make students notice that, due to the boundary conditions, the possible vibration frequencies are limited to a discrete number of frequencies, but that for a vibrating rod, in contrast to the case of a string with fixed ends that students may know better, the vibrating modes are not multiples of the fundamental frequency, so that these are usually called inharmonic modes.

3. Experiment and results

The experiment described in this work consists of the measurement and analysis of the sound emitted by vibrating rods. By doing this experiment students can study the influence of different characteristics of the rods, such as their density, Young's modulus, length, shape and radius or width, on the frequencies of the emitted sound, and compare their results with the theoretical values that can be calculated from the expressions, equations (3) to (9), that can be found in the bibliography [32].

In this work we will only focus on the study of transversal vibrations of a rod with a fixed end. However, in order to propose broader experimental conditions to the students, rods of different materials and shapes are considered in the experiment, and the dependencies of the measured frequencies upon those parameters are analyzed and compared with the theoretical values. To measure the sound emitted by the vibrating rods we use a Samsung Galaxy S4 smartphone [33] and the application AudiA that can be freely downloaded from the Google Play store [34]. This application has been developed by our group [35, 36] and provides tools that allow students to perform different acoustics experiments. It also allows the smartphone to do the necessary frequency analysis by calculating the Fourier transform of the recorded sound. The calculation of this Fourier transform is perhaps the most demanding task that the smartphone must do in this experiment. For this, in order to allow for a fast and reliable numerical technique, the app AudiA uses an implementation of the Cooley–Tukey fast Fourier transform algorithm [37] as described in [38]. This app allows the user to export the measurement results and the Fourier analysis data by sending them as e-mail attachments or



Figure 2. Simple experimental arrangement necessary to study the vibrations of rods using a mobile device. In the figure, together with the vibrating rod a tablet recording the emitted sound is shown.

by saving the files in the smartphone. To send the files by email, the student must enter the email address to which the files are going to be sent before starting the measurements. If the files are saved in the smartphone, different formats can be chosen, but the most convenient for students is to save them as a csv file which, if necessary, can also be used later for data analysis or for obtaining a more precise Fourier transform in a computer. Another advantage of this app is that it also allows calibration of the smartphone microphone, so that the sound intensity measurements obtained with different smartphones can be compared. Anyway, this is not an important issue for this experiment as here we are not interested in the absolute values of the intensity, but in the frequencies of the relative maximum in the Fourier transform.

In order to study the dependence of vibration frequencies on the shape, length and material of a vibrating rod, we have used in this experiment steel and aluminium rods with rectangular and circular sections of different thicknesses (measured along the direction of the vibration) or radii. All the results shown in this work correspond to smooth rods, as we have observed that for threaded rods the results require more complex and difficult interpretation. The rods used in the experiments described in this paper correspond to several different steel alloys rods with lengths $l_s = 0.25, 0.35, 0.45, 0.50, 0.55, 0.70$ and 0.90 m and circular sections of radius $r = 0.0009, 0.0015, 0.002, 0.003$ and 0.004 m, and aluminium alloy rods of lengths $l = 0.50, 0.70$ and 0.90 m, with square section with widths $w = 0.002, 0.006$ and 0.008 m. To hold the fixed end of the vibrating rod only two wooden blocks and a C-clamp are necessary, as shown in figure 2, together with a device used to record the measurements. As can be seen in that figure, the vibrating length of the rod that must be considered is the distance from the fixing point to the free end of the rod. Then, that length must be measured once the arrangement is set, and the same rod can be used to study the influence of the rod length on the vibration frequencies by fixing the rod at different points. A previous check, placing the smartphone or tablet at different distances from the vibrating rod, must be done before recording the measurements, in order to ensure that its microphone receives enough sound intensity but not so large that it is saturated.

Once the rod is clamped between the wooden blocks we start the vibration by pushing and releasing its free end vertically. Students must take care not to touch the rods once the vibration has started in order to record unperturbed vibrations. The sound recording with the smartphone application can be started shortly before releasing the rod in order to better

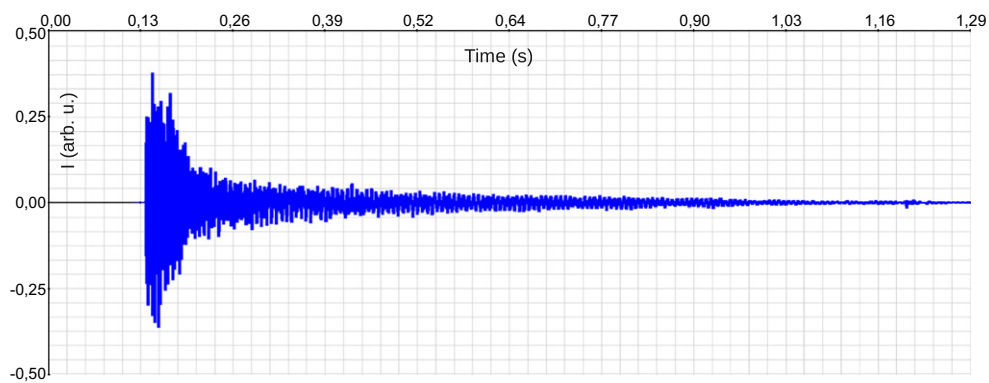

Figure 3. Screenshot of the application AudiA with an example of the recorded sound of a vibrating rod.

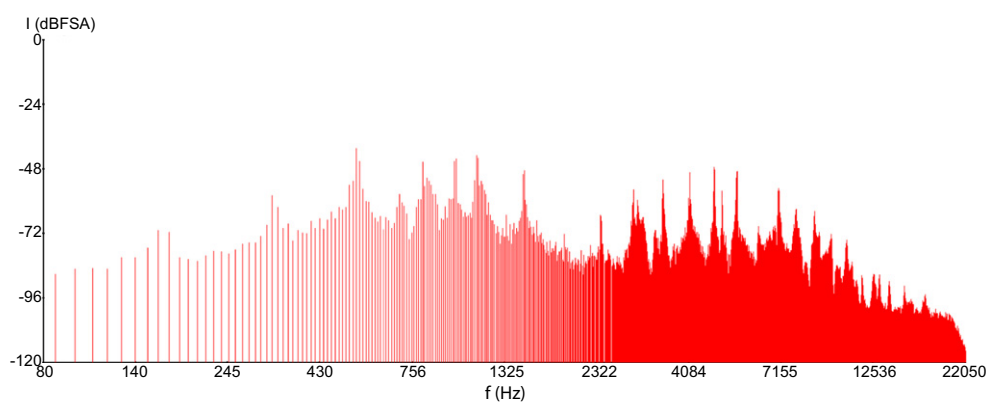

Figure 4. Screenshot of the application AudiA showing the Fourier transform of the sound shown in figure 3. In this figure the intensity is given in decibels full scale (dBFS) and the frequency in Hertz (Hz).

acquire the vibration sound. To obtain better experimental results, students must also take special care not to make any noise while the sound is recorded. Figure 3 shows an example of the sound recorded with the application for a vibrating rod.

Independently of a possible analysis of the exported file done later using a computer, students can calculate the Fourier transform of the recorded sound with the mobile application AudiA, as we have done in this work. An example of such analysis is shown in figure 4, where a screenshot of the smartphone displaying the calculated Fourier transform is shown. As can be seen in that figure, the peaks corresponding to the overtones of the vibrating rod can be clearly distinguished. In figure 4 sound intensity is given in dBFS. The app AudiA allows users to store the measurements using different units, and here dBFS are used so that students can also possibly notice the influence of A-weighting in sound measurements. Decibels relative to full scale (dBFS) measure decibel amplitude levels in digital systems with maximum available peak level to which the 0 dBFS value is assigned. In many sound measurements, for example in noise measurements, it is useful to consider the relative loudness perceived by the human ear. For this, the recorded sound is weighted according to a

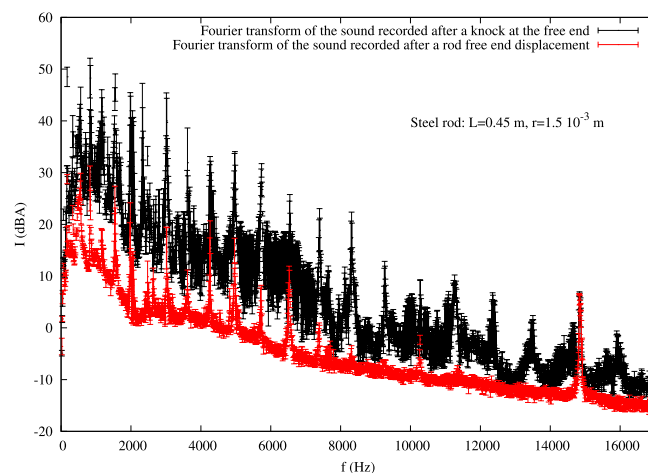

Figure 5. Comparison of the average Fourier transform obtained by starting the vibrations either displacing and releasing the free end of the rod or by knocking it. In this figure the intensity is given in absolute decibels (dBA) and the frequency in Hertz (Hz).

family of curves, with A-weighting being the most commonly used curve defined in the International Standard IEC 61672:2003. Then, when the measurements are A-weighted, the final ‘A’ is added to the employed units. On the other hand, in order to analyze the influence of the smartphone microphone quality on the measurements, mainly at high frequencies, we have also performed measurements with smartphones with microphones of different quality. We have observed that lower quality microphones are much less sensitive to higher frequencies, so that the corresponding modes are much more difficult to detect, and in some cases even the Fourier transform curves obtained with them show nearly constant values of very low intensity for the higher frequencies.

As an alternative method, instead of starting the rod vibration by displacing and releasing its free end, students can also carefully knock it at the free end, trying to apply a force as perpendicular as possible to the rod axis. According to our own results, this method allows users to record higher frequency overtones but can also excite other non-transversal vibration modes. Then, the calculated Fourier transform obtained in this way exhibits a higher number of modes, mainly at high frequencies, than those obtained when the rod is displaced and released, but also shows higher experimental noise, as can be seen in figure 5. In that figure two averaged Fourier transforms are shown with error bars. Each of those averages is obtained from three independent experiments in which the vibration is started after either an initial displacement and releasing or after knocking the rod end. The measurements shown in figure 5 correspond to a steel rod with circular section and radius $r = 1.5 \cdot 10^{-3}$ m and length $L = 0.45$ m.

In order to have an estimation of the influence of the experimental noise on the results, figure 5 shows the Fourier transform average values with error bars for each case, displacing or knocking the rod. As for most experimental works, it would then be advisable for students to repeat each experiment several times in order to quantify, and reduce if possible, the experimental noise. The reader can also observe in figure 5 how the intensity decreases as the frequency increases. This effect, together with the experimental noise, increases the difficulty of an accurate determination of the values of the high frequency overtones, as the peaks

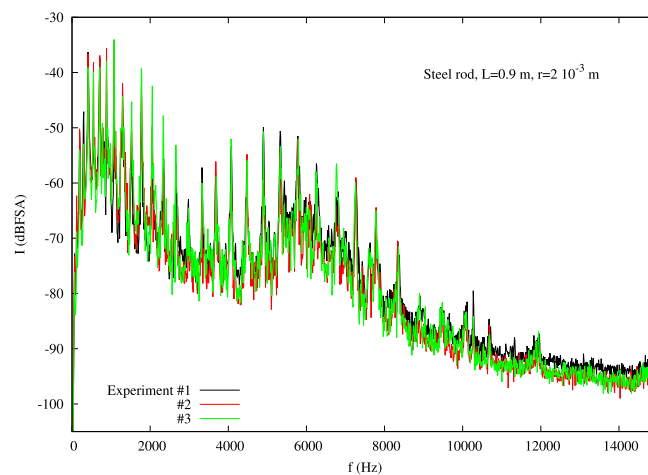

Figure 6. Comparison of the Fourier transform obtained from three independent measurements of the vibrations of a $L = 0.9$ m long steel rod. In this figure the intensity is given in decibels full scale (dBFS) and the frequency in Hertz (Hz).

become less sharp and can be blurred by the experimental noise. At low frequencies, below approximately 100 Hz, some frequencies may pass undetected as many current smartphones' microphones have working ranges between about, approximately, 80 Hz and 18 kHz. These limits depend on the smartphone used in the experiment and some data are discussed, for example, in [39].

On the other hand, even for the noisier conditions, the Fourier transform calculated shows high repeatability, which is remarkable considering the simple experimental arrangement and large range of frequencies studied in the experiment, as well as the sound recording and Fourier transform calculation using a smartphone. In figure 6, the results of three measurements under the same conditions are shown together to illustrate the repeatability of the frequency values and intensities obtained with the Fourier transform in the smartphone. Data shown in that figure correspond to a 0.9 m long steel rod with circular section of radius $2 \cdot 10^{-3}$ m.

From the Fourier transform obtained using the application AudiA with the smartphone, or by using any other sound analysis software in a computer, students can detect easily the vibration frequencies of each rod. These frequencies correspond to the relative maxima in the Fourier transform. Then, a comparison with the theoretical expressions (3) to (9) allows students to check the accuracy of the theoretical model and experimental results, as well as to study the influence of different parameters on the vibration frequencies. Figure 7 shows the comparison of the experimental frequencies and the theoretical values calculated using expressions (3) to (9). The experimental results shown in figure 7 correspond to an average of the Fourier transforms of three independent measurements of the vibrations of a steel rod with length $L = 0.35$ m and cylindrical section of radius $r = 0.925 \cdot 10^{-3}$ m. For the calculation of theoretical values, the Young's modulus and density values were taken from [40]. As can be seen in the figure, in spite of the single arrangement, large ranges of frequencies considered, and the use of only one smartphone, the agreement between experimental data and theoretical values is reasonably good.

However, the good agreement shown in figure 7 strongly relies not only on the quality of the experimental data and of the Fourier transform calculation, but equally depends on how

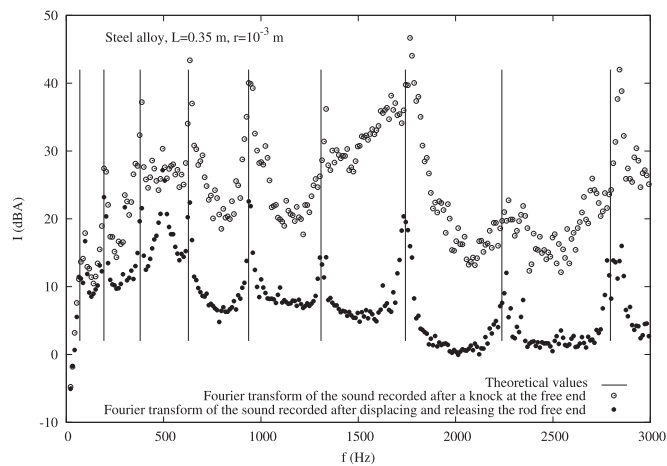

Figure 7. Comparison between experimental frequencies and theoretical values. In this figure the intensity is given in absolute decibels (dBA) and the frequency in Hertz (Hz).

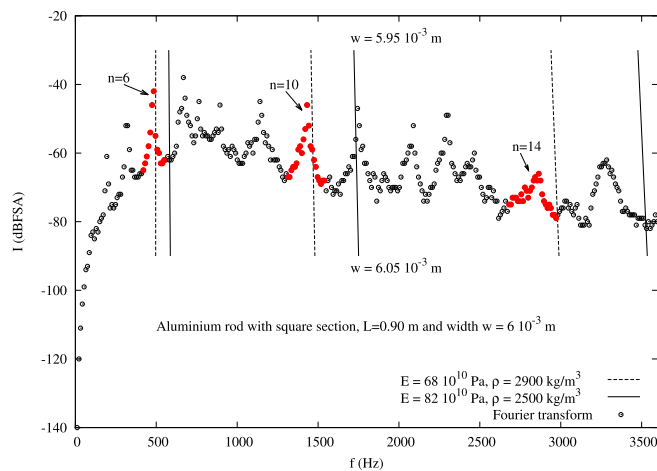

Figure 8. Comparison between experimental frequencies and theoretical values for only three modes in an experiment with a vibrating Al rod. The studied modes are shown with full (red) circles while the rest of the modes are shown using open (black) circles. The maximum and minimum values of the calculated frequencies, depending on the material characteristics, are represented with vertical continuous and dashed lines, respectively. The influence of an inaccuracy in the rod width is also considered by analyzing the change in the theoretical values if the width is $w = 5.95 \cdot 10^{-3}$ m or $w = 6.05 \cdot 10^{-3}$ m instead of $w = 6$ mm as stated in the rod specifications. In this figure the intensity is given in absolute decibels (dbFSA) and the frequency in Hertz (Hz).

well the rod material is characterized. This means not only quantities that the student can measure, such as the length and the radius or the width of the rod, but also on how accurate our knowledge is of other properties, such as its Young's modulus, E , or density, ρ , that establish the speed of sound in the material, as shown in equation (4), and then determine the frequencies of the vibrating rod through equation (3). Figure 8 shows an example of what can

happen when some of the above-mentioned parameters are not accurately known. In that figure the average Fourier transform of the sound emitted by an aluminium rod is shown with dots. The rod in this example has square section with side $w = 6 \cdot 10^{-3}$ m, according to the vendor specifications, and in this experiment we had a vibrating length $L = 0.90$ m. According to the data in [40], depending on the rod aluminium alloy its Young's modulus can range between $E = 68 \cdot 10^9$ Pa and $E = 82 \cdot 10^9$ Pa, and its density between $\rho = 2500$ kg m^{-3} and $\rho = 2900$ kg m^{-3} . Then, considering these data, the speed of the sound in equation (4) can take values between $v \approx 4.84 \cdot 10^3$ m s^{-1} and $v \approx 5.73 \cdot 10^3$ m s^{-1} , assuming that E and ρ are independent variables. As the speed of sound appears in equation (3) as a multiplying factor, the lack of precision in the data of the rod material induces a larger inaccuracy in the theoretical values of the frequencies of the modes of higher order. This can be seen in figure 8. In that figure the agreement between the experiment and calculations for only three modes is analyzed. The considered modes, corresponding to $n = 6, 10$ and 14 in equation (7), have experimental frequencies around 484, 1430 and 2827 Hz, and are marked with red full dots in the figure. The maximum and minimum values of the theoretical frequencies corresponding to those modes were calculated using equations (3) to (9) using the maximum and minimum values of the sound speed given above, and are represented in figure 8 with straight lines: a dashed line for the minimum and a full line for the maximum theoretical frequency of each mode. The influence on those values of a possible inaccuracy of the rod width is also shown. For this, two close values of the width were considered instead of the $w = 6 \cdot 10^{-3}$ m stated by the manufacturer: $w = 5.95 \cdot 10^{-3}$ m and $w = 6.05 \cdot 10^{-3}$ m. To represent the influence of the inaccuracy of the rod width on the calculated frequencies the lower end of the theoretical lines were obtained for a value of width $w = 6.05 \cdot 10^{-3}$ m, and the upper value of those lines for a value $w = 5.95 \cdot 10^{-3}$ m, so that those lines show a leftwards inclination. As can be seen in that figure the inaccuracy due to the lack of an exact knowledge of the material properties increases with increasing mode, becoming very large for high order modes. Even a very small change in the width of the rod is also noticeable, as the theoretical values for the higher width (bottom of the theoretical straight lines) are noticeably larger than the ones corresponding to the lower value of the width (top of the theoretical straight lines).

However, from a teaching point of view, this disadvantage can be turned into an advantage if students are suggested to discuss the quality of the rod, or to investigate its density or Young's modulus from the discrepancies between the experimental and calculated values of the frequencies. When there are not reliable data on the rod characteristics the students can also follow an alternative method. Instead of comparing the experimental and theoretical results, they can also try to obtain the dependencies of frequencies on the rod characteristics, such as its length, radius or width. For example, figure 9 shows, using a logarithmic scale, the dependence of the frequency of the third vibration mode, taken as an example for this calculation, measured directly on the Fourier transforms calculated from the vibrations of rods with different materials (steel and aluminium), sections (circular and rectangular) and rod radius or width. As can be seen there, in spite of the experimental noise, the average slope of the fittings of the experimental data for all those cases is $m = -1.93 \pm 0.07$, which agrees well with the expected theoretical slope $m = -2.00$.

In the same way, figure 10 shows the results of the study of the dependence of the third mode experimental frequency on the radius or width of rods of different lengths. As can be seen in that figure, the fitting of the experimental data for such different cases also agrees well with the expected theoretical dependence.

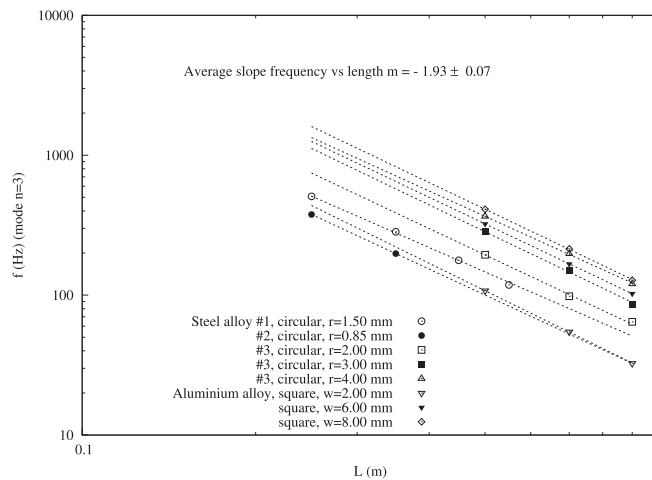

Figure 9. Determination of the dependence of the vibration frequencies upon the length of the rods. For this analysis, students can compare the results obtained with rods of different materials and shapes.

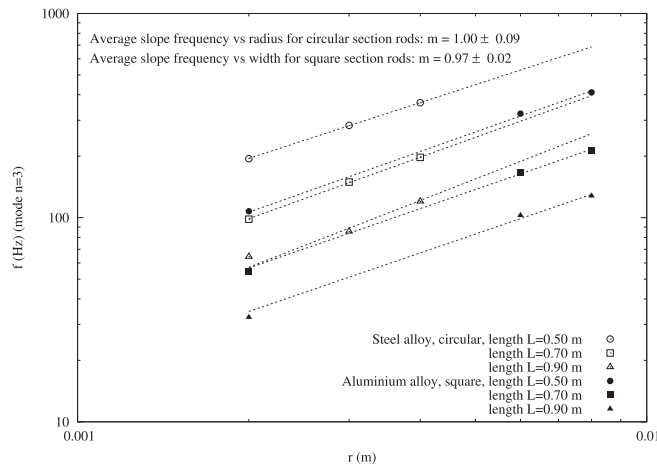

Figure 10. Determination of the dependence of the vibration frequencies on the radius for circular sections, or width for rectangular sections, of the rods.

4. Conclusions

In this work we have shown how smartphones can be applied to measure and analyze, using usual Fourier analysis techniques, the sound emitted by vibrating rods with a free end. We have seen that, due to technical limitations in current smartphone microphones, frequencies below approximately 100 Hz cannot be recorded well. On the other hand, for high frequencies, as their intensities are lower, the influence of experimental noise and inaccuracies is higher, which can increase the difficulty in the determination of the frequency of those overtones. Also, the microphone quality can affect the quality of the measurements at high frequencies, so that we recommend to limit the study to a range of not too high frequencies.

The experimental method has proven to be highly repeatable, which increases the accuracy of the calculated average results. We have also discussed some sources of discrepancies between the experimental and theoretical results, such as the uncertainties in the rod characteristics. We have observed generally good agreement between the experimental and theoretical frequencies for rods of different materials and shapes if the rods are well characterized. This result confirms the utility of smartphones and the reliability of the measurements and calculations done using the application AudiA.

From the teaching point of view, we have shown that smartphones, together with cheap and easy to acquire experimental elements, allow students to perform acoustics measurements and analysis of quality. This allows us to think of this as a low-cost experiment that can be performed either in a teaching laboratory or even at students' homes. Students can use this experimental arrangement to learn by themselves and study the influence of the rod shape and material on the measured frequencies. In fact, this experiment will be proposed to our engineering students at the university during the next term, and all teaching materials and their learning outcomes will be also publicized. On the other hand, this experiment can also be useful to teach students how the analysis and interpretation of the results in any experimental work are limited due to either the characteristics of the experimental material, the experimental method and noise, or even the mathematical and numerical tools used in the analysis.

The next step in this work is to analyze the learning outcomes of the students when they use their smartphones in physics experiments. To obtain significant learning analytics results the work and results of a significant number of students must be analyzed, also studying, if possible, the influence of different learning levels and environments. For this large work the collaboration of professors from different institutions and levels may be a necessary starting point. From the work with our own students, qualitative results show that the students' interest in physics and their engagement increase when working with smartphones and applications.

Finally, as with many other experiments that can be done with students' own smartphones, the work described in this paper illustrates how smartphones, which nearly all of our students have in their pockets, can become very useful learning tools by allowing them to learn physics by themselves, observing and measuring physical quantities of different complexity with enough accuracy nearly anytime and anywhere, which can improve their learning by confronting their knowledge with the observations made with their, always within reach, mobile devices.

Acknowledgments

The authors thank the University of Valladolid for its support to this work under grants PID2015_128 and PID2015_129.

References

- [1] Carter L 2008 *J. Res. Sci. Teach.* **45** 617–33
- [2] Snyder T D and Dillow S A 2012 *Digest of Education Statistics 2012* (Washington, DC: Washington National Center for Education Statistics, US Department of Education)
- [3] Marginson S, Tytler R, Freeman B and Roberts K 2013 *STEM: Country Comparisons* (Melbourne: Australian Council of Learned Academies)
- [4] Saxton E, Burns R, Holveck S, Kelley S, Prince D, Rigelman N and Skinner E A 2014 *Stud. Educ. Eval.* **40** 18–35

- [5] Freeman S, Eddy S L, McDonough M, Smith M K, Okoroafor N, Jordt H and Wenderoth M P 2014 *Proc. Natl Acad. Sci.* **111** 8410–5
- [6] Kuhn J and Vogt P 2015 *Multidisciplinary Research on Teaching and Learning* (Basingstoke: Palgrave MacMillan) pp 253–69
- [7] Klein P, Kuhn J, Müller A and Gröber S 2014 *Multidisciplinary Research on Teaching and Learning* (Basingstoke: Palgrave MacMillan) pp 270–88
- [8] Castro-Palacio J C, Velázquez-Abad L, Giménez M H and Monsoriu J A 2013 *Am. J. Phys.* **81** 472–5
- [9] Castro-Palacio J C, Velázquez-Abad L, Giménez F and Monsoriu J A 2013 *Eur. J. Phys.* **34** 737–44
- [10] Sans J A, Pereira A L J, Gómez-Tejedor J A and Monsoriu J A 2013 *Eur. J. Phys.* **34** 1349–54
- [11] Gómez-Tejedor J A, Castro-Palacio J C and Monsoriu J A 2014 *Eur. J. Phys.* **35** 025006
- [12] Gröber S, Molz A and Kuhn J 2014 *Eur. J. Phys.* **35** 065001
- [13] Klein P, Hirth M, Gröber S, Kuhn J and Müller A 2014 *Phys. Educ.* **49** 412–8
- [14] Wei M, Huang S, Wang J, Li H, Yang H and Wang S 2015 *Eur. J. Phys.* **36** 065026
- [15] Briggles J 2013 *Phys. Educ.* **48** 285–8
- [16] Monteiro M, Cabeza C and Martí A C 2014 *Eur. J. Phys.* **35** 045013
- [17] Parolin S O and Pezzi G 2015 *Phys. Educ.* **50** 443–7
- [18] Arribas E, Escobar I, Suarez C P, Najera A and Beléndez A 2015 *Eur. J. Phys.* **36** 065002
- [19] Trantham K 2015 *Phys. Educ.* **50** 475–81
- [20] Tuset-Sanchis L, Castro-Palacio J C, Gómez-Tejedor J A, Manjón F J and Monsoriu J A 2015 *Phys. Educ.* **50** 580–6
- [21] Pendrill A M 2013 *Eur. J. Phys.* **34** 1379–89
- [22] Cabeza C, Rubido N and Martí A C 2014 *Phys. Educ.* **49** 187–94
- [23] Vieyra R, Vieyra C, Jeanjacquot P, Martí A and Monteiro M 2015 *Sci. Teach.* **82** 32–40
- [24] González M Á, da Silva J B, Cañedo J C, Huete F, Martínez Ó, Esteban D, Manso J, Rochadel W and González M Á 2015 *Proceedings of the Third International Conference on Technological Ecosystems for Enhancing Multiculturalism* (New York: ACM) pp 303–10
- [25] González M Á, González M Á, Martín E, Santos R, del Pozo A, Díez A, Prieto V, Martínez P, Aznar J and de los Mozos D 2015 *Proceedings of the XXXV Reunión Bienal de la RSEF y 25 Encuentro Ibérico de Enseñanza de la Física* (Spain: Gijón Universidad de Oviedo) pp 480–1
- [26] Huete F, Esteban D, da Silva J B, Skouri M, González M Á, Goudjami D and González M Á 2015 *Proceedings of the Jornadas de Redes de Investigación en Docencia Universitaria: Nuevas estrategias organizativas y metodológicas en la formación universitaria para responder a la necesidad de adaptación y cambio* (Alicante: Universidad de Alicante) pp 55–67
- [27] Pendrill A M 2016 *Phys. Educ.* **51** 015014
- [28] Monteiro M, Martí A C, Vogt P, Kasper L and Quarthal D 2015 *Phys. Teach.* **53** 247–9
- [29] Hirth M, Kuhn J and Müller A 2015 *Phys. Teach.* **53** 120–1
- [30] Kasper L, Vogt P and Strohmeyer C 2015 *Phys. Teach.* **53** 52–3
- [31] Hirth M, Gröber S, Kuhn J and Müller A 2016 *Phys. Teach.* **54** 163–7
- [32] Kinsler L E, Frey A R, Coppens A B and Sanders J V 1999 *Fundamentals of Acoustics* (New York: Wiley)
- [33] www.samsung.com/global/microsite/galaxyS4; this website was last visited 2015-12-02
- [34] This app can be downloaded from the following link: <https://play.google.com/store/apps/details?id=es.uva.audia>; this website was last visited 2015-10-29
- [35] Cañedo J C 2014 AudiA: Estudio de ondas sonoras y audiometrías en entorno Android *End of degree project* University of Valladolid
- [36] González M Á, González M Á, Martín M E, Llamas C, Martínez Ó, Vegas J, Herguedas M and Hernández C 2015 *J. Cases Inf. Technol.* **17** 31–50
- [37] Cooley J W and Tukey J W 1965 *Math. Comput.* **19** 297–301
- [38] <http://introc.cs.princeton.edu/java/97data/>; this website was last visited 2015-10-29.
- [39] <http://blog.faberaoustical.com/category/ios/iphone/page/3>, <http://electronics.stackexchange.com/questions/59157/over-what-frequency-range-can-the-microphone-of-smartphone-recvie-the-sound>; these websites were last visited 2015-12-13.
- [40] *Materials Data Book* (Cambridge University Engineering Department) www-mdp.eng.cam.ac.uk/web/library/enginfo/cueddatabooks/materials.pdf; this website was last visited 2016-4-7