



**Universidad de Valladolid**



**ESCUELA DE INGENIERÍAS  
INDUSTRIALES**

**UNIVERSIDAD DE VALLADOLID**

**ESCUELA DE INGENIERIAS INDUSTRIALES**

**Grado en Ingeniería industrial en electrónica y automática**

# **Exoesqueleto de mano para eliminar los temblores del Párkinson**

**Autor:**

**García Alcubilla, Rodrigo**

**Responsable de Intercambio en la Uva:**

**Martínez Rodrigo, Fernando**

**FH Technikum Vienna**

Valladolid, junio 2018.

TFG REALIZADO EN PROGRAMA DE INTERCAMBIO

---

TÍTULO: Hand exoskeleton to suppress Parkinson disease tremors

ALUMNO: Rodrigo García Alcobilla

FECHA: 22/06/2018

CENTRO: FH Technikum Vienna

TUTOR: Christian Kollmitzer

## Declaration of Authenticity

“As author and creator of this work to hand, I confirm with my signature knowledge of the relevant copyright regulations governed by higher education acts (for example see §§ 21, 46 and 57 UrhG (Austrian copyright law) as amended as well as § 11 of the Statute on Studies Act Provisions / Examination Regulations of the UAS Technikum Wien).

In particular I declare that I have made use of third-party content correctly, regardless what form it may have, and I am aware of any consequences I may face on the part of the degree program director if there should be evidence of missing autonomy and independence or evidence of any intent to fraudulently achieve a pass mark for this work (see § 11 para. 1 Statute on Studies Act Provisions / Examination Regulations of the UAS Technikum Wien).

I further declare that up to this date I have not published the work to hand nor have I presented it to another examination board in the same or similar form. I affirm that the version submitted matches the version in the upload tool.”

---

Place, Date

---

Signature

# Resumen

La enfermedad de Parkinson afecta a un gran número de personas mayores y sus síntomas impiden que los pacientes sean independientes en su vida diaria. Esta investigación se centra en el diseño de un exoesqueleto de mano para suprimir los temblores de Parkinson.

El diseño de un exoesqueleto para paliar los síntomas del Parkinson es una novedosa aplicación para estos dispositivos. Además del diseño mecánico del exoesqueleto, que incluye el diseño de las partes y la transmisión de la fuerza del actuador, se realizó la sensorización del dispositivo. El exoesqueleto tiene sensores de presión que detectan los temblores y movimientos de los dedos. Después, un microcontrolador procesa los datos recibidos y suprime los temblores de Parkinson para después controlar el actuador y mover el dedo a la posición deseada del paciente sin los molestos temblores.

El resultado final es un prototipo funcional que ayuda al paciente en los movimientos de agarre y bloquea los temblores producidos por el Parkinson. Sin embargo, el dispositivo aún necesita numerosas mejoras para convertirse en una solución real para el paciente.

# Abstract

Parkinson disease affects a large number of elderly people. Its symptoms prevent the patients to perform daily life activities and being independent. This research is focused on the design of a hand exoskeleton to suppress the Parkinson tremors and allow the patients to fend for themselves.

So far, other hand exoskeletons have been designed for rehabilitation purposes. The design of an exoskeleton to palliate Parkinson disease symptoms is a challenging and new application for these devices. In addition to the mechanical design of the exoskeleton, which includes the design of the parts and transmission of the force applied by the actuator, the sensorization of the device was done. The exoskeleton has pressure sensors that detect the finger tremors and movements. Then, a microcontroller processes the data received from the sensor and suppress the Parkinson tremors. The microcontroller controls the actuator to move the finger to the patients desired position without the annoying tremors

The final result is a functional prototype that assists the patient in the grasping movements and blocks the tremors produced by the disease. However, the device still needs several improvements to become a real solution to the patient.

**Palabras clave:** Exoesqueleto, Parkinson, Sensor de presión, Mecatrónica, Temblor

**Keywords:** Exoskeleton, Parkinson, Pressure sensor, Mechatronics, Tremor

# Acknowledgements

To my supervisor Christian Kollmitzer, who has done everything in his hand to help and advise me during these 4 months.

To all the teachers that I had in my life that gave their best efforts to transfer me their knowledge and values.

To my family, especially my parents and grandparents. Because of their love, support, values, and patient I have achieved all my goals and I have become a better person.

To Sara, who supports me every day and makes my life happier.

To anyone that is not mentioned above, but has helped me in any stage of my life.

# Table of contents

1	Introduction .....	4
2	Mechanical design .....	4
2.1	Actuators .....	5
2.2	Mechanism.....	6
2.2.1	Study of the finger movement .....	6
2.2.2	Final solution.....	7
2.3	Force calculation.....	9
2.3.1	Force in the finger .....	9
2.3.2	Motor force.....	10
2.3.3	Motor selection.....	11
2.4	Results .....	12
2.4.1	Finger movement with the exoskeleton .....	12
2.4.2	Force applied by the motor .....	13
2.4.3	Speed of the motor .....	14
3	Sensors.....	15
3.1	PD tremor detection .....	16
3.1.1	Accelerometers .....	17
3.1.2	Pressure sensors .....	18
3.2	Position sensor .....	22
4	Data analysis .....	23
4.1	Sampling .....	23
4.2	Offset adjustment.....	24
4.3	Low pass filter .....	25
4.3.1	Filter implementation and results .....	27
4.4	Actuator control.....	29
5	Conclusion and further developments .....	30

# 1 Introduction

Parkinson disease (PD) affects around 3.8 million people in the world [1]. PD is a neurological disease which motor-related symptoms are tremor, rigidity, slowness of movement and difficulty with walking and gait [2]. More than 70% of Parkinson patients suffer tremors in their upper extremities, which affects considerably to their daily life activities (DLA) preventing the operability with the hands because of the loss of strength and instability [3].

The most common treatment for PD is drug based. It results effective palliating rigidity and slowness, but ineffective with the tremors. The medication also entails prejudicial side-effects. In cases of severe tremor, the insertion of electrodes into the thalamus or subthalamic nuclei through brain surgery has been tried as an alternative. While this treatment is often very effective, it carries a significant risk for the patient [2].

A hand exoskeleton would be a non-invasive and low-cost solution to suppress the tremors and allow the patient to perform DLA. The research will focus on the suppression of the tremors in the hand, but tremors are also present in the whole upper extremity. Thus, to suppress the tremors completely and allow the DLA performance the exoskeleton should be extended to the whole arm.

Other hand exoskeletons have been designed in the past. There is a wide variety among the designed solutions and there are still several research questions without an answer because of the complexity of the problems. Most of these exoskeletons are designed for rehabilitation activities. This happens because the ones that are designed to assist in the DLA have more restrictions in terms of size and mobility [4]. There are exoskeletons that are designed to suppress PD tremors in the arm, but an exoskeleton specifically created to suppress the PD tremors in the hand has not been tried yet. As a result of this, in the research will arise numerous challenges and unanswered research questions.

The research will study first the mechanical design of the exoskeleton, then the sensorization, and finally the integration of both to control the actuator and suppress the PD tremors.

## 2 Mechanical design

The mechanical design is the most critical aspect in the development of the of the exoskeleton. The movement of the human hand fingers has a complex trajectory to which the mechanism has to adapt. The existing prototypes have tried different solutions to adapt the mechanism to the finger movements.

The mechanical design varies depending on the purpose of the exoskeleton. If it is used to rehabilitation processes, the size of the prototype it is not a problem, and the result could be bulkier. If the exoskeleton is used to perform daily life activities (DLA) it is necessary that the design is lighter. Thus, some challenges will emerge because of the miniaturization process, in which the design should be the lighter and smaller possible.

## 2.1 Actuators

The main difference between the previous attempts are the actuators. Some prototypes use conventional actuators as electrical motors, linear or rotational ones [5–9], or pneumatic pistons [10, 11] and others utilize different pneumatic soft actuators [12–15].

Soft actuators are the most suitable solution because they adapt the hand movement by themselves without the need of an external mechanism. Nevertheless, this kind of actuators are still in the development phase and not available on the market. Then, using soft actuators, despite being the best option, is not feasible.

The conventional actuators discussed before demand a mechanism to transmit the motor movement to the finger. Among these actuators, the greatest difference is if they are rotational or linear. Rotational ones need wires to transmit the movement, what makes the design more delicate, complex and bulky. In addition, two motors are needed for each finger, one for the flexion movement and other for the extension. Linear actuators do not require wires and are more similar to human muscles. Between the linear actuators, the electric motor has been chosen. Pneumatic actuators demand a source of compressed air, which is heavier and noisy, and its control is complex compared to the electrical motors.

Linear motors are used for specific tasks in the industry and its use is not as common as the rotational ones. In addition, in these uses the size of the motor is not a critical issue. Consequently, there are not many solutions in the market of linear motors with a small size. The best solution in the market is the 'Actuonix L12 series'. This motor has different stroke lengths, gear ratios and control options. The motor model will be chosen later.



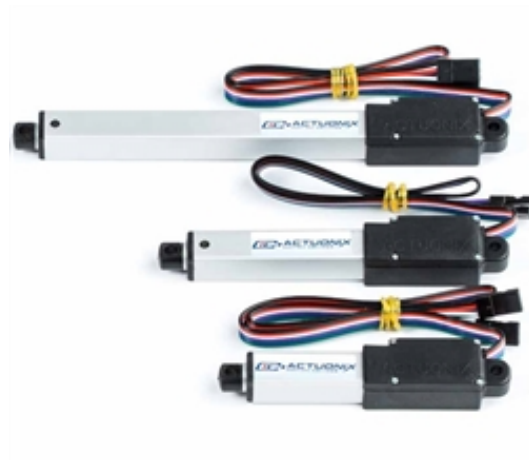

*Figure 1: Linear actuators 'Actuatorix L12 series'*

## **2.2 Mechanism**

Once the actuator has been chosen, a mechanism to transmit the force of the motor to the finger must be designed.

The movement of the finger follows a complex trajectory which is not always the same, it varies depending on the shape of the object to grasp or the movement that the patient wants to do.

Hence, a mechanism with only one degree of freedom (DOF) which only allows one trajectory has been discarded. In addition, the design of a mechanism adapts to one finger trajectory would need advanced methods of mechanical design and would be more complex.

The designed mechanism will have more DOF's than the finger, allowing multiple trajectories. The mechanism will adapt the natural finger movements because those movements need less force applied by the motor to move the finger. No harm will be caused to the finger by the mechanism because an antinatural trajectory will have more opposition to the movement than following the normal trajectory of the finger.

### **2.2.1 Study of the finger movement**

In order to make a proper design of the mechanism, a previous study of the hand and finger joints and trajectories must be done.

The finger has 3 joints, as shown in *Figure 2*. The metacarpophalangeal (MCP) joint has 2 DOF and the proximal interphalangeal (PIP) joint and distal interphalangeal (DIP) joints just have 1 DOF.

The wrist frame in *Figure 2* will be considered as the world reference. The pitch rotation will not be taken into consideration because another actuator would be needed, which would result in a heavier and bulkier design. Thus, just the yaw movement of the MCP will be treated in the design. In the PIP joint and DIP only the yaw rotation is present, and both will be taken into account during the mechanical design.

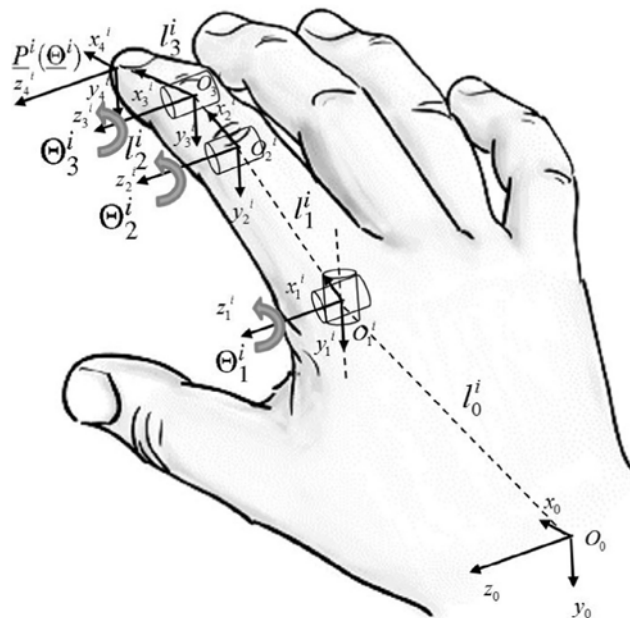

*Figure 2: Finger joints [6, p. 195]*

A critical parameter of this project is the wanted amplitude of the finger movement. If the movement is larger, the mechanism will be bulkier and more complex. The maximum angle of each joint has been chosen to allow a natural and complete grasp and to not compromise the design in terms of size or viability. The MCP maximum angle chosen is  $45^\circ$ , in the PIP is  $90^\circ$  and in the DIP is  $60^\circ$ .

## 2.2.2 Final solution

After the analysis of the finger movement, the mechanical design of the exoskeleton can be done. The mechanism will transmit the force of the linear motor to the finger, which mechanism will adapt to the finger movement.

Three parts have been designed, one for each phalange, to adapt the movement of the mechanism to the joints of the finger. Those parts are connected between them by a rotational joint, which centre coincides with the finger joints centre.

The linear force of the motor is transmitted by 5 linkages. Three of them are connected to the parts attached to the phalanges. Another linkage connects the one attached to the first phalange with the other two and the last one connects the motor with the first phalange linkage. The final mechanism is shown in *Figure 3*. The length of the linkages had been specifically chosen to allow the mechanism to follow the movement of the finger. Not every combination of linkages is valid, if the lengths are badly chosen the movement could be blocked. The lengths were chosen empirically with the help of the CAD simulation software. Furthermore, some linkages and parts have modifications in their shape to prevent blockings between the linkages and parts.

The linkages and parts are connected by screws and nuts of 2.5mm. The rotational joints between the phalanges do not need screws because the male and female connexions are included in the part design.

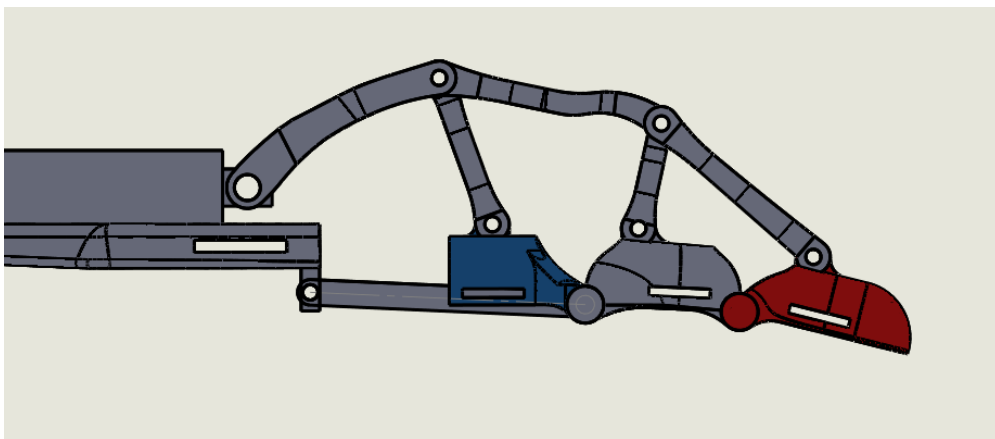

*Figure 3: The designed mechanism*

The parts and linkages are designed with the SolidWorks 2018 © computer-aided designs (CAD) software and printed with additive manufacturing techniques. The parts are printed with a 3D printer based in the SLS (selective laser sintering) technology. This technology was chosen because it allows printing complex surfaces and cantilevers, as the parts have.

## 2.3 Force calculation

With the mechanical design developed, the motor force can be calculated. The force is determined by the weight that the exoskeleton has to bear. That weight must be enough to perform the majority of the DLA. The weight that was considered enough to perform DLA was 1 Kg. The last step is to analyse the force transmission in the mechanical structure and the needed motor force.

### 2.3.1 Force in the finger

The maximum weight that the exoskeleton will grasp is 1 Kg. As the hand has 5 fingers, the exoskeleton will have 5 motors that will apply force. The force will be divided equally between all the fingers. Therefore, each motor will handle 200 grams.

To grasp an object the finger applies to force to it. That force is divided into a normal force given by the action-reaction principle (third law of Newton) and a friction force given by the *Equation (1)*, being  $\mu$  the friction coefficient.

$$Fr = \mu \cdot N$$

*Equation (1)*

In this study, the worst-case scenario will be analysed. Hence, it will be analysed the case when there is only present the friction force, where the motor will have to apply the maximum force.

One of the critical aspects to calculate the friction force is the determination of the friction coefficient. In [16, p. 19] can be seen the empiric data of many experiments. The friction coefficient decreases exponentially when the pressure increases and then it stabilises. As the worst-case scenario is being studied, the selected friction coefficient was  $\mu = 0.2$ , the minimum coefficient of the data. The maximum pressure applied by the finger can be calculated with the *Equation (2)*, the average surface of the finger I between  $2 \text{ cm}^2$  and  $3.5 \text{ cm}^2$  [16, p. 16]:

$$P = \frac{N}{S_{finger}} = \frac{m \cdot g}{\mu} \cdot \frac{1}{S} = \frac{0.2 \cdot 9.8}{0.2} \cdot \frac{1}{2 \cdot 10^{-4}} = 4.9 \text{ kPa}$$

*Equation (2)*

The contact pressure is within the range of the data [16, p. 16]. Hence, the assumption of the value of the friction coefficient was valid.

Once the friction coefficient is known, the force applied in the finger by the motor can be calculated. There must be a balance between the friction force and the weight of the object, as shown in *Equation (1)*:

$$Fr = \mu \cdot N = m \cdot g \rightarrow$$

$$N = \frac{m \cdot g}{\mu} = \frac{0.2 \cdot 9.8}{0.2} = 9.8 \text{ N}$$

### 2.3.2 Motor force

To calculate the final motor force needed, the power transmission between the motor and the mechanical design must be analysed. It is assumed that the plastic parts are thinner and lighter enough to not take them into account and that the force applied in the first linkage is transmitted completely to the finger.

The power transmission between the motor and the first linkage depends on the angle between them. The worst-case-scenario, where the angle between the motor and the linkage is maximum, will be analysed. This angle will be determined empirically in the CAD simulation. As shown in *Figure 4* the maximum angle is  $\beta = 65.86^\circ$ .

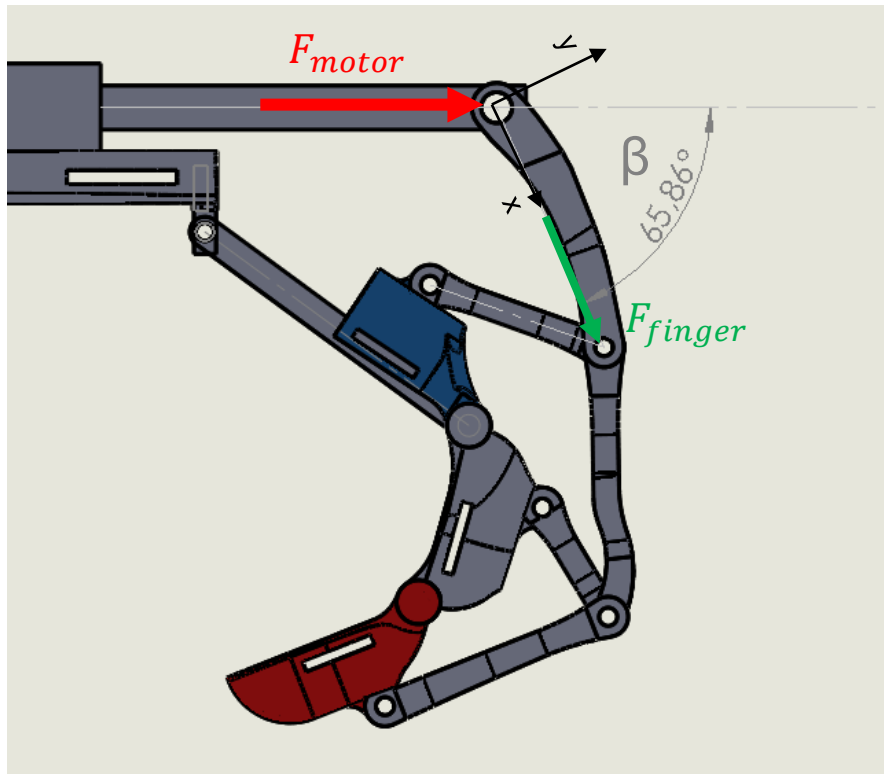

Figure 4: Force transmission in the mechanism

The relation between both forces, and the resultant force, is shown in Equation (3):

$$F_{finger} = \cos(\beta) \cdot F_{motor} \rightarrow$$

$$F_{motor} = \frac{F_{finger}}{\cos(\beta)} = \frac{9.8}{\cos(65.86)} = 23.96 \text{ N}$$

Equation (3)

### 2.3.3 Motor selection

In the previous discussion about the actuators, the Actuonix linear motor was chosen, but not the specific model. The decision will be based on two parameters, the force and the stroke. The stroke needed by the mechanism to reach the final position is 48.5 mm. Then, the model of 50mm of stroke is adequate. The maximum force that the motor has to apply is approximately 24 N. The chosen model has a maximum force of 42N lifted and 22 N static. It

has also a speed of 13 mm/s. The nominal voltage of the motor will be 6 V, the same as the future microcontroller.

## 2.4 Results

### 2.4.1 Finger movement with the exoskeleton

With the mechanical model printed, including a designed part where the motor is attached and placed above the hand, the designed model has to be verified. The mechanism fits on the finger and in the hand, allowing the natural movement. Therefore, no modifications in the mechanical design were required. The parts are attached to the hand with flexible straps, with sewed Velcro, that fastens the parts to the finger.

First, the differences between the finger trajectory with the exoskeleton and without were analysed. The trajectory was analysed with a motion capture software (open source) called Kinovea. This software follows the black markers that were painted on the finger. The analysed movement was the opening gesture of the hand in both cases.

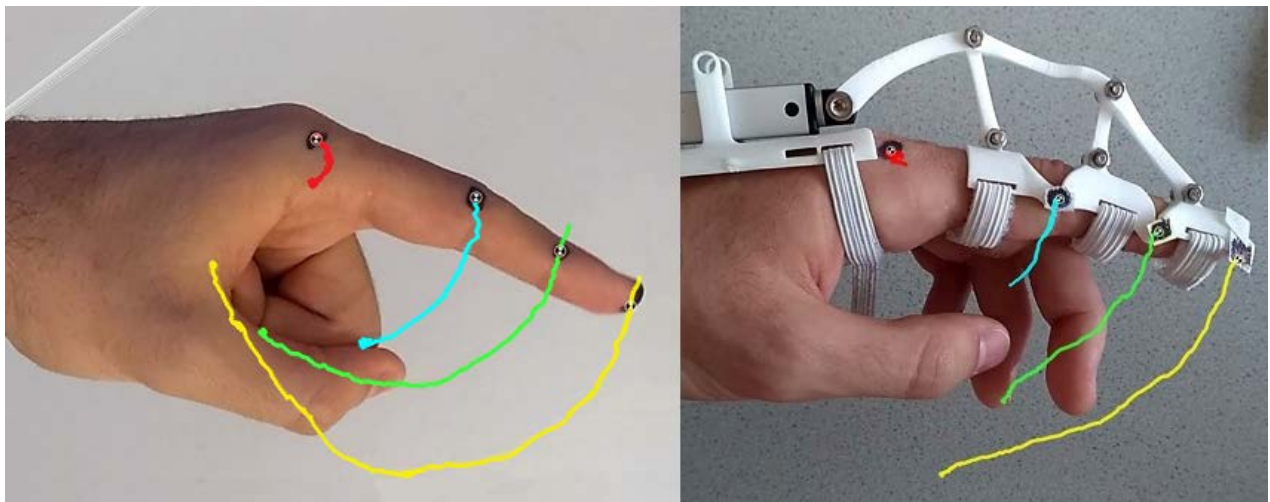

*Figure 5: Trajectory of the finger, without exoskeleton in the left and with exoskeleton in the right*

The main difference between the trajectories shown in *Figure 5* is that with the exoskeleton the movement is patently shorter. This was expected because in the designing process the maximum angles of each joint were proposed. Bigger angles would result in a bulkier

mechanism because it needs more length in the linkages and more stroke length in the actuator.

In addition, the trajectory with the exoskeleton could be slightly less curved. However, the difference is almost undetectable and it is not noticed while wearing the exoskeleton.

So, the main difference of the finger movement with the exoskeleton attached is that is shorter than the normal one.

## 2.4.2 Force applied by the motor

In 2.3 the theoretical force applied by the motor was calculated in order to select the appropriate motor. Once the motor is ordered and the mechanism printed, the veracity of the calculations must be proved.

In *Figure 6* the relation of the consumed current by the motor and the force is shown. This data was given by the manufacturer of the motor (Actuonix).

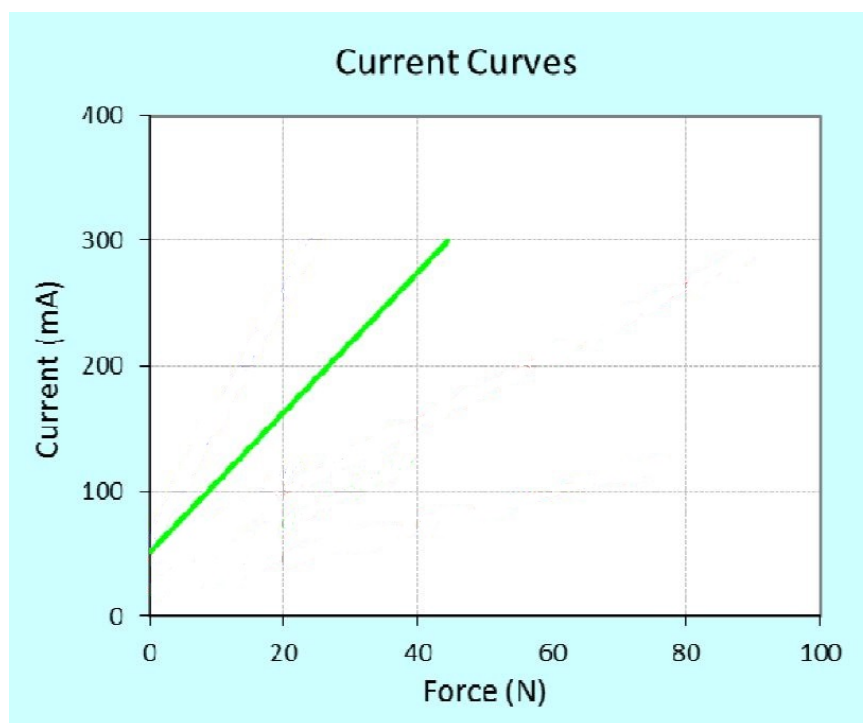

*Figure 6: Relation of the current with the force applied by the Actuonix motor [17]*



It was also measured the force needed to do the opening and closing gesture without any opposition. The closing gesture consumed 85 mA, which is equivalent to approximately 5 N. The opening gesture consumption was 74 mA, which corresponds to 4 N.

The last test that was conducted measured the force applied with the total opposition of the finger to the movement of the motor. This force varies for each person, so this data should be reviewed for each patient. In both cases, despite the finger opposition, the motor could move. The maximum force applied in the closing gesture was approximately 15 N (140 mA). In the opening gesture, the maximum force was 23 N (180 mA).

The calculated force in 2.3 was approximately 24 N. It was calculated for the worst case scenario, where the motor was applying a pushing force to grab an object of 1Kg (200 grams each finger). A test with 200 grams was not conducted because the motor could beat the resistance of the finger of a healthy person, which is noticeably higher than 200 grams. Then, the exoskeleton will be able to grasp objects of 1 Kg or more.

### **2.4.3 Speed of the motor**

Finally, the real speed of the linear motor will be tested. It is an important parameter for the project because the capability of closing or opening the hand in a reasonable time is critical for the DLA. If the closing or opening is too slow the usefulness of the exoskeleton would be drastically reduced.

The speed test was conducted without any opposition to the motor movement. When the motor has to counter another force the speed decreases, as shown in *Figure 7*.

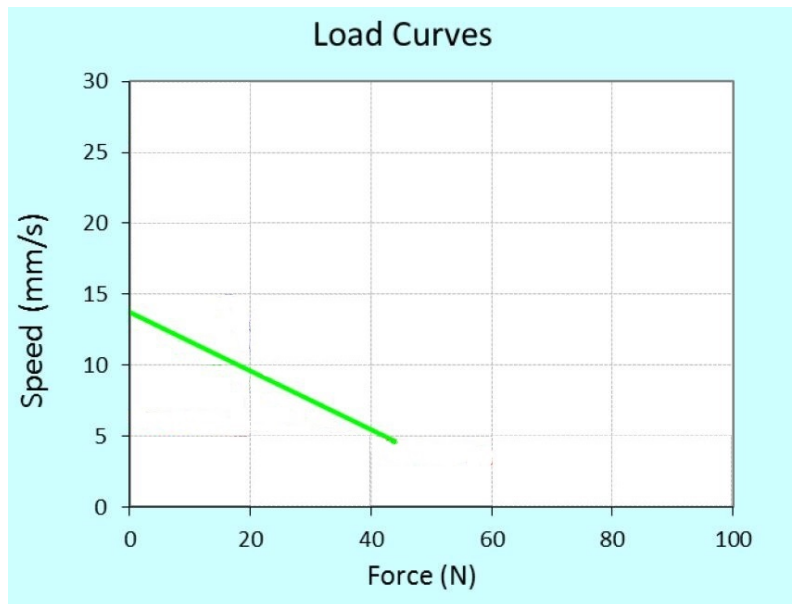

Figure 7: Speed relation with the force applied by the motor [17]

The speed without any opposition is 13 mm/s according to the information provided by the manufacturer. The speed of the real closing and opening gestures is 12 mm/s. Even though there is no opposition of the finger, in 2.4.2 it has been measured a small force of 4 N for the opening gesture and 5 N for the closing gesture because of the movement of the mechanism. Therefore, it is reasonable that the motor has a slightly lower speed. There are no differences between the speed in the closing gesture and opening gesture.

As said in 2.3.3, the length of the stroke needed to do the whole gesture is 48 mm. If the speed of the motor is 12 mm/s, the time needed to perform the gesture is 4 seconds. The accelerations and decelerations are negligible.

### 3 Sensors

With the mechanical design finished, the next step in the construction of the exoskeleton is the sensorization.

First, a deep study of the parameters that are interesting for the applications of the exoskeleton needs to be done. The study will be focused on the functionality of the exoskeleton and on the parameters related to the Parkinson disease (PD). Then, the appropriate sensors to measure those parameters of interests can be selected. The sensors will have to measure the desired parameters and fit into the exoskeleton. Which means that the sensors will have to be small

enough to be part of the design and adapt to the finger movement. The capability of the sensors to fit into the project requirements is critical for the future functionality of the exoskeleton. It is one of the major challenges due to the small size and the strong restrictions of the mechanical design in terms of movement and functionality.

### **3.1 PD tremor detection**

The main purpose of the exoskeleton is to assist the PD patients in the performance of the DLA. The tremors produced by the PD are the major problem that the patients that suffer this disease have to face in their daily life. Thus, the information of the frequency and intensity of the tremors will be the most important information in the project. With these data, an FFT (Fast Fourier Transform) can be done. This allows the analysis in the frequency spectrum of the tremors, what will show the harmonics present in the PD patient tremor.

Previous researches, as [2], have concluded that the PD patients present three harmonics in their finger and elbow movements that have enough power to be taken into account. The data was taken with the patient in a resting position, so all the harmonics correspond to the PD tremors. Therefore, filtering the harmonics present in the acquired data will result in the filtering of the undesired PD tremors. To suppress the tremors, the microcontroller will filter the frequencies where the tremors are present and just take into account the lower frequencies. The actuator will have as reference just the desired movement, with the harmonics filtered. In practice, this will block the PD tremors, allowing the patient to perform DLA without the annoying tremors.

The study of the Parkinson tremors in the hands have shown that typically the first harmonic is within the range of 3.5 Hz and 5.8 Hz, the second within 6.9 Hz to 11.5 Hz and the third within 10.4 Hz to 17.3 Hz. The data can be seen in *Figure 8*.

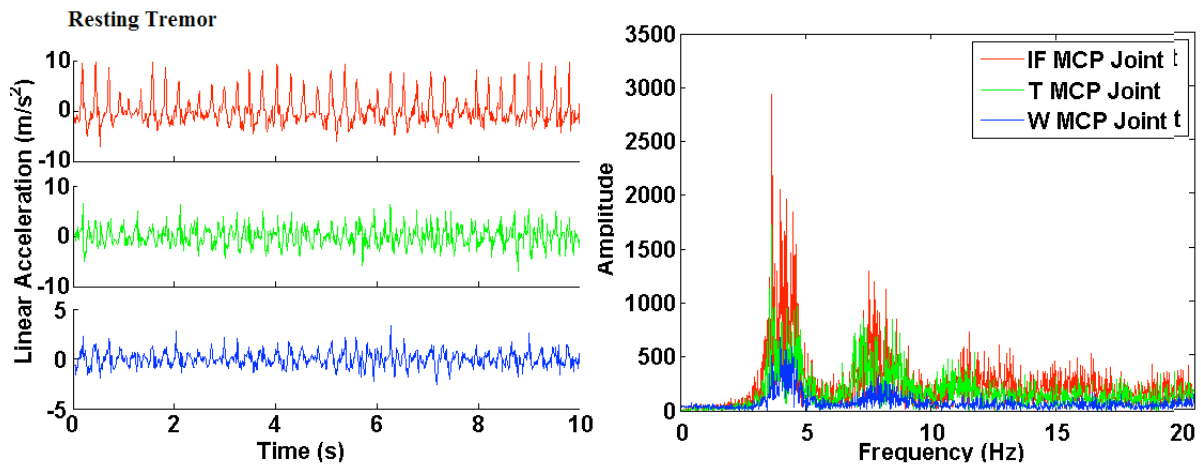

Figure 8: Obtained data and FFT of a PD patient with the hand position parallel to the table plane (resting tremor) [2].

However, an important deviation in the statistic sample has been detected. The possible reasons could be the different stages of the patients in the disease or the unconscious suppression of the tremors during the test. A personal analysis should be done for each patient to adjust the filtering parameters.

To conclude, the analysis of the frequency domain of the tremors could lead to the correct diagnosis of the patient disease. Sometimes the PD is confused with other neurological diseases that also produce tremors in the patient extremities [18]. The most common disease that is misdiagnosed and confused with PD is the essential tremor. The main harmonic of the essential tremor shows up in the range of 4 to 12 Hz and the PD between 3 to 6 Hz [2, 18]. With the proper analysis, information for the correct diagnosis can be obtained, which will produce important benefits for the patient.

### 3.1.1 Accelerometers

Accelerometers are the most used sensors to detect tremors in PD patients. These sensors measure accelerations, in the three axes, and gravity. With that information the amplitude and frequency of the tremors can be easily determined, which makes the accelerometers an adequate option to measure the tremors.

Many projects have used the accelerometers to measure the tremors of the hand or the arm [2, 19–21]. In these applications, the patient does not have the movement blocked by any device and the hand can move with total freedom. This makes the accelerometer perfect for

measuring the tremors. However, the exoskeleton purpose is to suppress the tremors, then, no movement should be produced, and the accelerometer will not detect it.

In addition, accelerometers have a significant size, which would make difficult attaching them to the finger.

Therefore, accelerometers are the best option for the majority of the tremor detection projects, but they are not valid for this exoskeleton because the tremor has to be produced to detect it.

### **3.1.2 Pressure sensors**

The main advantage of the pressure sensors, compared to the accelerometers, is that no movement is needed to detect the tremor.

A pressure sensor placed inside one of the phalanges parts of the exoskeleton could measure the force applied by the finger to the exoskeleton. If the exoskeleton is blocking the movement, the applied force will show the desired movement of the finger and the tremors.

There are two different types of pressure sensors that could be used to detect the finger force. The first family of sensors gives as an output a variable voltage in response to an applied pressure, in this family piezoelectric sensors are included. The piezoelectric sensors are widely present in the market. However, most of them are used in industrial areas where size is not a restriction. The few small sized alternatives in the market have interesting properties for the project, but the price is much higher than the other alternatives. Thus, piezoelectric sensors are valid alternatives in terms of performance, but the price is excessively high. However, if a cheaper sensor comes on the market it will have to be considered as a possible option.

The other family of sensors is based on a resistance change with an applied pressure. Many commercial alternatives are available, manufactured in varied materials as polymers, metals or semiconductors, and with a competitive price. In this family, the most used sensors are the strain gauges. They are made of different types of metal, and they need to be included in load cells, which are bulky. Therefore, strain gauges are discarded because of its size. Other sensors of this family, manufactured in different materials than strain gauges, have more interesting characteristics as their thinness. Thus, this kind of sensors are the chosen for this project.

Among the resistance change based sensors, two alternatives were tested. One was a pressure sensitive foil called Velostat®, this material changes its resistance with the pressure

or bending. The main advantage of this material is that it could be cut and adapted to the whole phalange part, achieving a larger sensitive surface than other sensors. Nevertheless, the repeatability of the material is insufficient, and the dynamic response is not adequate because it presents significant overlaps.

The other alternative is a circular sensor, that has different sensitive surface diameter options. That sensor is made of polymer thick film (PTF) and offers a robust dynamic response and repeatability. The chosen size was of 0.5 cm diameter. The resistance decreases with the force applied and detects forces from 0.2 N to 20N [22].



*Figure 9: Pressure sensor with a circular sensitive area*

Two pressure sensors will be installed in each finger to detect the tremors. Both will be in the fingertip, where the force applied is higher. One will be above the finger, close to the nail and stuck to the phalange part of the exoskeleton mechanism. The other one will be placed in bellow the finger, stuck to the strap that is used to fasten the phalange part.

### **3.1.2.1 Pressure sensor integration**

The pressure sensor chosen changes the resistance with the applied force. This resistance change has to be converted to a voltage change that can be measured by the microcontroller. A circuit with a voltage divider is the easiest way to convert the resistance change to a voltage change. The scheme is shown in *Figure 10*, where  $R_s$  is the sensor and  $R_m$  the measuring resistor.

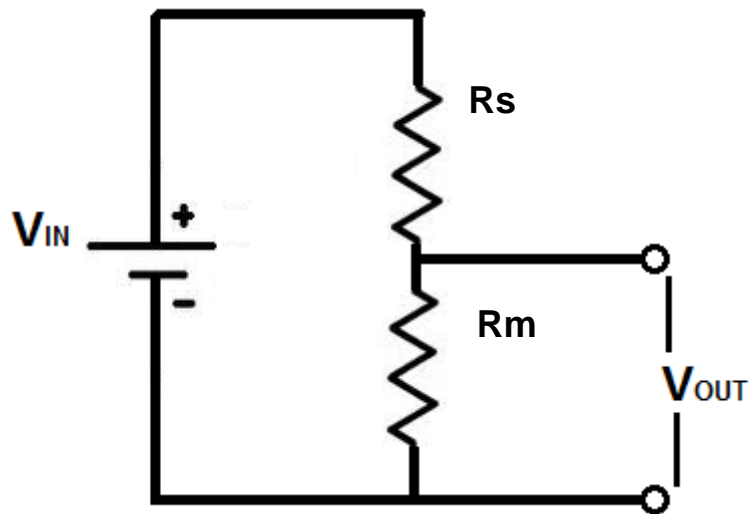

Figure 10: Voltage divider scheme

In order to maximize the precision of the data acquisition in the ADC the measuring resistor will be chosen so that, when the maximum force is applied to the sensor the output voltage will be the maximum voltage allowed by the ADC.

The Arduino ADC range goes from 0 V to 5V. The pressure sensor has almost an infinite resistance when force is not applied. In that case, all the voltage drop occurs in the sensor. This characteristic is very positive because when the force is 0 newtons, the voltage output is 0 volts. The absence of a voltage offset avoids the use of an analogic operational amplifier, configured as a subtractor circuit, to eliminate the offset in order to use the whole range of the ADC. Because of that, the circuit is simpler, which is helpful to this project because the need of miniaturization of the exoskeleton components.

When force is applied to the sensor, the resistance decreases as shown in *Figure 11*. The minimum resistance (maximum force) in each sensor was measured. The resistor placed above the finger had a minimum resistance of  $R_{s1} = 15 \text{ k}\Omega$ , which is equivalent to approximately 160 g (1.57 N). The resistor placed in the strap had a minimum resistance of  $R_{s2} = 6 \text{ k}\Omega$ , equivalent to 300 g (3 N).

The force that the sensor measures is not the total force applied by the finger, it is just the force applied to the sensitive surface of the sensor. The total force applied is proportional to the measured force. The proportion is different in each sensor, and the difference between the maximum forces measured in each sensor does not mean that the force in the opening gesture (sensor placed above the finger) is bigger than the force applied in the closing gesture (sensor placed in the strap).

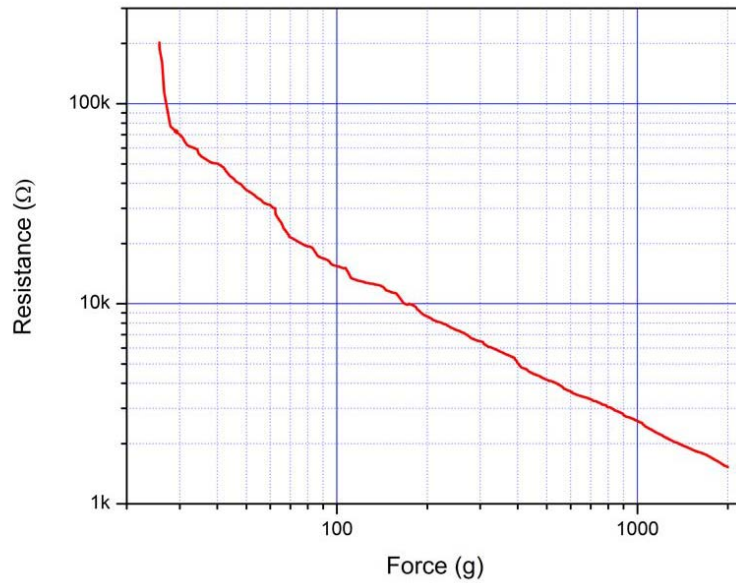

Figure 11: Resistance-force graphic of the pressure sensor [22]

After measuring the minimum resistances in each case, the measuring resistor has to be calculated to get 5V in the output when the resistance is minimum. Analysing the circuit of *Figure 10*, the output voltage relation with the sensor, the measuring resistance and the source voltage is shown in *Equation (4)*. The voltage source will be in both cases 6V, the voltage needed to supply the linear motor and the Arduino.

$$V_o = V_s \cdot \frac{R_m}{R_s + R_m}$$

Equation (4)

The measuring resistance for each case can be calculated with *Equation (5)*. The desired output voltage will be 5V. For the sensor placed in the phalange part the measuring resistance would be  $R_{m1} = 75 \text{ K}\Omega$  and for the other sensor the result is  $R_{m2} = 30 \text{ K}\Omega$ .

$$R_m = R_s \cdot \frac{V_o}{V_s - V_o}$$

Equation (5)



## 3.2 Position sensor

The information of the position of the joints can be useful to control the patient behaviour with the exoskeleton. It is not as critical as the pressure information, but it can be helpful to detect if the patient is adopting antinatural positions, that could be harmful if they persist, because of the exoskeleton. Also, it could help in the control, to get an idea of the shape of the grasped objects by the patient.

The motor gives information of the length of the stroke, but not of the position of the joints of the finger because the mechanism has multiple DOF's and allows multiple configurations. Therefore, additional sensors are required.

As said before, the main problem of the sensorization of the exoskeleton are the restrictions of size and integration in the mechanical structure.

Three options were considered. First, a hall effect-based sensor. This sensor would be integrated into one phalange part, and in the other part a magnetic field emitter. When the angle between both phalanges changes the flux that goes through the sensor would change, giving as a result a change of the voltage output of the sensor. The precision of this sensor is high, but the integration is complex. The sensor and the magnetic field emitter should be close to prevent external noises, so it should be placed in the rotational centre of the joint where the integration is difficult. In addition, the exoskeleton would need at least two sensors and the number of components and wires would be higher than other alternatives.

The second alternative was a gyroscope. The gyroscope measures the angular speed, so the angular position can be easily calculated just multiplying by the time. The problem of this sensor is that is incremental, and it needs a calibration each time that the exoskeleton is used to determine the first position of the sensor, and then the successive angle increments have to be added to that position. Also, the problem of an incremental sensor is that the errors committed during the measurements are accumulated and the result can degrade with the time. The integration in the exoskeleton parts, as in the hall effect sensor, is not easy because of the restrictions. Therefore, this sensor has more disadvantages than advantages comparing to the hall-effect sensor and it has been discarded for this project.

The third alternative was a sensor that changes its resistance when it is bent. There are different alternatives in the market like metal wires, flex sensors and other materials. Among all of them, a material called Velostat was chosen. This material changes its resistance when it is pressed or bent. It would be placed in the superior part of the exoskeleton, so the material will not have any pressure and it will act just as a bend sensor. The other alternatives were discarded because of the difficulty of its integration in the exoskeleton, the flex sensors were

too long and the metal bars fragile. The main advantage of the Velostat is that is a foil that can be cut with the shape of the exoskeleton, then the integration is easy and effective.

A test with the Velostat was conducted. The problem was that in the superior part of the finger when the finger bends the length changes. The material was not flexible enough and it did not allow the finger to bend. As a result of this, the Velostat material was discarded too.

A material with properties similar to Velostat, but flexible, was ordered. The flexibility of this material could solve the problem that did the Velostat an unsuccessful alternative. However, a test was not conducted. The next step of this research will involve the test of this material as a position sensor.

## **4 Data analysis**

The main goal of this project is the detection and suppression of the PD tremors. As discussed before, the tremors are detected by pressure sensors placed in the finger structure. The data obtained with the pressure sensors must be treated to distinguish the PD tremors and the desired movement of the finger.

The analysis of the data will be made by the Arduino microcontroller, so it will be completely digital. There are some tasks that could have been implemented with analogic circuits, as the filters or the offset suppression. However, the digital analysis is more flexible and easily modifiable which is an important characteristic due to the differences between the PD patients. Some patients may present the tremors in different frequencies, so the filter may need some changes between patients.

### **4.1 Sampling**

The first step in a digital data analysis is the definition of the sampling frequency. This step is critical to avoid the aliasing of the signal, which will conclude in a deficient reconstruction of the real signal and a loss of information.

First, the maximum sampling frequency of the Arduino microcontroller must be known. If the sampling frequency is not enough other solution must be designed. The "Arduino family" average time of conversion in the ADC (analog to digital converter) is 100 us. Hence, the maximum sampling frequency is 10 KHz.

The sampling theorem of Nyquist-Shannon says that the sampling frequency must be at least two times the highest frequency present in the signal to avoid aliasing *Equation (6)*. In practice, the sampling frequency will be between 20 and 40 times the maximum frequency to prevent loss of information.

$$f_{sampling} \geq 2 * f_{signal}$$

*Equation (6): Nyquist-Shannon theorem*

Thus, if the maximum frequency of the tremors signal is 17.3 Hz the sampling frequency will be between 346 Hz and 692 Hz. The sampling frequency is smaller than the maximum sampling frequency supported by Arduino so, the microcontroller ADC is valid for the project.

However, as the Arduino will not have many tasks to perform and will have enough calculation capacity. The final sampling frequency will be 1 KHz. With a higher sampling frequency, the accuracy is higher.

## 4.2 Offset adjustment

The exoskeleton is secured to the finger with straps. When those straps are fastened they exert a pressure to the finger. That pressure is constant and is detected by the pressure sensors. The pressure sensor attached to the strap is more influenced by this pressure than the one placed above the finger. However, both are influenced.

This offset must be corrected to differentiate the pressure applied by the finger and the pressure that is a consequence of the strap. This offset varies each time that the exoskeleton is secured because each time the strap will be fastened with a different intensity. Therefore, the offset must be analysed by the microcontroller autonomously.

Two options were studied as a solution. The first was a high pass filter that filtered the continuous part of the signal, which is the offset. The filter would need strict conditions, with a high attenuation slope, because the continuous part of the signal must be suppressed but the low frequencies components of the signal must be conserved. In addition, another problem of this alternative is that a low pass filter is also needed to suppress the PD tremors in the signal. As a result of this, the filter would have been a bandpass filter with high restrictions, which would result in a complex and slow filter that would compromise the real-time response of the actuator.

The second option, the one that was implemented, consists in a calibration when the exoskeleton is secured. Before the exoskeleton starts to assist the patient, the microcontroller



This configuration helps in the implementation of the filter in the microcontroller because the computation is reduced to *Equation (7)* and *Equation (8)*, being  $g_1$  the gain before the filter.

$$V(n) = X(n) g_1 - V(n - 1) a_1 - V(n - 2) a_2$$

*Equation (7)*

$$Y(n) = V(n) b_1 + V(n - 1) b_2 + V(n - 2) b_3$$

*Equation (8)*

The magnitude response of the designed filter is shown in *Figure 13*. The filter has 0 gain until 3 Hz (pass frequency) and in 5 Hz (stop frequency) the attenuation is 20 dB, which means that the output value would be 10 times smaller than the input value.

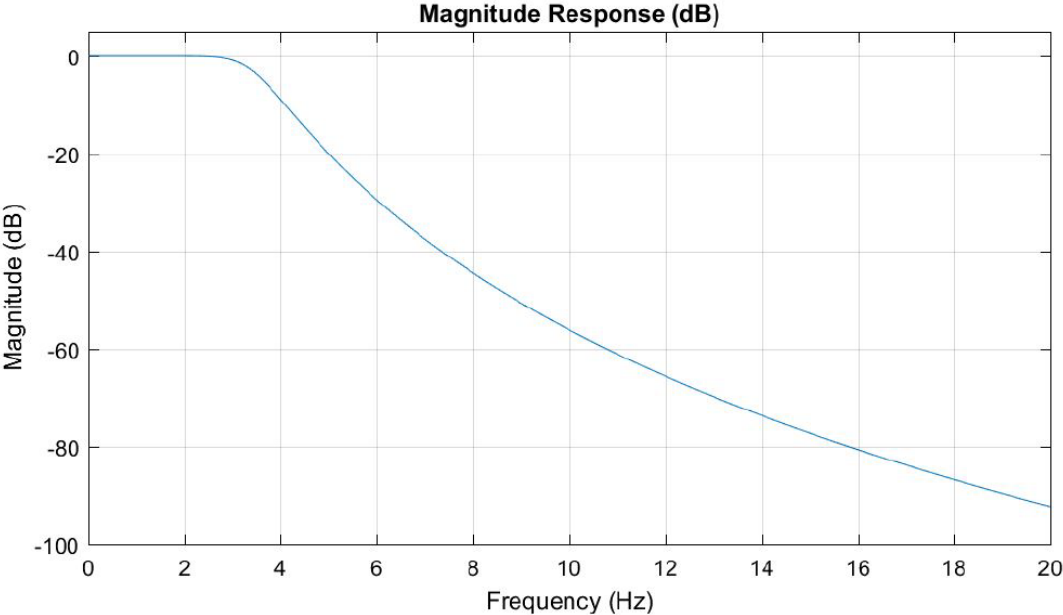

*Figure 13: Magnitude response of the low pass filter*

### 4.3.1 Filter implementation and results

The filter designed in MATLAB has to be implemented in the microcontroller to filter the data in real time, simultaneously with the sampling.

The implementation in c code is simple. The filter section structure, based on *Equation (7)* and *Equation (8)*, will be implemented in an independent function. That function will be executed three times, one for each section, with the corresponding parameters.

The Arduino microcontroller float data type just allows 8 significant numbers. The parameters of the filter have at least 12 significant numbers, so there will be a loss of precision in the filter.

A test of 12 seconds (12000 samples) was done to see the differences between the ideal filter and the implemented filter in Arduino. The original data, with the continuous signal and the FFT spectrum plots, sampled by Arduino and analyzed in MATLAB is shown in *Figure 14*. The test was conducted by a person that does not suffer PD. However, with this procedure the main harmonics of the PD tremors of each patient could be determined and the filter adjusted to the particular needs of each patient.

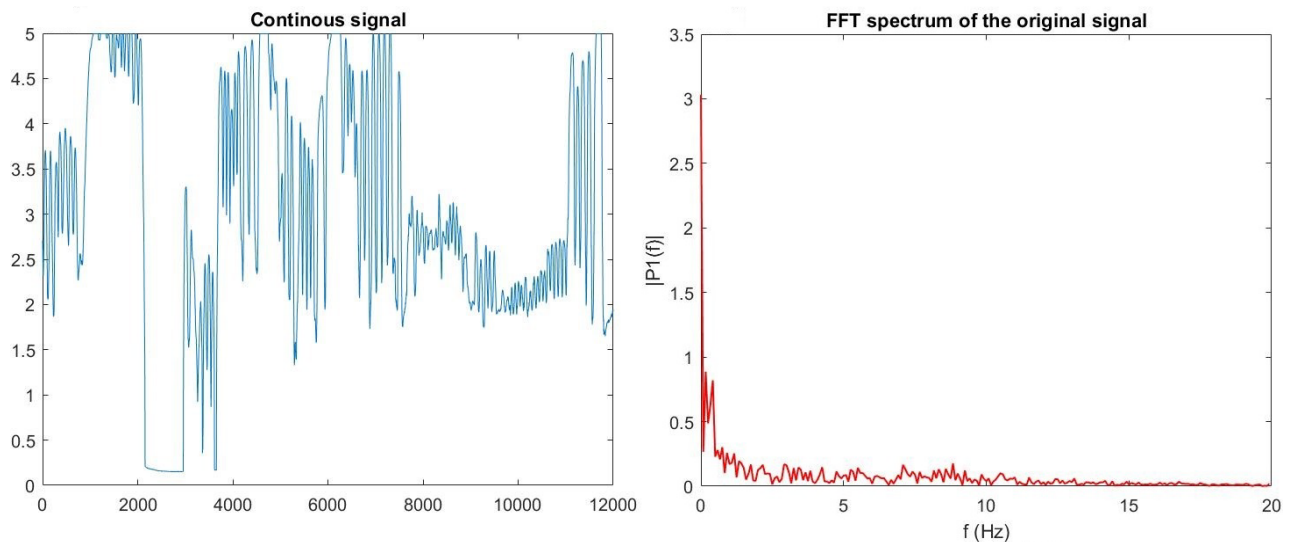

*Figure 14: Test original data*

The results of the filter implemented in Arduino are shown in *Figure 15*. The filter has the expected behaviour, the components of the signal that goes from 3 Hz and above start to attenuate and in approximately 4 Hz are almost extinguished. It is remarkable that the filtered signal presents a delay of approximately 300 samples (0.3 seconds). This delay is acceptable because the exoskeleton is designed to perform open and close gestures with a medium

speed, which is also restricted by the speed of the linear motor. It is also worthy of attention that the filtered signal presents some overlaps when the values of changes sharply. The original signal has values between 0 and 5 V, the range of the ADC, and the filtered signal with those overlaps surpass that values.

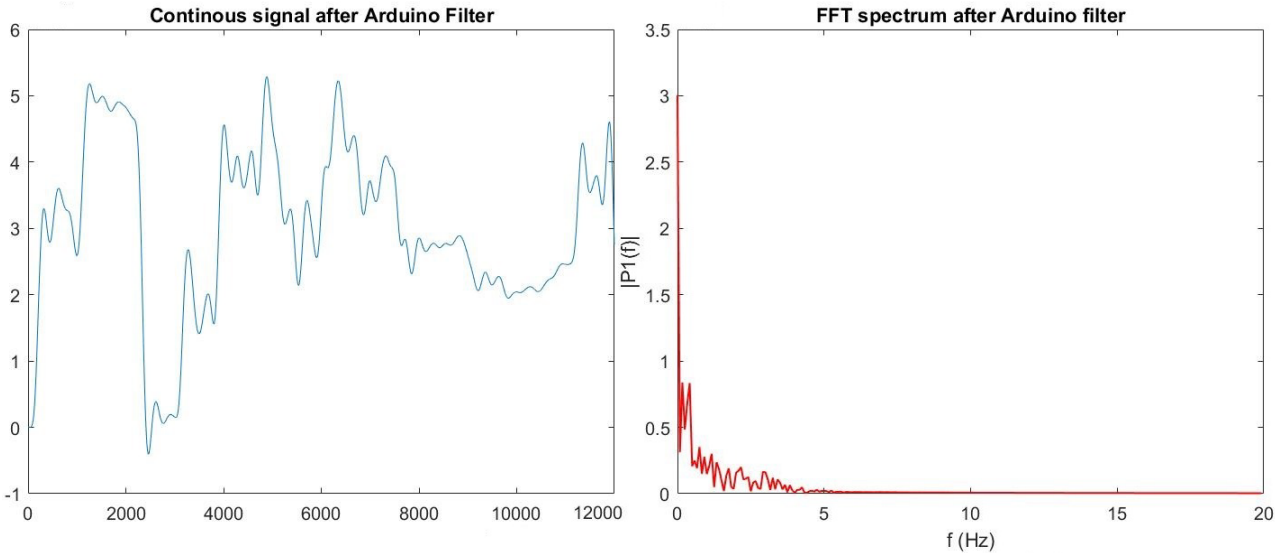

Figure 15: Results of the filter implemented in Arduino

The results of the filter designed in MATLAB is shown in *Figure 16*. The result is almost the same as the one implemented in real time in Arduino. This means that the loss of accuracy because of the data type of the parameters is not appreciable. It was also verified in Arduino that all the necessary operations made by the microcontroller can be done in one sampling cycle of 1 ms. The totality of the operations, which include the sampling and the mathematical calculations of the filter for both sensors, were concluded in 200 us. The possibility of performing every operation without losing any sample cycle, which in practice means that the sampling frequency is reduced, means that the filter implemented in Arduino in real time can behave like the filter design in MATLAB, as proved in the test.

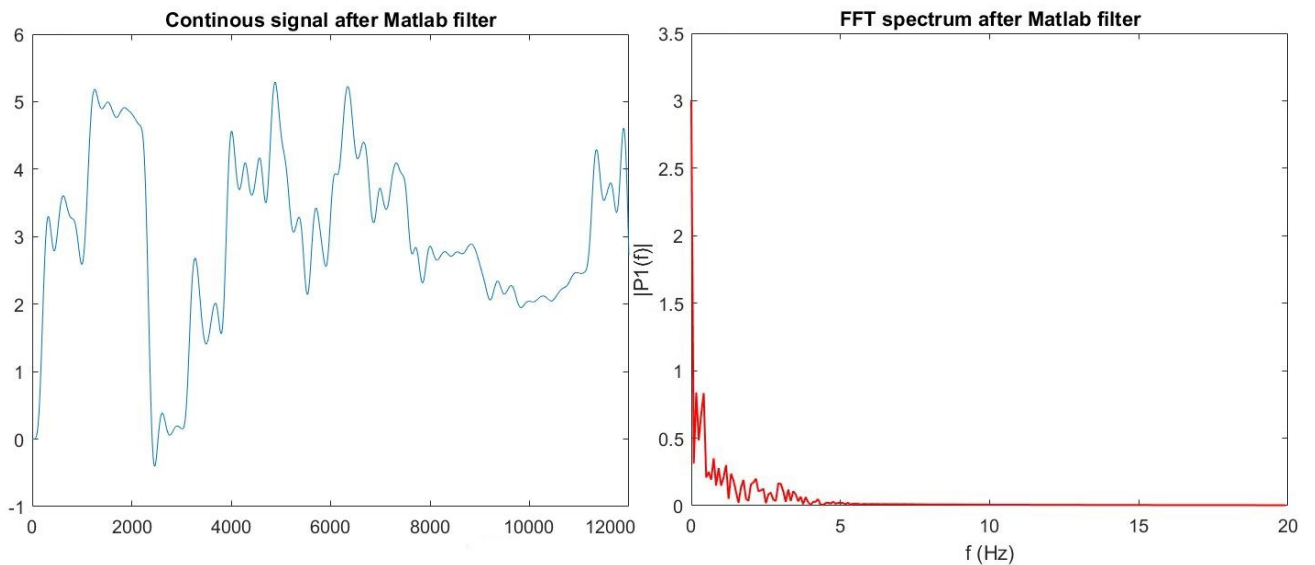

Figure 16: Results of the filter designed in MATLAB

## 4.4 Actuator control

With the PD tremors removed by the filter, the information of the desired movement of the finger can be analysed and the orders to the actuator can be sent.

The linear motor has an internal controller that receives a position reference. The reference is a voltage value, 0 V means that the motor is completely retracted, and 5 V fully extended. In the intermediate voltages, the length of the stroke (from 0 to 50 mm) is proportional to the voltage (from 0 to 5 V).

The information that the signal gives is the pressure applied by the finger when it wants to move. That information has to be converted to a position reference to control the actuator.

The signals of both pressure sensors will be subtracted. The signal of the pressure sensor placed in the strap will be positive and the one placed above the finger negative. Hence, when the finger wants to perform a closure gesture the pressure in the strap sensor will be greater than the other and the resulting signal will be positive and vice versa. So, with a positive reference signal the motor will move further and with a negative signal it will retract.

Even though the signal to control the motor is proportional to the position, the control will be based in the speed. When the pressure applied by the finger is maximum, the speed reference will be maximum and it will proportionally decrease when the pressure decreases. The maximum speed of the actuator is 13mm/s.



To convert the speed reference in a position reference, the space that the motor can move in the time that the reference is available will be calculated with *Equation (9)*. The reference will be updated during each sample period.

$$\text{Space in one period (mm)} = \text{Speed reference (mm/s)} * \text{Sample period (s)}$$

*Equation (9)*

The space calculated in each period is an increment. Therefore, a variable that saves the information of the position of the actuator is needed. The calculated space will be added to the position variable, which will be the reference that will be sent to the motor internal controller. As said before, the internal controller reference must be a voltage from 0 to 5 V, so the position reference that was in mm has to be a voltage output. A volt corresponds to 10 mm, then the conversion is simple.

This algorithm was implemented in Arduino with positive results. The exoskeleton responds effectively when the finger tries to do the closing or opening gesture, and it works smoothly and fast.

## **5 Conclusion and further developments**

The integration of the mechanical design with the sensorization and the data processing in the microcontroller has led to a functional exoskeleton prototype. However, it still needs several improvements to become a commercial and real solution to palliate the PD symptoms.

The exoskeleton structure fits in the finger and the hand, and it allows the finger to move in its normal trajectory, but the amplitude of the movement is restricted. The actuator transmits the calculated force to the finger.

However, in future researches the force transmission from the actuator to the linkages of the finger structure can be maximized with advanced mechanical design methods. In addition, the ergonomics of the exoskeleton can be enhanced to make it more comfortable and improve the daily life of the patient while wearing the exoskeleton. Just one finger has been designed in this prototype, but the design of the remaining fingers will follow the same methodology.

The pressure sensors can detect the pressure applied by the finger and the tremors. This is one of the most critical points of the prototype. Even though the pressure is detected, the used pressure sensor is not made specifically for this application. The development of a custom

pressure sensor could improve the ergonomics, sensibility and precision of the sensor, improving the final result.

The exoskeleton does not have a sensor that detects if the patient is grabbing an object. This should be the next step in the development of the prototype because it will increase the safety of the exoskeleton. If the patient is grabbing an object, the actuator should not try to push more and try to move because it can be harmful to the patient. This sensor is indispensable to ensure the safety of the patient. In addition, when an object is grabbed some pressure is transmitted to the pressure sensor placed in the strap, which degrades the measuring. It is useful to detect that to know that the information of the sensor is not correct, because if not the control of the actuator could be degraded. To detect the grabbing another pressure sensor placed outside the exoskeleton can be used. However, other alternatives like proximity sensors are valid.

The data treatment done by the microcontroller had positive results. The pressure sensor signal treatment was effective, and it removed the frequency components of the signal where the PD tremors are present. This was crucial to suppress the PD tremors with the actuator. The control of the actuator to move the finger was reliable. A future research proposal is to use all the data collected by the sensors and analyze it to extract medical information about the postural behaviour of the patient or the frequency of the tremors. This can help the doctors to study the personal conditions of each patient and diagnose and treat the patient with more accuracy.

The constructed exoskeleton was a prototype. In order to make the exoskeleton a commercial device, it will have to be compact and portable. A power source and the microcontroller must be integrated into the hand, among the actuators. Also, the high number of sensors present in the exoskeleton would need numerous wires, which would be uncomfortable for the patient. The possibility of using the novel 3D printing techniques that combine plastic and metal conductive tracks must, at least, be considered to achieve a more compact and attractive result.

To conclude, this prototype was designed for PD patients, but it can be useful for other neuro-motor diseases or patients with reduced mobility.

# List of Figures

- Figure 1: Linear actuators 'Actuonix L12 series'.....6
- Figure 2: Finger joints [6, p. 195].....7
- Figure 3: The designed mechanism.....8
- Figure 4: Force transmission in the mechanism.....11
- Figure 5: Trajectory of the finger, without exoskeleton in the left and with exoskeleton in the right.....12
- Figure 6: Relation of the current with the force applied by the Actuonix motor [17].....13
- Figure 7: Speed relation with the force applied by the motor [17].....15
- Figure 8: Obtained data and FFT of a PD patient with the hand position parallel to the table plane (resting tremor) [2]......17
- Figure 9: Pressure sensor with a circular sensitive area.....19
- Figure 10: Voltage divider scheme.....20
- Figure 11: Resistance-force graphic of the pressure sensor [22].....21
- Figure 12: Second order section of a filter with the direct form II structure.....25
- Figure 13: Magnitude response of the low pass filter.....26
- Figure 14: Test original data.....27
- Figure 15: Results of the filter implemented in Arduino.....28
- Figure 16: Results of the filter designed in MATLAB.....29

# List of Equations

- Equation (1).....9
- Equation (2).....9
- Equation (3).....11
- Equation (4).....21
- Equation (5).....21
- Equation (6): Nyquist-Shannon theorem.....24
- Equation (7).....26
- Equation (8).....26
- Equation (9).....30

## List of Abbreviations

DLA	Daily Life Activities
DOF	Degrees Of Freedom
CAD	Computer Aided Design
MCP	Metacarpophalangeal
PIP	Proximal interphalangeal
DIP	Distal interphalangeal
SLS	Selective Laser Sintering
PD	Parkinson Disease
ADC	Analog to Digital Converter
PTF	Polymer Thick Film

## A: PART'S DRAWINGS

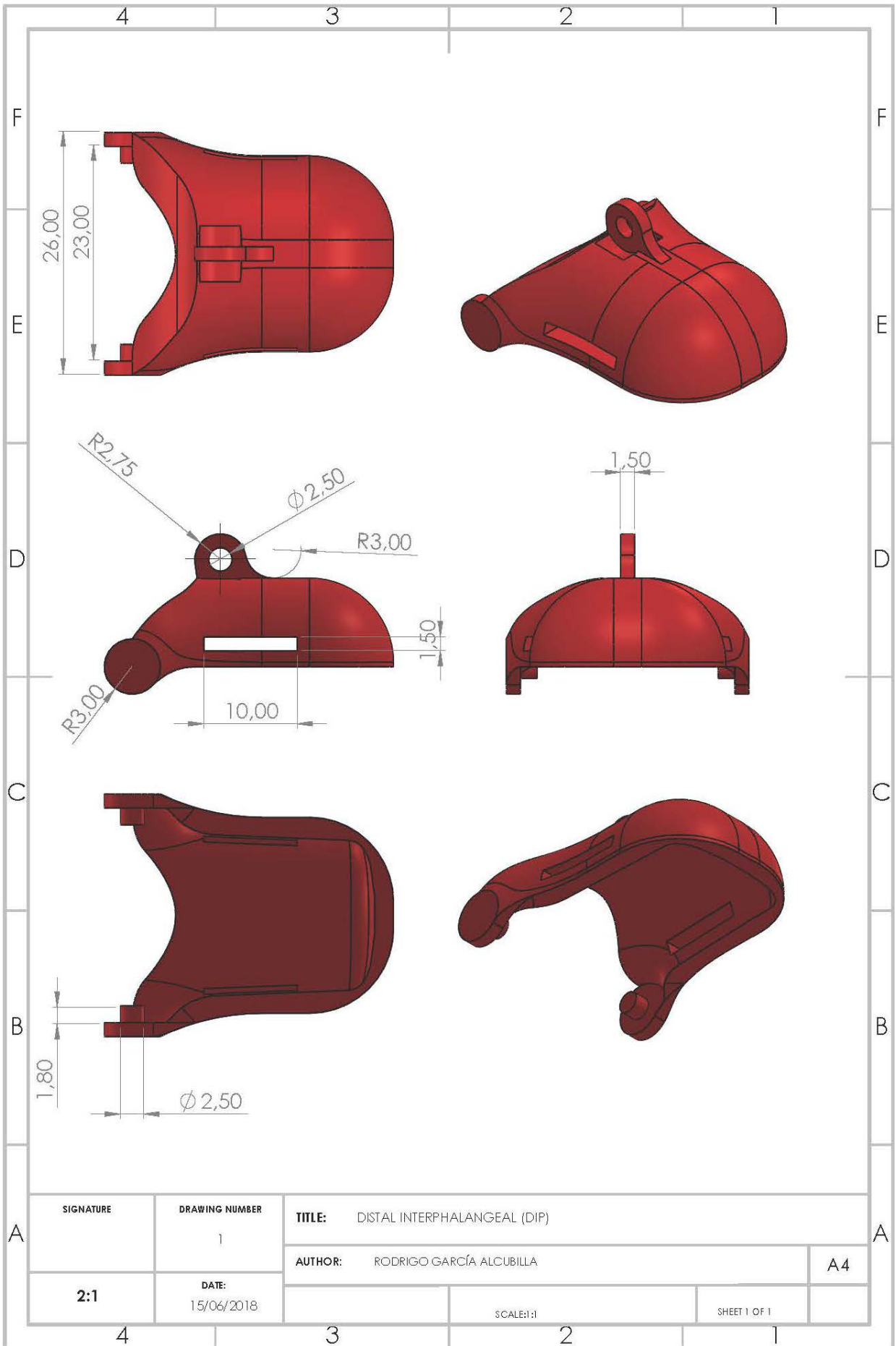

A	SIGNATURE	DRAWING NUMBER	TITLE: DISTAL INTERPHALANGEAL (DIP)		A
		1	AUTHOR: RODRIGO GARCÍA ALCUBILLA		
	2:1	DATE:		SCALE:1:1	A4
		15/06/2018		SHEET 1 OF 1	

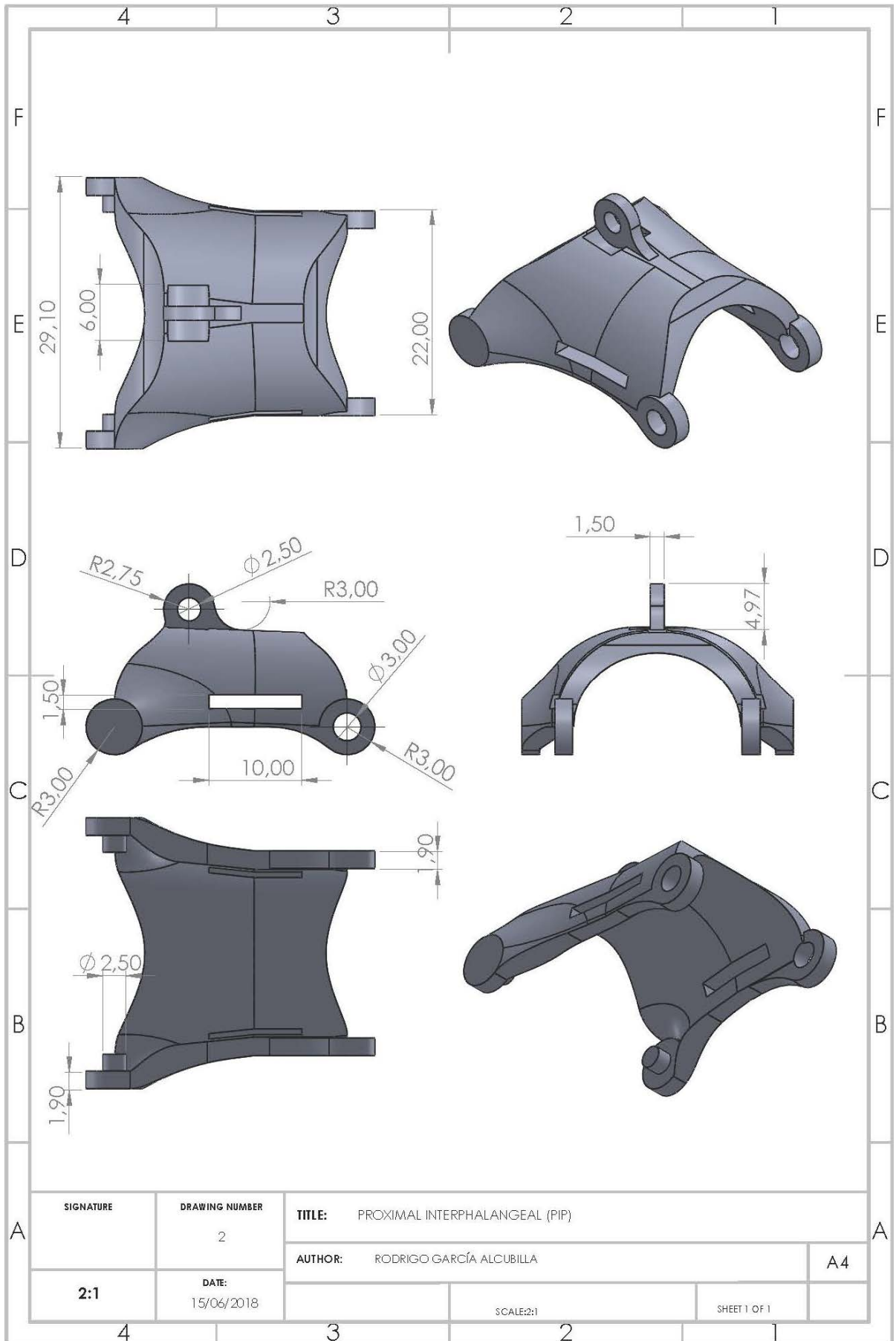



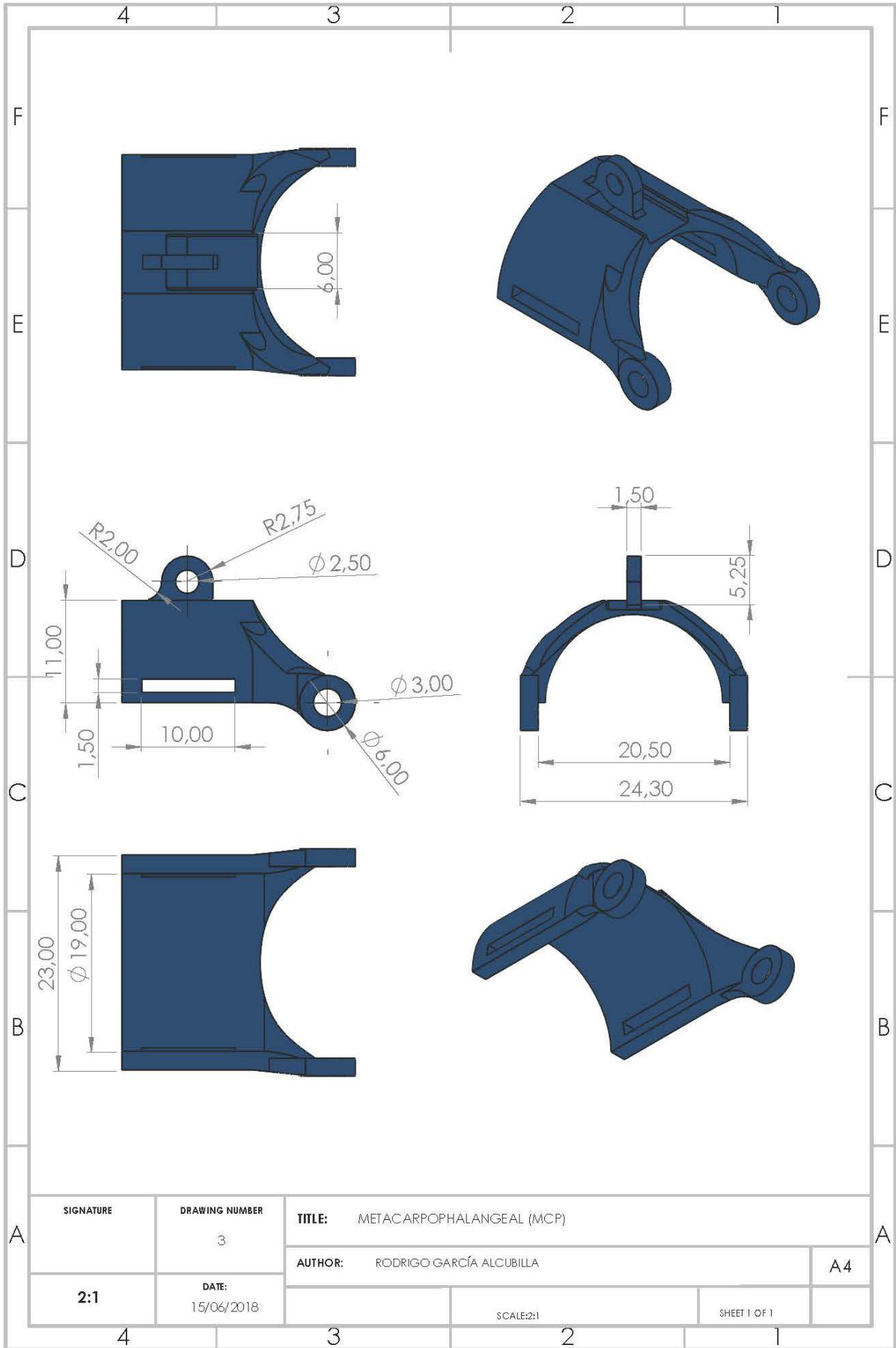

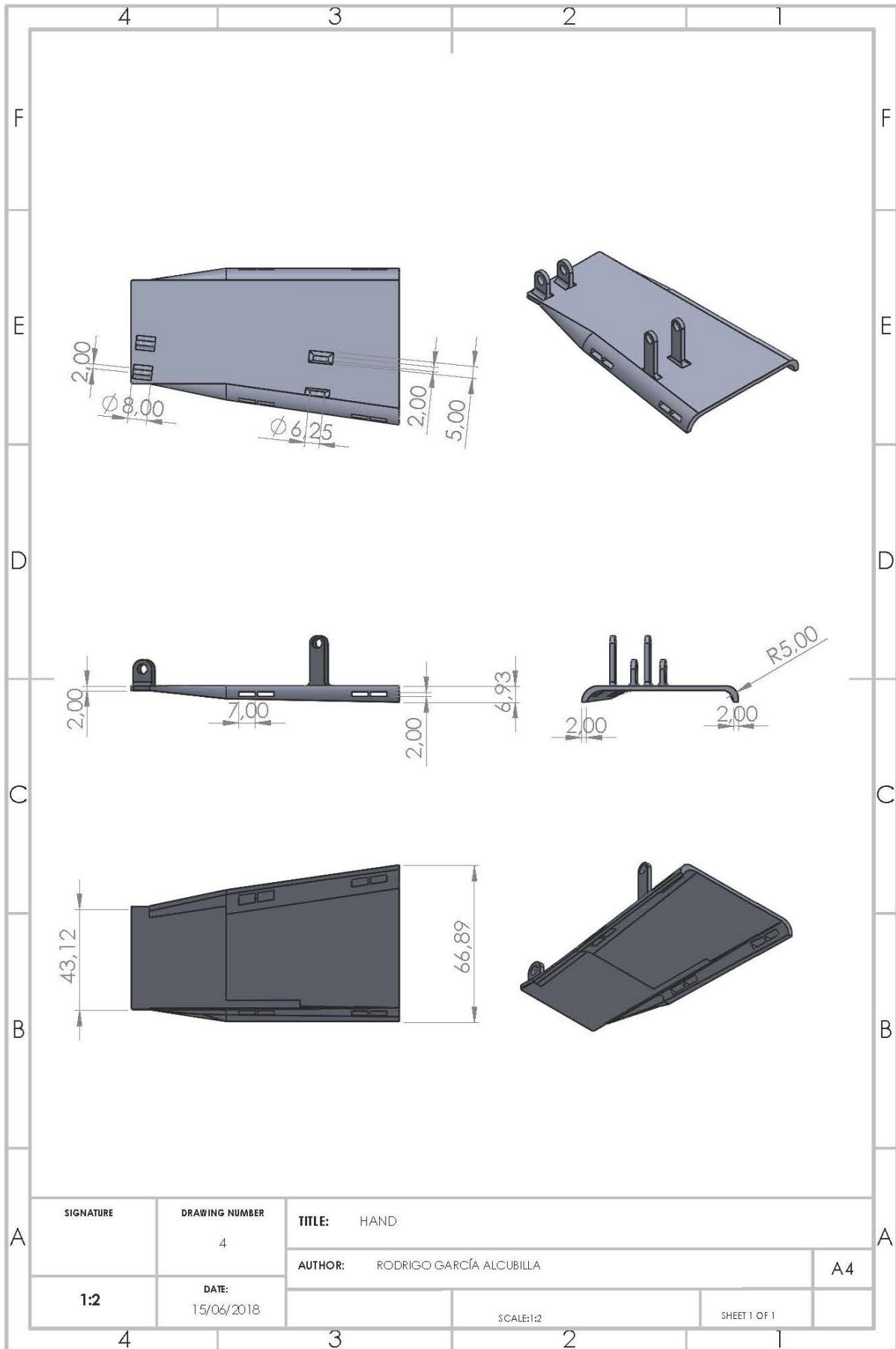



SIGNATURE	DRAWING NUMBER 5	TITLE: LINKAGES 1, 2, 3	
		AUTHOR: RODRIGO GARCÍA ALCUBILLA	
2:1	DATE: 15/06/2018	SCALE:2:1	
		SHEET 1 OF 1	



LINKAGE 4

LINKAGE 5

SIGNATURE	DRAWING NUMBER 6	TITLE: LINKAGES 4,5	
		AUTHOR: RODRIGO GARCÍA ALCUBILLA	
2:1	DATE: 15/06/2018	SCALE: 2:1	SHEET 1 OF 1

## B: Arduino code

```
int pin_inferior=A0;
int pin_superior=A1;
int pin_motor=6;
int pin_position=A3;

#define SAMPLING_FREQUENCY 1000 //Hz, must be less than 10000 due to
ADC

unsigned int
sampling_period_us=round(1000000*(1.0/SAMPLING_FREQUENCY));
int previous_time=micros();

int Xinf_readdata=0;
double Xinf;
double Xsup;
double inf_offset=0;
double sup_offset=0;

//filter parameters (3 sections)
double V1sup[3] = {0,0,0};
double *V1supptr=&V1sup[0];
double V2sup[3] = {0,0,0};
double *V2supptr=&V2sup[0];
double V3sup[3] = {0,0,0};
double *V3supptr=&V3sup[0];

double V1inf[3] = {0,0,0};
double *V1infptr=&V1inf[0];
double V2inf[3] = {0,0,0};
double *V2infptr=&V2inf[0];
double V3inf[3] = {0,0,0};
double *V3infptr=&V3inf[0];

double sp1[6] = {1, 2, 1, 1, -1.98851661825035, 0.988972985409237};
double sp2[6] = {1, 2, 1, 1, -1.96970656121125, 0.970158611437496};
double sp3[6] = {1, 2, 1, 1, -1.95900772818593, 0.959457323016034};
double k1 = 0.000114091789720989;
double k2 = 0.000113012556561633;
double k3 = 0.000112398707526336;

//filter outputs
double Yinf;
double Ysup;

//control variables
double actual_position;
double reference;
double mean_reference=0;
double given_position=0;
```

```

double increment=0;
double Yinf_ref;
double Ysup_ref;
int cont_control=0;

void setup() {

    Serial.begin(115200);

    pinMode(pin_motor,OUTPUT);
    voltage_control(0);
    ///JUST 8 SIGNIFICANT NUMBERS ALLOWED IN ARDUINO :(

    //HERE I WILL DO THE CALIBRATION TO REMOVE OFFSET

    //2 seconds of delay untill starts
    delay(2000);

    //the mean value it's the offset (NOT FILTERING HERE I THINK)

    //I will do the calibration during 6 seconds
    int count=0;
    int calibration_samples=SAMPLING_FREQUENCY*6;

    while (count < calibration_samples)
    {
        if(micros() > (previous_time + sampling_period_us))
        {

            previous_time=micros();
            Xinf=analogRead(pin_inferior);
            Xsup=analogRead(pin_superior);

            //add all the data in one variable
            sup_offset=sup_offset+Xsup;
            inf_offset=inf_offset+Xinf;

            count++;
        }
    }

    //divide all the data for the number of samples to get the mean
    sup_offset=sup_offset/calibration_samples;
    sup_offset=(sup_offset*5)/1024;//pass to volts
    /*Serial.print("Superior offset in volts: ");
    Serial.println(sup_offset);*/

    inf_offset=inf_offset/calibration_samples;
    inf_offset=(inf_offset*5)/1024;
    /*Serial.print("Inferior offset in volts: ");
    Serial.println(inf_offset);*/

}

```

```

void loop() {
  // put your main code here, to run repeatedly:
  /*SAMPLING*/

  if(micros() > (previous_time + sampling_period_us))
  {
    previous_time=micros();

    //sampling
    Xinf=analogRead(pin_inferior);
    Xsup=analogRead(pin_superior);

    //filtering inferior sensor signal
    Xinf=(Xinf*5)/1024;//first pass to volts
    Xinf=Xinf-inf_offset;//subtract the offset

    Yinf = direct_formII_section(Xinf,sp1,k1,V1infptr);
    Yinf = direct_formII_section(Yinf,sp2,k2,V2infptr);
    Yinf = direct_formII_section(Yinf,sp3,k3,V3infptr);

    //superior filtering
    Xsup=(Xsup*5)/1024;//first pass to volts
    Xsup=Xsup-sup_offset;//subtract the offset

    //filter structures
    Ysup = direct_formII_section(Xsup,sp1,k1,V1supptr);
    Ysup = direct_formII_section(Ysup,sp2,k2,V2supptr);
    Ysup = direct_formII_section(Ysup,sp3,k3,V3supptr);

    //For the reference
    Yinf_ref=Yinf*(5/2.5);//4 y 2.5 es el maximo que llega
    Ysup_ref=Ysup*(5/2.5);
    //Control of the motor
    reference=Yinf_ref-Ysup_ref;
    cont_control++;
    mean_reference=mean_reference+reference;

    //each 100 samples
    if(cont_control>100)
    {
      mean_reference=mean_reference/cont_control;

      increment=13*(mean_reference/4); //if the signal is 5 each
      if(increment>13)

```

```

    {
        increment=13;
    }
    else if (increment < -13)
    {
        increment=-13;
    }

    given_position=given_position+increment;

    if(given_position>500)
    {
        given_position=500;
    }
    else if (given_position < 0)
    {
        given_position=0;
    }

    voltage_control(given_position);
    mean_reference=0;
    cont_control=0;
}
}

}

//function [ Y,Vnew ] = direct_formII_section( X, sp,k,Vold)
double direct_formII_section(double X, double sp[6], double k,
double *Vptr)
{
    //implements one section of the direct form II in discrete
    equations
    /*inputs:
        %x is the filter input
        %sp are the section parameters (sp=[b1,b2,b3,a1,a2,a3])
        %k is the gain of the filter
    %Outputs
        %V is the vector of intermediate positions needed to solve
the filter
        %Vn needs three data V=(Vn,Vn-1,Vn-2)
        %Y is the filter output
    */
    double Vnew[3]={0,0,0};
    double Y;
    double *temp_ptr=Vptr;
    //first we need to calculate the new V(1) that is V(n), then we
have to actualize the vector

    Vnew[1]=*temp_ptr; //here temp_ptr points to same than *Vptr
that points to Vx[0], then is: Vnew[1]=Vx[0];

```



```

temp_ptr++; //know tmp_ptr points to Vx[1]
Vnew[2]=*temp_ptr; //Vnew[2]=Vx[1];

//V(n)=X(n)*k - V(n-2)*a3 - V(n-1)*a2

Vnew[0]=X*k - Vnew[2]*sp[5]- Vnew[1]*sp[4];

//Y(n)= V(n)*b1 + V(n-1)*b2 + V(n-2)*b3

Y=Vnew[0]*sp[0] + Vnew[1]*sp[1] +Vnew[2]*sp[2];
//actualize values

    *Vptr=Vnew[0]; //here *Vptr points Vx[0], then is:
Vx[0]=Vnew[0];
    Vptr++; //Vptr points to Vx[1]
    *Vptr=Vnew[1]; //Vx[1]=Vnew[1];
    Vptr++; //Vptr points to Vx[2]
    *Vptr=Vnew[2]; //Vx[2]=Vnew[2];

    /*
    Serial.print("Vl0 dentro funcion: ");
    Serial.println(Vnew[0]);
    Serial.print("Vl1 dentro funcion: ");
    Serial.println(Vnew[1]);*/

    return Y;
}

void voltage_control(int posicion)
{
    int value; //between 0 and 255 to PWM write

    value=map(posicion,0,500,0,255); //map(value, fromLow, fromHigh,
toLow, toHigh)

    analogWrite(pin_motor,value);
}

```

## Bibliography

- [1] N. Ferenčík, M. Jaščur, M. Bundzel, and I. Zolotová, Eds., *Measurement of hand tremors*. 2018 IEEE 16th World Symposium on Applied Machine Intelligence and Informatics (SAMI), 2018.
- [2] Y. Zhou, M. E. Jenkins, M. D. Naish, and A. L. Trejos, Eds., *The measurement and analysis of Parkinsonian hand tremor*. 2016 IEEE-EMBS International Conference on Biomedical and Health Informatics (BHI), 2016.
- [3] F. L. Xu *et al.*, Eds., *Development of a closed-loop system for tremor suppression in patients with Parkinson's disease*. 2016 38th Annual International Conference of the IEEE Engineering in Medicine and Biology Society (EMBC), 2016.
- [4] R. A. Bos *et al.*, "A structured overview of trends and technologies used in dynamic hand orthoses," *J NeuroEngineering Rehabil*, vol. 13, no. 1, p. 807, 2016.
- [5] A. Wege and G. Hommel, Eds., *Development and control of a hand exoskeleton for rehabilitation of hand injuries*. 2005 IEEE/RSJ International Conference on Intelligent Robots and Systems, 2005.
- [6] R. Conti, E. Meli, and A. Ridolfi, "A novel kinematic architecture for portable hand exoskeletons," *Mechatronics*, vol. 35, pp. 192–207, 2016.
- [7] N. S. K. Ho *et al.*, Eds., *An EMG-driven exoskeleton hand robotic training device on chronic stroke subjects: Task training system for stroke rehabilitation*. 2011 IEEE International Conference on Rehabilitation Robotics, 2011.
- [8] I. Jo and J. Bae, Eds., *Design and control of a wearable hand exoskeleton with force-controllable and compact actuator modules*. 2015 IEEE International Conference on Robotics and Automation (ICRA), 2015.
- [9] R. Ismail, M. Ariyanto, K. A. Pambudi, J. W. Syafei, and G. P. Ananto, Eds., *Extra robotic thumb and exoskeleton robotic fingers for patient with hand function disability*. 2017 4th International Conference on Electrical Engineering, Computer Science and Informatics (EECSI), 2017.
- [10] Festo, *Exo-Hand: New scope for interaction between humans and machines*. [Online] Available:  
[https://www.festo.com/net/SupportPortal/Files/156734/Brosch\\_FC\\_ExoHand\\_EN\\_lo\\_L.pdf](https://www.festo.com/net/SupportPortal/Files/156734/Brosch_FC_ExoHand_EN_lo_L.pdf).

- [11] M. DiCicco, L. Lucas, and Y. Matsuoka, Eds., *Comparison of control strategies for an EMG controlled orthotic exoskeleton for the hand*. Robotics and Automation, 2004. Proceedings. ICRA '04. 2004 IEEE International Conference on, 2004.
- [12] H. K. Yap, Jeong Hoon Lim, F. Nasrallah, J. C. H. Goh, and R. C. H. Yeow, Eds., *A soft exoskeleton for hand assistive and rehabilitation application using pneumatic actuators with variable stiffness*. 2015 IEEE International Conference on Robotics and Automation (ICRA), 2015.
- [13] B. W. K. Ang and C. H. Yeow, Eds., *Print-it-Yourself (PIY) glove: A fully 3D printed soft robotic hand rehabilitative and assistive exoskeleton for stroke patients*. 2017 IEEE/RSJ International Conference on Intelligent Robots and Systems (IROS), 2017.
- [14] S. S. Yun, B. B. Kang, and K. J. Cho, "Exo-Glove PM: An Easily Customizable Modularized Pneumatic Assistive Glove," *IEEE Robotics and Automation Letters*, vol. 2, no. 3, pp. 1725–1732, 2017.
- [15] L. Randazzo, I. Iturrate, S. Perdakis, and J. d. R. Millán, "mano: A Wearable Hand Exoskeleton for Activities of Daily Living and Neurorehabilitation," *IEEE Robotics and Automation Letters*, vol. 3, no. 1, pp. 500–507, 2018.
- [16] S. Derler and L.-C. Gerhardt, "Tribology of Skin: Review and Analysis of Experimental Results for the Friction Coefficient of Human Skin," *Tribol Lett*, vol. 45, no. 1, pp. 1–27, 2012.
- [17] Actuonix, *L12 miniature series: Datsheet*. [Online] Available: <https://s3.amazonaws.com/actuonix/Actuonix+L12+Datasheet.pdf>.
- [18] R. G. Garcia *et al.*, Eds., *Hand tremor analyzer using accelerometry for preliminary diagnosis, classification and monitoring of selected movement disorders*. 2016 6th IEEE International Conference on Control System, Computing and Engineering (ICCSCE), 2016.
- [19] H. J. Luinge, P. H. Veltink, and C. T. M. Baten, "Ambulatory measurement of arm orientation," (eng), *Journal of biomechanics*, vol. 40, no. 1, pp. 78–85, 2007.
- [20] L. Plant, B. Noriega, A. Sonti, N. Constant, and K. Mankodiya, Eds., *Smart E-textile gloves for quantified measurements in movement disorders*. 2016 IEEE MIT Undergraduate Research Technology Conference (URTC), 2016.
- [21] M. Bravo *et al.*, Eds., *A system for finger tremor quantification in patients with Parkinson's disease*. 2017 39th Annual International Conference of the IEEE Engineering in Medicine and Biology Society (EMBC), 2017.
- [22] Interlink electronics, *FSR400 series integration guide*. [Online] Available: <https://www.generationrobots.com/media/FSR400-Series-Integration-Guide.pdf>.