



Universidad de Valladolid



**ESCUELA DE INGENIERÍAS
INDUSTRIALES**

UNIVERSIDAD DE VALLADOLID

ESCUELA DE INGENIERIAS INDUSTRIALES

**Grado en Ingeniería en Diseño Industrial y Desarrollo de
Producto**

Título del TFG:

FRAME

Autor:

Manzano Castellanos, Celia

Responsable de Intercambio en la Uva:

Sánchez Bascones, María Isabel

Universidad de destino:

OsloMet- Oslo Metropolitan University

Valladolid, Julio 2018.

TFG REALIZADO EN PROGRAMA DE INTERCAMBIO

TÍTULO: FRAME

ALUMNO: Celia Manzano Castellanos

FECHA: 12.04.2018

CENTRO: OsloMet- Oslo Metropolitan University

TUTOR: Vibeke Skarsjø Hansen

RESUMEN

Este proyecto está centrado en mostrar todo el proceso de diseño para concebir un “collapsible space” para los colectivos apasionados por el montañismo. Se muestra paso por paso como a través de métodos de observación etnográficos e investigación como se consigue ganar conocimiento y entender al grupo cultural. Después de esto se analiza la información obtenida y se desarrolla un producto con el que los usuarios se sentirán identificados.

El objeto entendido como “collapsible space” consiste en un rediseño de los grips tradicionales de escalada para mejorar su estética y conseguir un híbrido entre pieza de arte y herramienta de entrenamiento. Se consigue así un producto para entrenar en casa que a la vez sirve como elemento decorativo.

PALABRAS CLAVE

REDISEÑO, MONTAÑISMO, COLLAPSIBLE SPACE, GRIPS, ENTENDIMIENTO CULTURAL



Projectt report of FRAME by Oddmund Lilletofte, Stian Lüneberg & Celia Manzano Castellanos

INDEX

- Page 1 Abstract & Introduction
- Page 2 Background - Self mapping journey
- Page 3 Background - choice of the cultural group
- Page 4 Background - why climbers?
- Page 5 Design process
- Page 6 Research phase - looking ahead and observe
- Page 7 Research phase - looking ahead and observe
- Page 8 Research phase - looking ahead and observe
- Page 9 Research phase - empathize
- Page 10 Research phase - interviews
- Page 11 Research phase - personas
- Page 12 Research phase - mountaineers society
- Page 13 Ideation concepts
- Page 14 Ideation concepts
- Page 15 Iteration phase - personal survey to climbers
- Page 16 Iteration phase - attachable piece to the wall
- Page 17 Iteration phase - attachable piece to the wall
- Page 18 Iteration phase - climbing furniture
- Page 19 Iteration phase - apartment
- Page 20 Iteration phase - feedback from climbers
- Page 21 Iteration phase - rapid prototyping
- Page 22 Implementation phase - final product and material decision
- Page 23 Implementation phase - different sizes
- Page 24 Implementation phase - why our product relates to art
- Page 25 Implementation phase - why the product is a good training system
- Page 26 Implementation phase - mounting system
- Page 27 Implementation phase - branding and naming
- Page 28 Implementation phase - packaging
- Page 29 Result of design process
- Page 30 Result of design process
- Page 31 Result of design process
- Page 32 Result of design process
- Page 33 Communication - semiotics
- Page 34 Communication - exhibition design
- Page 35 Communication - exhibition design
- Page 36 Communication - web design
- Page 37 Communication - Presentation
- Page 38 Conclusion
- Page 39 Image references
- Page 40 Appendix

ABSTRACT

This report is focused on showing the whole process of designing a meaningful collapsable space for mountaineers. Going step by step throughout the process, showing ethnographic observation methods and research exercises we have performed to gain knowledge and understanding of the cultural group. By analyzing information gained from these methods, and going forth with developing the product, the report ends with an product that is significant in its way of enlighten and cover the unsaid. This is within a course that teaches cultural understanding, communication and presentation.

INTRODUCTION

Starting this semester with the course of cultural understanding, communication and presentation we were assigned with the task of developing a collapsable space for a cultural group. This report guides through the design process, starting with the deciding of mountaineers as the target group, going through all the phases, methods and exercises used to obtain information, knowledge and understanding about the group. Analyzing this information leads towards sketched ideas that evolves further into a product that covers some of the missing pieces in their daily life.

By the lengthy process of insight and observation of the mountaineers it came clear that nature, outdoor activities and the wilderness has a high value. Including the cultural group in our process to get feedback and to keep every part of the process up to date. Going forward with this, further focusing on giving better fitting solutions to existing problems and still adding features that cover an area of the unsaid. While the people within the group came forward as strong individuals, the process led to a product that give them an opportunity to express this by having freedom to choose within a set of rules

BACKGROUND

SELF MAPPING JOURNEY

This was the very first beginning of the project. We created a selfmap to situate us as a person. The goal was to show to the rest of the class what we are, what we not are and what are the things we do not even talk about. It was a free exercise to define our person in a nice graphic. The main purpose of this was trying to understand our world and search for a common pattern on the things we are not with classmates.

That helped the class find a cultural group they are not into it, a basic requirement for the course of Cultural Understanding, Communication and Presentation.

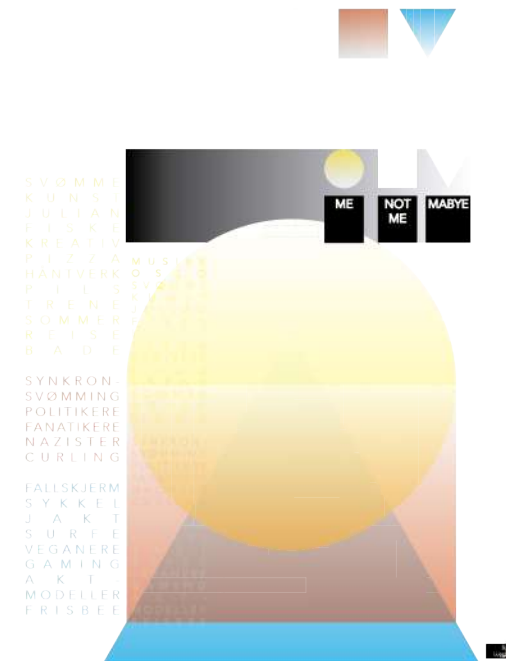
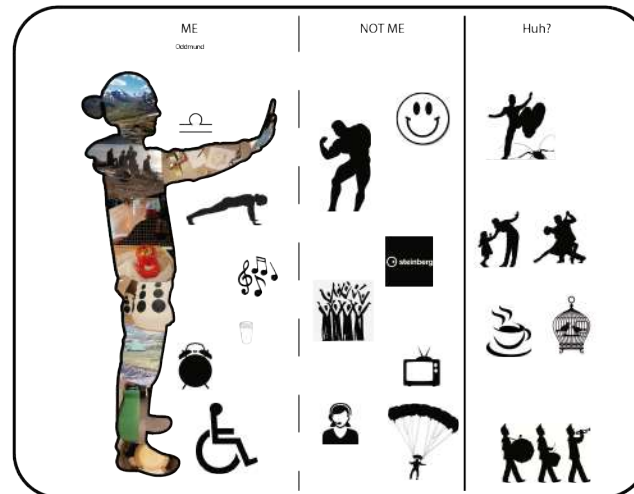
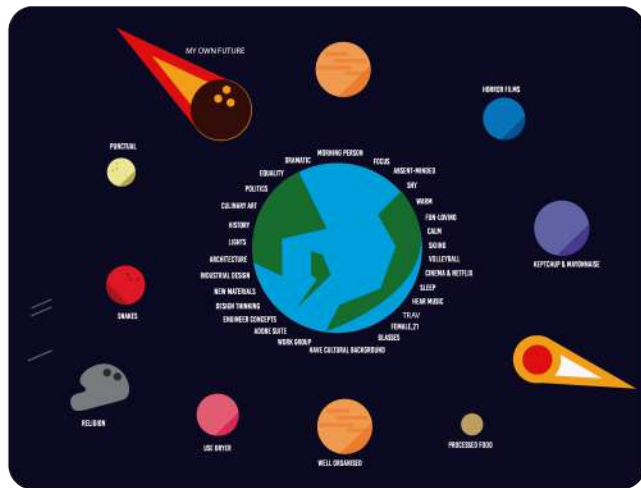

Fig 1. Celia's a Oddmund's selfmap for the exercise.

BACKGROUND

CHOICE OF THE CULTURAL GROUP

After we had the selfmapping exercise, as shown in the previous page, we chose which ones in class were going to work together as a group. Later, when all the groups were created, everyone started to decided the cultural group they want to work in.

Oddmund, Stian and myself (later in the text referred as our group) used the method of brainstorming and listed different cultural groups neither of us had any connection to, and we all found interesting.

As we worked with this we sorted out the different groups we found difficult to work with, and those with more potential.

The discussion led us to four main groups and further on, the choice of cultural group.

POTENTIAL GROUPS

CLIMBERS

BARISTAS

MIX MARTIAL ARTS

SKATEBOARDERS

FACTS FOR CHOICE

EASY-GOING PEOPLE

NO CONNECTION WITH US

A GROUP WE MAYBE COULD BE PART OF

EASY TO VISIT THEIR ENVIROMENT

ENDED UP WITH CLIMBERS

BACKGROUND

WHY CLIMBERS?

The climbing community in Norway has changed a lot over the years. From the start where the climbers practiced free climbing, often of practical reasons to get around and usually with equipment like hemp rope, ice ax and boots fixed with nails (Larsen, Hohle, Bryhn, 2017), until today where it is many different subgroups within climbing. From the extremes of ice climbing to the family and training friendly part of it that you will find in climbing centers around in Norway. This is followed by climbing being a more popular activity in the community and therefore it is being built more centres around in Norway. Which is also because the weather in Norway makes the outdoor climbing a bit risky at times (Norges Klatreforbund [NKF], Undated). While visiting one of the climbing centres in Oslo, Vulkan klatresenter, we got some interesting information from one of the workers who said, "One of the problems with indoor climbing is to keep the experience interesting" (E. Ohlsson, personal communication, 30. january 2018). He referred to the active climbers that rather travel to warmer countries in the Norwegian winter season to climb. This fits one of the core values of Norges Klatreforbund: their main focus is not to engage new climbers, but to facilitate to the already existing climbers, and those who joins along the way. This goes for children, professionals, paraclimbers and free time climbers.

In our research we came across a group who said they have not had such a big dividend of the climbing centres. They dont associate themselves with the other climbers, and are not really fund of going to noisy and crowded climbing halls. This is the subgroup within climbing called mountaineers. A group with strong individuals that has many of their principles and values in common. From what they said in our interviews, we understood that they are the ones closest to the traditional Norwegian climbing. This conclusion is based on that they still practise the philosophy of untraceable traffic in nature, and combines rough climbing with long hiking trips.

They travel overboards once or twice a year to hike and climb, and while being in Norway in the meantime they need to maintain strenght and technique.



Fig 2. Arne Næss practicing climbing. Retrieved from: <https://www.norsk-klating.no>

DESIGN PROCESS

When we started this project, the knowledge about mountaineers we had was about equal to none. So because of that it is really important to be based on a well constructed designed process and design techniques. In the graph it is shown a previous sketch of the steps we wanted to follow. But as the designers we are, we know that for creating a good product that really fits the user you are designing for, we need to go back and forth in the process.

Due to the fact of not having any type of contact with the climbers, we decided to do an exhaustive research on which their habits, routines and likes are, and what defines them as a cultural group. We used different methodologies such as: interviews, market survey and personas to obtain that information.

In this phase we became aware of how big the climbing world is. That it is why we rethought our cultural group and narrowed down to mountaineers, which was the cultural group we felt more attracted by. This attraction is full with the traditions they have and how they talked to us so passionate about their "hobby".

After getting deep in their world, the other phases of the process came along. As a result we got the final product and a great amount of learning of how to deal with a user you don't know anything about.

Also all of us learned a new concept to work with: collapsible space. This should be a bit confuse at first time, but then it becomes more natural to talk and know what it is. Just as a little introduction, for our group collapsible space is abstract. With this we try to say that our product is between two different worlds, collapsing imaginary

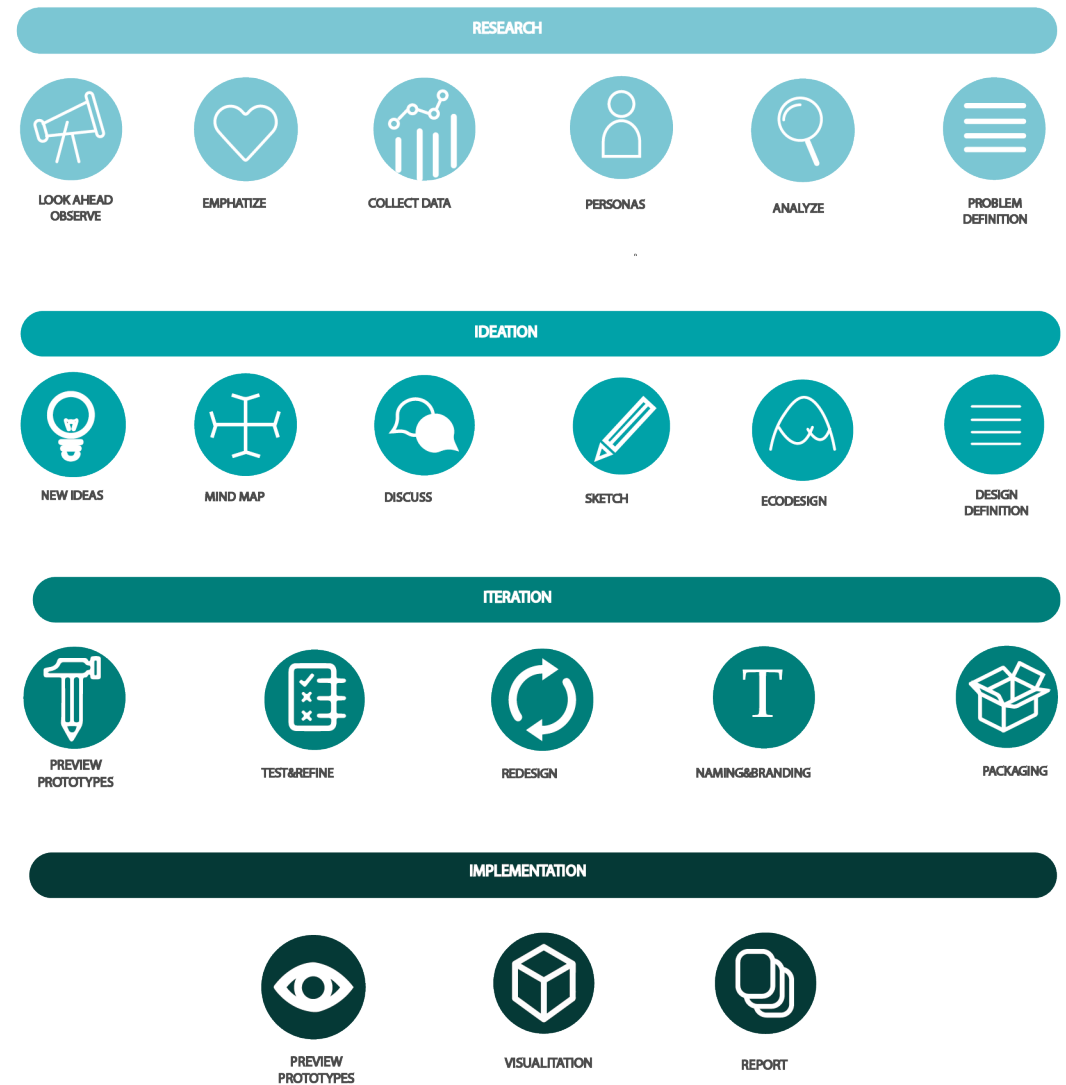

Fig 3. Graphic of our previous design process. Illustration by Celia Manzano

RESEARCH PHASE

LOOKING AHEAD & OBSERVE

After desiding which cultural group to work with, we went further on with our research. We charted the different groups that exist within climbing and chose to look further into the potential ones. Here it is shown a breve summary of the most potential discipline.

INDOOR BOULDRING

Indoors and outdoors climbing without safety gear, climbing shoes and chalk as the only equipment.



Fig 4. Indoor bouldring.
Retrieved from:
<https://en.wikipedia.org/wiki/Bouldering>

TRAD CLIMBING

Climbing where you need to find your own way to the top and secure yourself as you climb.



Fig 5. Trad climbing. Retrieved from:https://readtiger.com/wkp/en/Traditional_climbing

ICE CLIMBING

This is done on frozen waterfalls with more gear than the other climbing groups, including ice axes, crampons and titanium



Fig 6. Ice climbing. Retrieved from:https://it.wikipedia.org/wiki/File:Canadian_Rockies_-_Oh_le_tabernacle.jpg

SPORT CLIMBING

Climbing that differs from traditional climbing because you use already fixed bolts to hang fasten your safety gear as you



Fig 7. Sport climbing. Retrieved from:<http://www.fanrto.com/to pics/rock-climbing-sport.html>

MOUNTAINEERING

Mountain climbing, often includes hiking to reach mountaintops. Could last for days and therefore includes more equipment



Fig 8. Mountaineering. Retrieved from:<https://patfalvey.com/product/island-peak-everest-base->

RESEARCH PHASE

LOOKING AHEAD & OBSERVE

At the same time we created a stereotype for our study group This was useful, because is where we expressed our feelings and preideas. Figuring out this character helped us to thrown away some preconceived ideas later in the process.



Fig 9. Graphic of our stereotype charecter Illustration by Celia Manzano

RESEARCH PHASE

LOOKING AHEAD & OBSERVE

Also we went to some sports shops to look up at technical equipment. Climbers have pretty wide variety of equipment and brands that develop specific products for them. Thus, it is really important to do a good market survey to know what already exist and what could be improved.

From this insight we can extrapolate some facts: climbing brands usually use bright colors for the gear; there is a lot of stuff you need if you want to go up in a mountain for a couple of days; mostly climbing it is an expensive sport.



Helmets for climbing, and fingerboards in the back meant for training and warm-up.

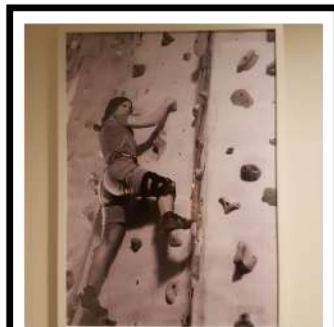

Picture on Ortopedisk verksted. Showing a knee orthosis in use while climbing.



Showing two different carabiners at top and two different nuts at the bottom.



Showing a set of nuts with different colors to make it easy to recognize the different sizes.



Self-braking descender from Petzl, only made for right-handed people.

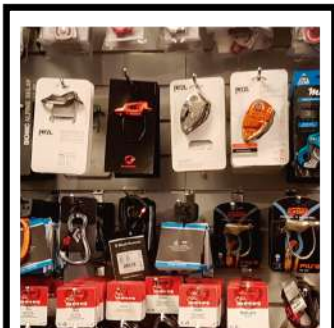

Different descenders and carabiners, also showing some of the largest brands within climbing gear.



Different ropes. No hard edges. No tight knots.

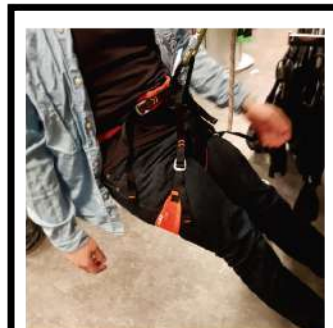

Stian sitting in a climbing harness. Uncomfortably the belt is gnawing against the back.



The harness showing its many possibilities of carrying extra gear, for example helmet and chalk bag.



Climbing shoes. Some of the most expensive equipment and also what is needed to be replaced most often.

Fig 10. Photographs from Sportslageret. Photos by Oddmund Lilletofte

RESEARCH PHASE

EMPATHIZE

Following our first contact with this world, we decided to immerse ourselves a little bit more practising this amazing sport. In order of that we resorted to Torshov klattersenter to practise some bouldering. Our group chose this discipline because we were not allowed to practise roped climbing for the reason that it is mandatory to must have a safety course before.

Anyway some of the persons in the climbing center, explained us how it works the buddy-check and how to tie a good knot to be secure. This is basic knowledge you need to have to be part of this community. It is really important to have conscience of safety and the risk it

About our experience, we could feel the pain in our non trained forearm and fingers. The used of talcum powder really helped us to have a better grab. Anyway we agreed that it is a worth experience, at least just for trying and be in the skin of a climber. It gives us knowledge about important things that influence the climb that we could never understand without doing this.

As a conclusion we can say that we were fascinated about how much strength and flexibility it is necessary to confront a not difficult path, so training is actually really important to achieve mountaineers' goals and dreams.



Fig 11. Oddmund, Stian and Celia practising bouldering. Photos by Oddmund Lilletofte and Celia

RESEARCH PHASE

INTERVIEWS

This step is probably the most important in our research phase. It is our main source of wisdom. We did an ethnographic investigation with our individuals, trying to make them speak about not only climbing world but also their experiences, feelings and daily life. Paying attention to their body language and not only to what they were saying gave us a different point of view. We obtained important data from non spoken language such as how different grips were faced or how they really feel essential confidence with their partner.

The most important data of the mountaineering individuals interviews is shown here (If you want to see more information look appendix 1). We discovered after interviews that our individuals did not differ a lot in the not physical characteristics. Probably because the stereotype of mountaineers is not that far from

As a form of visualization, we created based on those interviews personas (see next page). The goal of this is represent all the different user types and user's needs in climbing community. Personas examine the emotions and make an easy classification for designers to know how the society would react to a product.

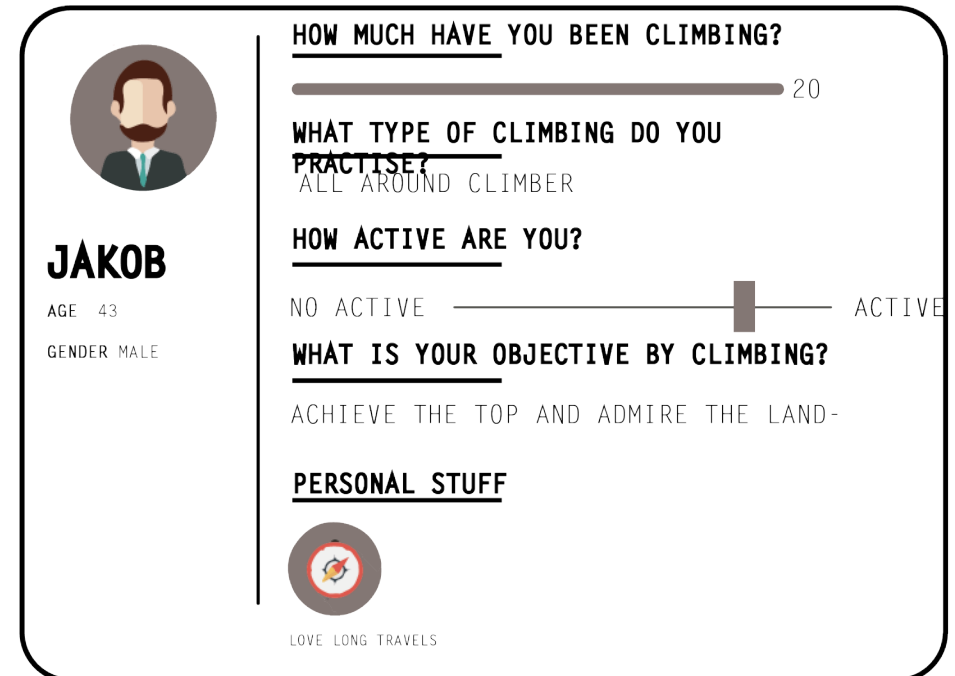

Fig 12. Illustration showing the basic data we collected from individuals. Illustrations by Celia

RESEARCH PHASE

PERSONAS

STRAIGHT PERSONA

MARIA
33

RESERVED
FRIENDLY
TECHNICAL
ENGAGED W/ COMMUNITY
ECOCONSCIOUS
PRUDENT

SHE WOULD BUY SOMETHING
ECOLOGICAL&USEFUL

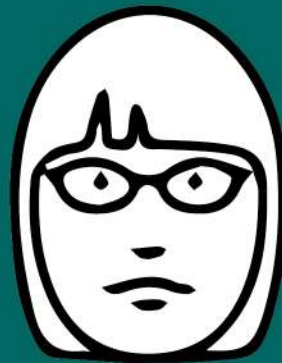

ROBERT
37

FRIENDLY
CLOSER
TECHNICAL
HATE CROWDED PLACE
LOVES LONG TRIPS
LOVES CHALLENGE

HE WOULD BUY SOMETHING
GOOD DESIGNED&INSPIRING

MOUNTAINEER PERSONA

INDOOR CLIMBING PERSONA

SIGRID
25

CRAZY
LOVES TRENDY
SPORT CLIMBER
EXPENSIVE OUTFIT
LOVES MEETING NEW PEOPLE
EXPENS

SHE WOULD BUY SOMETHING
GOOD LOOKING&NEW IN THE
MARKET



JOHN
32

EASY-GOING
RELAXED
WORK W/ CLIMBING
LOVES EXCITEMENT
ALL CLIMBING
PASSIONATE
PLAYFUL

HE WOULD BUY SOMETHING
COLL. NEW & ENTERTAINED

HIPPIE PERSONA

RESEARCH PHASE

MOUNTAINEERS SOCIETY

After analyzing research phase. It came up that climbers community is quite big, with different styles and conception of what means to be a climber. In mountaineers, our group found out that they looked a bit as how we imagined them.

This made us think and invited us to narrow down our cultural group choice. Also due to the fact that mountaineers often combine or practise many of the different branches within climbing. And that is what we did, we choose mountaineers. Their world seemed to be more closer to our ideology of what a climber is. In addition there is more field to cover and more people to join in our process.

Despite everything mountaineers think about themselves, they are a complex and well-defined society. Maybe this concept could sound too hard, but actually they have their own way of communication and have created different knowledge and behaviors around what at first was a hobby. The graphic shows the common interest for member of this society.

This led to remade the problem definition:

What is seen as most important in the mountaineering community, and is there a way to improve their experience?



Fig 13. Illustration showing the mountaineering community. Illustration by Stian Luneberg

IDEATION CONCEPTS

In our ideation phase we ended up with four main concepts: training, combining gear, economy and social. It is appreciated in the graphic the different ideas we thought to explore in the different fields. Also in appendix 2, it appears some quickly sketches about the different ideas.

The first concept, and the one it is continue worked on this report is training. Training is a basic in every sport, but for a person who loves going outdoors and enjoy nature does not seems nice to go one over and over to the same place. Basically, even if our interviewer was not mountaineer, they claim climbing center is boring and annoying sometimes. That is because it is a repetitive action. So it seemed like a good way to start, trying to found out new forms to improve the experience of training. Our group tried to ideate some nice accesories to the climbing center, but we did not where collapsible space took place there.



SOLE CHANGING
SHOES

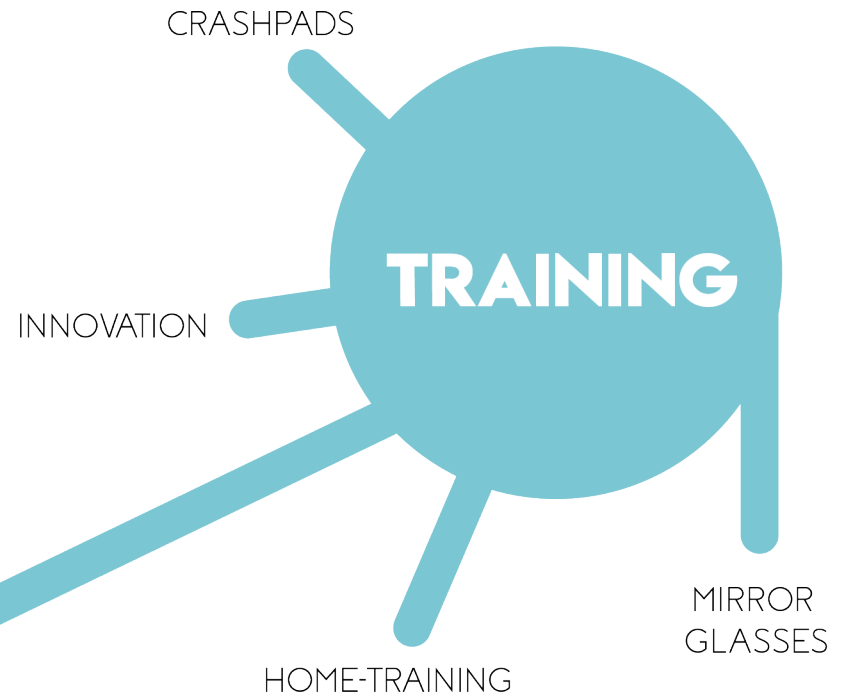

Then it appeared hometraining , what is nowadays a real movement. Social media and apps with training routine are more and more common everyday. Also during our market survey we couldn't find a well-built and well-thought hometraining tool, only just some most passionate climbers fix traditional grips to their walls. So seen that tendencies and the idea of transport yourself to a different place, because we that you collapse space, our group decided to continue focused on this idea.

The second concept that appears in mind was the economical. Money runs the world, but some prices are prohibitive. Especially when we talk about "hobbies" with technical equipment. While been in the climbing center we realised that the sole and the shoe itself worn out quickly, so the only changing the sole could help economically to save some money to users. After discuss the idea, it was not really tangible creating a shoes that has an attachable sole, because probably it could disattached at some point while climbing.

THERMO-FOOD

HELMET
W/ HEADLIGHT

COMBINING GEAR

SLEEPINGBAG
HAMMOCK

FIRST AID KIT

BRAID BELT

The third concept that came up was combining gear. Mountaineers usually spend a couple of days in their trip and that requires a lot of equipment to bring with them. All the ideas are based in reduce the space things occupy or to have extra security items. Also this ideas covered what we understand as a physical collapsible space and gave response to the mountaineers request in previous process too.

Actually, sleepingbag hammock was also one of the favourite ideas to go further with. But ourselves believe that mountaineers would not feel confidence about a product that needs high qualiflicated technical climbing knowledge and is developed by a group without any previous expirience in

The last concept that was thought of was social life. For climbers, but in particular for mountaineers socialise is a must. It is one of the things that they look forward by going up in the mountain, spend an amazing time with friends. Although, finding the right person to climb with or finding new persons is difficult. It is about a feeling of trusting, but also about of being the same skilled as your patner to help eachother in front of an unexpected event.

That is why the thought of making an app to connect people seemed nice to us.

Try to offer an easier way to find the perfect match for climbing. Also thinking not only as a connecting app, but having some more features like geographical maps or the possibility of recommend routes to the community.

This concept was dismissed because our team want to develop a real and

GEOGRAPHICAL MAP

SOCIAL

MEETING PLACE

"TINDER"

ITERATION PHASE

PERSONAL SURVEY TO CLIMBERS

After moving forward with our choice of develop a hometraining tool, coming back to mountaneering community was like a common sense everyone has. We were looking not only for some feedback about the concept, but also what kind of shapes they appeal the most. It was pleasing to get a good response, so we could know we were in a good track to follow and also get some new ideas about how the object should be.



Fig 15. Organic shapes we showed to our survey respondents

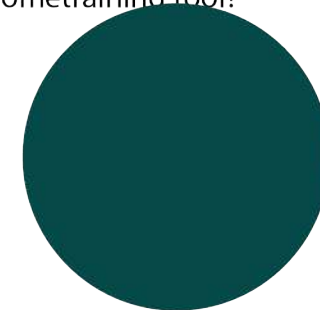

Fig 16. Geometrical shapes we showed to our survey respondents

What we learned from with the questionnaire is that actually climbers also think grips are bad looking somehow. They do not really have a preference between organic or geometrical shape, but they feel more identified with organical world. That it is probably because they are always surrounded by the natural world and that involve organical shapes.



Are you more into the organic pictures or geometrical ones?
Do you think is a good idea to created a new hometraining tool?



What do you feel represent more the climbing community: organic shapes or geometrical??

Fig 17 . Illustration of results obtained in survey by Celia Manzano

ITERATION PHASE

ATTACHABLE PIECE TO THE WALL CONCEPT

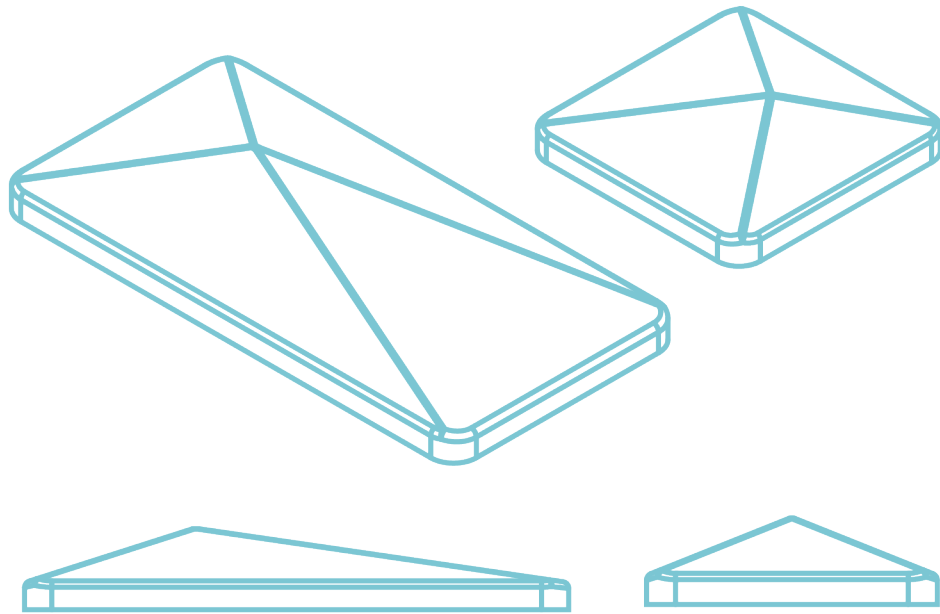

Fig 18. First idea about the attachable piece. Illustration by Stian Luneborg

RECTANGULAR AND HEXAGON IDEA

These shapes came to life by going in the opposite direction of which the traditional grips are designed. Transforming organic into geometric shapes.

The choice of rectangular and hexagon shapes in this idea where to make some rules for the user to follow. To give the them freedom to choose and at the same time make it easier to compose than an art piece made on a blank page, by having the grid and lines that these shapes naturally make.

The angles on the shapes is made to implement a variation of grips.

INTRODUCTION

This idea is based on that the mountaineers expressed that they not want to be associated with boulderers or nessesarily with other climbers. That made us look into redesign of the traditional grips and how it also could be hidden when not in use, to make a collapsable space.

Based on vistits at their arena and usual enviroment, we were led to look into art and then implementing the grips. Taken in consideration that the cultural group has shown to be into DIY, the idea is made so that the user can make choices and arrange for themselves.

While doing this the feeling of building and using their identity will be apparent. By using the wall it would not take unnessesarily space from the room and rather add a dimation.

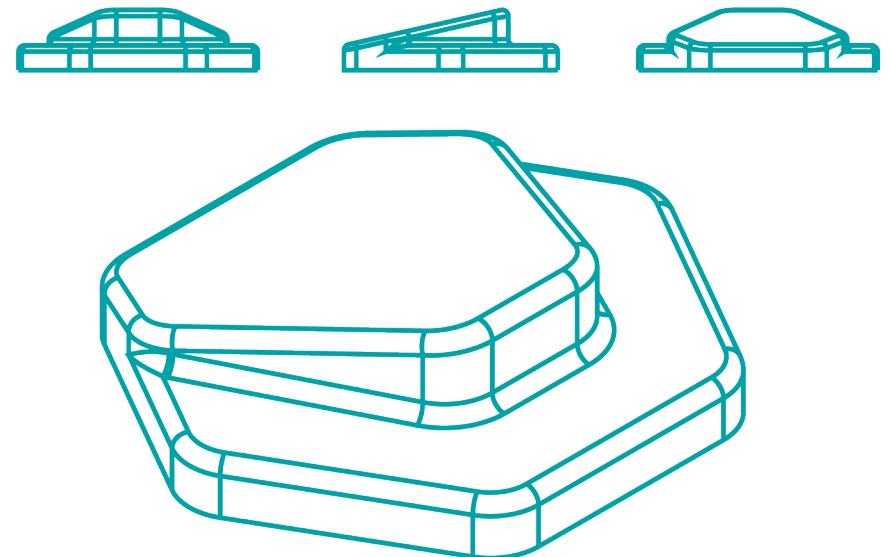

Fig 19. Hexagonal shape for attachable piece.. Illustration by Stian Luneborg

ITERATION PHASE

ATTACHABLE PIECE TO THE WALL CONCEPT

CIRCLE IDEA

This idea is also based on how the user will manage to see a pattern and follow this while arranging them on the wall, and still have the freedom to set up the pieces as preferred.

This is a step back to the organic shape to once again ask the target group how they feel about the different shapes. When deciding this circular shape we found it to have a rich amount of variations of ergonomic grips.

With this piece, we started to feel that we were into a real concept and that this idea could go further with good results.

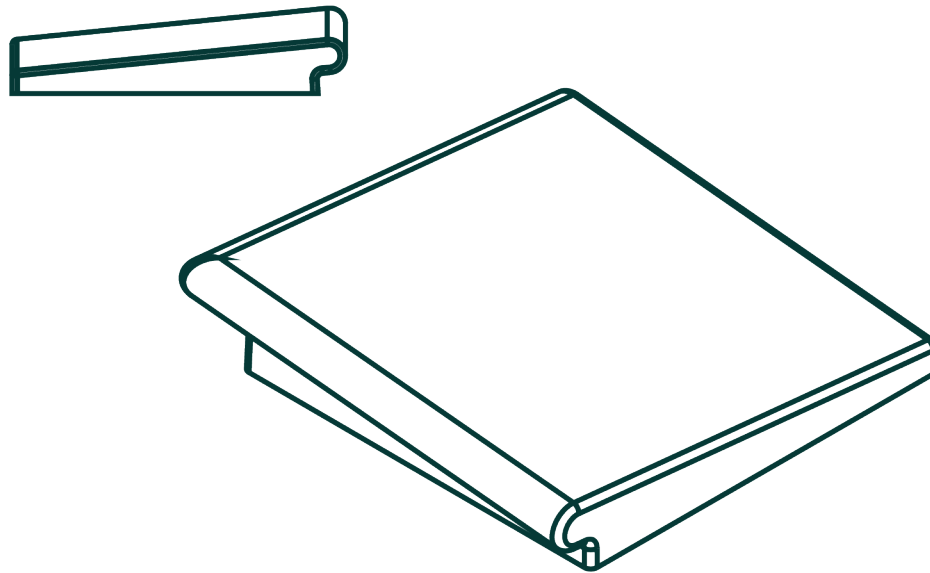

Fig 21. Tilted square shape for attachable piece. Illustration by Stian Luneborg

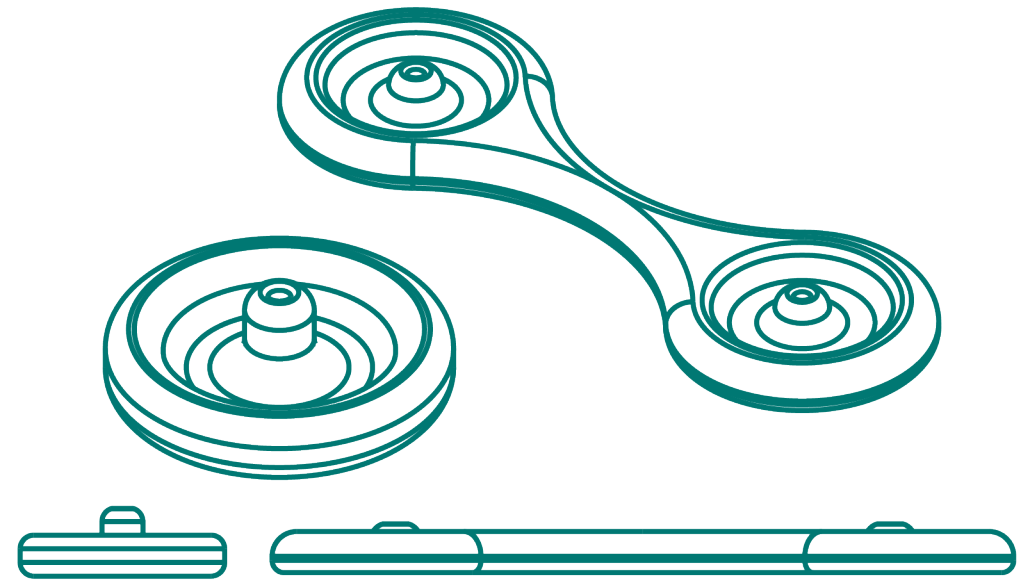

Fig 20. Circular shape for attachable piece. Illustration by Stian Luneborg

SQUARED IDEA

Our latest but not potential idea appeared while we were trying to develop different seasonal packs that differed from the idea above. And thinking in terms of collection.

In the middle of organic and geometric it seemed to have a lot of opportunities towards ergonomic grips and the freedom within a set of rules. To give the shapes as an art piece more dimensions the work with angles made a variation of playful shadows, while in the same time cover the grips needed to fulfill basic climbing workout.

ITERATION PHASE

CLIMBING FURNITURE CONCEPT

This concept is about implementing possibilities to work out by climbing in your everyday life. Here is the different ideas of a fixed closet with shelves and a modular shelf where you can decide for yourself which height you want.

In both of the ideas the possibility to climb is apparent to the user, but hidden to those without knowledge about it. The idea of not using additional space in your home by changing already existing furniture makes the product fit those that also live in apartments, and do not necessarily have a lot of free space.

This thought came short when thinking of the market within mountaineers. As it is not that big of a cultural group within Norway, missing some of the possibility for them to be in charge of mounting and arranging and therefore not have that strong of a connection or identify with the product, it came to us deciding to choose another concept.

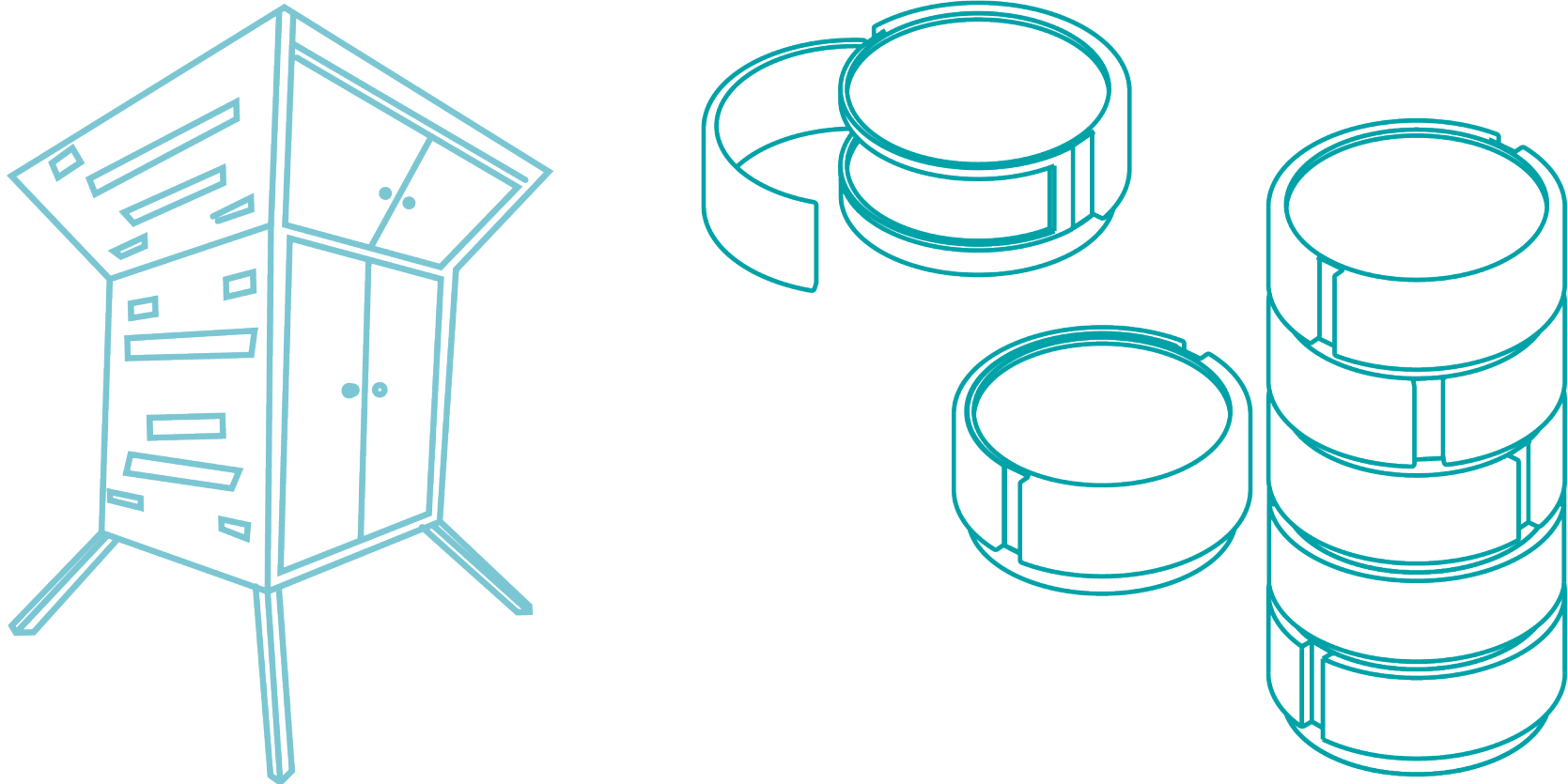

Fig 23. Sketches about the climbing furniture concept. In the right side the cupboard idea , in the left side the shelf idea. Illustration by Stian Luneborg and Oddmund Lilletofte.

ITERATION PHASE

APARTMENT CONCEPT

While having a workshop within the course, the idea of changing your whole living space into a simulation of the emotions you have while hiking came up.

This is where your whole roof is a rotateble climbingwall, where you open up to get natural light in and get the possibility to climb up to get fresh air and to get an overview. The idea is about simulating what the climber usually values and desire. To erase the distance between the climber and the climbing centre.

When this is integrated the user will be more in contact with their lifestyle in their everyday life and at the same time have the possibility to close of the world around to relax by themself.

Even though this idea is a solution to many of the keypoints we got in the feedback, we had to prioritize. As this being such a big concept, including much of architectural and engineering solutions, we chose to cut this short and rather focus on the other concept to manage to make a well worked thought product.

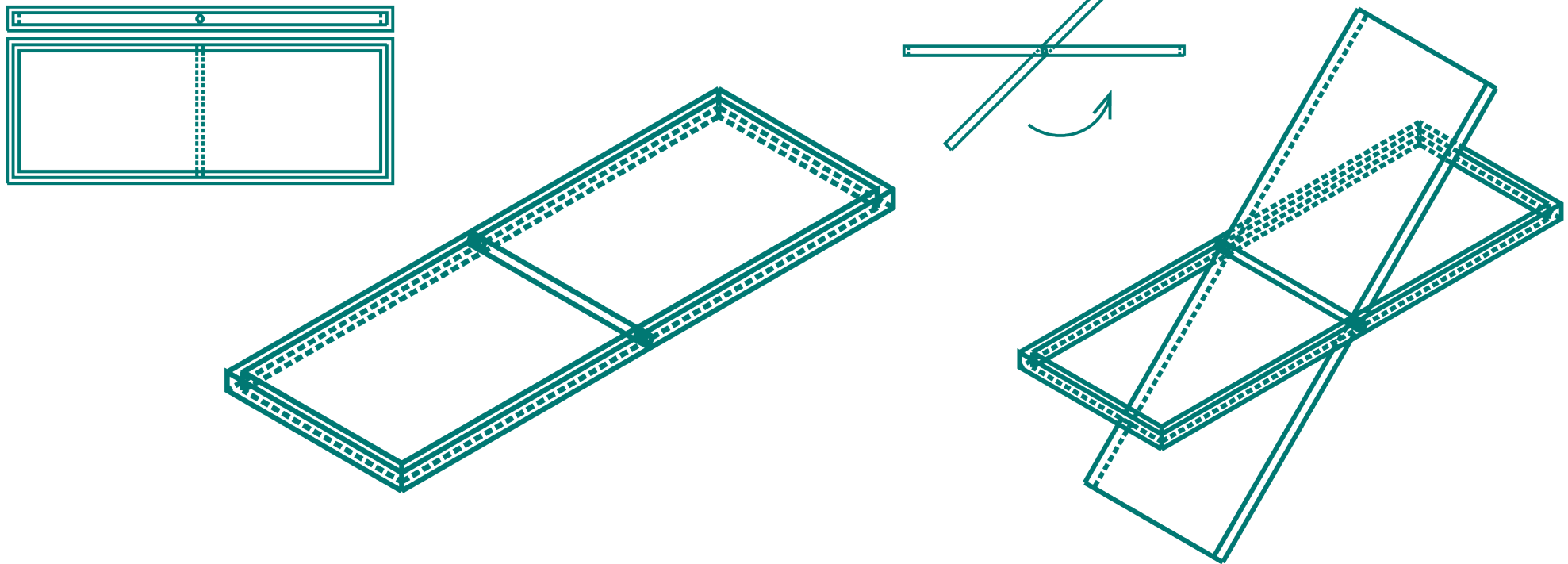

Fig 23. Sketches about the apartment concept. Detailed rooftop is showed. Illustration by Stian Luneborg

ITERATION PHASE

FEEDBACK WITH CLIMBERS

Going forth with the ideas and showing them to our contact persons within the group, we received feedback that influence how our further decisions were made.

When they had come with their opinions two out of three concepts have been voted down, the concept that was left was attachable wall climbing piece. Then, while showing the different shapes and explaining their pros and cons, feedback was given on whether they seemed to fit the group and their purpose.

This resulted in arguments for further work with the middle way between organic and geometric

As said by the mountaineers, too organic shapes will stick too much out and be in a too big contrast to the already existing shapes on furniture and interior.

To make it go along with what was described as a regular household environment and still have both the artistic and functional aspects. As a conclusion, decision was made to go on with the square shape.

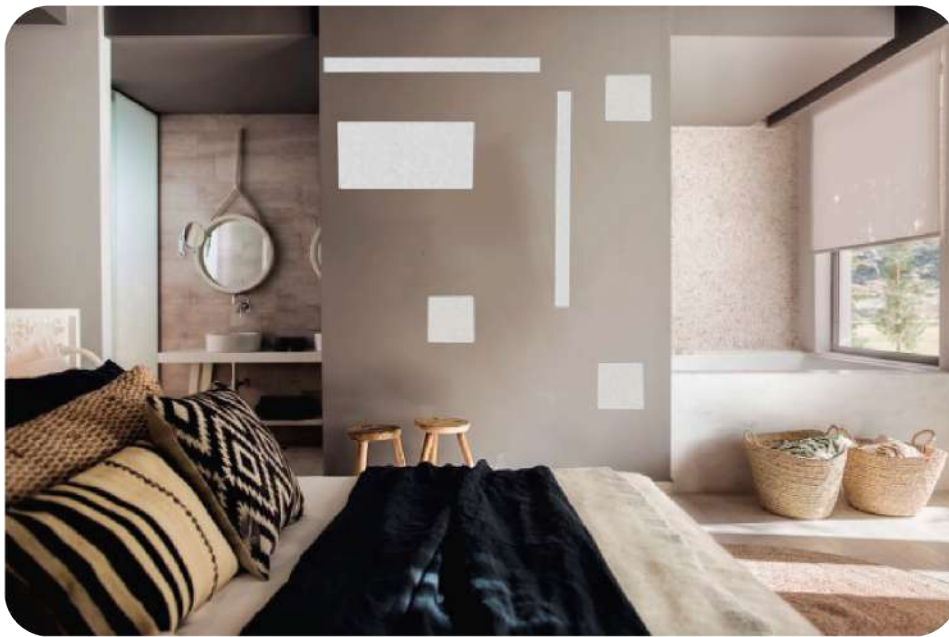

Fig 23. Images to show the concepts we were working at. Editing by Celia Manzano

ITERATION PHASE

RAPID PROTOTYPING

The first generation of mock-ups was about finding shapes and measurements in paper and cardboard.

These were built from exploring the possibilities within arranging in 2D for an artistic look and function. Further it was focused on making it in 3D to get a rather real impression of what the object would be in space and how the wall was affected by it.

This gave important information that guided the process from six square and rectangular pieces to one. This final shape was possible to vary in dimensions and arrange all the function surfaces. This determinative changes, helped by Einar, give us the final design.



Fig 24. 3D first generation prototypes . Photograph by Oddmund Lilletofte



Fig 25. 3D prototype. Photograph by Oddmund Lilletofte

IMPLEMENTATION PHASE

FINAL PRODUCT. SHAPE & MATERIAL DECISION

In the image below you can appreciate how we turn into a reality the concept of an attachable piece to the wall. The main purpose of this is redesign traditional grips with an artistic touch.

The decision of use in our product square shape gives strength, but at the same time inclination on the top makes it more artistic. Also the rounded projection evokes the traditional grips so it catch the climbers attention.

The material choice we made is based on the touch of stone mixed with a nowadays material. That's why we chose concrete, to also enhance a proper environment while our product is in use.



Fig 26. Render of our final product. Render by Celia Manzano

IMPLEMENTATION PHASE

DIFFERENT SIZES

All the different sizes are based on the same criterium: having the same height in each corner, as a consequence it is created different inclinations of the top, giving different difficulty to the pieces. So starting in the bottom and right corner (the lowest one) and following clockwise the measurement are: 2, 4, 8, 4 cm. The smallest one is a quarter of the biggest one and the medium one is in between, that creates a pattern which helps to create a composition.



BIG PIECE
23x23



SMALL PIECE
11.25x11.25



MEDIUM PIECE
15.5x15.5

Fig 27. Different sizes and measurements of the grip. Photograph by Stian Luneberg

IMPLEMENTATION PHASE

WHY OUR PRODUCT IS RELATED WITH ART?

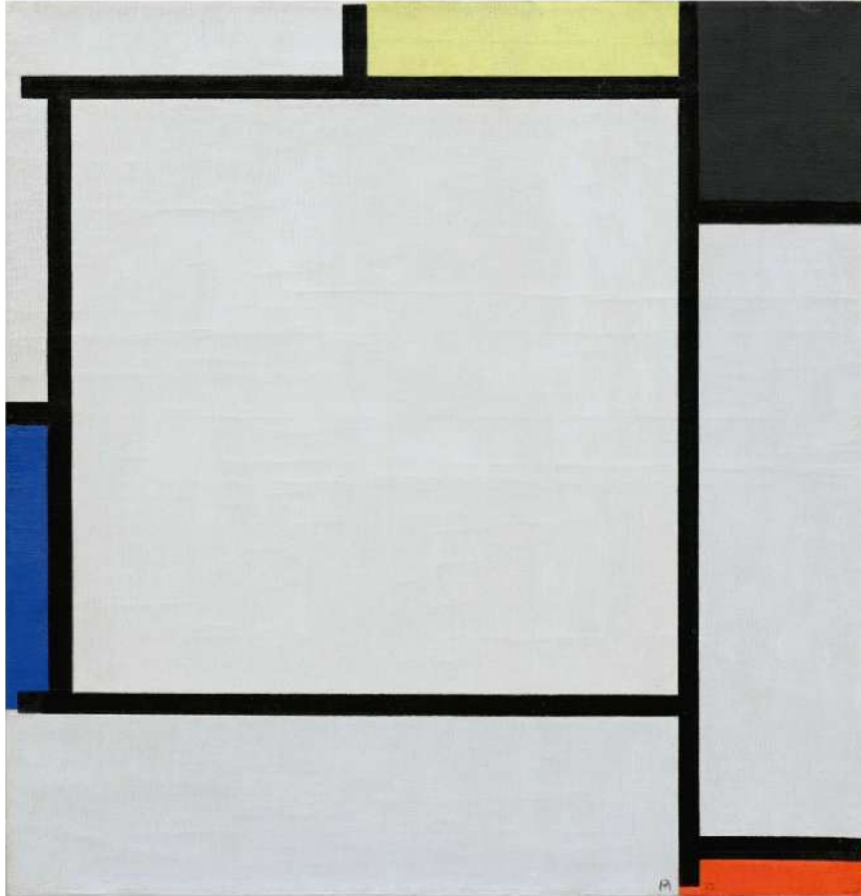

Fig 28. Neoplasticism piece by Piet Mondrian. Retrieved from: <http://www.piet-mondrian.org/ta>

It was a basic that our product accomplish the collapsible space concept.

With our final piece developed it is easy to see, how art is involved in our concept of grip. The collapsible space comes by creating a piece that it is art but it is not at the same time, that means that time and space is collapse at the same time. Also with the product mountaineers can disconnect from daily live and focused on their dreams and that is also a bit of emotinal collapsible space.

Continuing with art, it is seen that the square shape is not only what we found the best for improve the experience of training, but also it reminds to some avant-garde movements like neoplasticism, constructivism and suprematism. In this vanguards it is shown how a geometrical shape can express by themself feelings and actions, turn in into art.

IMPLEMENTATION PHASE

WHY THE PRODUCT IS A GOOD TRAINING SYSTEM?

To get the right amount of work out the mountaineers need and to train the right parts of the body a set of basic grips is needed. With the different angles and cuts into the product, its possible to work out both different finger grips and also train several of the big muscle groups.

Although this product contains a lot of different possibilities within grips and techniques such as: palming, undercling, gastones and side-pulls, our focus is on the basic grips. Because you will just with the basic grips you will cover most of the nessesary work out.

A grip that does not count that much on your strenght or grip technique, but rather depends on body control. While using this grip, its more about body control and how to make your force go as perpendicular to the gripping surface as possible.

SLOPER



A grip where you train the tendons in fingers and forarms, by just holding on with you fingertip

CRIMP



This grip is focused on strenghten your forearms and training grip technique.

PINCH

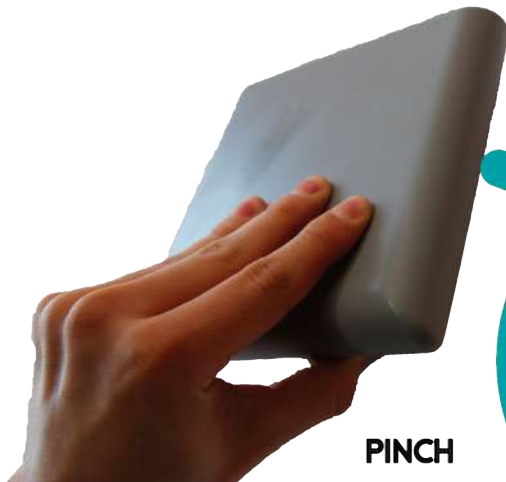

As this is an grip where not much strenght in tendons is needed, your focus can be on training the big muscle

JUG



Fig 29. Photos showing the different grips our object has. Photographs by Stian Luneberg

IMPLEMENTATION PHASE

MOUNTING SYSTEM

This part is essential to the safety and function. By mounting this to the wall with what screws fits the wall, in the arrangement that the user prefer, there is alot of possibilities. When this is mounted the user is able to rotate the product in every direction, and it will lock itself in the right place. By doing this both the grips and visual apparence changes. These mounting pieces is standard size, that makes them fit every of the objects and giving everyone of them the same amount of oppertunities to be arranged as wished.

About safety, this feature communicates being safe by being made of steel that goes within the concrete object (more technical information is given in appedix 3). This is fastened to the wall with four screws, when this is done and the way of placing the object is decided, its just two more screws needed to fasten everything. These two screws is what keeps the object fixed to the mounting part. Just by removing these, the user is once again free to change direction of object, and then fasten again.

By placing this on the back and into the object, the shape will not loose its estetics. The two screws to fix the two objects is also hidden behind the cut into the object, of the same purpose

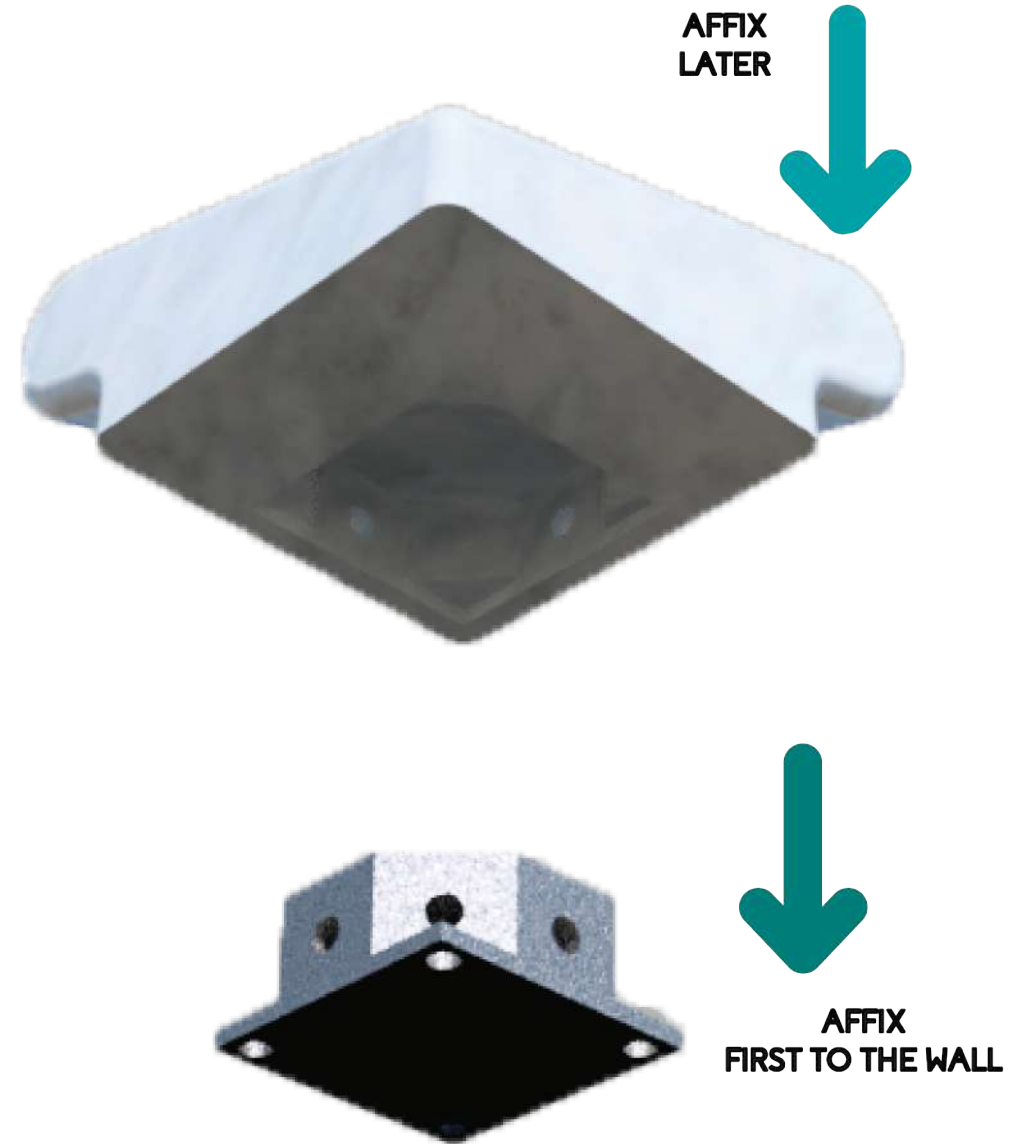
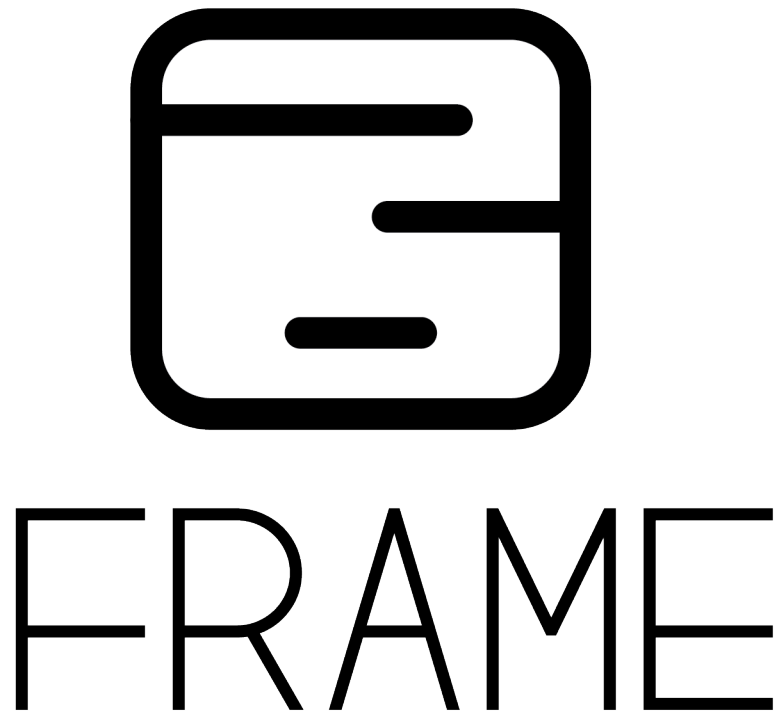

Fig 30. Render of our mounting system. Render by Stian Luneberg

IMPLEMENTATION PHASE

BRANDING & NAMING



Making a good eye-catching branding and with a easy memorable name helps a lot with the marketing of your product. So, after a bunch of brainstormings we finished with FRAME.

Our logo is an abstraction of the object we created. The square with rounded corners symbolise the topview of the product, but also the lines in the middle represent the three different sizes that exist for the object and at the same time visualize climbing by having a connection to a ladder.

The brand name comes from having the invisible grid that comes with the square shapes, so that you will imagine a framework around your assembly of the objects. It also refferd to the «frame» that is common placed for emphasise and art piece.

Fig 31. Logotype of our product. Illustration by Celia Manzano

IMPLEMENTATION PHASE

PACKAGING

The packaging is developed to be space efficient and also protect the object within. The size of the packaging is 40x30x15cm. In each standard pack you will get two pieces of every size with a mounting part for each of them. There will be five different packages to choose from that varies in color to follow different seasons.

If more pieces is wanted, this is possible to buy separately with the color of the users choice.

There will also be some standard screws to mount the parts to the wall, but special screws to mount to plaster walls and brickwalls the user needs to buy it separately. The screws needed to fix the object to the mounting part follows in the packaging.

The packaging is made of recyclable cardboard, to represent the nature-friendly thinking of the mountaineers. Also in mind that packaging rarely is being saved by the customer. For protecting the elements to crashed or scratches during transportation is going to be used packaging foam.

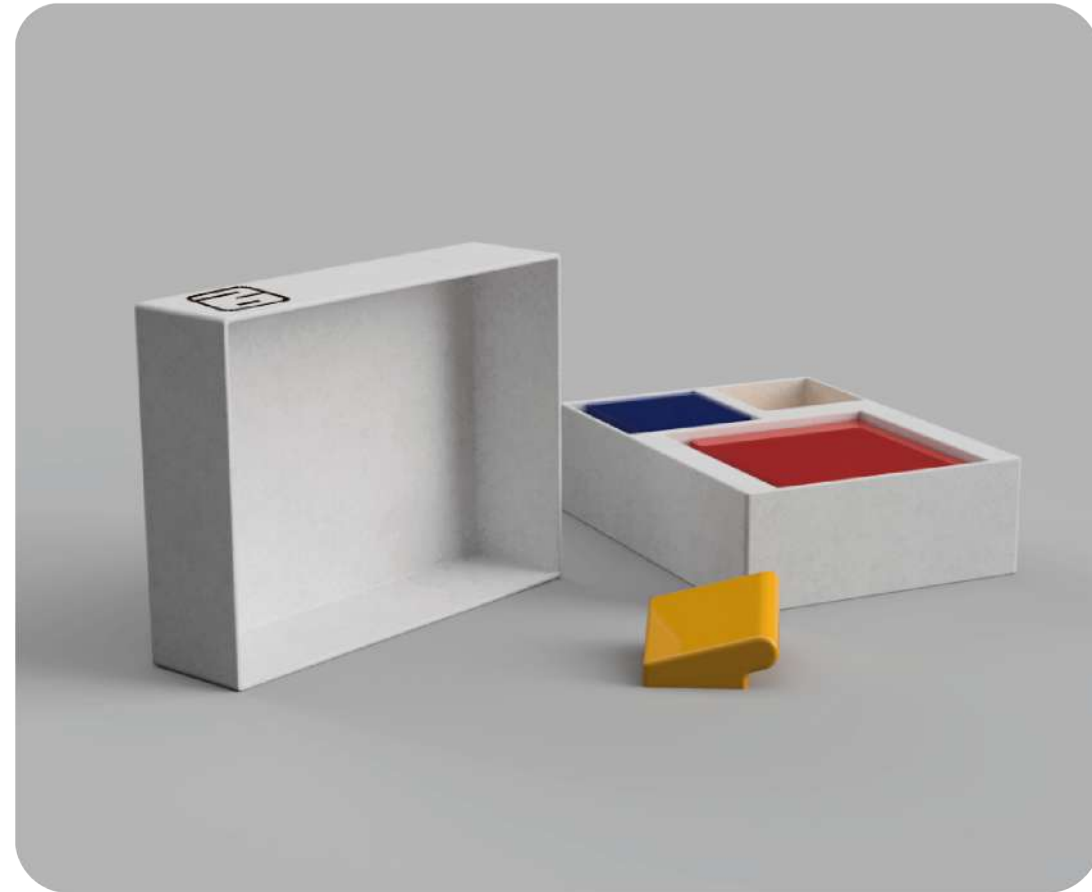

Fig 32. Render of how the packaging look. Render by Stian Luneberg

RESULTS OF DESIGN PROCESS

As a result of all the it is presented the colour palette. The potencial users would have the opportunity to choose the colours they like and that are capable of create a cool ambient in their homes. Also the seasonal package created by the brand would only be made up of the same spectrum colour and would change across the time.

In the following pages it can be appreciate the final result of the product and how it would look in real cases.

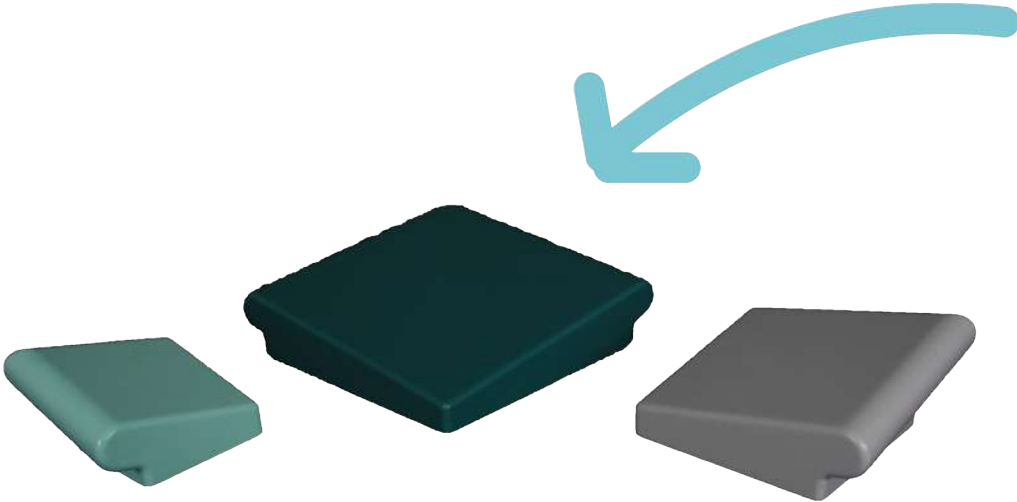

Fig 33. Illustration of the colour palette. Illustrated by Stian Luneberg



Fig 35. Render of the product in use. Edited by Celia Manzano



Fig 34. Render of the product in use. Edited by Celia Manzano



Fig 36. Render of the product in use. Edited by Celia Manzano

MATERIAL

The material choice of concrete is based on simulating the feeling of rock that is very familiar to mountaineers. When concrete is used it communicates safety by being known for its hard structure.

ROUND EDGES

The round edges invites to interaction where the lightly rough texture triggers the tactile senses.

SHAPE

The three different squares has the same depth, but the angle on the top differs because of the different sizes. This shows to the feeling of going upwards, that is crucial for the mountaineers.

COLOUR

The colorpallet chosen for the product relates to colors you will find in nature and the different seasons. Since being outdoors is a critical part of the mountaineers life, this is an oppertunity get some of the feeling home.

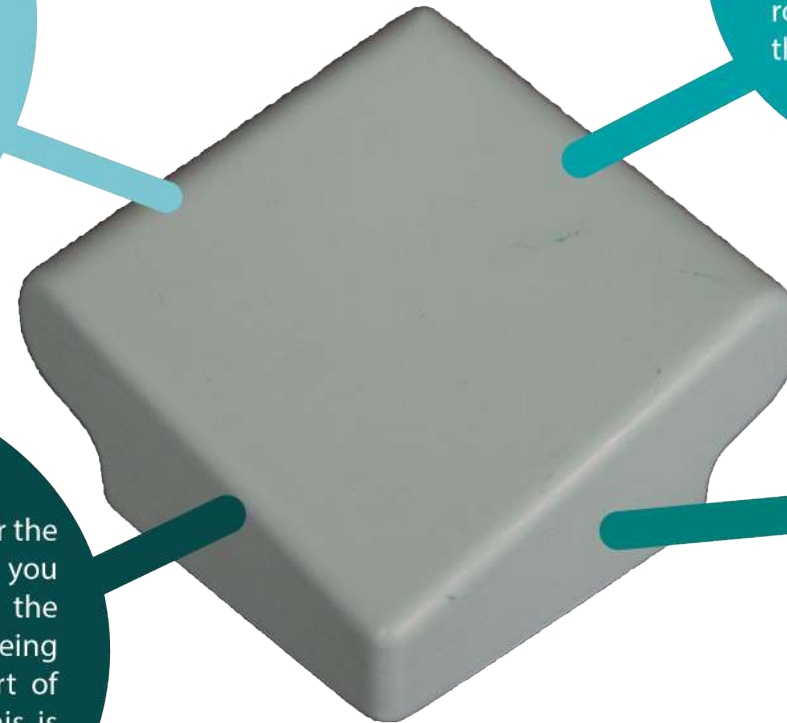

Fig 37. Photograph of our final prototype. Photograph by Stian Luneberg

COMMUNICATION

EXHIBITION DESIGN

Within the rules decided by the class, our group has chosen to have one table and one wall.

Since our product is in the area of interior and art, it gives a good impression to have it hanging on a wall with a suggestion of how to set up and create a nice composition. By having the product on display this way, the viewers can interact with the product and get the feeling of a connection with it. Beside the wall, on a table, we will have a catalog with information about the project, the cultural group, details about the product and different variations of set up and colors.

The measurements would be 60x60x90 for the small one and 60x40x180.

The plates that are going to be attached would have a thickness of 3/4 cm and are going to be made out of MDF painted in white for the wall and black for the table. The elegance and the capacity of empower our product is the foundation for the choice of colour.



Fig 38. Render of how the exhibition would look. Render by Stian Luneberg

COMMUNICATION

EXHIBITION DESIGN

The poster has few elements to get focus to the cultural group and product. The eyecatcher is the mountaineer on the top, that relates directly to their hobby. Then there's the product that is shown on a surface that fades towards the mountaineer, this is to visualize the connection and short distance from our product to the goal. The logo is placed to substantiate this connection, by having the association to a ladder, this also represents the climbing between the product and the goal. The brand name is placed to be seen, and serves the purpose of breaking up the line it mirrors.

w



Fig 39 Poster. Illustration by Stian Luneberg

COMMUNICATION

WEB DESIGN

With focus on the mountaineers as the usergroup, the webpage has the same background. When being outside in nature has been in focus most of your life and the use of computer has been downprioritised, the patience to manage around on a computer to find what your looking for is often not strong.

To get to the point where the product is in focus, the website has an setup that makes it easy to get around. Then the user wont get the feeling of getting lost, but rather be in control over where to go next. The web page is made with contrasts in mind. When using the dark background to get the focus both on the product and the world around. While using the computer manouvering around the Internet and discovering this website, the darkened feeling relates to the contrast to be outside in the open.

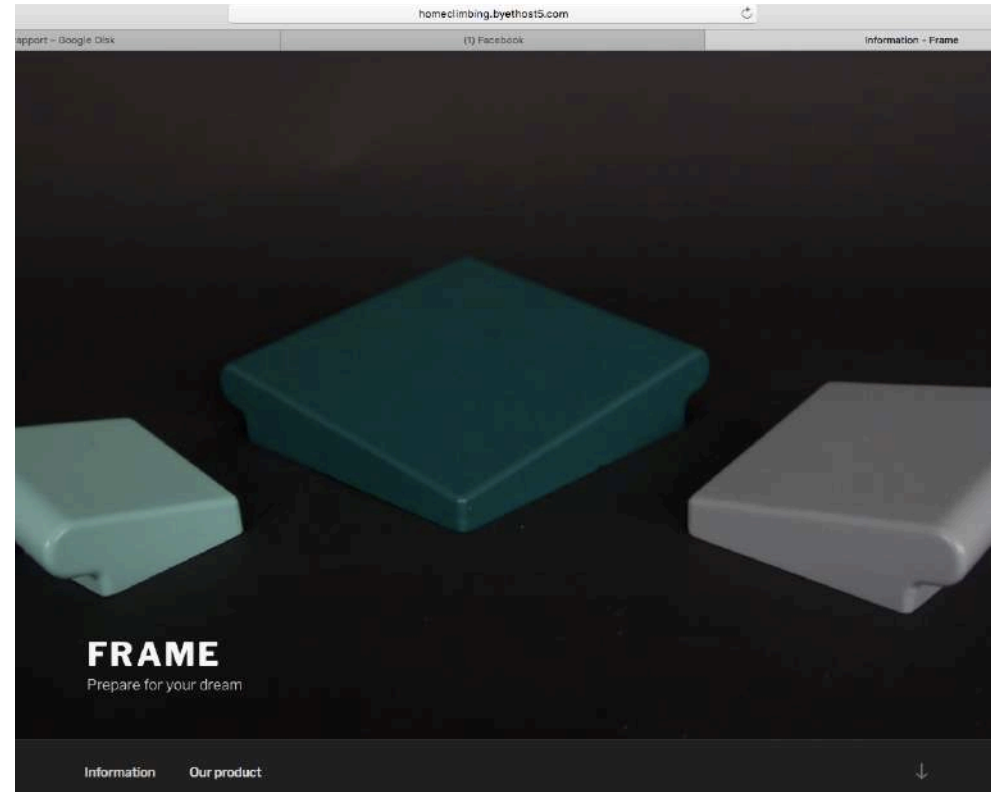

Fig 40 webdesigne. screenshot by oddmund

COMMUNICATION

PRESENTATION

PREPERING

When starting to make the presentation, we were looking back at our earlier presentations we had on the milestone meetings. From this we had learned that its important to have a linear presentation, that builds up the expectations until the point where you release the solution. We learned that is important to get the audience to keep up with the information. To start the presentation we made a introduction of who the audience were supposed to be, and wrote down a script with the most important keypoints of a mountaineers life. We also looked back at our interviews with the cultural group to further analyze their language, which we implemented in our presentation. This consisted of big words as «dream», «amazing» and «fantastic», to appeal to their emotions towards mountaineering. We were also avoiding text and mostly using full screen pictures to simulate the feeling you would get out in the nature, on a hiking and climbing trip.

Further we used photos of our product that showed how it could look in different homes.

FEEDBACK/ LEARNING OUTCOME

We were happy with our feedback, it felt like our presentation was met by the audience as intended. They gave us the impression of being convinced the product being a good solution. Although some of the comments were based on the linear set up, that we had been holding back some important information for to long, such as how to mount the product to the wall. The audience also mentioned that they would like more information about details, such as color choices and sizes. They also said it could be a good idea to show more variations of the product mounted in homes, and the product in use.

We got some constructive comments, and left the scene with a feeling of a well played presentation.



Fig 41 Some pictures from the illustration. Illustration by Celia Manzano

CONCLUSION

In the process of this semesters course, lengthy phases has overlapped eachother given a strong background with information and insight about the cultural group. This has brought with it knowledge of a group that before was foreign, that both confirmed and dismissed some of the thoughts about stereotypes we started with.

Every aspect of the course cultural group, communication and presentation has been covered with practise, theory, different methods and exercises.

Starting with a research phase going in the depth of the unknown, the way back up to a new chapter of ideation were filled with new thoughts and options to give back to the community. While floating in the river of new information, grabbing for branches to hold on to made the weak concepts and ideas break, and new stronger branches come apparent. By having a close connection to the community while the project was going, the feedback from them gave us possibilities to further develop the project to fit their needs and wishes.

As a part of the unsaid, the natrually strong individuals in this group communicated their instinctive sense of control. The product comes with an oppertunity for them to be in charge, take their own choices and strenghten their identity.

The importance of their life with outdoors activities and nature is brought into the design by taking in consideration sustainability, lifetime and several connections to the wildlife.

Along the way, the view of what a collapsable space could be were changed, and made the decision making go in another direction.

With this we wish that our product become a helpful personal tool for the users to reach their goal.



Fig 42 Final product photo. Photograph by Stian Luneberg

Image Reference

- Fig 1. Celia a Oddmund, Stian selfmap
- Fig 2. Arne Næss practicing climbing. Retrieved 11.04.18 from: <https://www.norsk-klating.no>
- Fig 3. Graphic of our previous design process. Illustration by Celia Manzano
- Fig 4. Indoor bouldring. Retrieved 11.04.18 from: <https://en.wikipedia.org/wiki/Bouldering>
- Fig 5. Trad climbing. Retrieved 11.04.18 from: https://readtiger.com/wkp/en/Traditional_climbing
- Fig 5. Trad climbing. Retrieved 11.04.18 from: https://readtiger.com/wkp/en/Traditional_climbing
- Fig 7. Sport climbing. Retrieved 11.04.18 from: <http://www.fanrto.com/topics/rock-climbing-sport.html>
- Fig 8. Mountaineering. Retrieved 11.04.18 from: <https://patfalvey.com/product/island-peak-everest-base-camp/>
- Fig 9. Graphic of our stereotype charecter Illustration by Celia Manzano
- Fig 10. Photographs from Sportslageret. Photos by Oddmund Lilletofte
- Fig 11. Oddmund, Stian and Celia practising bouldering. Photos by Oddmund Lilletofte and Celia Manzano Mnzano
- Fig 12. Illustration showing the basic data we collected from individuals. Illustrations by Celia Manzano
- Fig 13. Illustration showing the mountaineering community. Illustration by Stian Luneberg K2. Retrieved 11.04.18 from: https://upload.wikimedia.org/wikipedia/commons/6/68/K2_-_top_of_K2.jpg
- Adventurer. Retrieved 11.04.18 from: <https://wallpapers.gg/hiker-on-top-of-a-mountain/> Climbing camp. Retrieved 11.04.18 from: <https://www.achensee.com/en/event-dates/summer-events/training-camps/achen-see-climbing-camp/> Indoor bouldering. Retrieved 11.04.18 from: http://boulderingonline.pl/index.php/bouldering-site-map/467-super-fun-training-problem-at-the-house-from-a-few-weeks-ago?epik=0mRL4E_IWXx-Fw
- Fig 15. Organic shapes we showed to our survey respondents
- Fig 16. Geometrical shapes we showed to our survey respondents
- Fig 17. Illustration of results obtained in survey by Celia Manzano
- Fig 18. First idea about the attachable piece. Illustration by Stian Luneborg
- Fig 19. Hexagonal shape for attachable piece.. Illustration by Stian Luneborg
- Fig 21. Tilted square shape for attachable piece. Illustration by Stian Luneborg
- Fig 20. Circular shape for attachable piece. Illustration by Stian Luneborg
- Fig 23. Sketches about the climbing furniture concept. In the right side the cupboard idea , in the left side the shelf idea. Illustration by Stian Luneborg and Oddmund Lilletofte.
- Fig 23. Sketches about the apartment concept. Detailed rooftop is showed. Illustration by Stian Luneborg
- Fig 23. Images to show the concepts we were working at. Editing by Celia Manzano Indoor bouldering. Retrieved 11.04.18 from: <http://casa-cook-rhodes-85103.rhodeshotelsweb.com/de/> outdoor bouldering. Retrieved from: <https://www.gessato.com/behind-design-vincent-van-duysen/>
- Fig 24. 3D first generation prototypes . Photograph by Oddmund Lilletofte
- Fig 25. 3D first generation prototypes . Photograph by Oddmund Lilletofte
- Fig 26. Render of our final product. Render by Celia Manzano
- Fig 27. Different sizes and mesurements of the grip. Photograph by Stian Luneberg
- Fig 28. Neoplasticism piece by Piet Mondrian. Retrieved from: <http://www.piet-mondrian.org/ta>
- Fig 29. Photos showing the different grips our object has. Photographs by Stian Luneberg
- Fig 30. Render of our mounting system. Render by Stian Luneberg
- Fig 31. Logotype of our product. Illustration by Celia Manzano
- Fig 32. Render of how the packaging look. Render by Stian Luneberg
- Fig 33. Illustration of the colour palette. Illustrated by Stian Luneberg
- Fig 34. Render of the product in use. Edited by Celia Manzano
- Fig 35. Render of the product in use. Edited by Celia Manzano
- Fig 36. Render of the product in use. Edited by Celia Manzano
- Fig 37. Photograph of our final prototype. Photograph by Stian Luneberg
- Fig 38. Render of how the exhibition would look. Render by Stian Luneberg
- Fig 39. Poster. Illustration by Stian Luneberg
- Fig 40. webdesigne. screenshot by oddmund
- Fig 41. Some pictures from the illustration. Illustration by Celia Manzano

APENDIX

Personas



CHRIS

AGE 34

GENDER MALE

HOW MUCH HAVE YOU BEEN CLIMBING?

12

WHAT TYPE OF CLIMBING DO YOU PRACTISE?

INDOORS AND OUTDOORS

HOW ACTIVE ARE YOU?

NO ACTIVE ————— ACTIVE

WHAT IS YOUR OBJECTIVE BY CLIMBING?

HAVE A LIFESTYLE

PERSONAL STUFF



ALL LINK
TO CLIMBING



EMIL

AGE 34

GENDER MALE

HOW MUCH HAVE YOU BEEN CLIMBING?

6

WHAT TYPE OF CLIMBING DO YOU PRACTISE?

INDOORS AND 2-3 TIMES PER YEAR OUTDOORS

HOW ACTIVE ARE YOU?

NO ACTIVE ————— ACTIVE

WHAT IS YOUR OBJECTIVE BY CLIMBING?

SOCIALIZE

PERSONAL STUFF



WORK AS A CONSULTANT
IN KOLSÅS KLATTERCENTER

Personas



MIRIAM

AGE 28

GENDER FEMALE

HOW MUCH HAVE YOU BEEN CLIMBING?



WHAT TYPE OF CLIMBING DO YOU PRACTISE?

MOSTLY OUTDOORS

HOW ACTIVE ARE YOU?



WHAT IS YOUR OBJECTIVE BY CLIMBING?

TRAVEL, MEET NEW PEOPLE

PERSONAL STUFF



TRENDY
CARES ABOUT FASHION



ANNA

AGE 46

GENDER FEMALE

HOW MUCH HAVE YOU BEEN CLIMBING?



WHAT TYPE OF CLIMBING DO YOU PRACTISE?

INDOOR

HOW ACTIVE ARE YOU?



WHAT IS YOUR OBJECTIVE BY CLIMBING?

CALM DOWN HER ANXIETY

PERSONAL STUFF



EXPENSIVE HOBBY

Meeting with Eystein at Pilestredet 32 Thursday 8. february

Big difference between mountaineers where enjoying the trip is in focus and sports climbers where the goal is to be fastest and always push yourselves "tinder", an arena to match with climbing partners, social skills, interests, (work together with ut.no or DNT?) functional app to find climbing spots important with everything around climbing, traveling, social etc mainly mountaineer and ice climber. on trips, the most important part is to get everybody both up and down. travels to climb, like long trips. has been on a 7000 meter mountain and the southpole and much more remember to look for climbers on their freetime, "everybody" uses the same clothing and climbing/jogging shoes. but thats mostly because of interest, no one really talks about it. its just a unwritten norm. works as a climbing instructor within rope climbing and ice climbing Facebook group: Isklatring rjukantinn expensive hobby, when your ice climbing you often walk around with gear worth of 30 K. many of the small parts costs like 1 K each. (Hes a bit reserved, doesnt talk that much without being asked, remindes me of Jakob.)

Meeting with Jakob Monday 5. february

gear freaks - mostly newbies the experienced has a more thought thru relationship to gear, want lightweight and multifunctional gear, to save weight on longer trips all around climber sense of achievement - mountaintops and overview ometimes on the way down from a mountain, carabiners and nuts needs to be left behind (hes a bit reserved, doesnt speak to much) Chamoni - climbing site with everything in France. other europeans have another approach to climbing, quickly up and down, while norwegians take it in their own speed and bring packed lunch check out: hexagon nut climbing level now: max 6. as young: 8-climbing as a lifestyle when he was younger the more dangerous and technical, the better needs a helmet you can put headlight on stretcher to the norwegian mountain rescue, small, stiff, lightweight, needs to fit a helicopter contact Åk fjellredning

TRAINING

INNOVATION

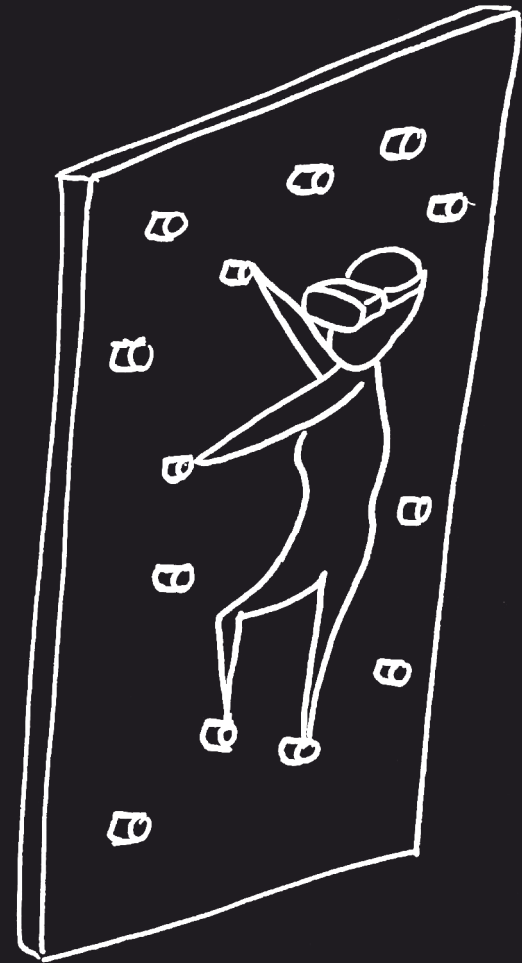
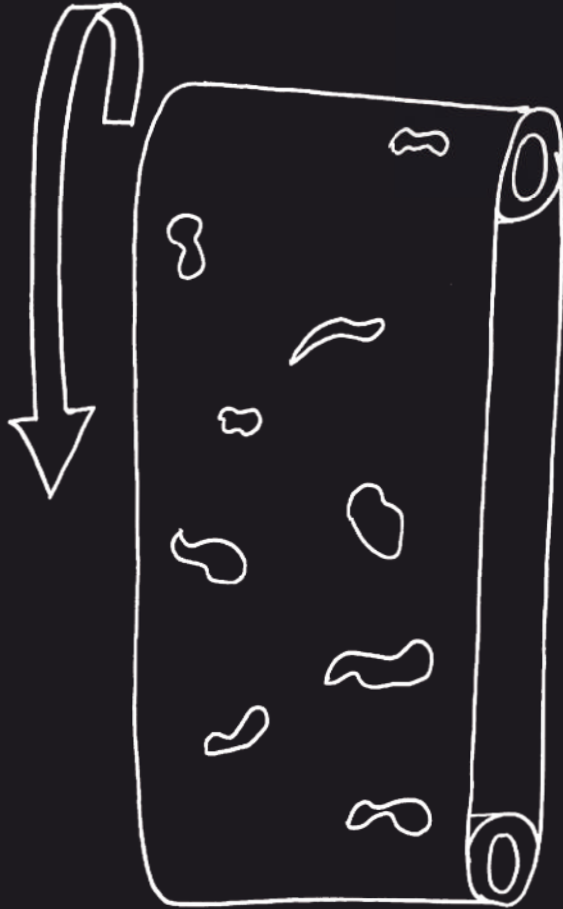

TRAINING

GLASSES WITH MIRROR

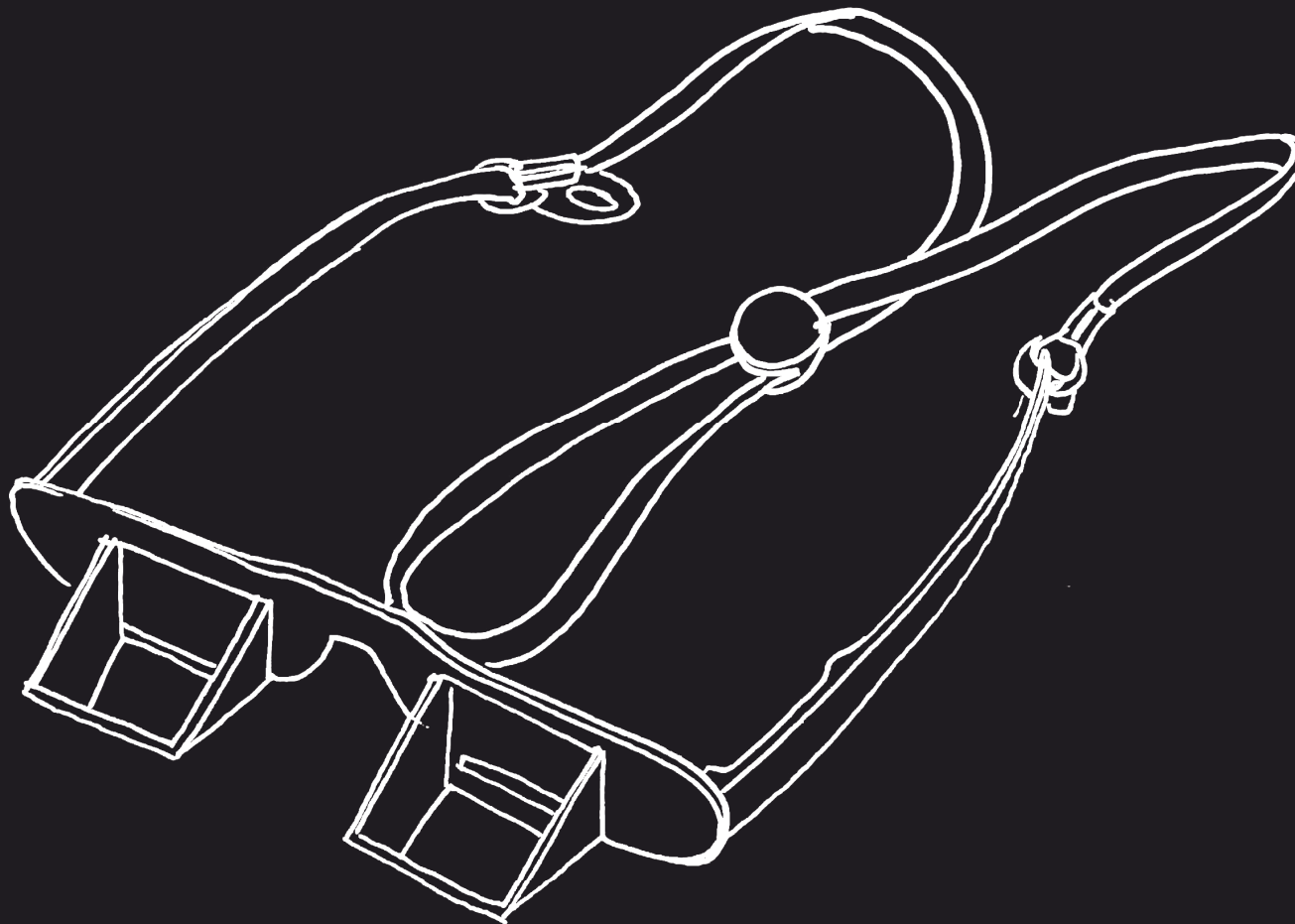

COMBINING GEAR

PADDING GEAR

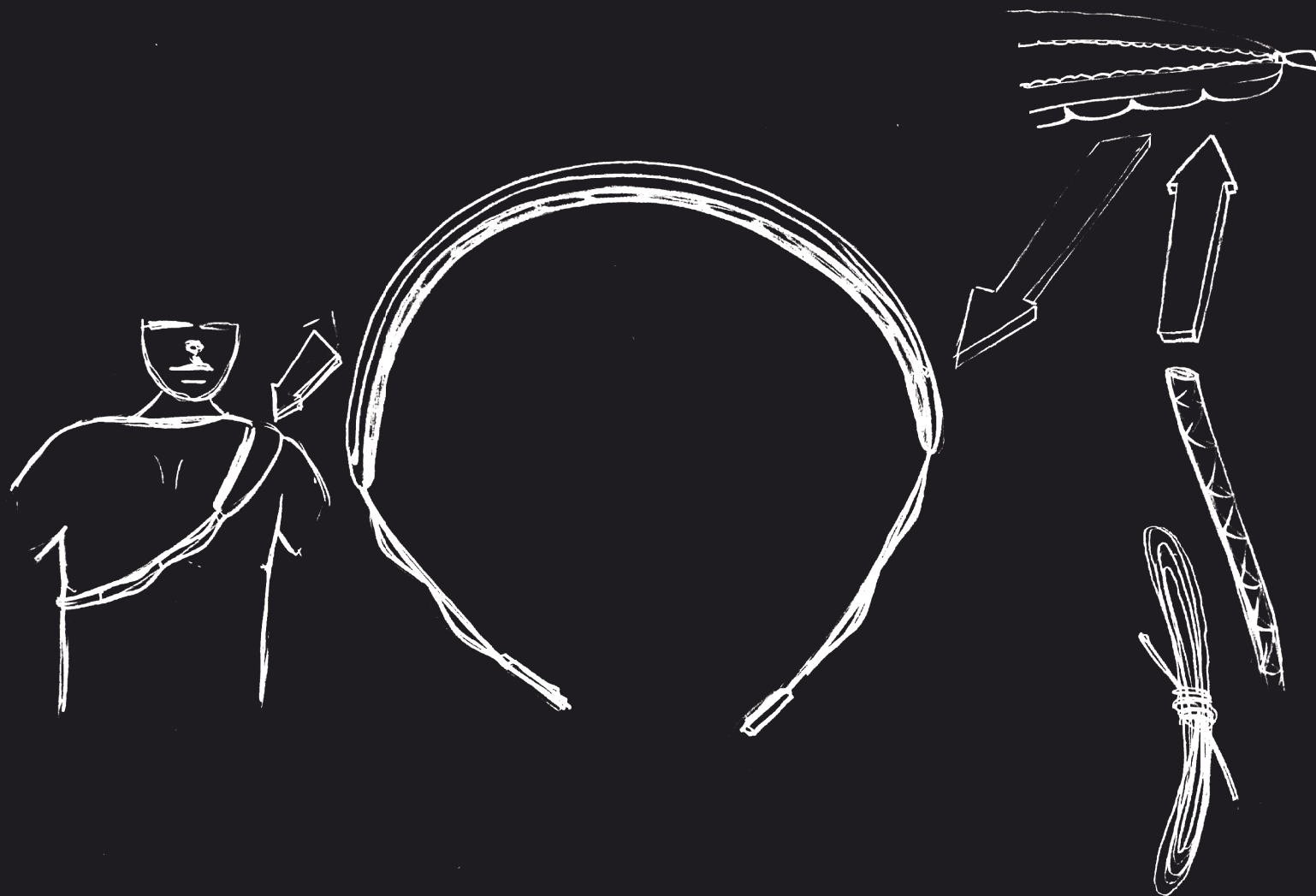

COMBINING GEAR

BRACE BEARD

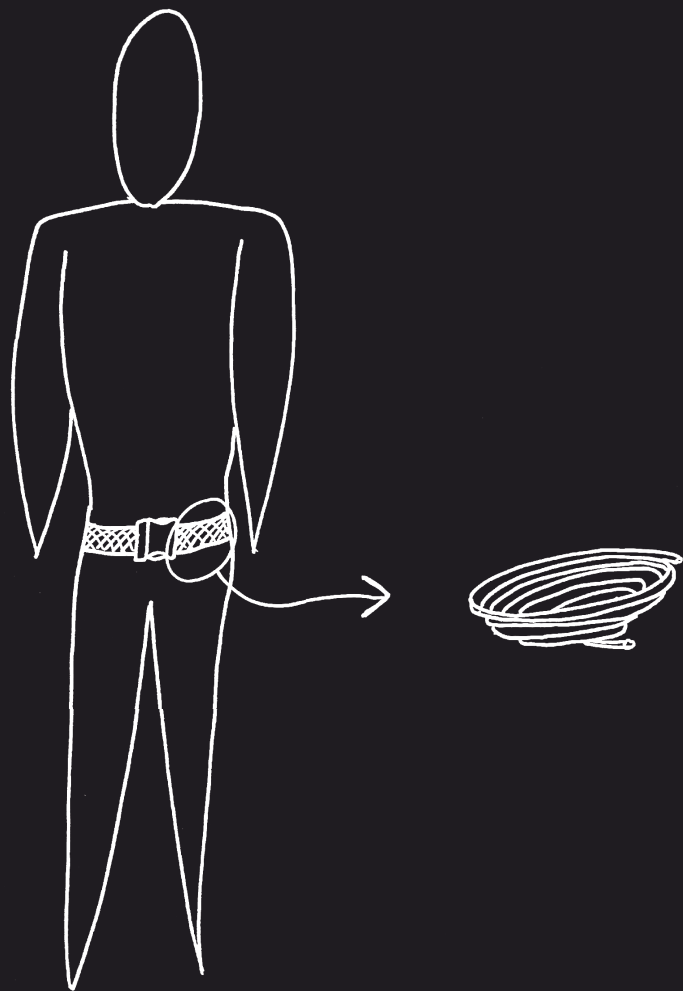

COMBINING GEAR

PADDING GEAR

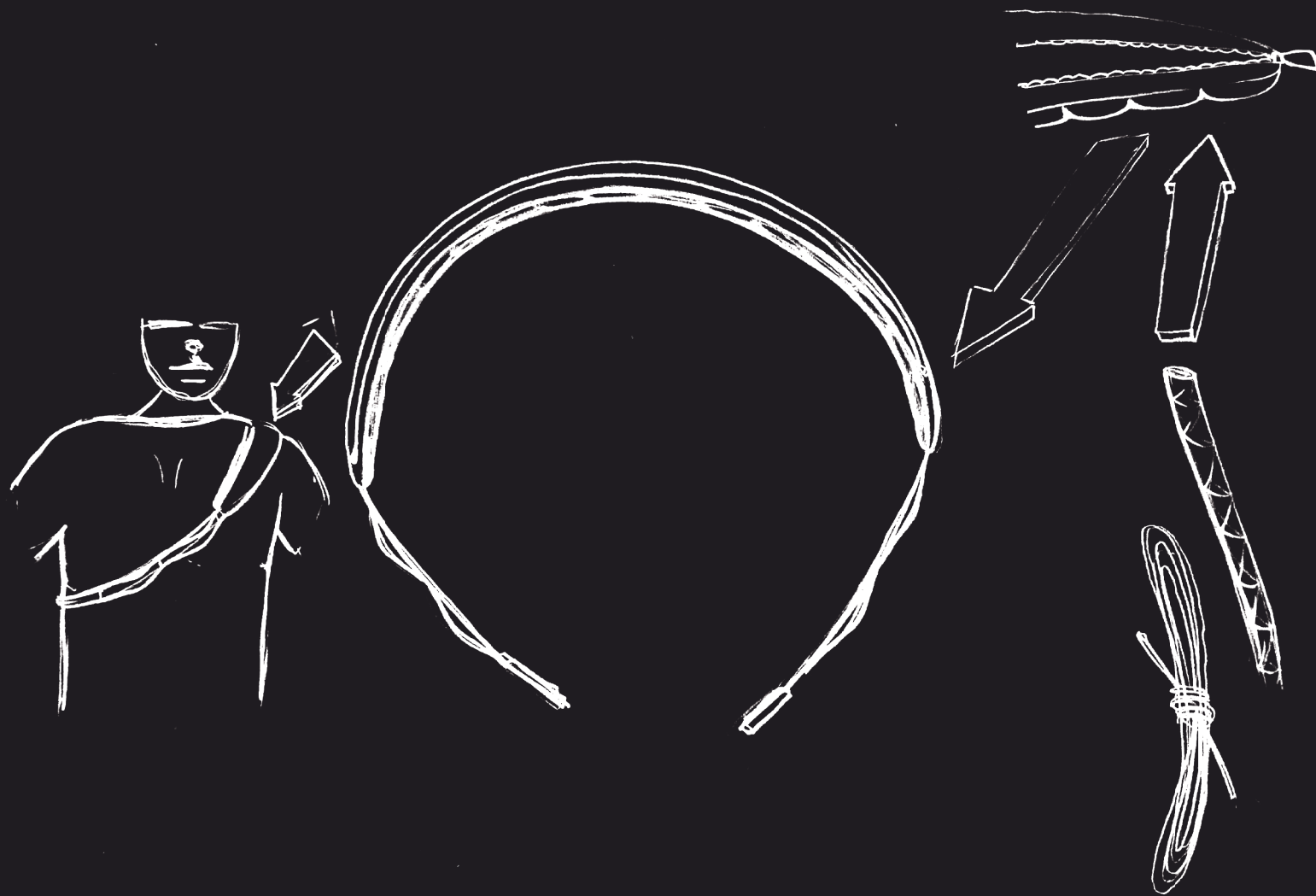

COMBINING GEAR

BRAGE RBEARD

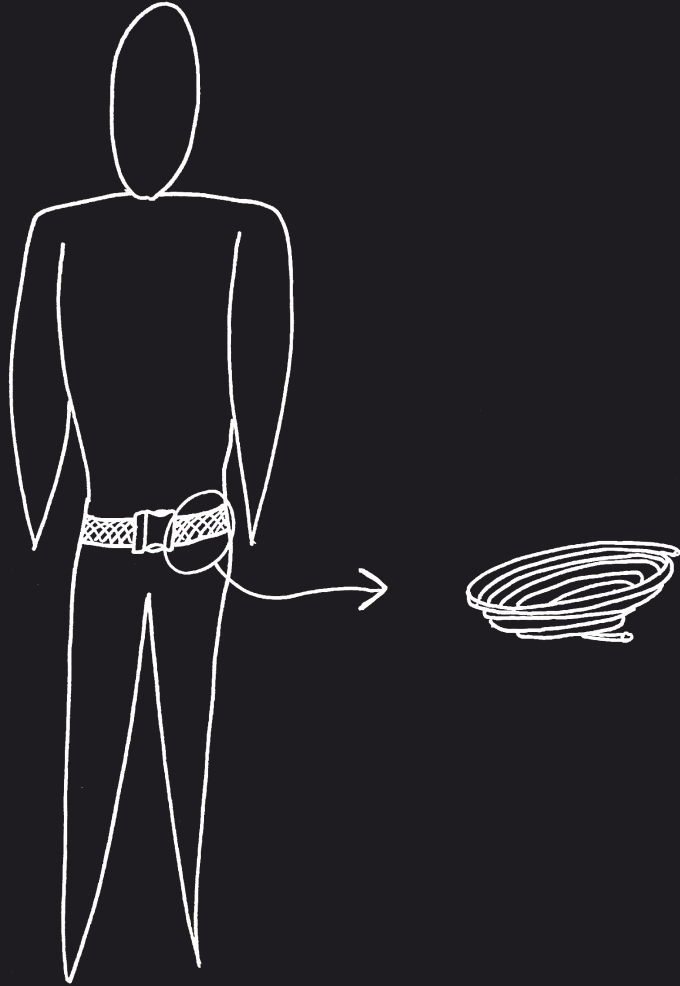

COMBINING GEAR

FIRST AID KIT

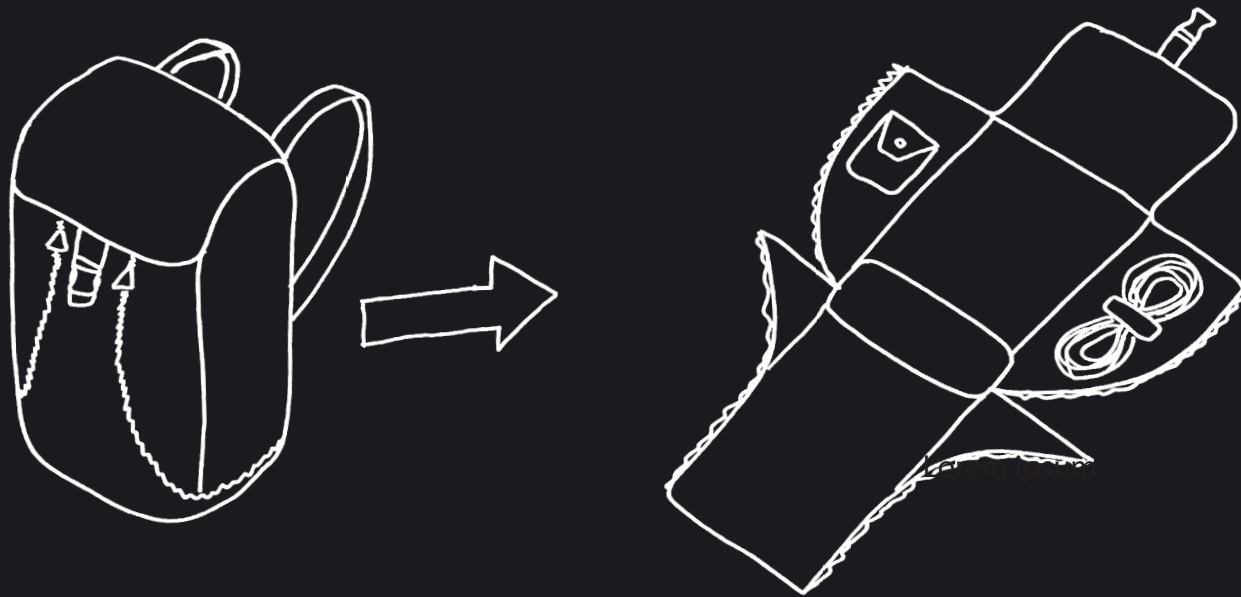

COMBINING GEAR

AMMOCK

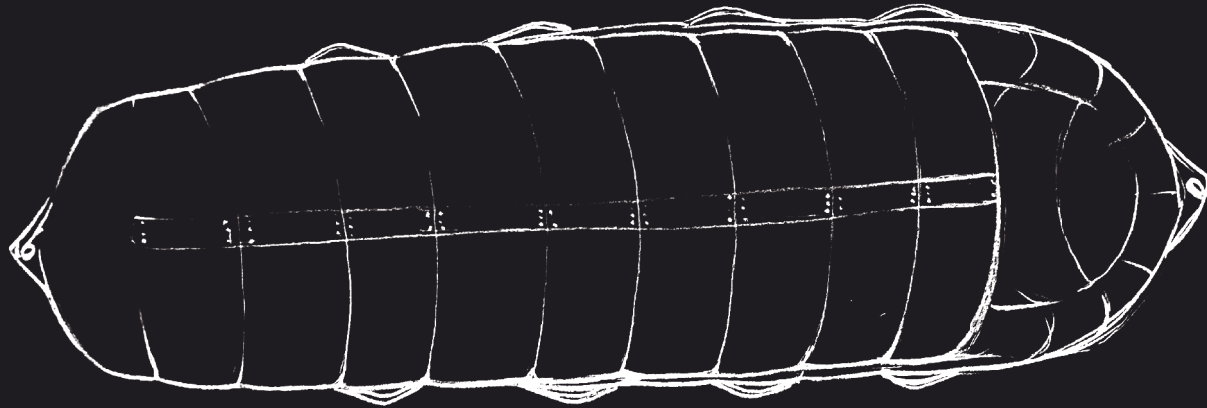

ECONOMY

SOLE CHANGING SHOES

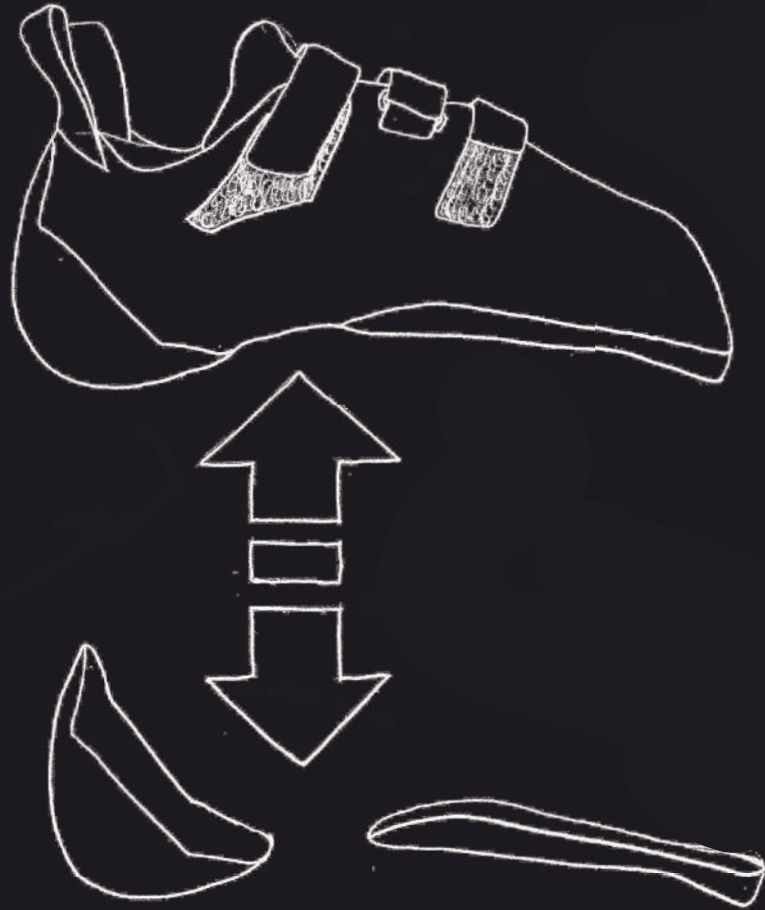

SOCIAL

APP

facebook ⇒ existing solution

↓
Collecting relevant information

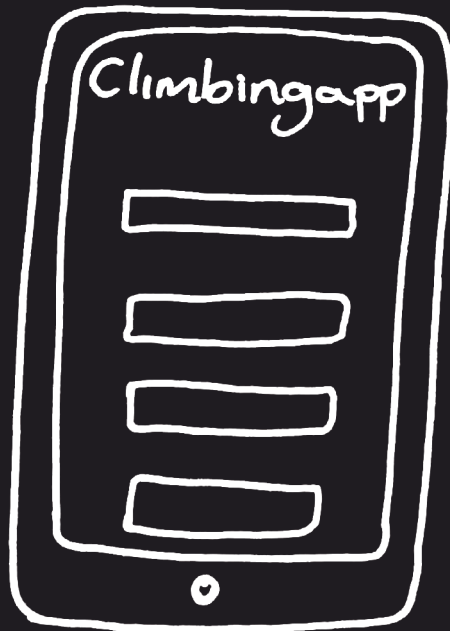

- Planning
- Coordination
- Getting in Contact
- Finding Climbing routes
- Interests
- visited places
- experience
- rating system
- remembering list

Exploration of arrangement

circular

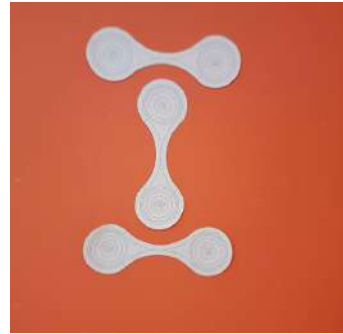
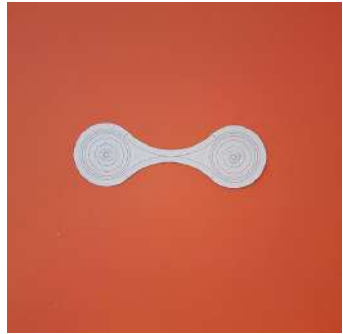
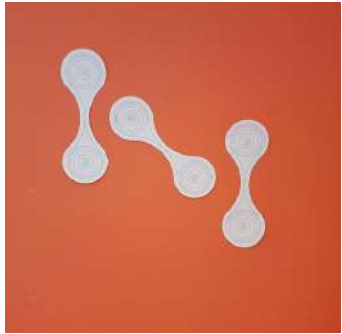
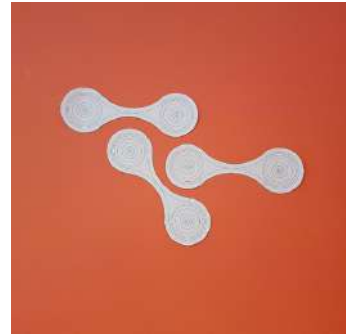
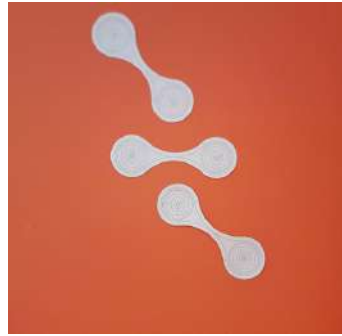
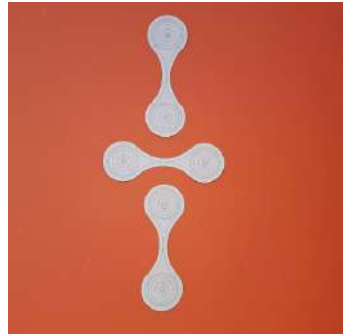
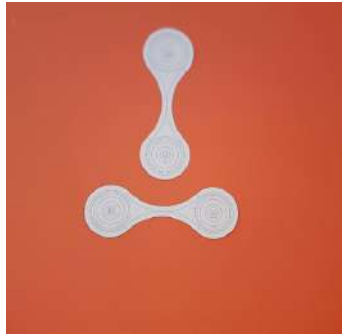
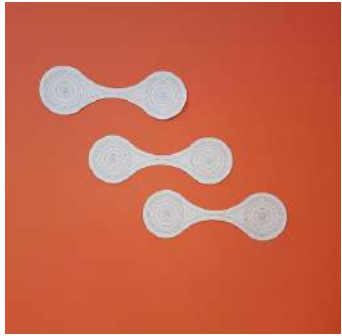

RAPID PROTOTYPES



Mounting part

In this picture its shown how the mounting part is supposed to be if produced. This is a difference to the part shown in the report by this having a circular shape on the part thats supposed to be fixed to the wall.

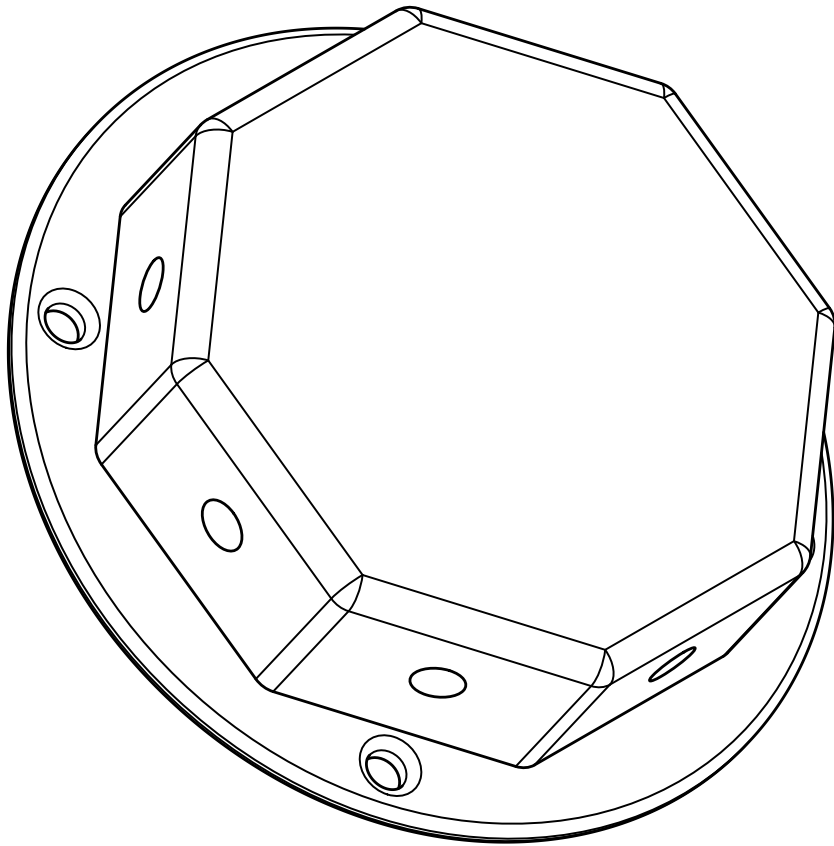

Testing of resistance

The photos is from testing the resistance of the product. Before testing, the mounting part and the piece is assembled, there is also a restriction of weight hanging on the wall to get an such exact result as possible. In the testing different amounts of weight has been added, by doing this, its safe to say that the product is safe for normal use.

The colours represent the the different amount of pressure points on the piece, the red en-lightens the weakest spots.

This goes for further making of the concrete in use, where more strenght will be added to these points.

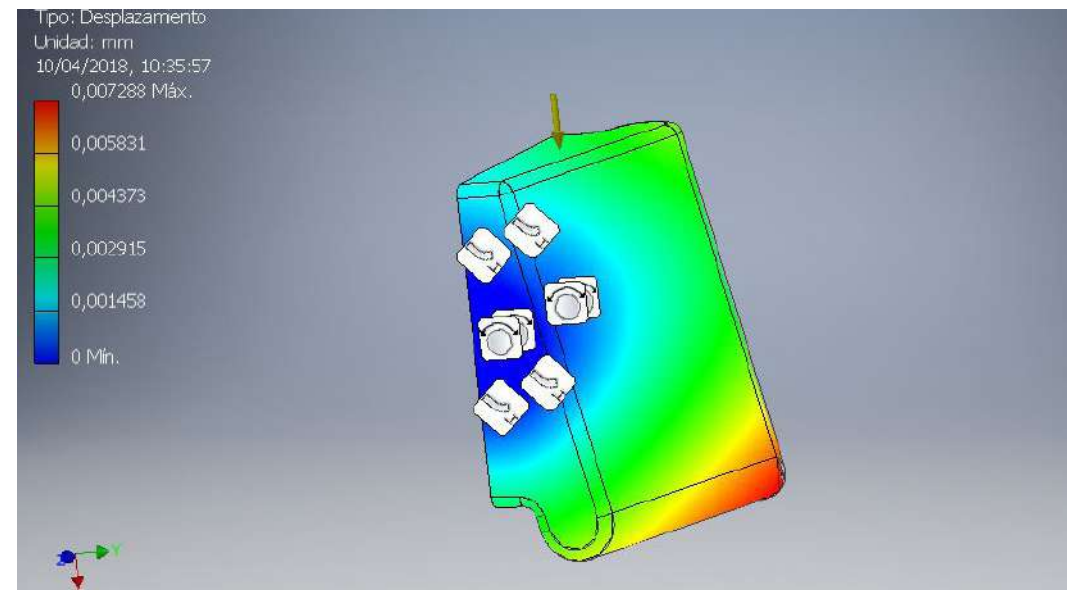
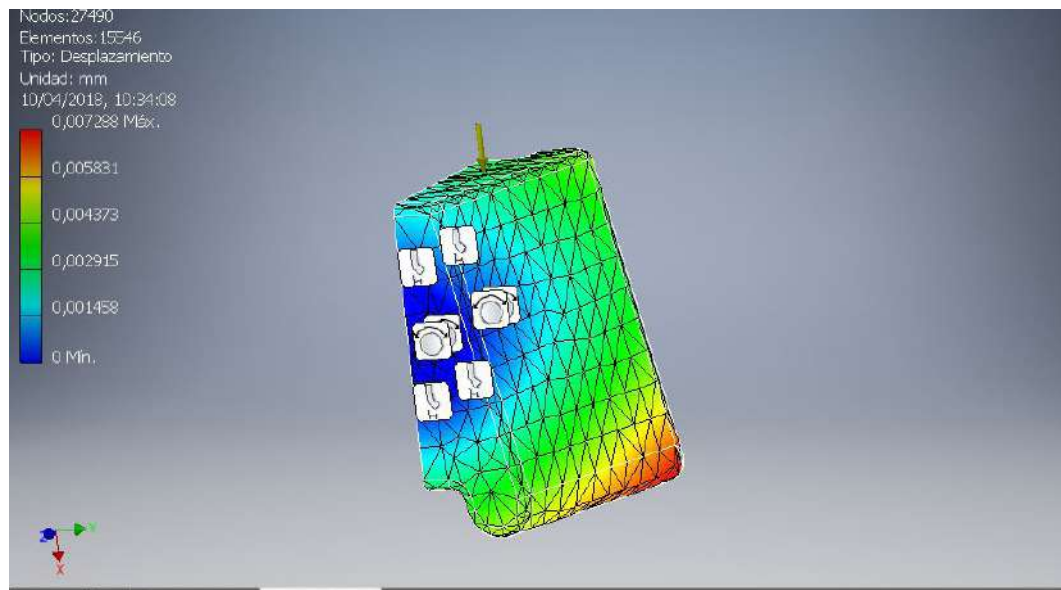

REFLECTION

NOTE OF REFLECTION

CELIA MANZANO CASTELLANOS

This course has been enriching for me, but at the same time challenging for myself. Begin able to communicate in a good way my thoughts and ideas in my non mother language was, and still is, a bit difficult for me. But without any doubt, I would chose again coming to Norway and participate in this course if I had the opportunity.

I have learned a lot about the first steps in the design process. It fulfills my education as a real designer, understanding from the first touch with the user to the engeneering manufacturing. But not only the topic we deal with is rewarding, but also the possibility of be immerse in a total different educational system. It is fascinating how much resources and constructives feedbacks you get from everyone around the school.

Also working hand in hand with two norweigan boys have been funny, stressful and restorative at the same time. It is sometimes just imposible to not laught under missunderstanding or want to kill someone when they don't see your point of view because of cultural background.

About the subject planning, I think is really useful have a week workshop course to develop different skills. but at the same time you never feel finished properly a task and sometimes that is so stressfull. So is somehow a double-edged sword.

Puntualised that my favourite part of the course was iteration/implementation, where we really start to work with your hands and discuss with your group. I think that making rapid mock-ups or really well definate prototype helps us to improve the design and perfect the concept. The reason why I valorate this so much is because in Spain this phase usually never exists, and I found it a complete error.

To sum up quickly: it was one of my best educational experience, I would recomed it without a debt.

NOTE OF REFLECTION

By Oddmund Lilletofte

So far in the bachelor course this subject seems to be what have given me the greatest learning outcome. First of all because i have been forced to practise english speaking and writing allmost every day, thanks to be grouped with an exchange student. This has had even more benefits such as seeing her skills in other computer programs and social settings. That is something I would choose again if the opportunity comes up.

Another reason is learning how to do proper research out in the field. Learning how to gather information by doing interviews with the technique of active listening has been a really important part of this, and then get to now how to analyze and organize the information.

Attending the folding workshop with Jule Weibel was another thing that made this subject. Her work were inspiririg, showing me different ways of working with paper that I on beforehand did'nt know about. Learning how to do it myself and how to do this with other materials as well, is something I will pick up again and continue experimenting with.

It felt like I came a bit short when it came to academic writing, but when looking back at the first sketches, I can easely se the progress. This training will also gain me in the future, when more academic writing is needed.

Summed up, I have really enjoyed this subject and I'm feeling proud of the work my group has put down in this project.

REFLEKSJON KULTURFORSTÅELSE

Stian Luneborg

Self mappingen

Følte at prosjekter virkelig startet etter vi hadde presentert self mappingen. Klassen delte seg inn i grupper og jeg bestemte meg for å jobbe med Oddmund og Celia som er en utvekslingsstudent fra Spania. Det å velge en utvekslingsstudent tenkte jeg kunne være smart med tanke på at de sitter på andre kunnskaper.

Gruppeindelig og research

Vi gikk igjennom self mappingen og begynte å gjøre opp oss tanker om hva vi skulle jobbe med. Vi var innom en del forskjellige temaer før vi til slutt endte opp med klatring, noe jeg tror vi alle synes virket spennende. Vi begynte raskt med research gjorde avtaler med forskjellige mennesker og dro på klatresentrene snakket med folk, noe vi fikk stort utbytte av. Ukes kurse med Richard, følte jeg det ødla flyten i researchen, men lærings utbytte tror jeg kom godt med, det å være effektiv. Richard er veldig god lærer og en vi skulle hatt mer av.

Konsepter

Etter research begynte vi å tenke på forskjellige Konsepter, vi var innom flere forskjellige temaer og endte opp med hjemme trening

Hjemmetrening

Trur den største grunne for at vi endte opp med hjemme treing var at vi så et vakuum, der produktene var lite utviklet med tanke på hjemme og atmosfæren vi vill bo i.

Frame

Frame var navnet vi valgte å gi det endelige produktet med tanke på grunn av den firkantete formen. Veien får å komme til dette produktet bruke vi mye tid jobbe med forskjellige former og funksjon.

Oppsummering

Helheten i dette evner føler jeg at det har vårt mye fokus på designer metodikk, noe jeg har hatt stort utbytte av, og ikke helt forstått før nå. mye av grunnen til dette er mye oppfølging og tydelige

WORKSHOP

WORKSHOP

CELIA'S WORKSHOP

When the three different options for workshops were presented I had no doubt which one I was going to choose. Having the opportunity of living such a big traditional Norwegian thing as it is camping in nature was definitely something I had to do before leaving Norway. This course gave me the opportunity of experiencing such an amazing adventure.

At the beginning, sleeping outside with temperatures below zero degrees looked not really nice. For introducing ourselves in the nature we should be prepared. That is why Einar gave all the participants, including the Belgian students that came to also live the experience, some camping tips for beginners. After that, we created aleatory groups to work with a whole week and went out to do a bit of research about camping equipment.

The next morning we were ready to live what it really means to spend a day in nature. The teachers of this course fulfilled us with all the required gear to survive. When we arrived to our spot, we started preparing everything for making a fire, eating and sleeping. As I found quite difficult describing all the feelings we got, not only freezing ourselves, I attach some photos.



Photos of the camping day. Photos by Celia Manzano

WORKSHOP

CELIA'S WORKSHOP

On Wednesday we were back at school disposed to work in our new task: improving camping experience. Thanks to have had lived how it feels, brainstorming technique gave us several interesting concepts. Each one of the group made and top three and then we chose the most popular idea, a light diffuser.

The concept of developing a light diffuser was based on the problem of been inside the tent with only a focused light. We not only created a lamp, furthermore we developed a piece of equipment that tries to diffused light of any flashlight (headflashlight and normal ones) making our product versatile. The real product is represented and explained in the poster attached, but we also prototype trying to find the most real solution

On Friday all the course meet and showed the result of their work, also the textil and folding textile.

As a reflection I think it was a rewarding experience. Working with different cultural backgrounds and different methodologies helps to open your mind and learn new things. Also the fact that I actually enjoy camping make my impression of this workshop so much better.

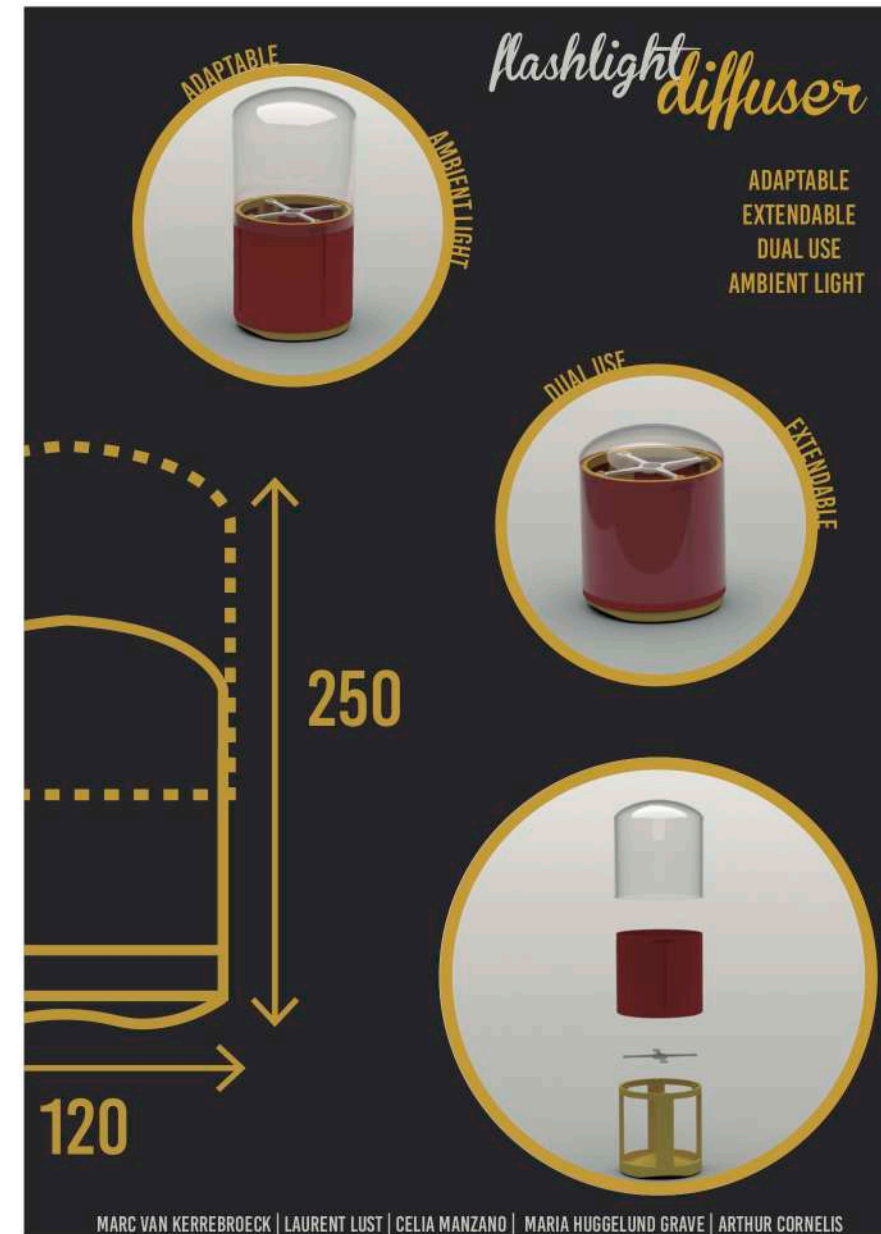

Flashlightdiffuser poster. Illustrated by Celia Manzano

Folding workshop w/ Jule Weibel

By Oddmund Lilletofte

This workshop started with an lecture from Jule where she talked about her work. How she started up with folding and where her work has taken her.

Further she showed us some of her work that she had brought here. That showed how you can use the folding techniques on other materials than just paper.

She then went through the proses of folding, drawing, make lines with folding knife and then the order of how to fold.

Already the first day, after getting inspired by Jule, we started with one basic folding technique. This was collapses in one direction as shown on the pictures to the right.

This is drawn as arrows pointing in the same direction.

When doing this I was amazed by how this was possible without tearing the paper.

The whole first day was about mastering this technique.

The next days we were getting introduced to two new ways of folding, one that makes it possible to make a double curvature, and that naturally arching whn folded, this is shown all to the right. The other technique was how to make 90° foldings to make corners.



Photos by Oddmund Lilletofte

Folding workshop w/ Jule Weibel

The next days we were assigned to work by ourselves and get help if needed. This was to practise the different techniques and on our own try to combine and further experiment with other ways of folding. The way of doing this was trying and failing while composing different foldings.

When doing this we were going to prepare for the exhibition, planning a set up and showing our progression.

To plan what to show was a bit difficult within this time timeframe, because at this point in the course the outcome was unpredictable.

After folding for some days the behavior of the paper began to be understood.

In the top right photo is one of the templates made to fold one of the objects on the exhibition. The picture under shows some of the different objects made while working in the course.

All to the right is what the final setup was on the exhibition.

This represents a collapsable in the way that it evolves from something small, widens out and goes up in to another shape.

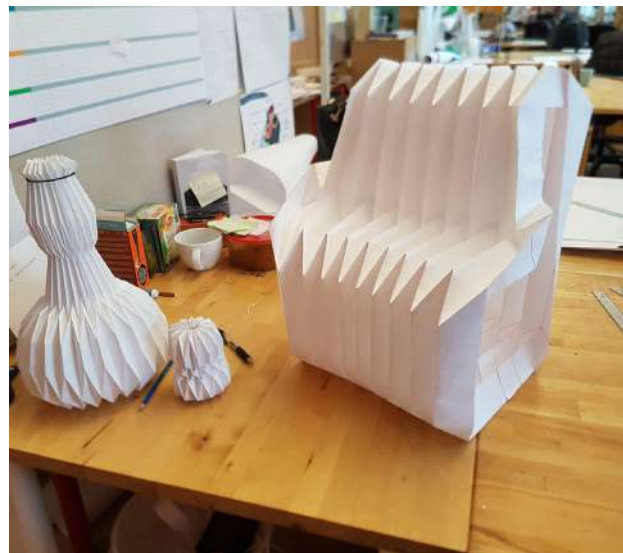
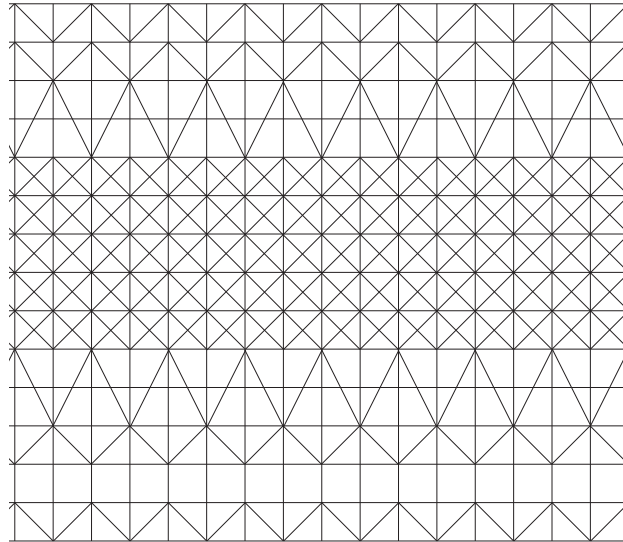

Photos by Oddmund Lilletofte





Workshop
Med. Marie O'Mahony

Hybrid tekstil

Hybrid tekstil er å blande et eller flere materialer med tekstil, foreksempel et tynt lag skifer og filt, for å skape et fleksibelt materiale med stein of tekstil.

Vi ble delt inn i grupper der jeg jobbet med Kirsten, Marthine, Mette og Siri. vi skulle lage en karakter vi så skulle lage et produkt/tekstil til. vi lagde en uban dame med navn steff som bodde i berlin.

Mitt arbeid

Jeg valgte og jobbe med tre og tekstil. det jeg gjorde var å lime tynne lag med finer på tekstil.

for å skape ekstra fleksibilitet laser kuttet jeg igjennom det første laget med finer i forskjellige mønster. Fant ut at bomull var det mest egnete bruke av tekstil

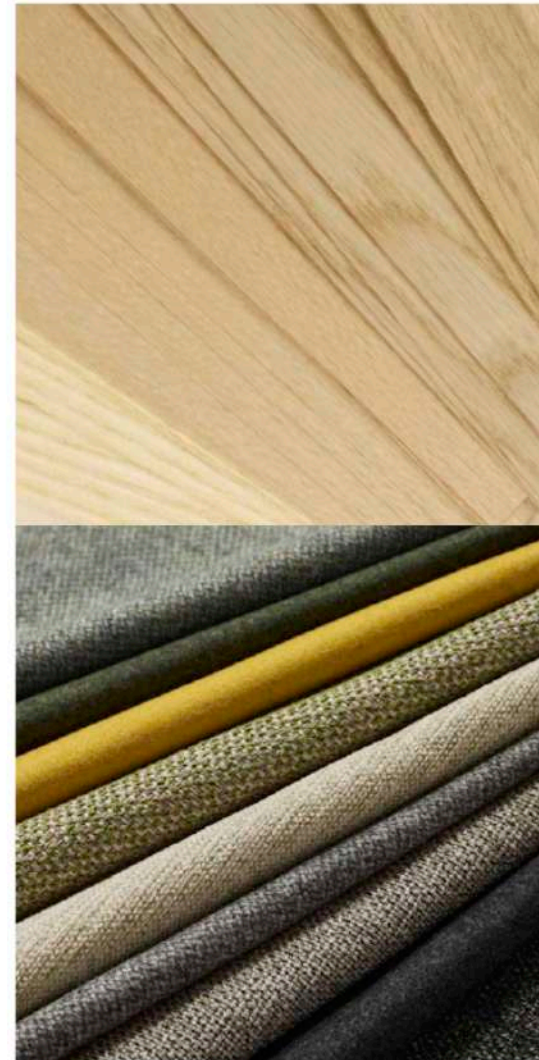

Bjork og svart bomulsfilt

Laser kuttet inn monster av sirkler for å hvor mye mere flesibilitet det kunne tilfoje hybride tekstine, i tillegg fjernet noe av det negative rommet mellom sirklene.

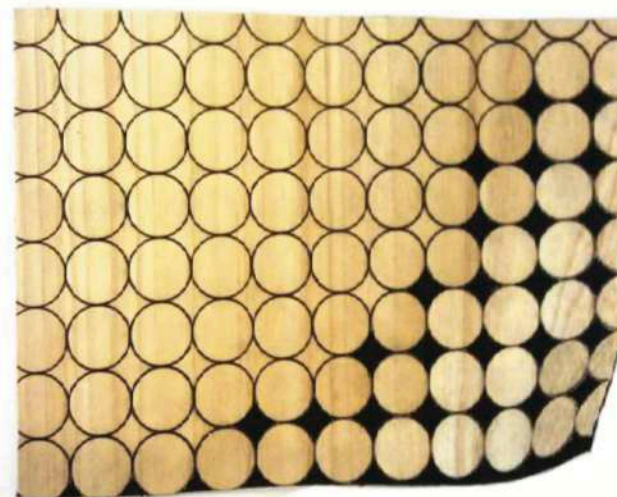

Valnot og svart bomulsfilt

Laser kuttet inne mindre sirkler omringet av kvadrater for å öke fleksibiliteten, valnotten er noe tykkere en bjorken, som gir litt mere utfordringer

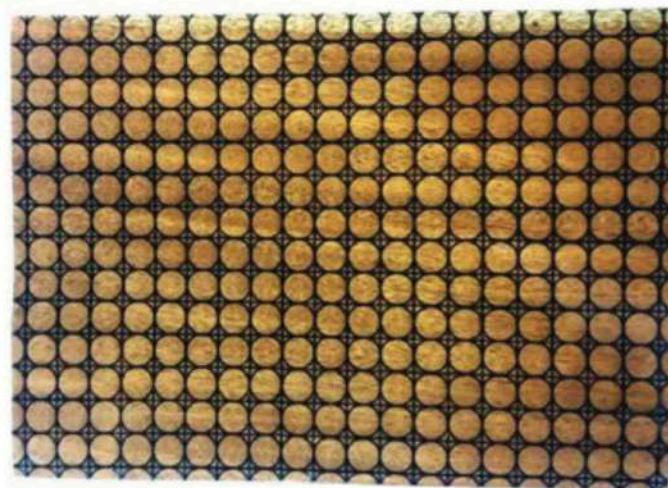

Bork og svart bomulsfilt

Gradert mønsteret over flere omganger, problemet med det er at graderinger forandrer på tre trukturent. hybrid tekstilen flytter på seg å laseren bommer på det mønstert som allerede er gradert. har i tillet lekt med det negative rom.

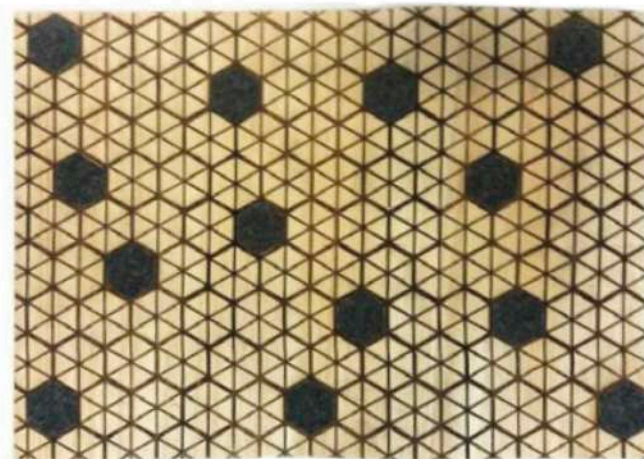

Bök lin og svart bomulsfilt

Laser kuttet et avlangt mønster som krysser fiberretnigen. fungerte utrolig godt. Brukte først lin og finer, men pågrunnnav at Fibrene på linen ble stive av laseren limte jeg på et eksta lag med bomulsfilt.

