

Lista de variables globales: Classification

```
1      {attribute 'qualified_only'}
2      VAR_GLOBAL
3          ClassificationA_Done : BOOL ;
4          ClassificationB_Done : BOOL ;
5          Deleted_Done : BOOL ;
6          Recirculated_Done : BOOL ;
7          N_Pieces_ZoneA : INT := 0 ;
8          N_Pieces_ZoneB : INT := 0 ;
9          N_Pieces_Deleted : INT := 0 ;
10         N_Pieces_Recirculated : INT := 0 ;
11
12         Piece_2ndConveyor : BOOL ;
13
14         Placing_ZoneB : BOOL ;
15         Eliminate_Piece : BOOL ;
16         Placing_ZoneA : BOOL ;
17         recirculating_Piece : BOOL ;
18         Deleting_Piece : BOOL ;
19         Count_Recirc : int ;
20
21     END_VAR
22
```

Lista de variables globales: Colour

```
1      {attribute 'qualified_only'}
2      VAR_GLOBAL
3          BlueA : BOOL ;
4          GreenA : BOOL ;
5          RedA : BOOL ;
6          ColourA : INT ;
7          ColourB : INT ;
8          Colours : ARRAY [ 0 .. 1 , 1 .. 3 ] OF STRING := [ '1' , '2' , '3' , 'Blue' ,
9              'Green' , 'Red' ] ;
10         BlueB : BOOL ;
11         GreenB : BOOL ;
12         RedB : BOOL ;
13     END_VAR
```

Lista de variables globales: Config

```
1      {attribute 'qualified_only'}
2  VAR_GLOBAL
3
4      First_A : BOOL ;
5      Second_A : BOOL ;
6      Third_A : BOOL ;
7      Fourth_A : BOOL ;
8      Fifth_A : BOOL ;
9      Sixth_A : BOOL ;
10     Seventh_A : BOOL ;
11     Eighth_A : BOOL ;
12     Ninth_A : BOOL ;
13     Tenth_A : BOOL ;
14     Eleventh_A : BOOL ;
15     Twelfth_A : BOOL ;
16
17     Zone_A : BOOL ;
18     Zone_B : BOOL ;
19     ValidarA : BOOL ;
20     ValidarB : BOOL ;
21
22     First_B : BOOL ;
23     Second_B : BOOL ;
24     Third_B : BOOL ;
25     Fourth_B : BOOL ;
26     Fifth_B : BOOL ;
27     Sixth_B : BOOL ;
28     Seventh_B : BOOL ;
29     Eighth_B : BOOL ;
30     Ninth_B : BOOL ;
31     Tenth_B : BOOL ;
32     Eleventh_B : BOOL ;
33     Twelfth_B : BOOL ;
34
35
36
37
38
39  END_VAR
40
```

Lista de variables globales: IO

```
1      {attribute 'qualified_only'}
2      VAR_GLOBAL
3          // Photoelectric Sensor 1
4          S1 AT %I* : BOOL ;
5          // Colour Sensor- Red
6          S2_1 AT %I* : BOOL ;
7          // Colour Sensor- Green
8          S2_2 AT %I* : BOOL ;
9          // Colour Sensor- Blue
10         S2_3 AT %I* : BOOL ;
11         // Inductive Sensor 1
12         S3 AT %I* : BOOL ;
13         // Magnetic Sensor 1
14         S4 AT %I* : BOOL ;
15         // Distance Sensor
16         S5 AT %I* : INT ;
17         // Photoelectric Sensor 2
18         S6 AT %I* : BOOL ;
19         // Photoelectric Sensor 3
20         S7 AT %I* : BOOL ;
21         // Magnetic Sensor 2
22         S8 AT %I* : BOOL ;
23         // Inductive Sensor 2
24         S9 AT %I* : BOOL ;
25         // Photoelectric Sensor 4
26         S10 AT %I* : BOOL ;
27
28
29
30         // DC Motor Conveyor Belt 1
31         DC_Motor1 AT %Q* : BOOL ;
32         // DC Motor forward movement Conveyor Belt 2
33         DC_Motor2F AT %Q* : BOOL ;
34         // DC Motor backward movement Conveyor Belt 2
35         DC_Mtor2B AT %Q* : BOOL ;
36
37
38         // Step Motor Horizontal
39         Step_Motor_Horiz AT %Q* : BOOL ;
40         // Step Motor Vertical
41         Step_Motor_Vert AT %Q* : BOOL ;
42
43
44
45         // Limit Switch Up of the Step motor vertical
46         Limit_Switch_Up AT %I* : BOOL ;
47         // Limit Switch Down of the Step motor vertical
48         Limit_Switch_Down AT %I* : BOOL ;
49         // Limit Switch Right of the step motor horizontal
50         Limit_Switch_Right AT %I* : BOOL ;
51         // Limit Switch Left of the step motor horizontal
52         Limit_Switch_Left AT %I* : BOOL ;
53         // Button to start the program
54         B_ON AT %I* : BOOL ;
55         // Button to stop the prgram
56         B_STOP AT %I* : BOOL ;
57         // Emergency button
```

Lista de variables globales: IO

```
58     B_EMERGENCY AT %I* : BOOL ;
59     // Button to restart everything due to a problem
60     B_RESET AT %I* : BOOL ;
61     // Button to start the program
62     B_ON_TouchP AT %I* : BOOL ;
63     // Button to stop the program
64     B_STOP_TouchP AT %I* : BOOL ;
65     // Button to restart everything due to a problem
66     B_RESET_TouchP AT %I* : BOOL ;
67     // Light that shows that the system is running
68     L_ON AT %Q* : BOOL ;
69     // Light that shows that the system is stopped
70     L_STOP AT %Q* : BOOL ;
71     // Light that shows that the system needs to be reset due to a problem
72     L_RESET AT %Q* : BOOL ;
73     // The robot says that the piece is already in the conveyor belt
74     R_Piece_Start AT %I* : BOOL ;
75     // I say to the robot can leave the piece on the conveyor belt
76     R_Can_Leave_Piece AT %Q* : BOOL ;
77     // I say to the robot that it has to take the piece at the end
78     R_Pick_Piece AT %Q* : BOOL ;
79     // The robot says when it already has taken the piece
80     R_Deleted_Piece AT %I* : BOOL ;
81     // Electrovalve to open the gripper
82     EP AT %Q* : BOOL ;
83     // Electrovalve to recirculate a piece
84     ER AT %Q* : BOOL ;
85     // Electrovalve to recirculate a piece return
86     ER_2 AT %Q* : BOOL ;
87
88
89     Axis_SM1 : AXIS_REF ;
90     Axis_SM2 : AXIS_REF ;
91     DC_Motor2 : AXIS_REF ;
92
93
94     L_Config_Done : BOOL ;
95     L_S3 : BOOL ;
96     L_S4 : BOOL ;
97     L_S8 : BOOL ;
98     L_S9 : BOOL ;
99     Validate_all : BOOL ;
100    Manual : BOOL ;
101    Auto : BOOL ;
102    L_S1 : BOOL ;
103    L_S6 : BOOL ;
104    L_S7 : BOOL ;
105    L_S10 : BOOL ;
106    Distance AT %I* : INT ;
107    Home_SM1 : BOOL ;
108    Home_SM2 : BOOL ;
109    Radius : REAL := 2.5 ;
110    Motor_steps : REAL ;
111
112    DC_Motor2_ON : BOOL ;
113    Axis_SM1_ON : BOOL ;
```

Lista de variables globales: IO

```
114      Axis_SM2_ON : BOOL ;
115
116      Speed_SM1 : LREAL := 70.0 ;
117      Speed_SM2 : LREAL := 80.0 ;
118      Speed_DCM2 : LREAL := 1500.0 ;
119
120      Actual_Position_SM1 : LREAL ;
121      Actual_Position_SM2 : LREAL ;
122      Pos0 : LREAL ;
123      Pos1 : LREAL ;
124      Pos2 : LREAL ;
125      Pos3 : LREAL ;
126      Pos4 : LREAL ;
127      Pos5 : LREAL ;
128      DC_Motor2_OFF : BOOL ;
129      Heigth : REAL := 4 ;
130      stop : BOOL ;
131      Reset_Config : BOOL := 1 ;
132      Reset_Config_yes : BOOL ;
133      Reset_config_No : BOOL ;
134
135
136      END_VAR
137
```

Lista de variables globales: Magnetic

```
1      {attribute 'qualified_only'}
2      VAR_GLOBAL
3          YesA : BOOL ;
4          NoA : BOOL ;
5          MagneticA : INT ;
6          MagneticB : INT ;
7          Magnetics : ARRAY [ 0 .. 1 , 1 .. 2 ] OF STRING := [ '1' , '2' , 'Magnetic' ,
8              'No-Magnetic' ] ;
9          YesB : BOOL ;
10         NoB : BOOL ;
11     END_VAR
```

```
1      {attribute 'qualified_only'}
2  VAR_GLOBAL
3      DC_M1_ON : BOOL ;
4      DC_M1_OFF : BOOL ;
5      DC_M2_F_ON : BOOL ;
6      DC_M2_B_ON : BOOL ;
7      DC_M2_OFF : BOOL ;
8      SM1_ON : BOOL ;
9      SM1_F : BOOL ;
10     SM1_B : BOOL ;
11     SM1_OFF : BOOL ;
12     SM2_ON : BOOL ;
13     SM2_F : BOOL ;
14     SM2_B : BOOL ;
15     SM2_OFF : BOOL ;
16     EP : BOOL ;
17     ER : BOOL ;
18     ER_2 : BOOL ;
19
20     L_DC_M1_ON : BOOL ;
21     L_DC_M1_OFF : BOOL ;
22     L_DC_M2_F_ON : BOOL ;
23     L_DC_M2_B_ON : BOOL ;
24     L_DC_M2_OFF : BOOL ;
25     L_SM1_F_ON : BOOL ;
26     L_SM1_B_ON : BOOL ;
27     L_SM1_OFF : BOOL ;
28     L_SM2_F_ON : BOOL ;
29     L_SM2_B_ON : BOOL ;
30     L_SM2_OFF : BOOL ;
31     L_EP_ON : BOOL ;
32     L_EP_OFF : BOOL ;
33     L_ER_ON : BOOL ;
34     L_ER_2_ON : BOOL ;
35 END_VAR
36
```

Lista de variables globales: Material

```
1      {attribute 'qualified_only'}
2      VAR_GLOBAL
3          MetalA : BOOL ;
4          OtherA : BOOL ;
5          MaterialA : INT ;
6          MaterialB : INT ;
7          Materials : ARRAY [ 0 .. 1 , 1 .. 2 ] OF STRING := [ '1' , '2' , 'Metal' ,
8              'Other' ] ;
9          MetalB : BOOL ;
9          OtherB : BOOL ;
10     END_VAR
11
```

Lista de variables globales: Output

```
1      {attribute 'qualified_only'}
2      VAR_GLOBAL
3          DC_M1_ON : BOOL ;
4          DC_M1_ON_Manual : BOOL ;
5          MOTORS_ON : bool ;
6          DC_M2_ON : BOOL ;
7          DC_M2_ON_Manual : BOOL ;
8          EV_GRIPPER : BOOL ;
9          EV_RECIRC : BOOL ;
10         EV_RETURN : BOOL ;
11         EV_GRIPPER_Manual : BOOL ;
12         EV_RECIRC_Manual : BOOL ;
13         EV_RETURN_Manual : BOOL ;
14     END_VAR
15
```

Lista de variables globales: Sec

```
1      {attribute 'qualified_only'}
2      VAR_GLOBAL
3          ON : BOOL ;
4          off : BOOL ;
5      END_VAR
6
```

Lista de variables globales: Sensors

```
1      {attribute 'qualified_only'}
2      VAR_GLOBAL
3          S1 : BOOL ;
4          S2_1 : BOOL ;
5          S2_2 : BOOL ;
6          S2_3 : BOOL ;
7          S3 : BOOL ;
8          S4 : BOOL ;
9          S5 : BOOL ;
10         S6 : BOOL ;
11         S7 : BOOL ;
12         S8 : BOOL ;
13         S9 : BOOL ;
14     END_VAR
15
```

Lista de variables globales: Steps

```
1      {attribute 'qualified_only'}
2      VAR_GLOBAL
3          STEP1 : BOOL ;
4          STEP2 : BOOL ;
5          STEP3 : BOOL ;
6          STEP4 : BOOL ;
7          STEP5 : BOOL ;
8          STEP6 : BOOL ;
9          STEP0 : BOOL ;
10     END_VAR
11
```

POU: _1_MAIN

```
1  PROGRAM _1_MAIN
2  VAR
3  END_VAR
4
```

```
1  _4_Security ();
2  _5_Configuration ();
3  _8_touch_Panel ();
4  _2_inputs ();
5  _6_Cycle ();
6  _7_Manual_Mov ();
7  _3_Outputs ();
8
```

POU: _2_Inputs

```
1  PROGRAM _2_Inputs
2  VAR
3      Bridgel : BOOL ;
4      MC_Reset_SM1 : MC_Reset ;
5      MC_Reset_SM2 : MC_Reset ;
6      MC_Reset_DCM2 : MC_Reset ;
7  END_VAR
8
```



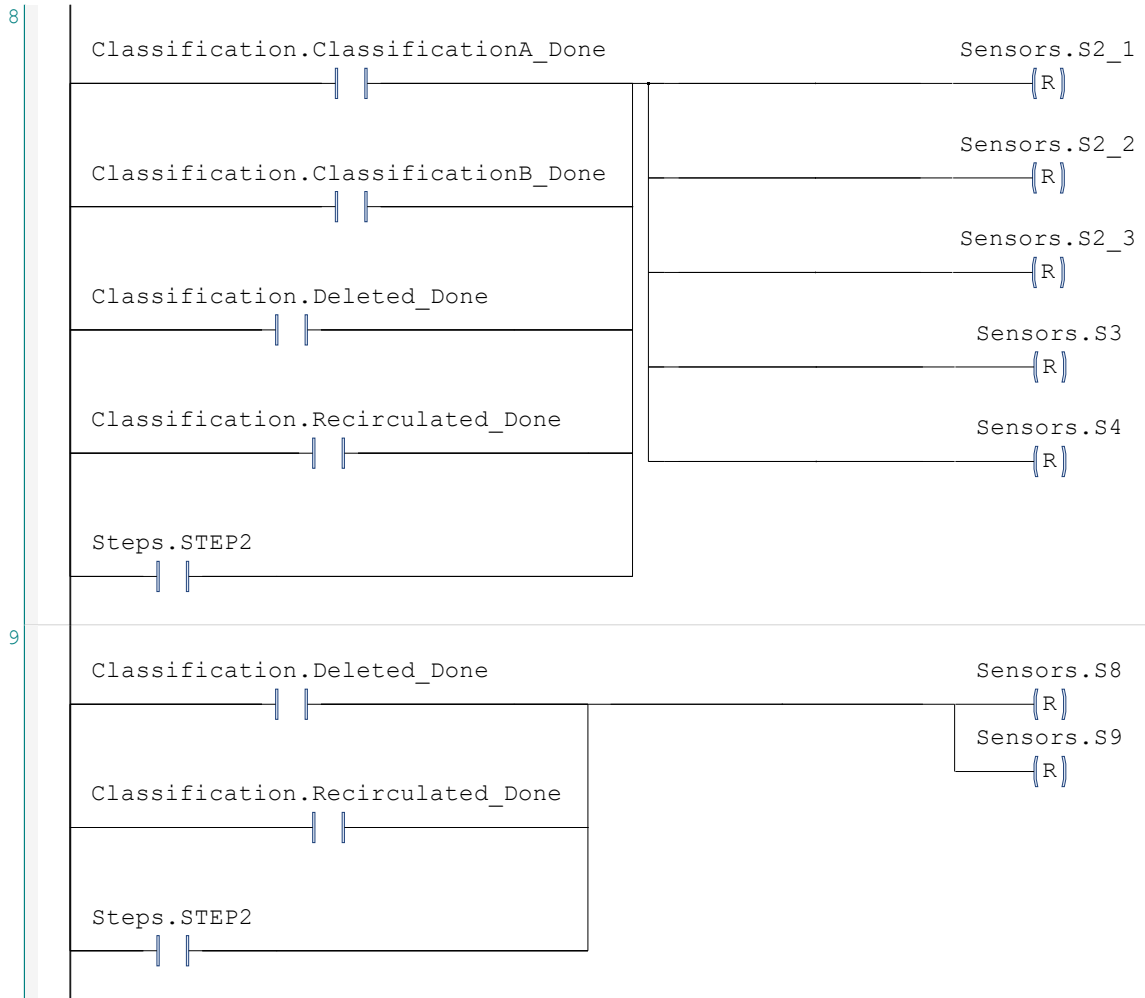

10

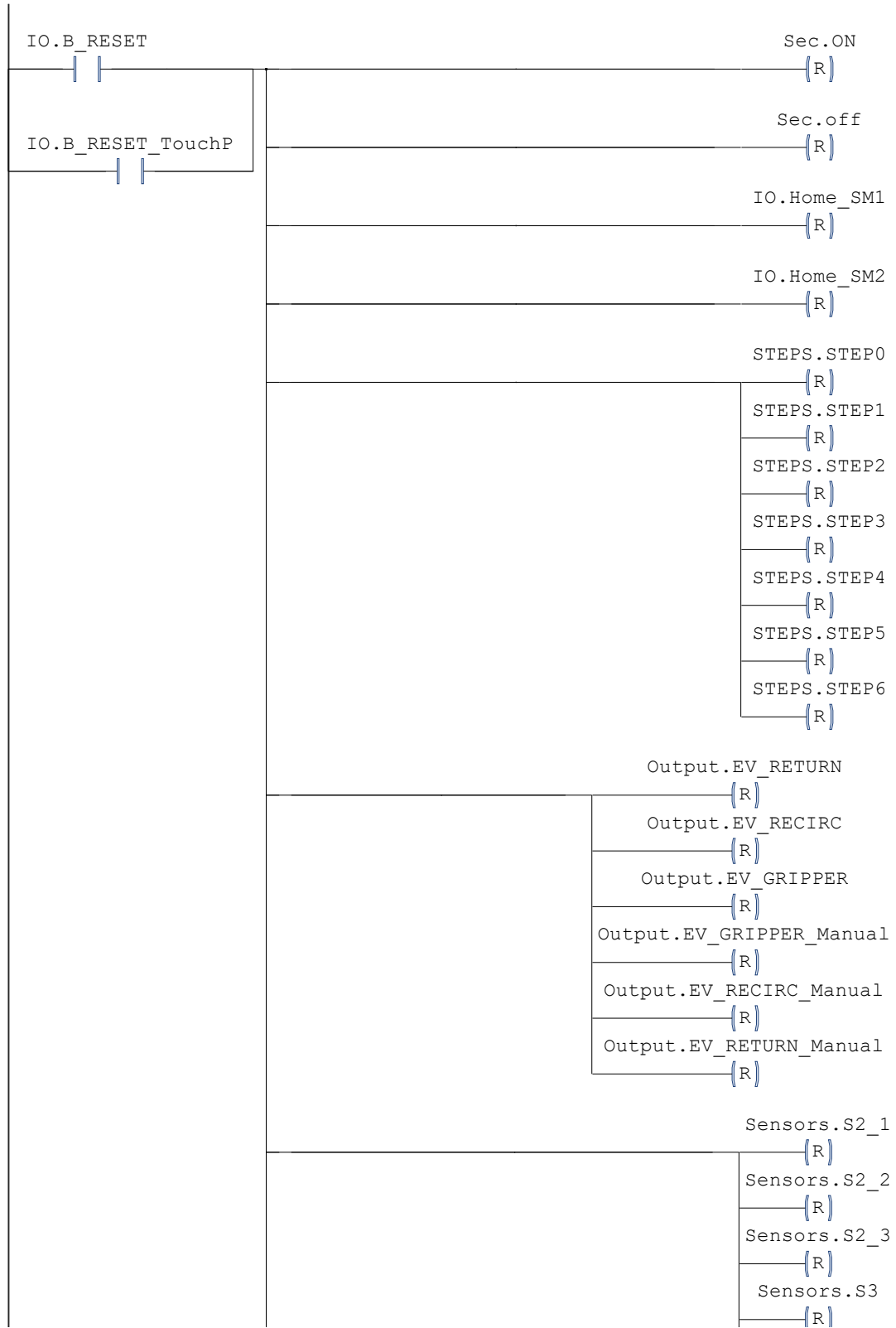

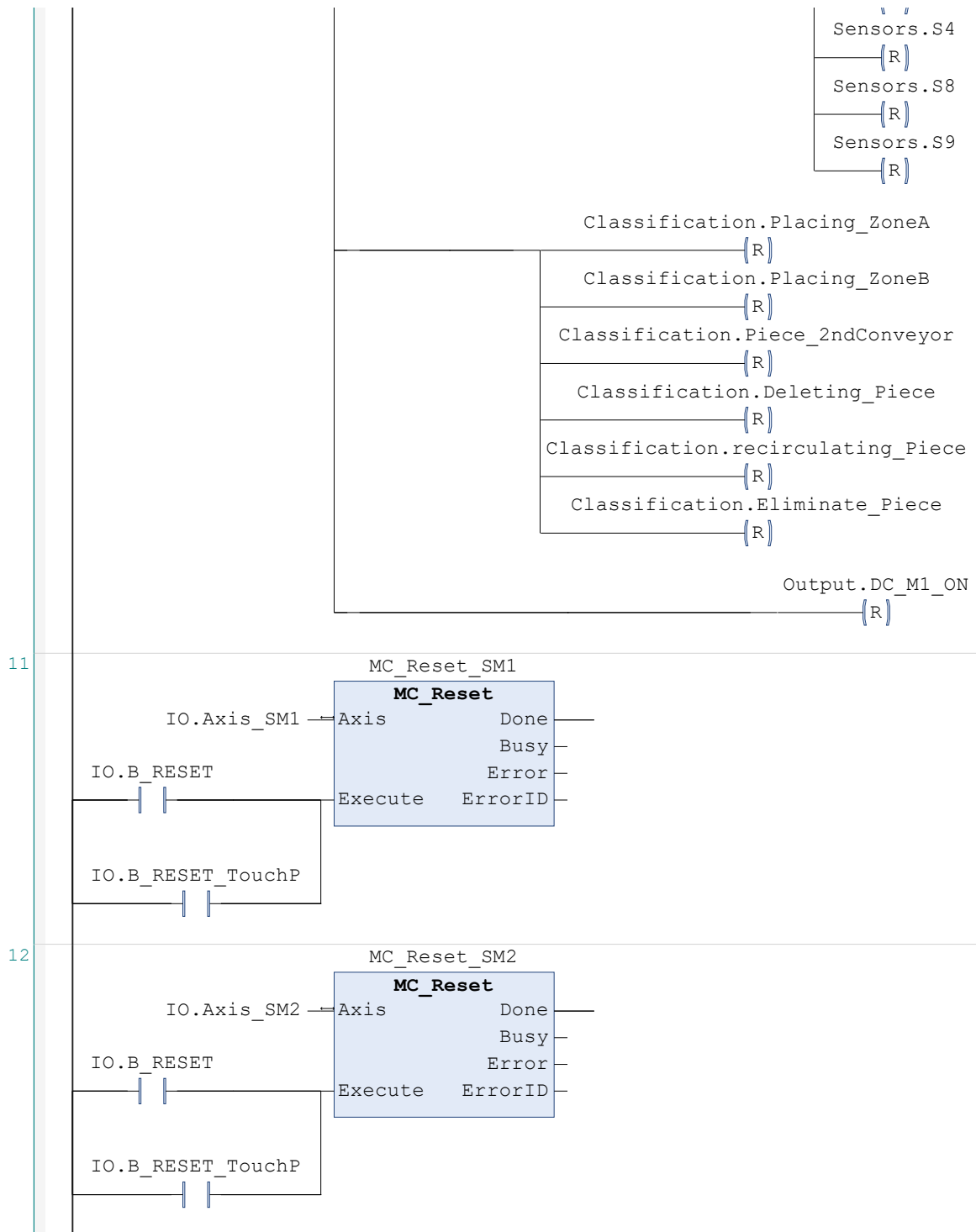

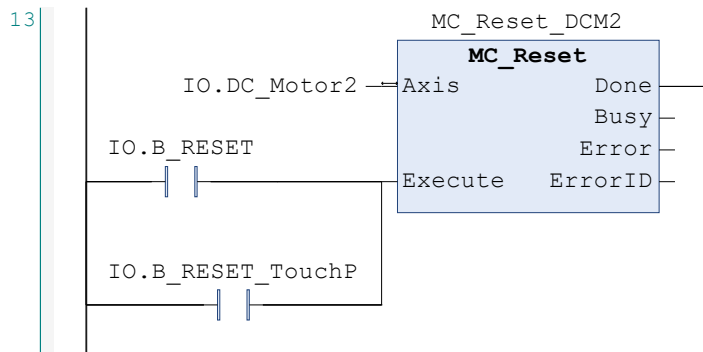

POU: _3_Outputs

```

1  PROGRAM _3_Outputs
2  VAR
3      Power_DC_M2 : MC_Power ;
4      Power_Axis_SM_1 : MC_Power ;
5      Power_Axis_SM_2 : MC_Power ;
6      Stop_Axis_SM_1 : MC_Stop ;
7      Stop_Axis_SM_2 : MC_Stop ;
8      Stop_Axis_DCM2 : MC_Stop ;
9  END_VAR
10

```

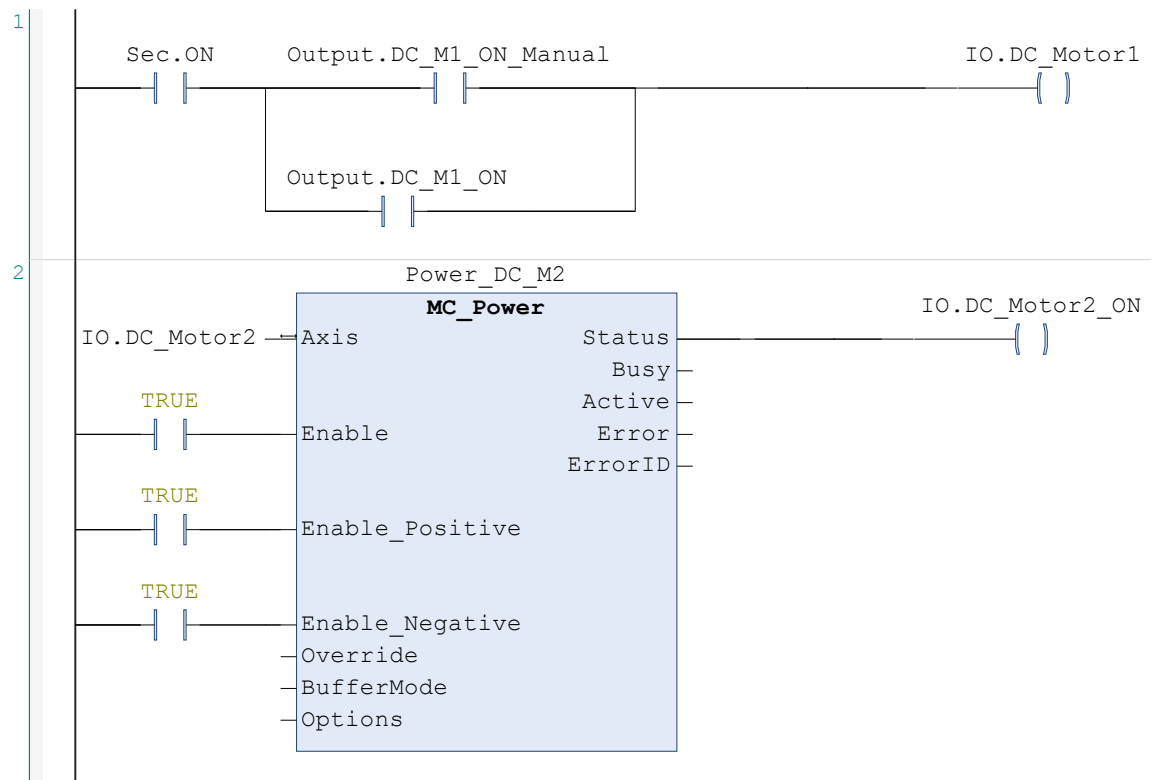

POU: _3_Outputs

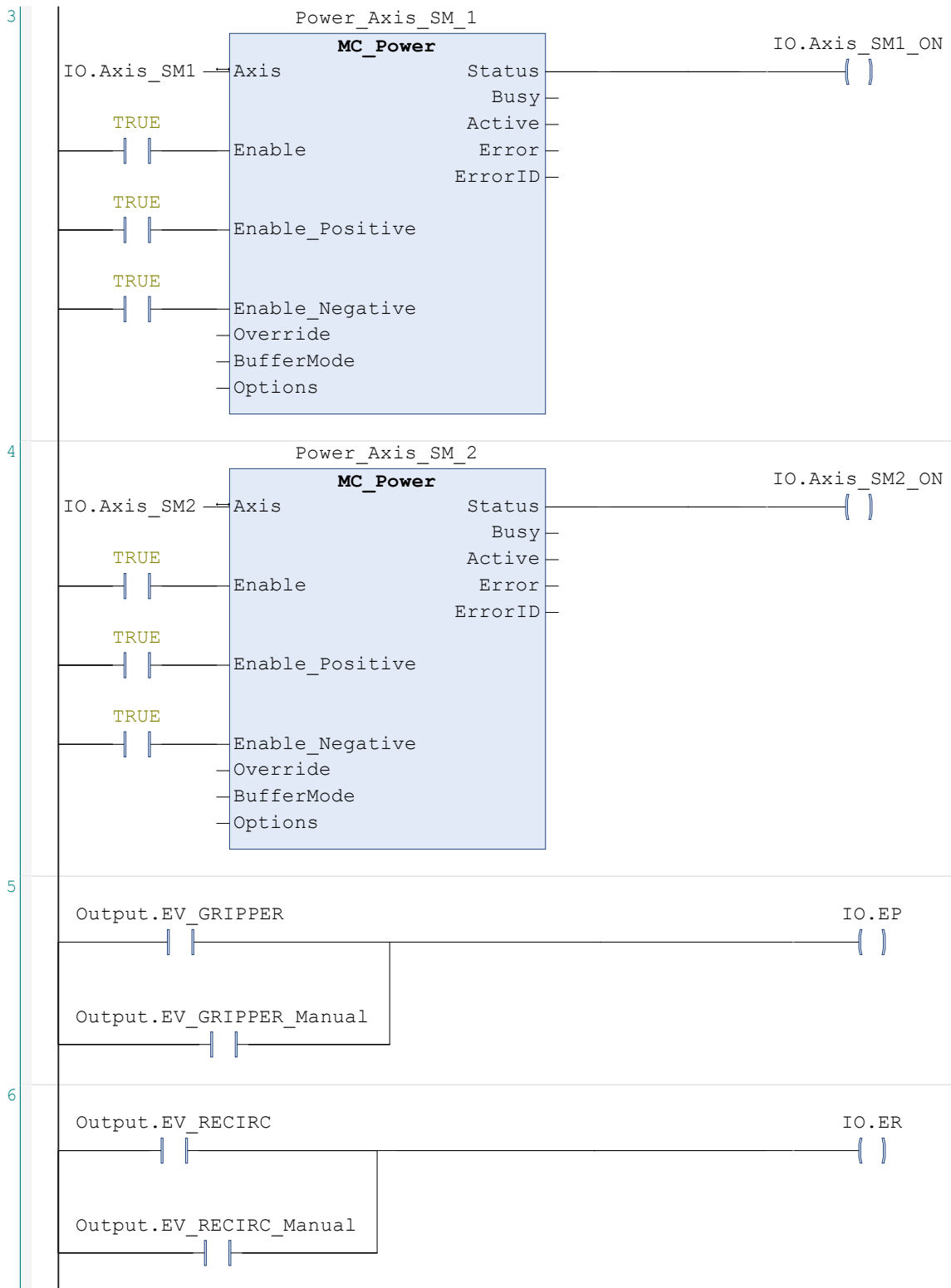

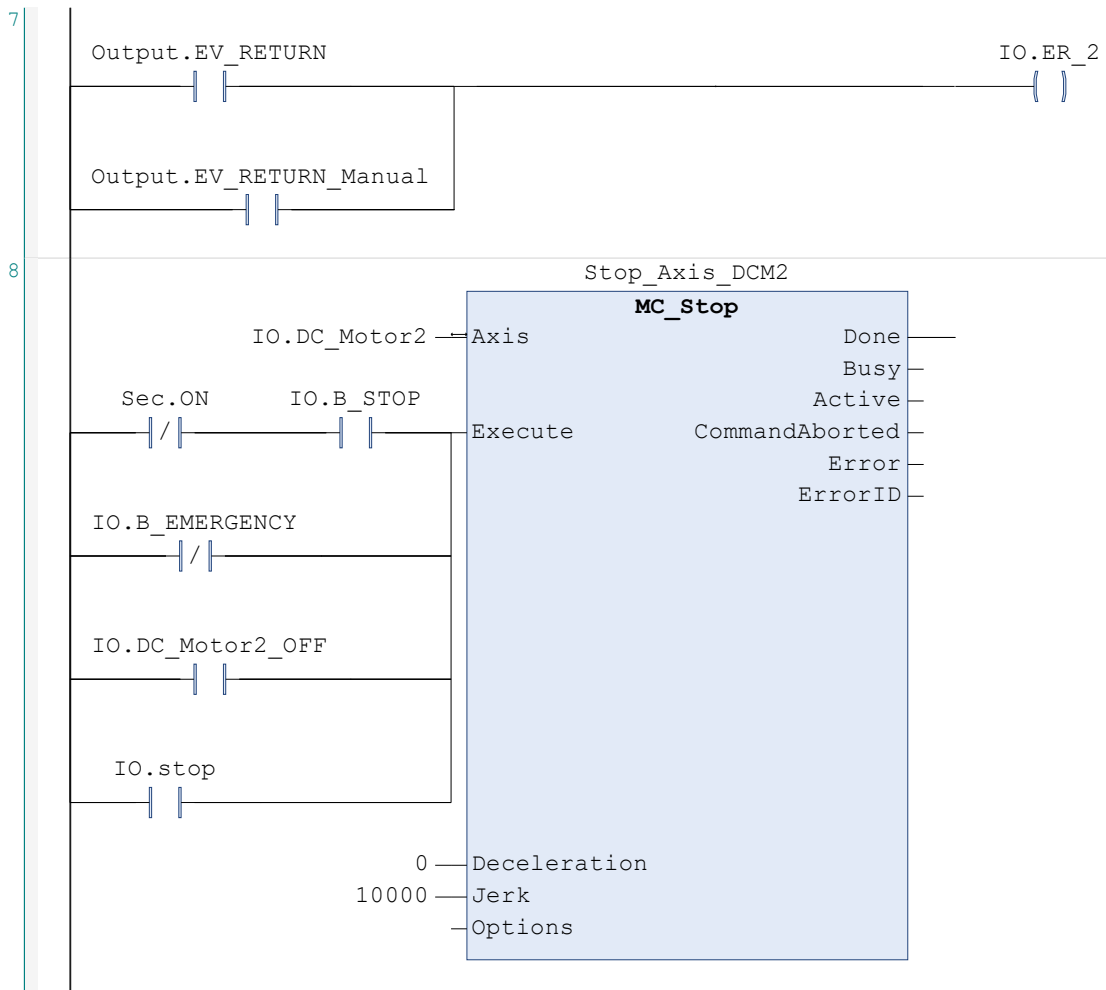

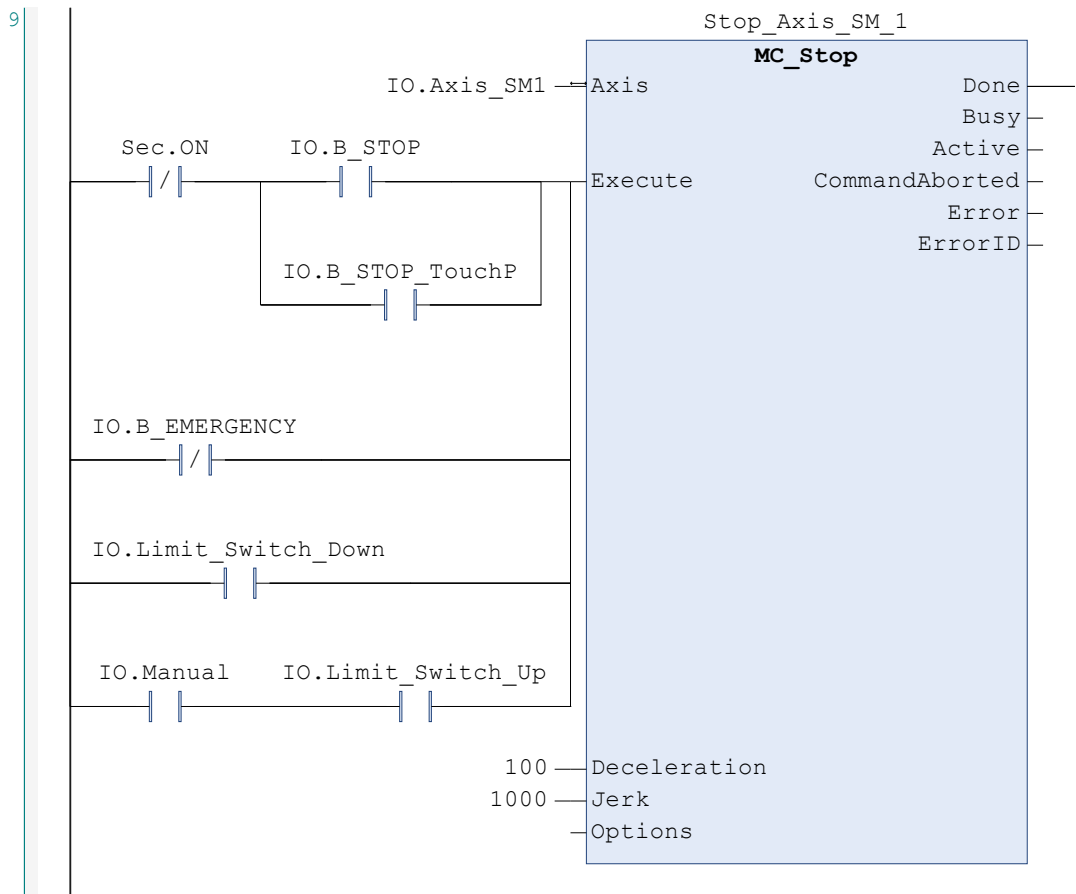

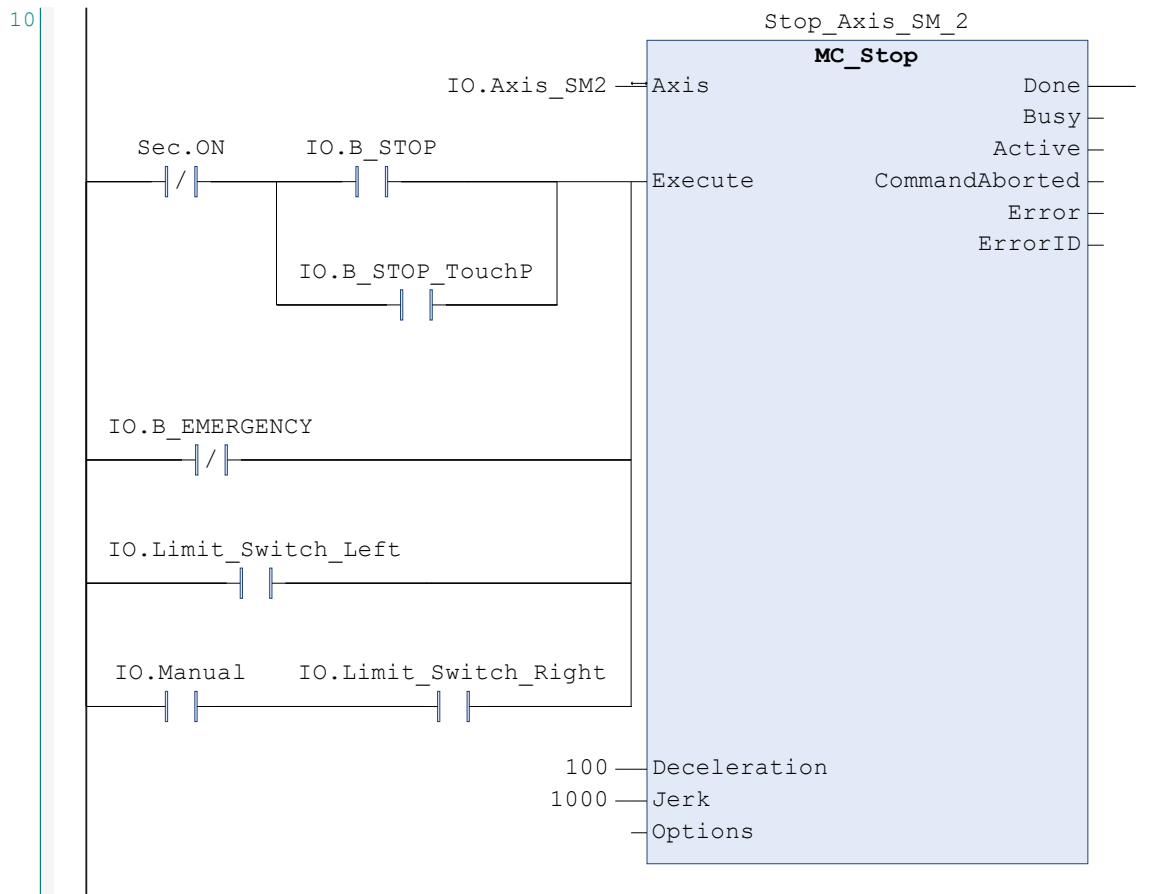

POU: _4_Security

```
1 PROGRAM _4_Security
2 VAR
3 END_VAR
4
```

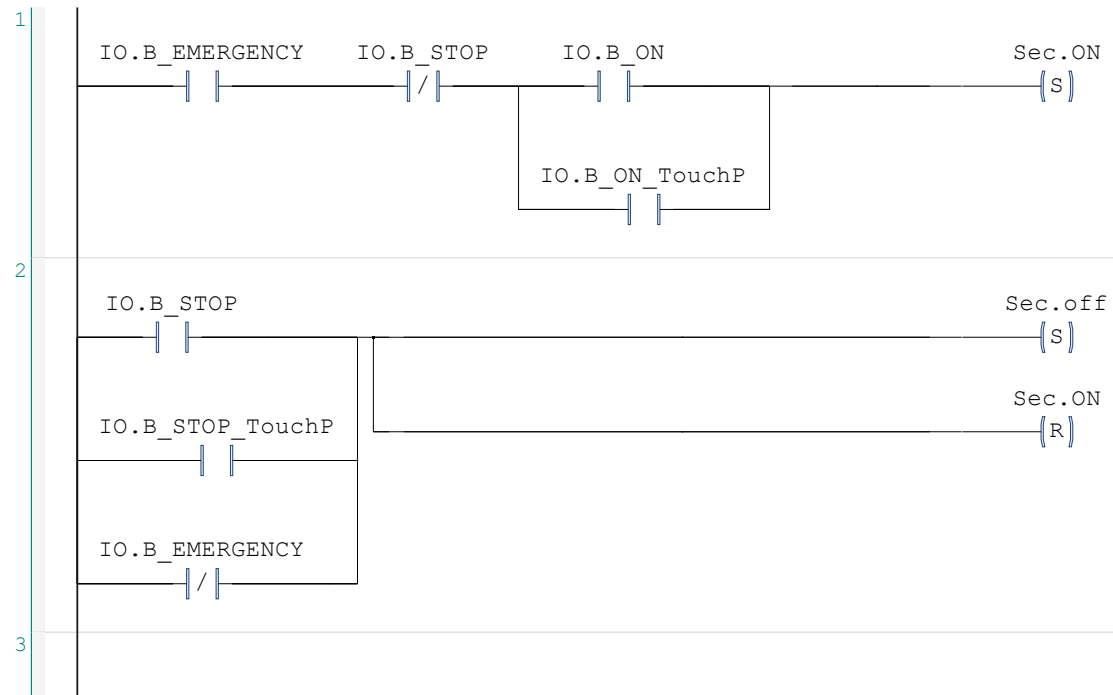

POU: _5_Configuration

```
1  PROGRAM _5_Configuration
2
3  VAR
4      IDZoneA : INT ;
5      IDZoneB : INT ;
6      r_trig1 : R_TRIG ;
7      R_TRIG_0 : R_TRIG ;
8      TON_0 : TON ;
9  END_VAR
10
```

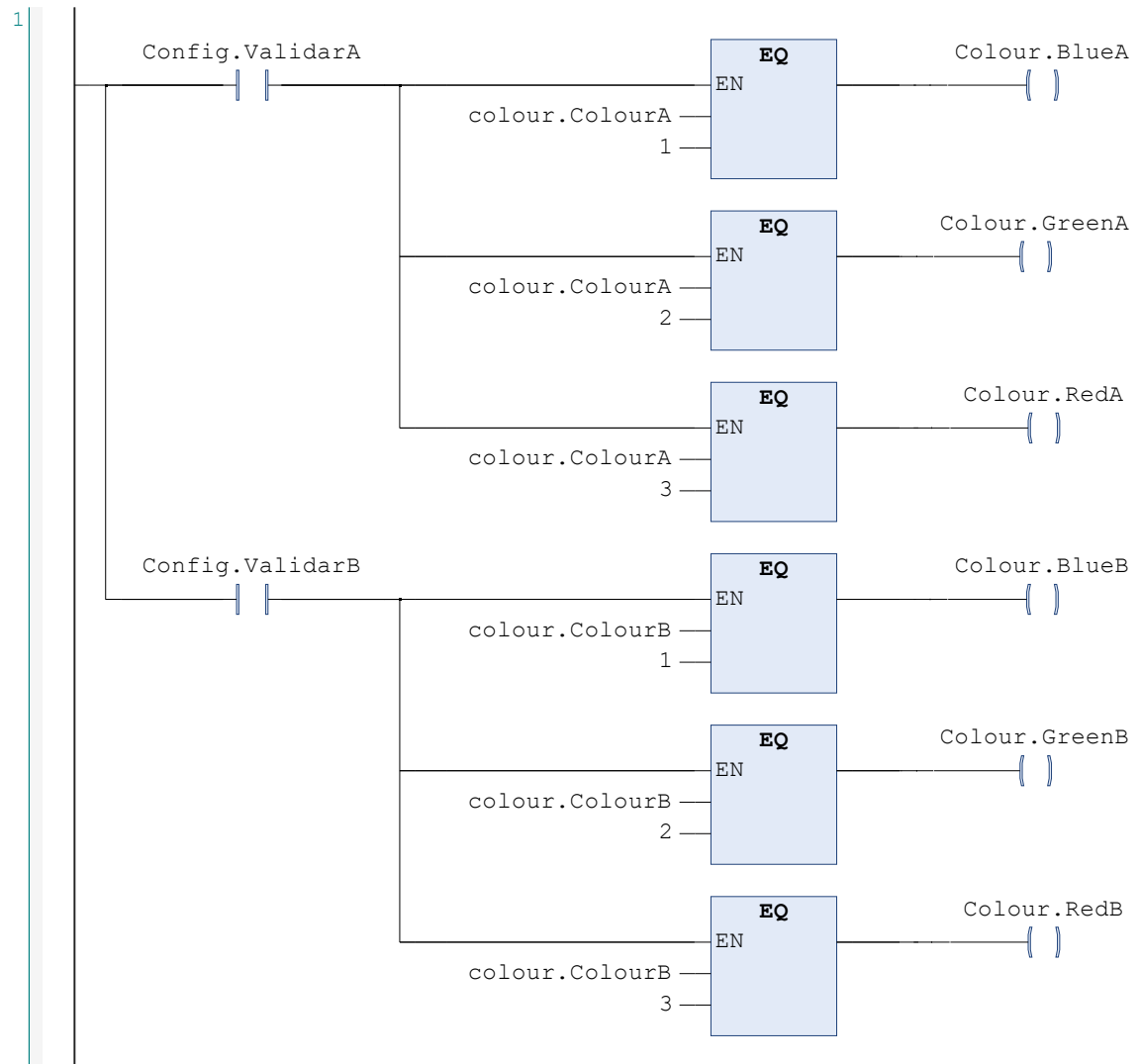

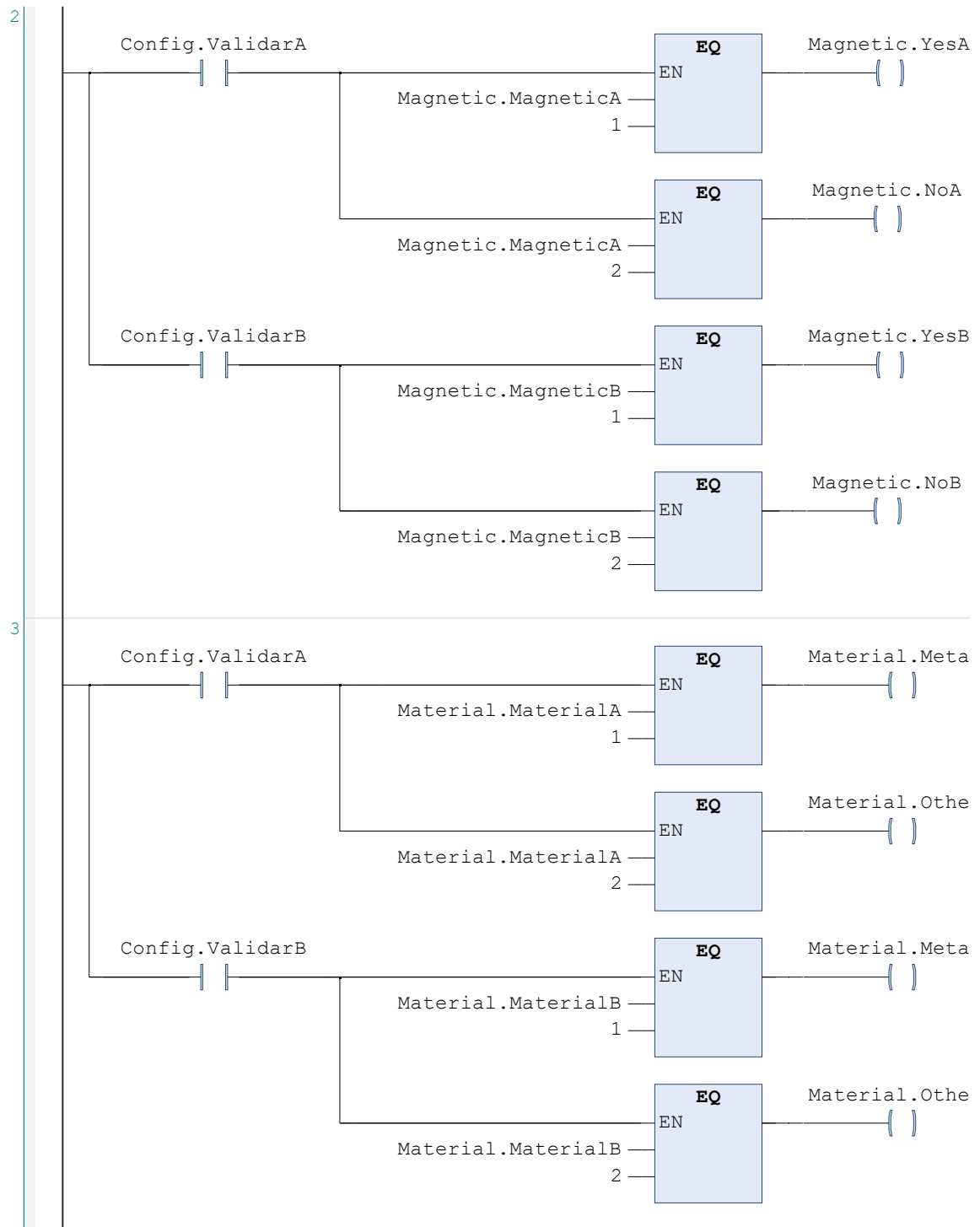

—
lA

rA

lB

rB

—

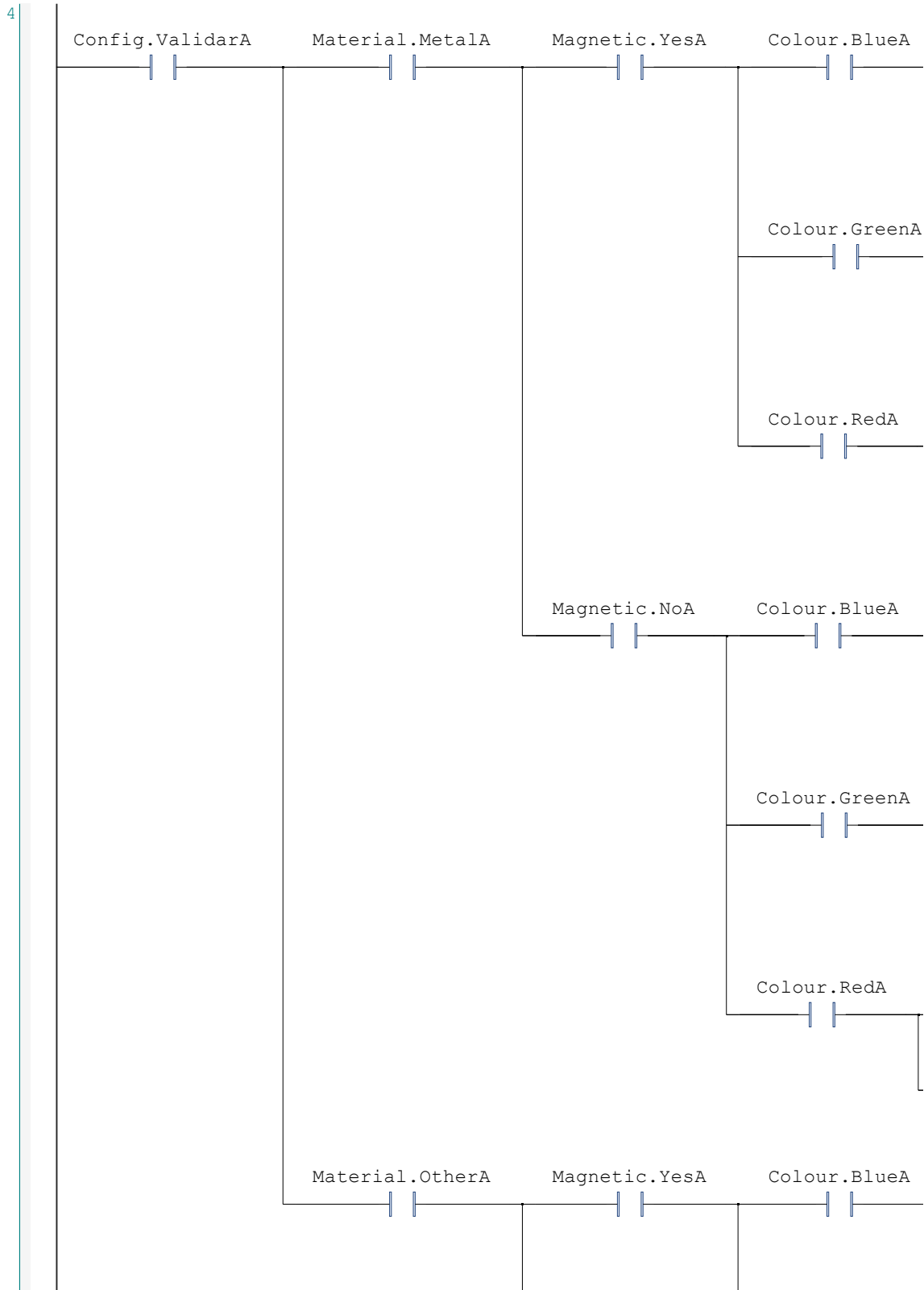

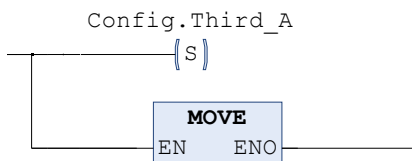
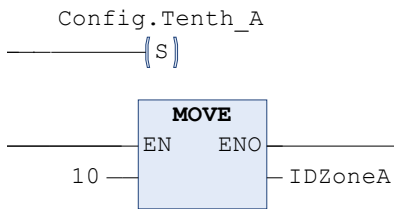
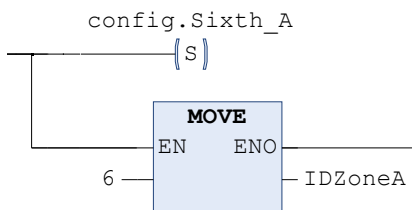
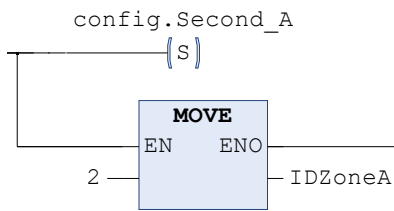
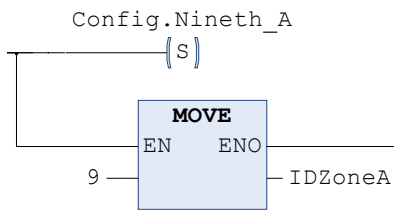
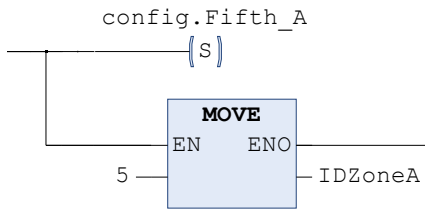
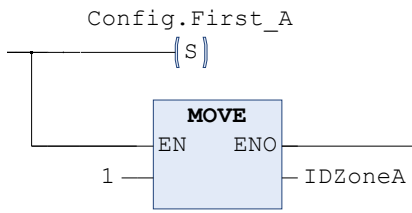

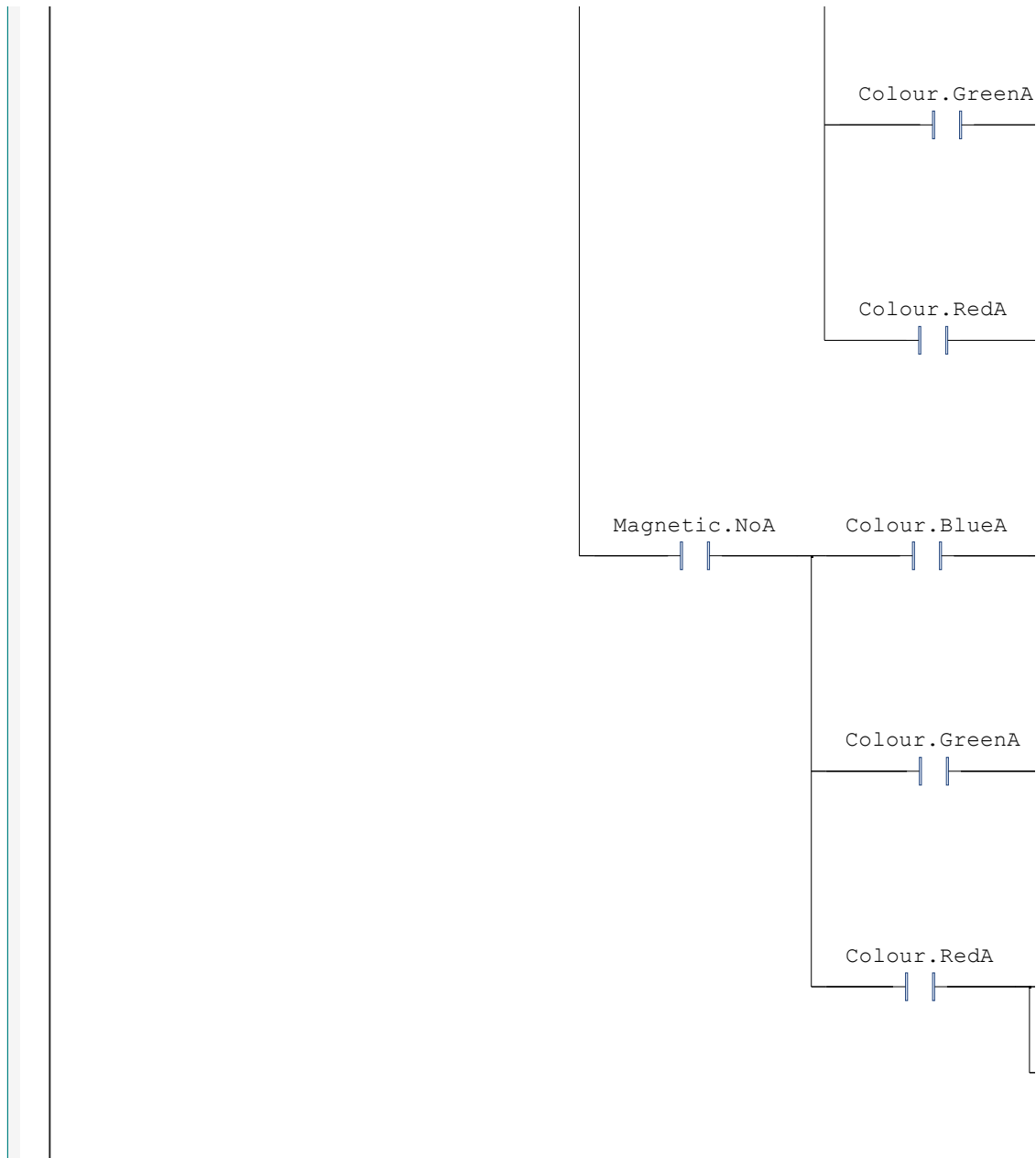

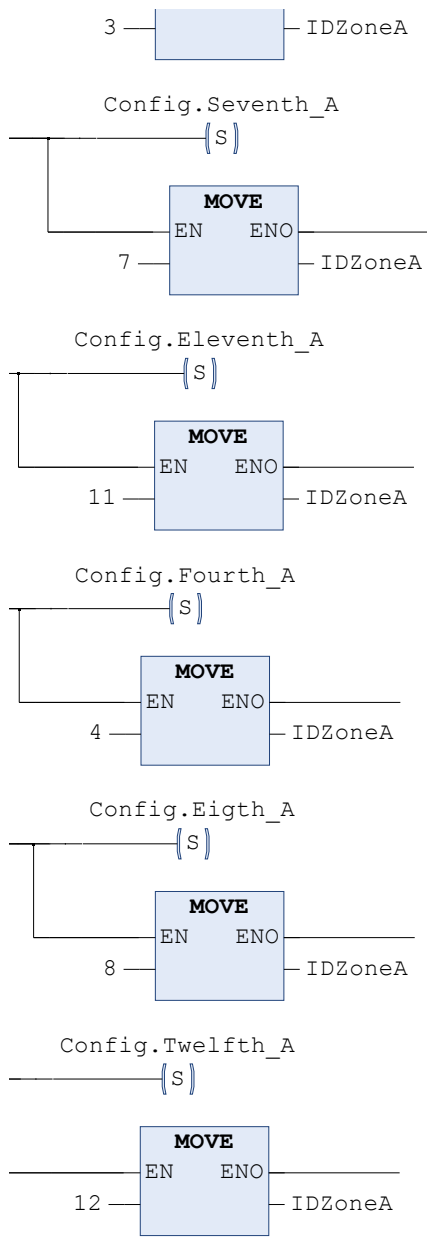

POU: _5_Configuration

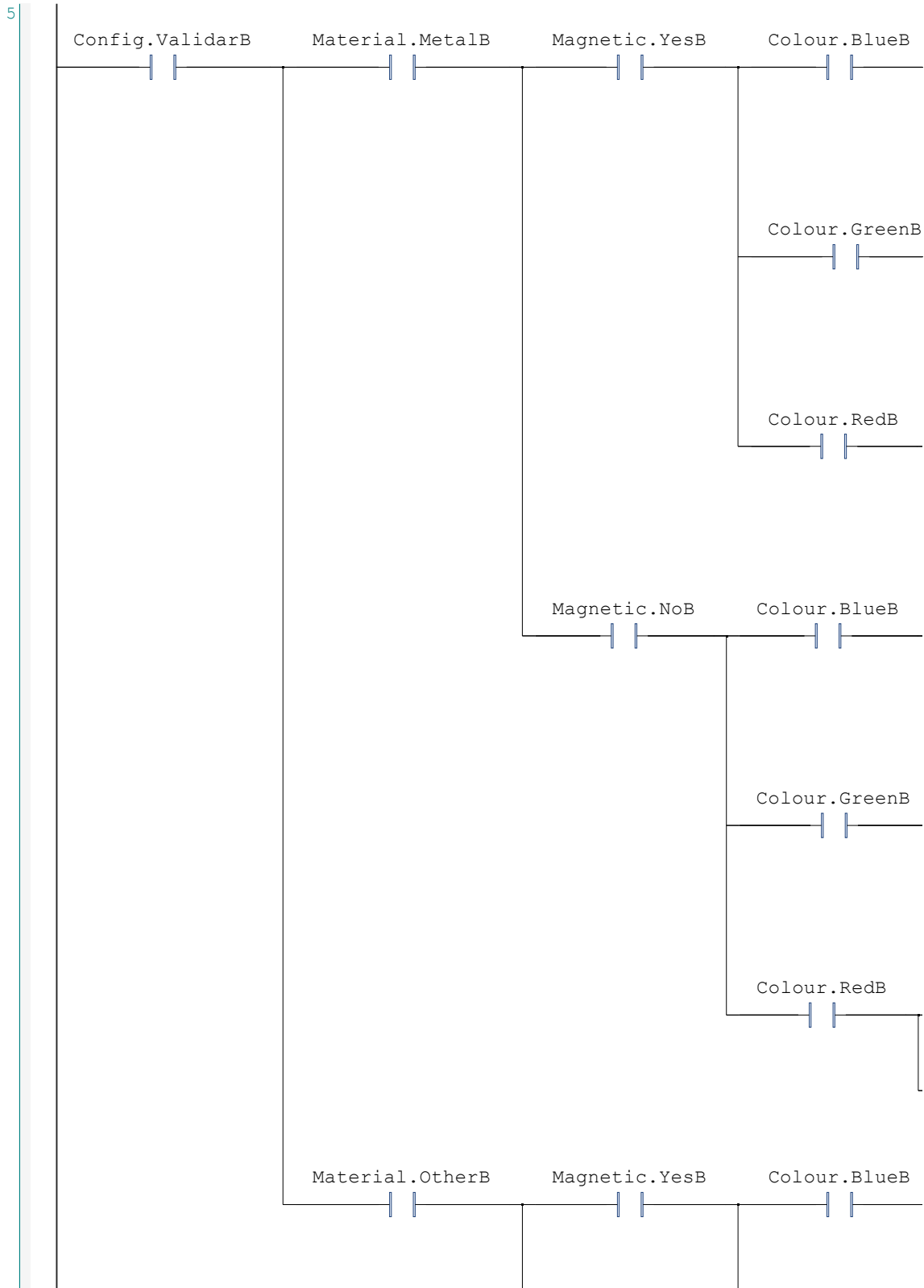

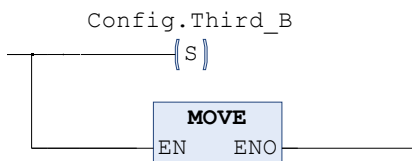
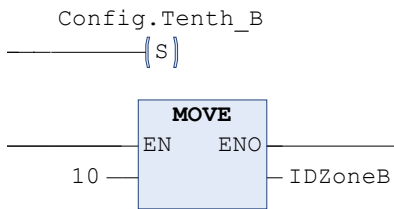
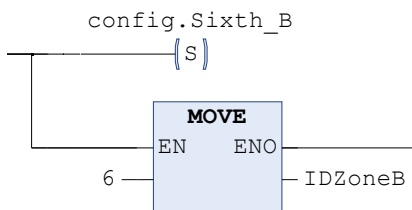
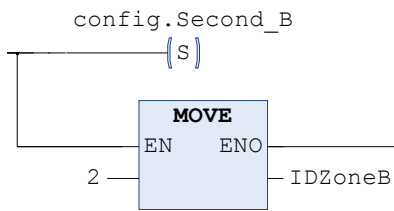
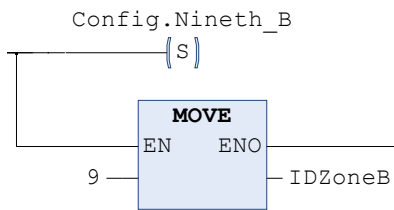
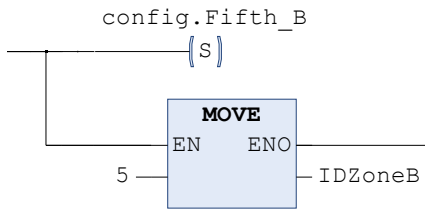
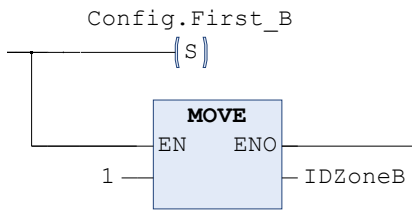

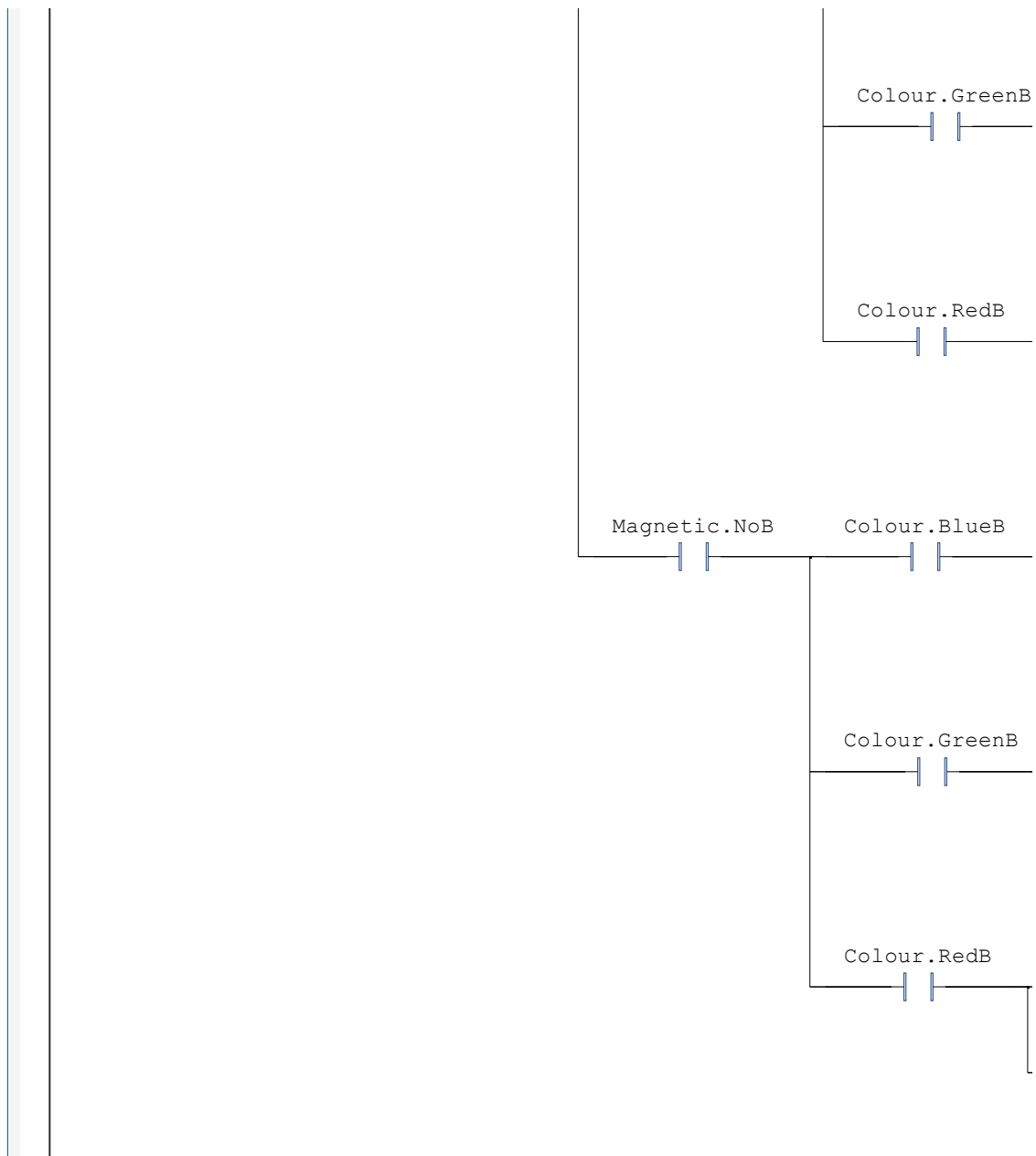

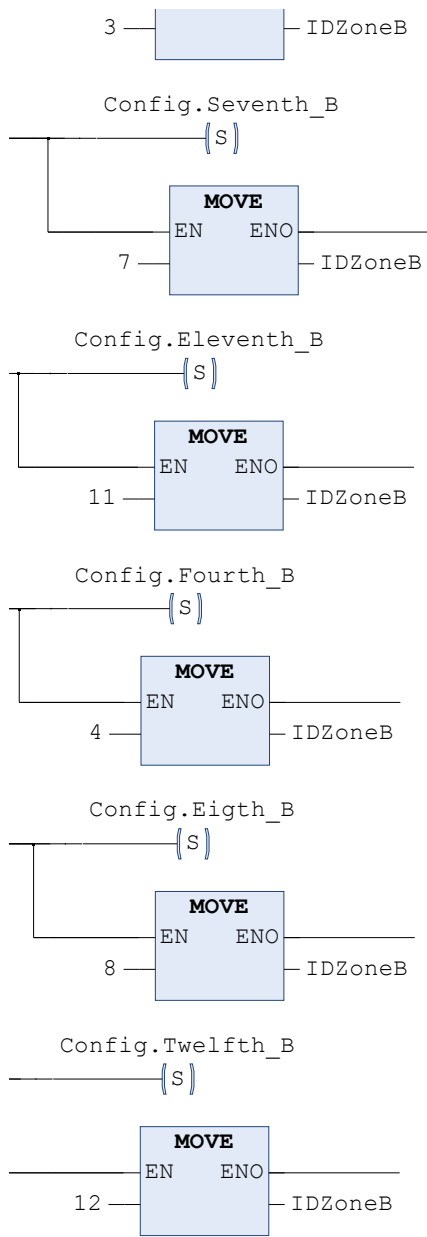





POU: _5_Configuration

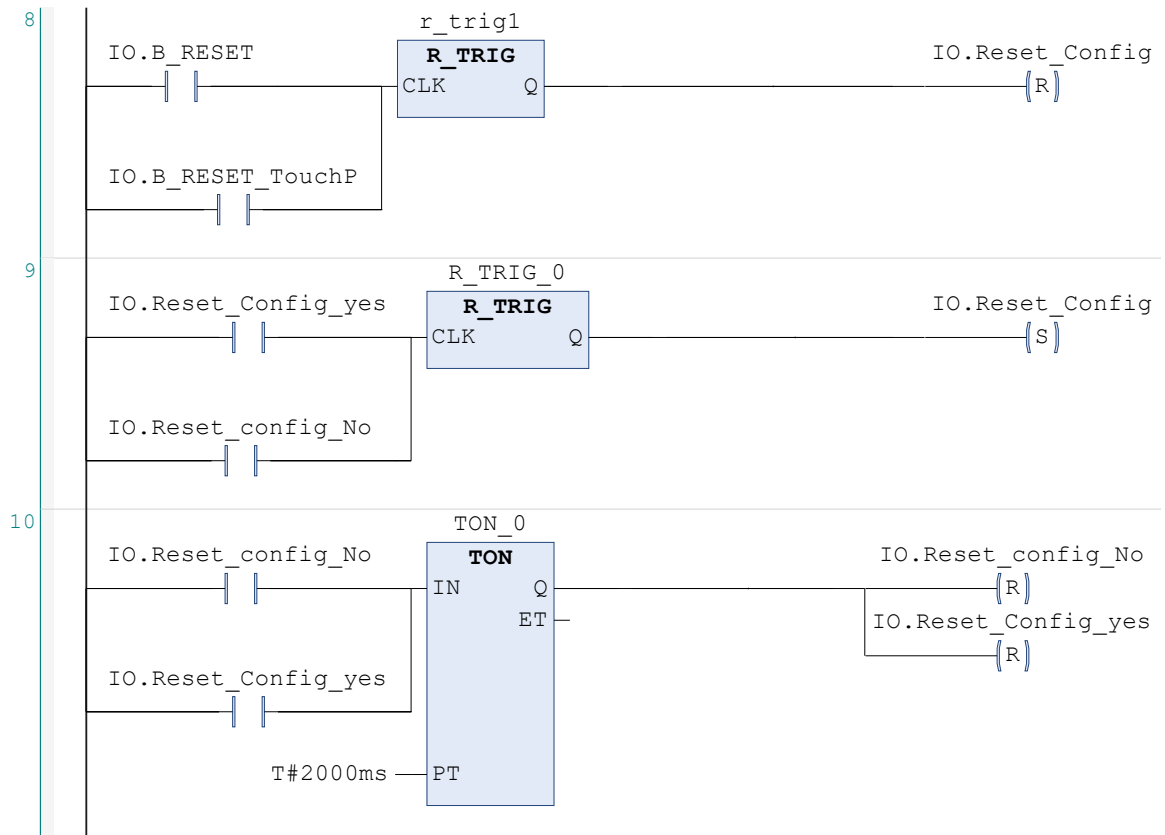

11

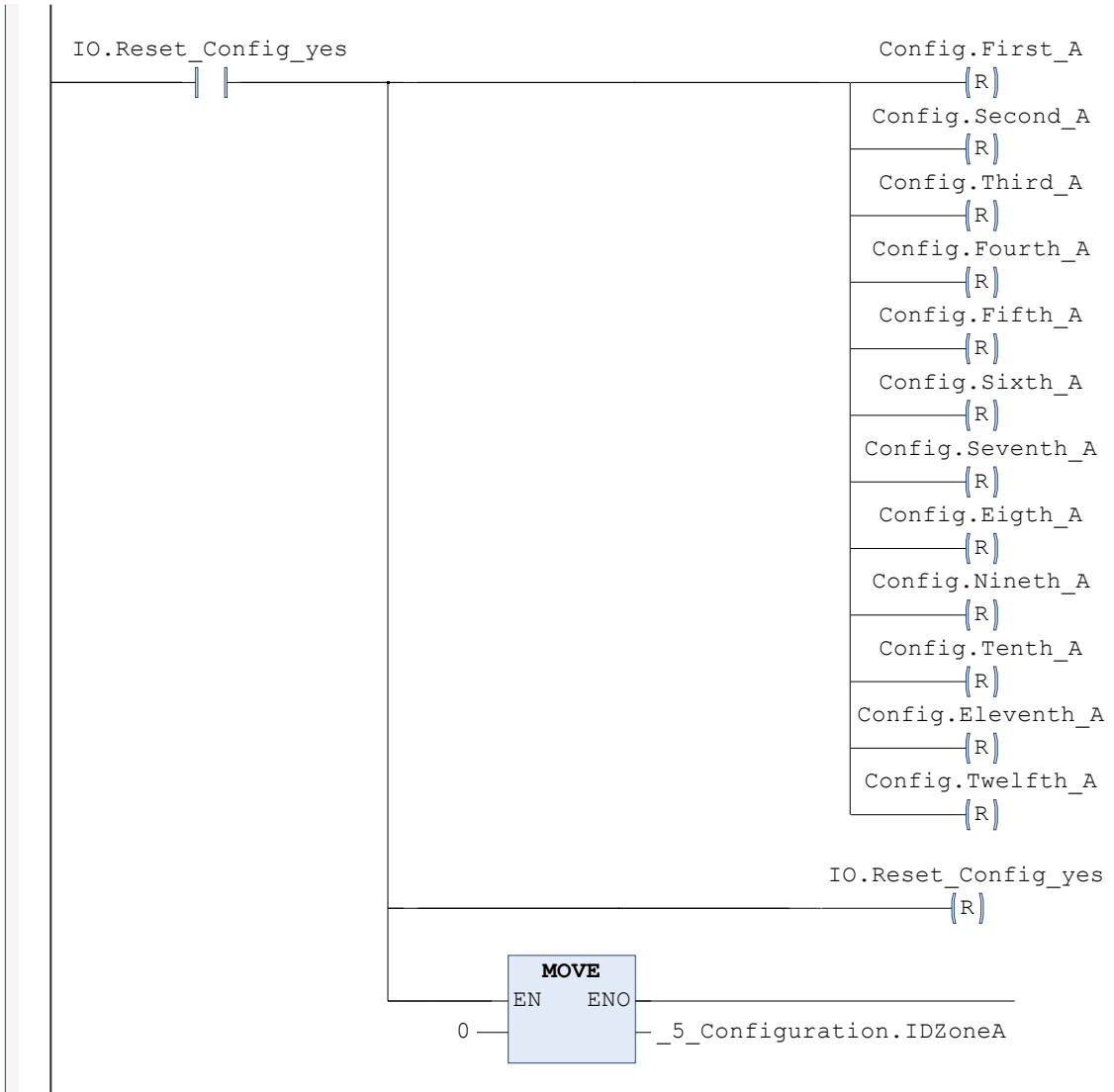

12

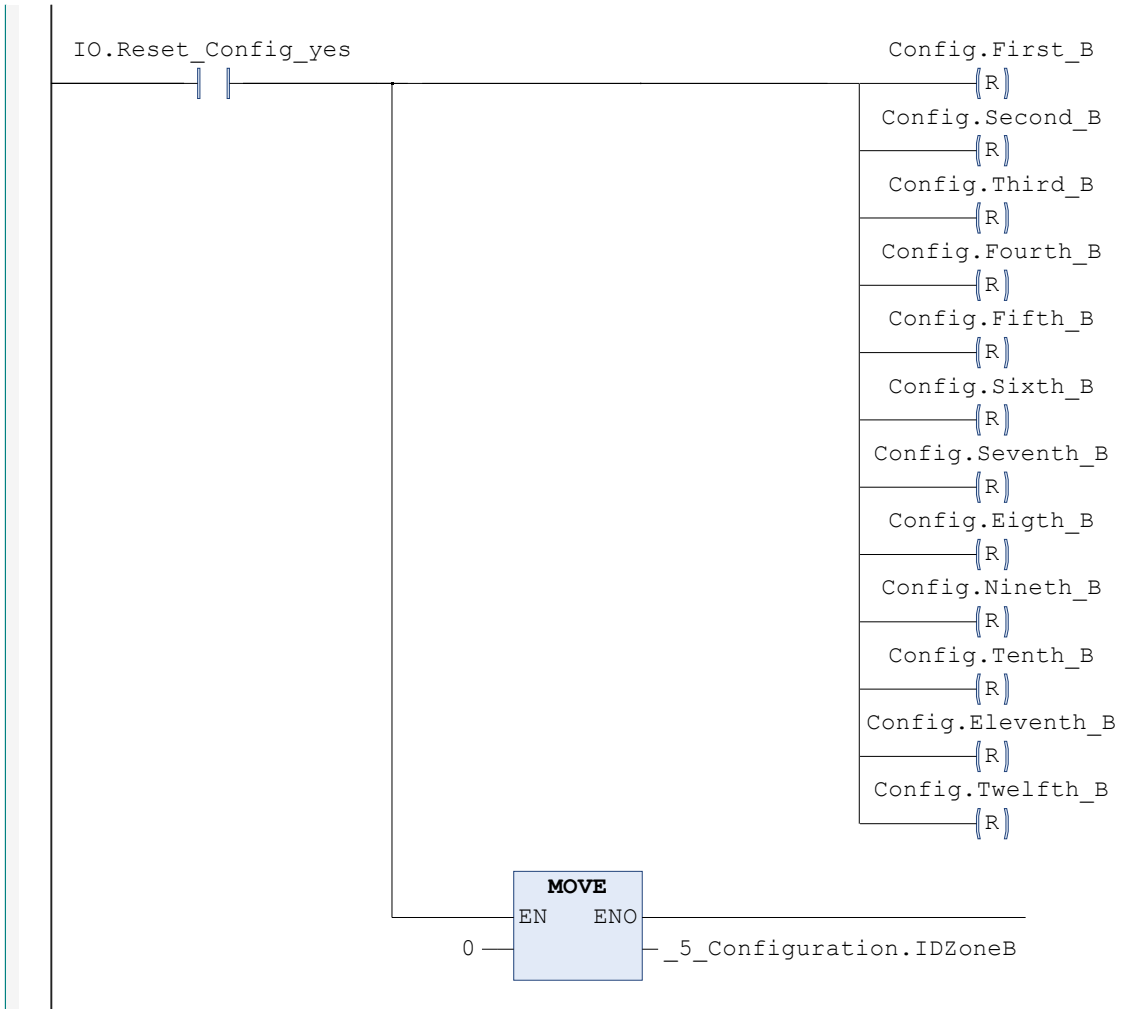



```
1  PROGRAM _6_Cycle
2  VAR
3      All_Ok : BOOL ;
4      C_NPieces_IN : CTU ;
5      Home_Axix_SM1 : MC_Home ;
6      Reset1 : BOOL ;
7      SinRobot : BOOL ;
8      Value_A : INT ;
9      Value_B : INT ;
10     TON_2 : TON ;
11     Eliminate_Piece : BOOL ;
12     Bridgel : BOOL ;
13     Home_Asix_SM2 : MC_Home ;
14     Home_Axis_SM1_0 : MC_Home ;
15     Home_Axis_SM2_0 : MC_Home ;
16     TON_5 : TON ;
17     TON_6 : TON ;
18     TON_7 : TON ;
19     TON_8 : TON ;
20     TON_9 : TON ;
21     TON_10 : TON ;
22     step1 : BOOL ;
23     step2 : BOOL ;
24     step3 : BOOL ;
25     step4 : bool ;
26     step5 : BOOL ;
27     TON_11 : TON ;
28     step6 : BOOL ;
29     step7 : BOOL ;
30     JOG_DC_Motor2_B : MC_Jog ;
31     JOG_DC_Motor2_F : MC_Jog ;
32     Step8 : BOOL ;
33     TON_12 : TON ;
34     Aux1 : BOOL ;
35     IDState : INT ;
36     result0 : REAL ;
37     result1 : REAL ;
38     result2 : REAL ;
39     Position : REAL ;
40     result3 : REAL ;
41     result4 : REAL ;
42     result5 : REAL ;
43     Result6 : REAL ;
44     TON_14 : TON ;
45     TON_15 : TON ;
46     TON_16 : TON ;
47     TON_18 : TON ;
48     MC_ReadActualPosition_SM1 : MC_ReadActualPosition ;
49     MC_ReadActualPosition_SM2 : MC_ReadActualPosition ;
50     R_TRIG_11 : R_TRIG ;
51     MC_MoveAbsolute_1 : MC_MoveAbsolute ;
52     MC_MoveAbsolute_2 : MC_MoveAbsolute ;
53     MC_MoveAbsolute_3 : MC_MoveAbsolute ;
54     MC_MoveAbsolute_4 : MC_MoveAbsolute ;
55     MC_MoveAbsolute_5 : MC_MoveAbsolute ;
56     MC_MoveAbsolute_6 : MC_MoveAbsolute ;
57     a : REAL ;
```



```

58     b : REAL ;
59     c : REAL ;
60     Steps_Vertical : REAL ;
61     R_TRIG_15 : R_TRIG ;
62     Done_R : BOOL ;
63     Aux2 : BOOL ;
64     Aux3 : BOOL ;
65     R_TRIG_16 : R_TRIG ;
66     F_TRIG_13 : F_TRIG ;
67     Aux4 : BOOL ;
68     TON_20 : TON ;
69     R_TRIG_20 : R_TRIG ;
70     TON_21 : TON ;
71     END_VAR
72

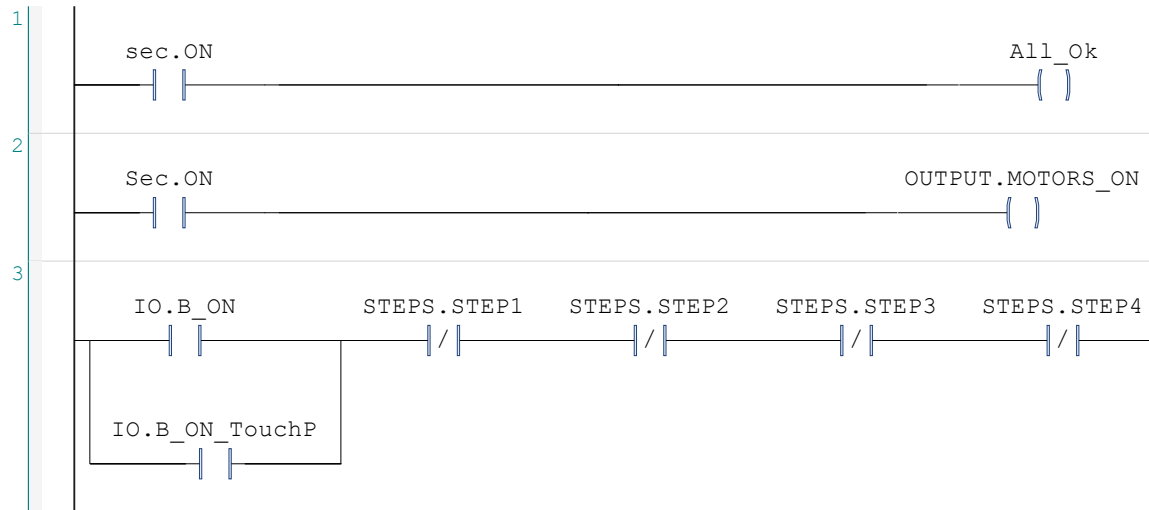
```







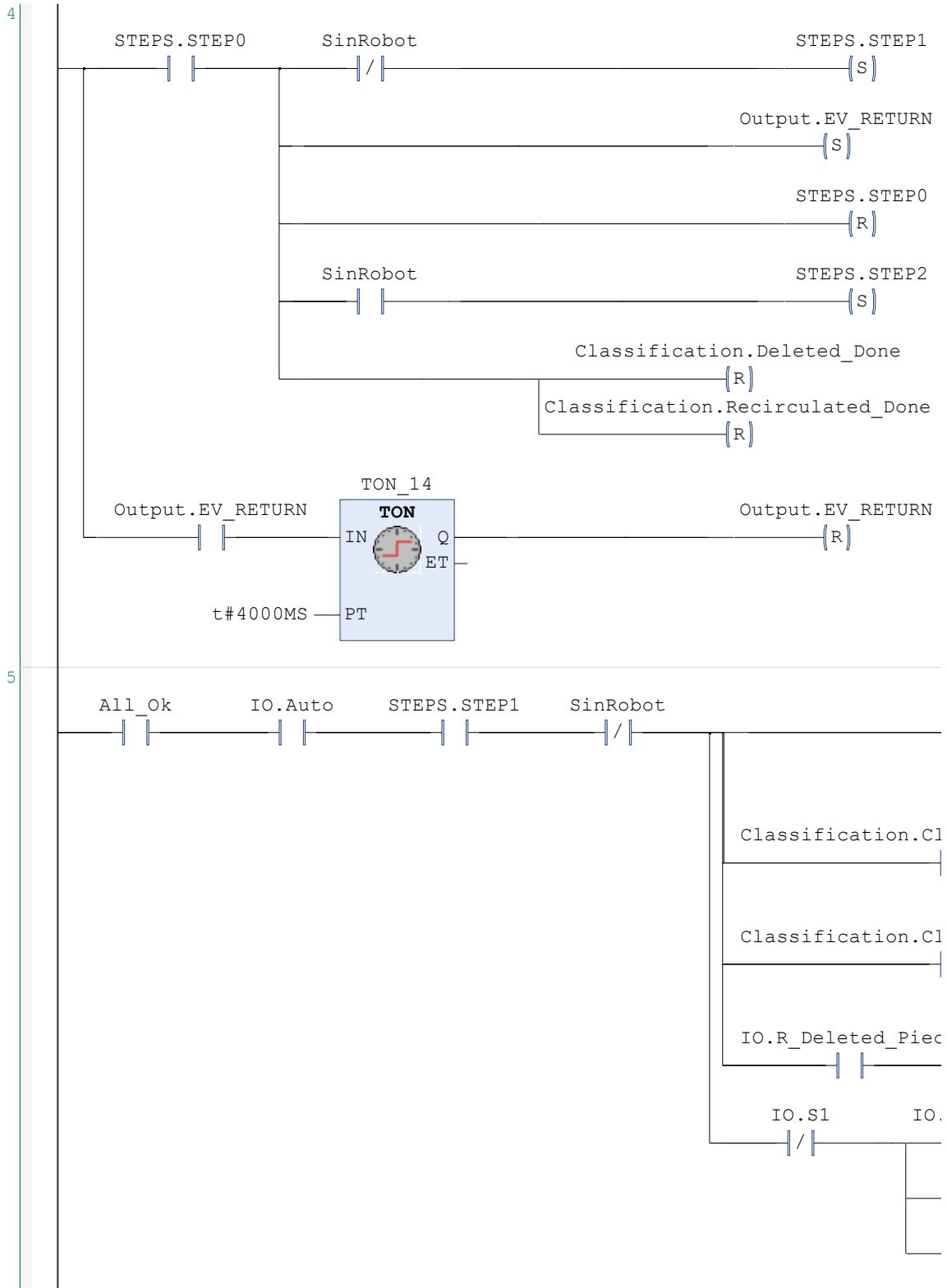

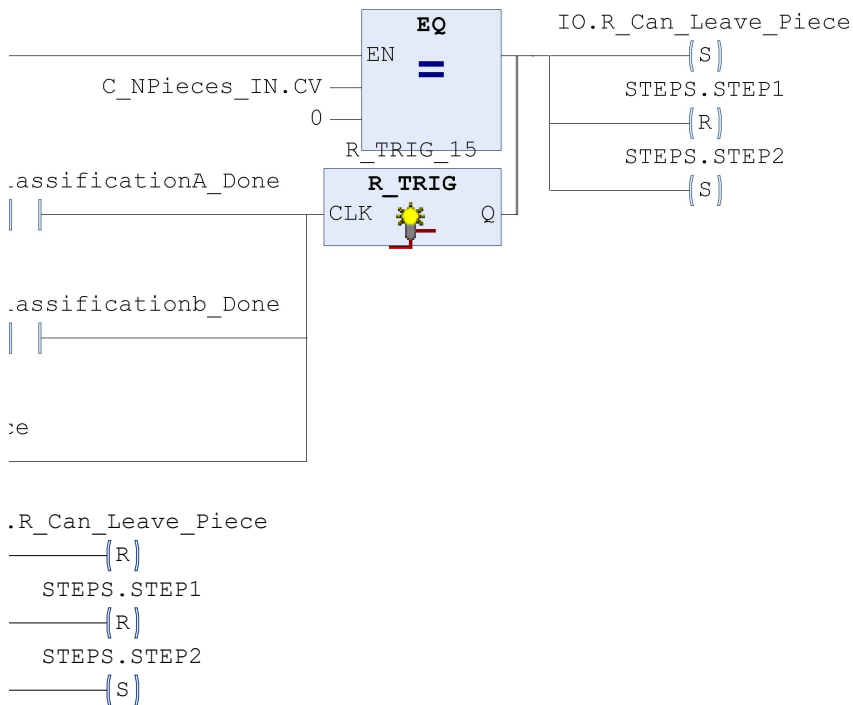

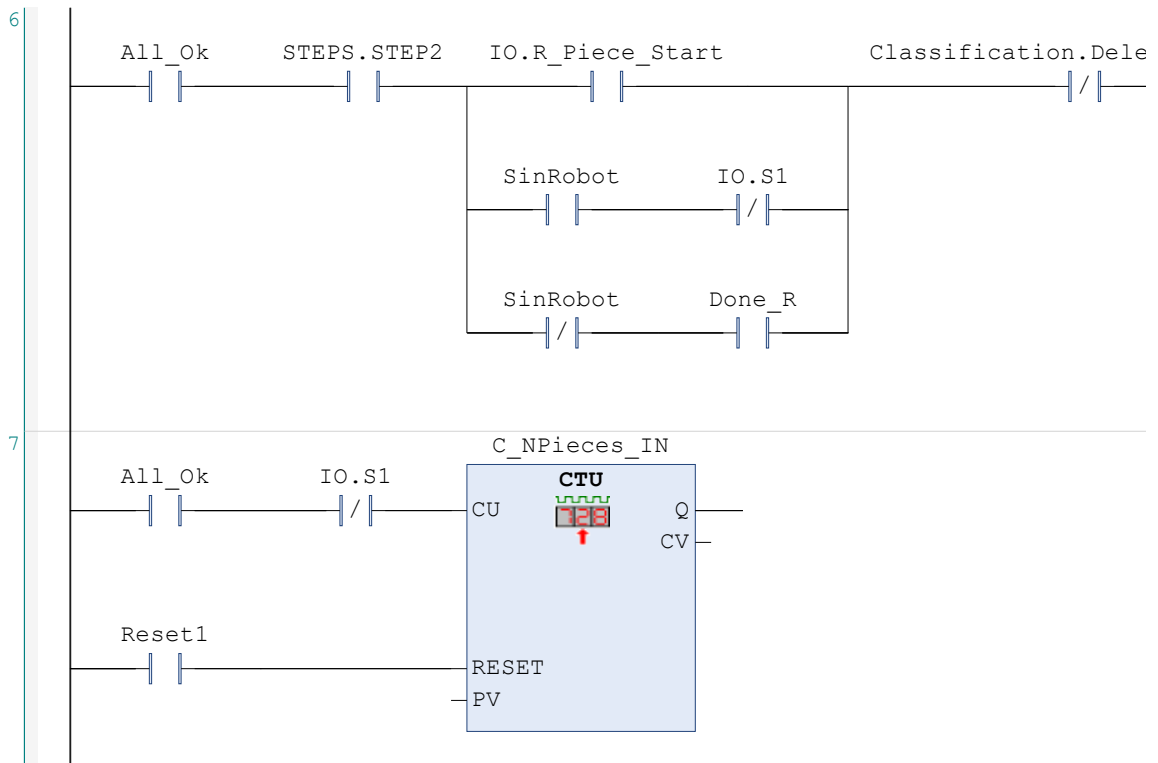

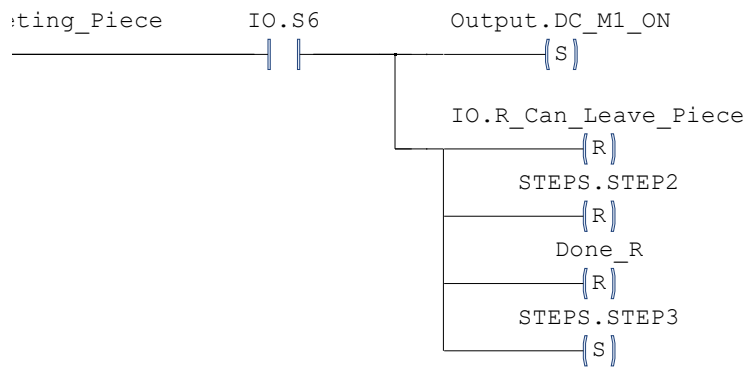

8

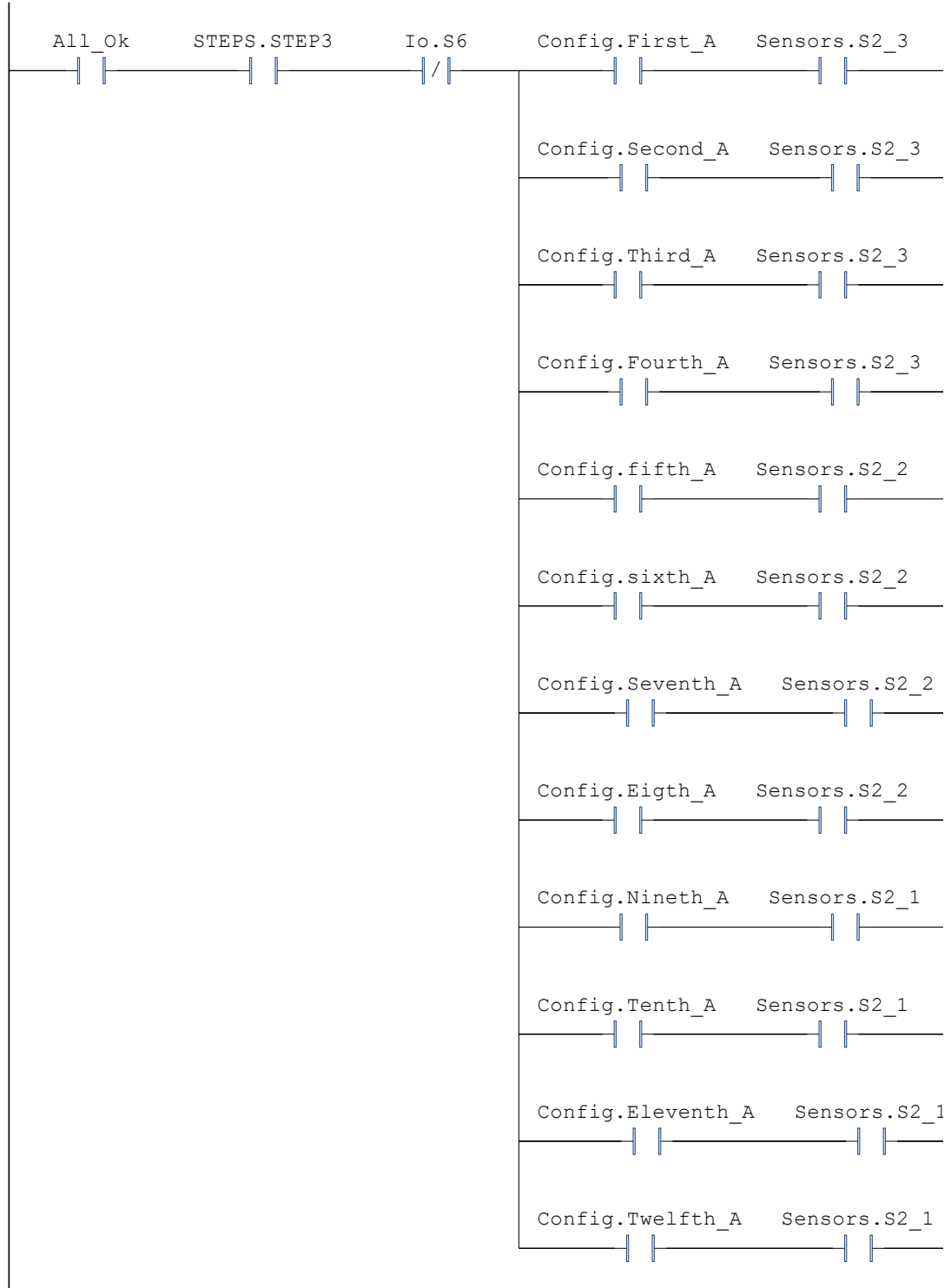

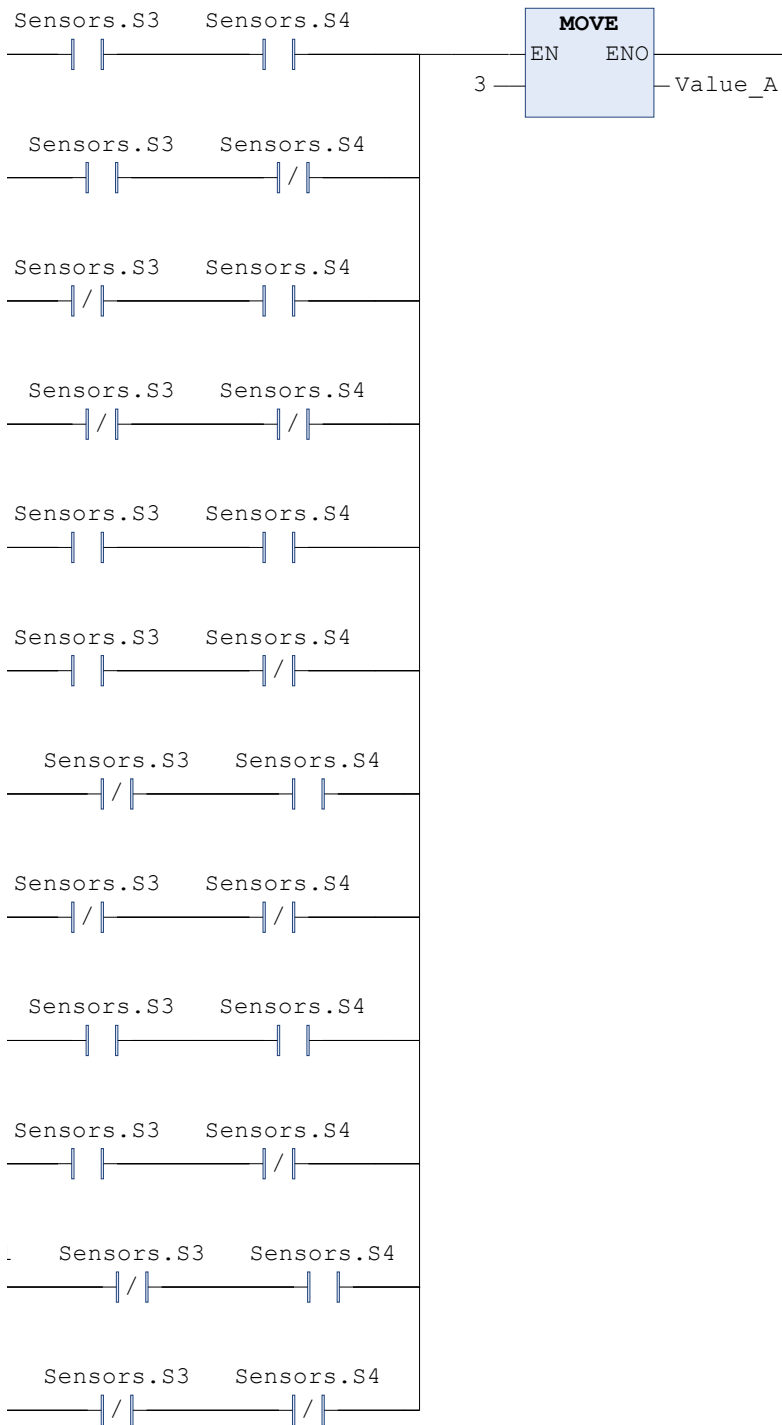

9



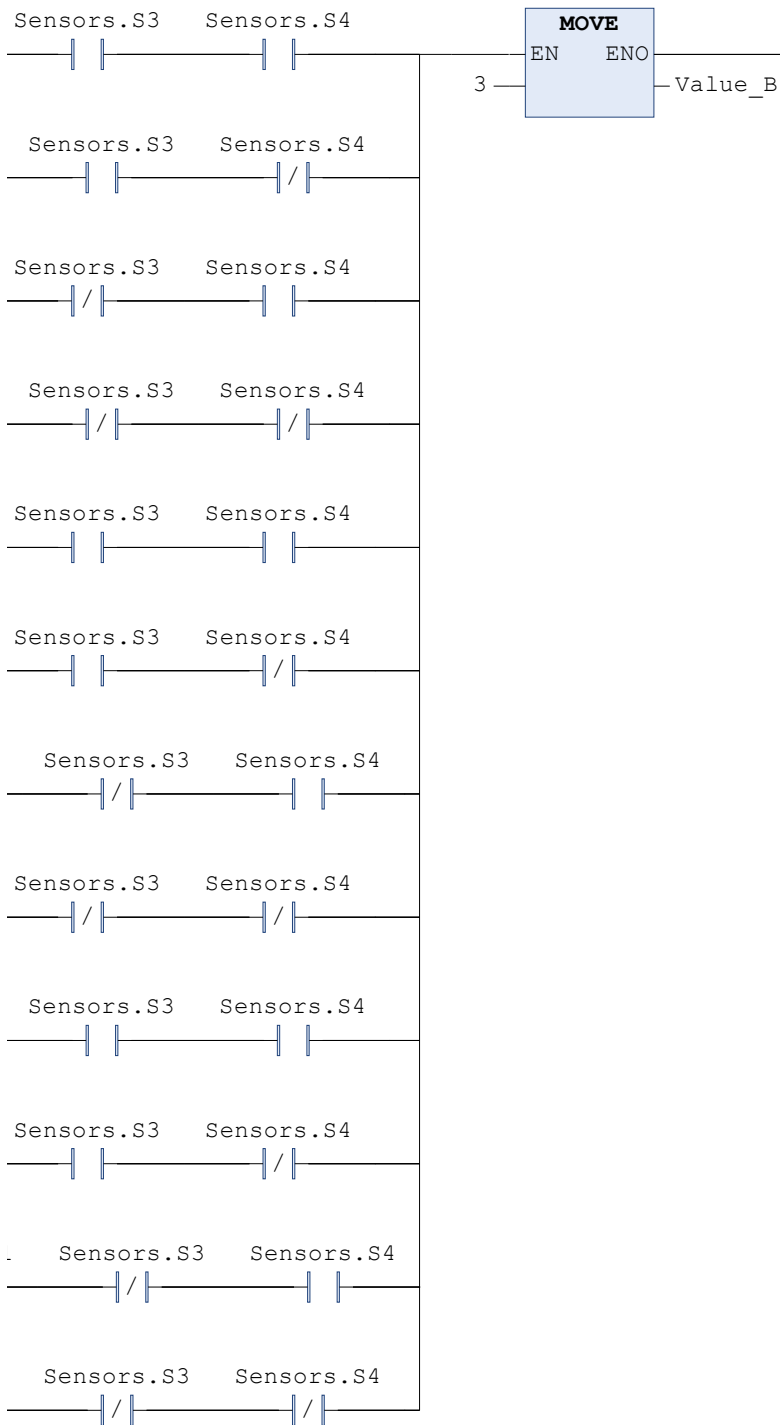

10



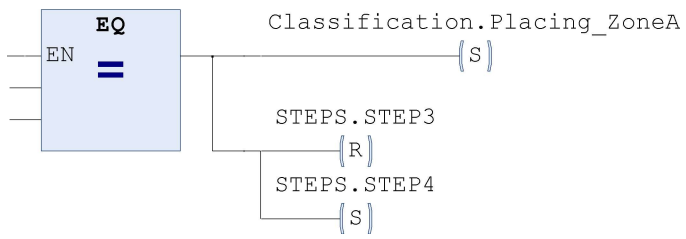

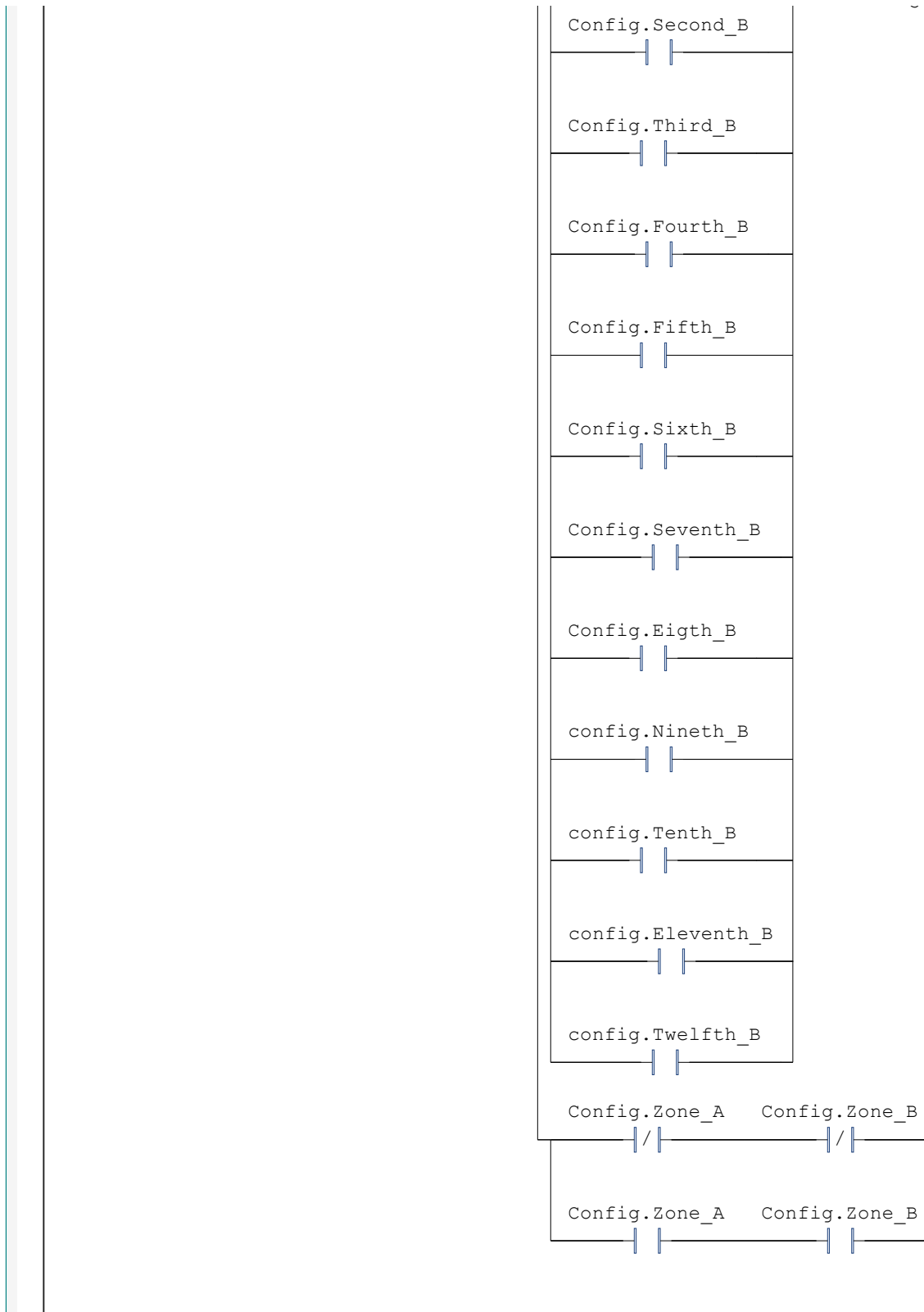

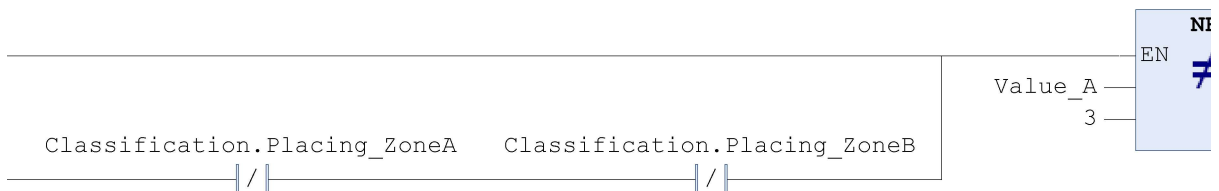
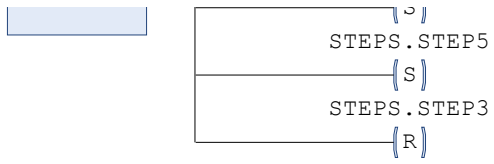

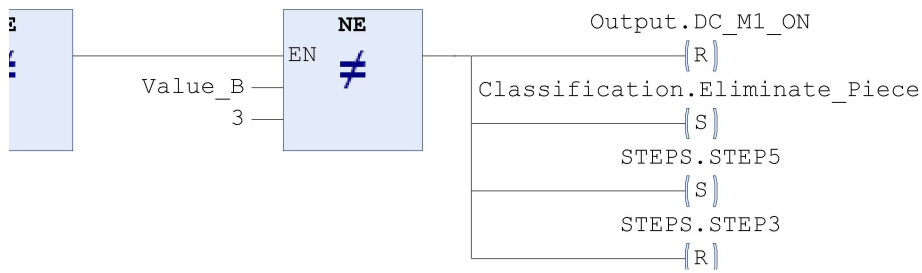

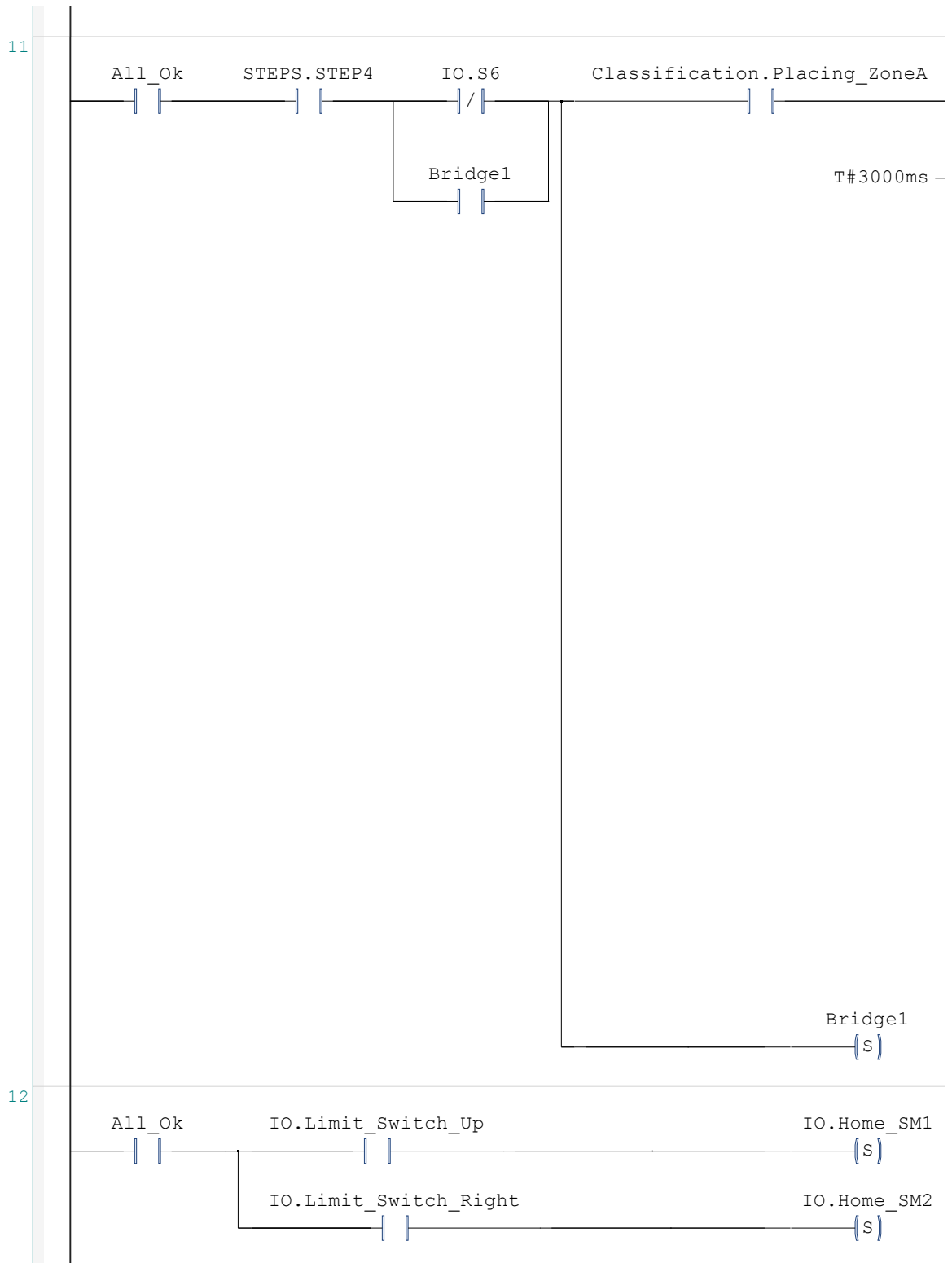

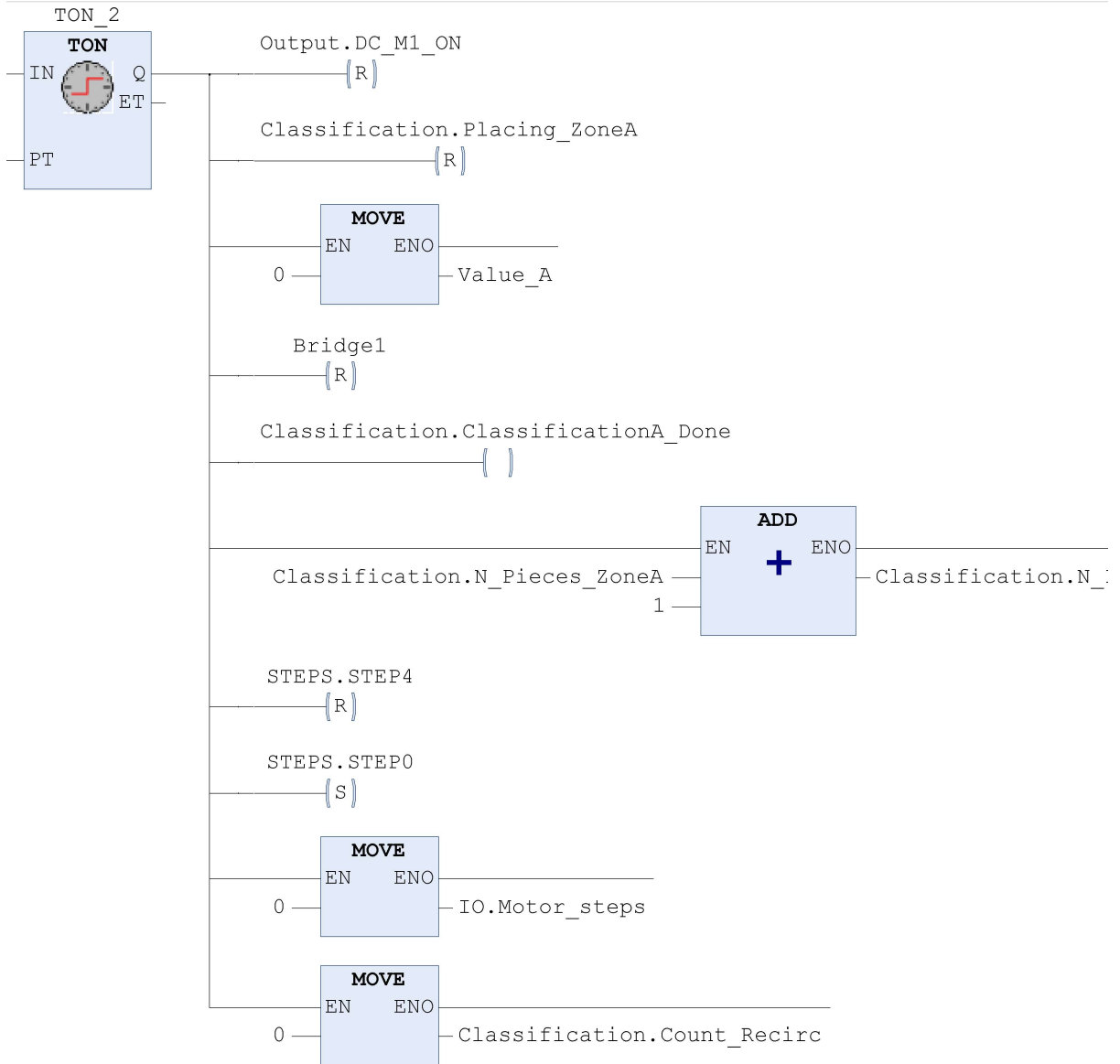

• •

Pieces_ZoneA

13

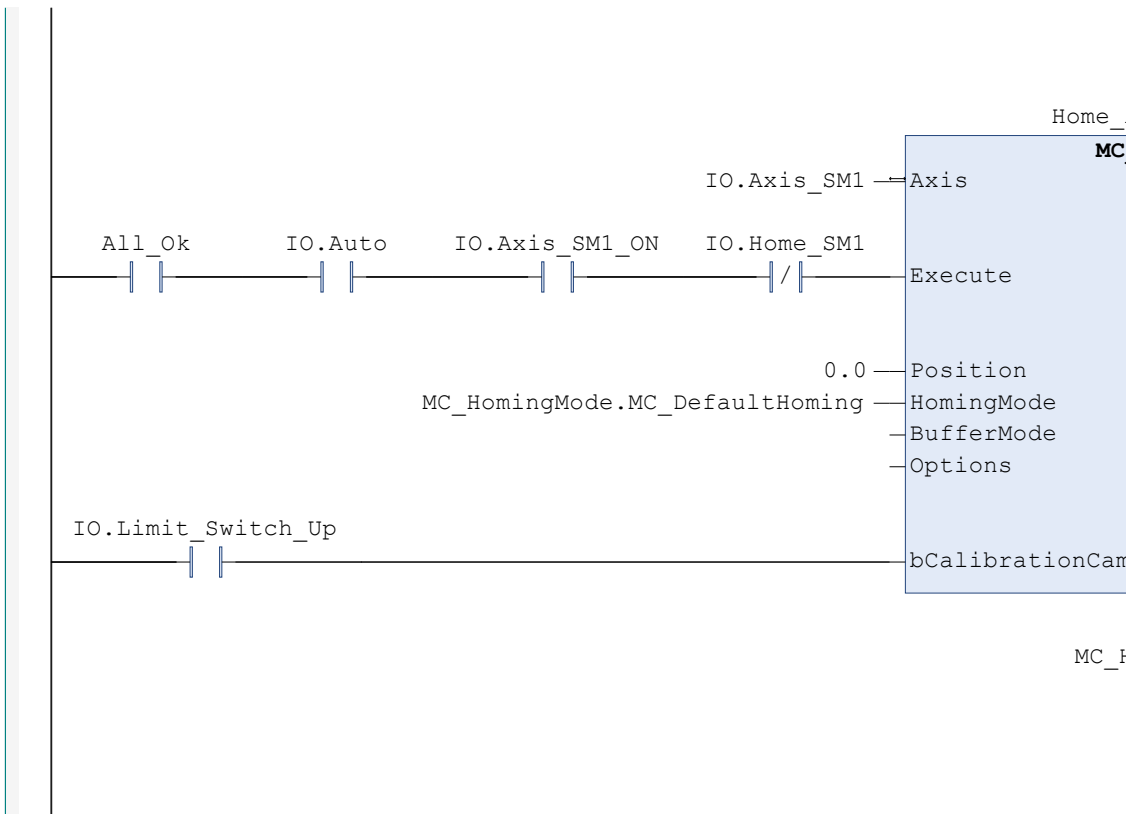

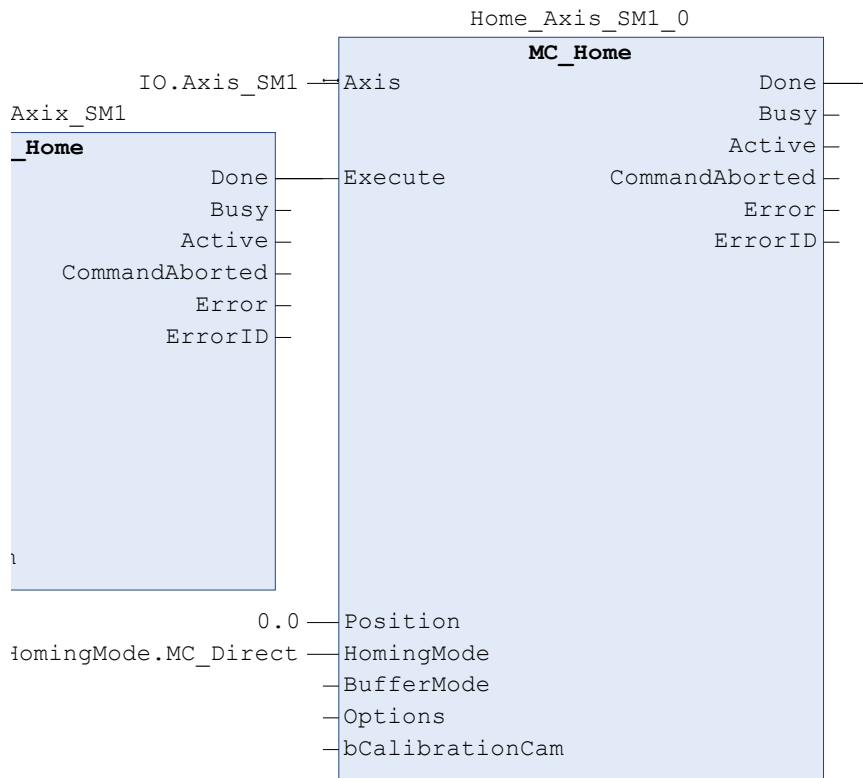

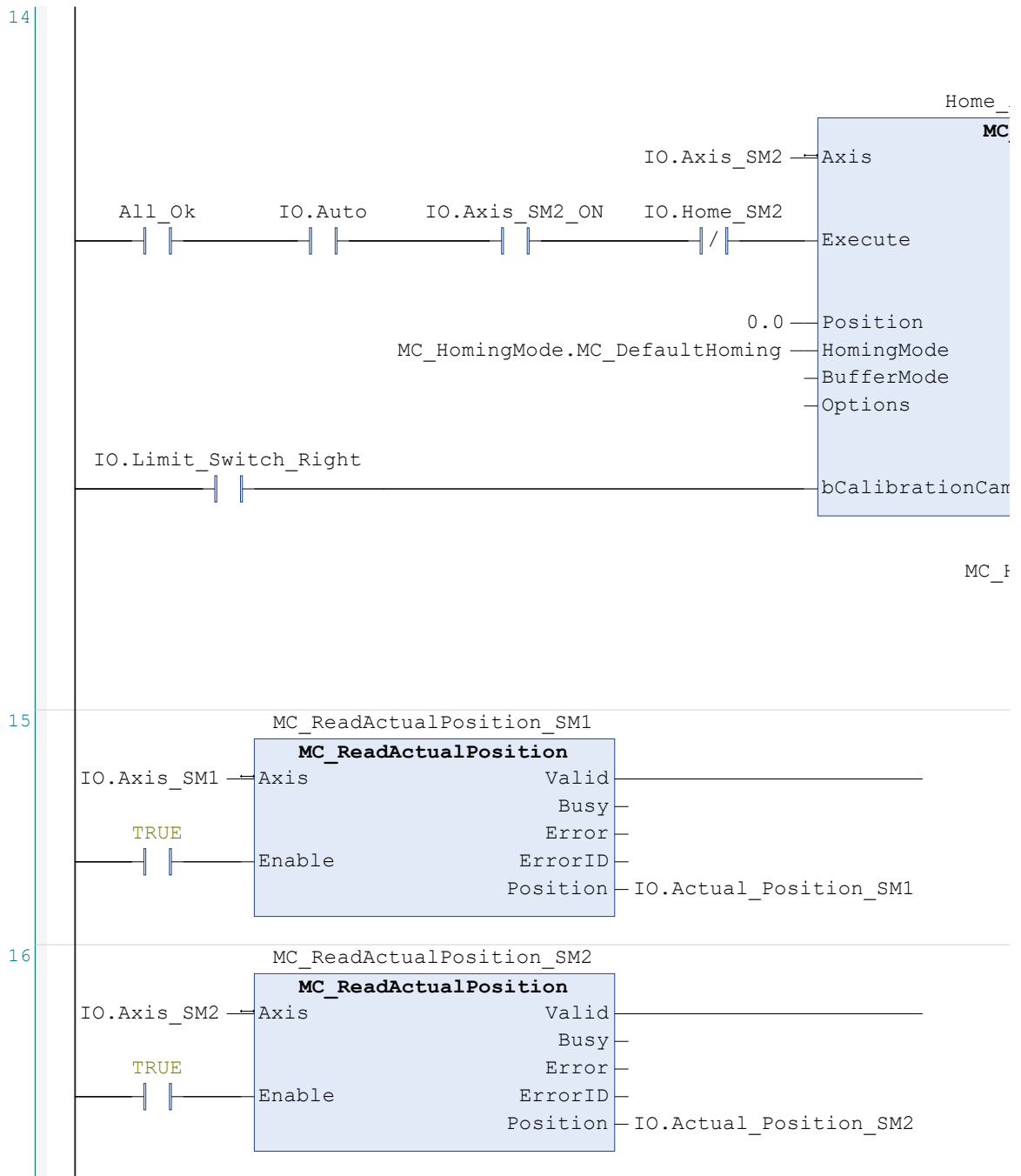

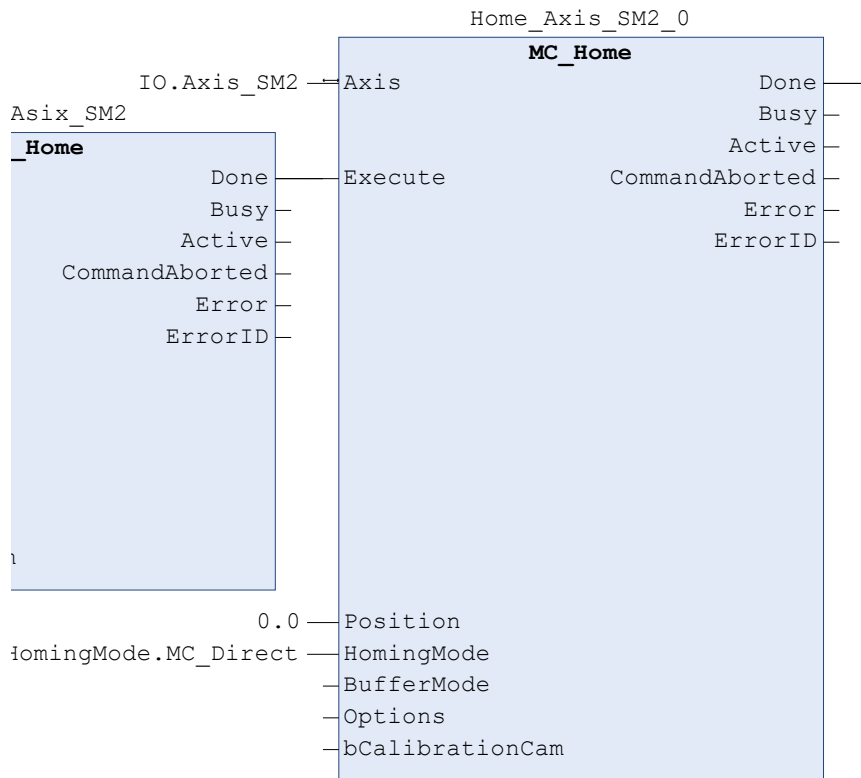

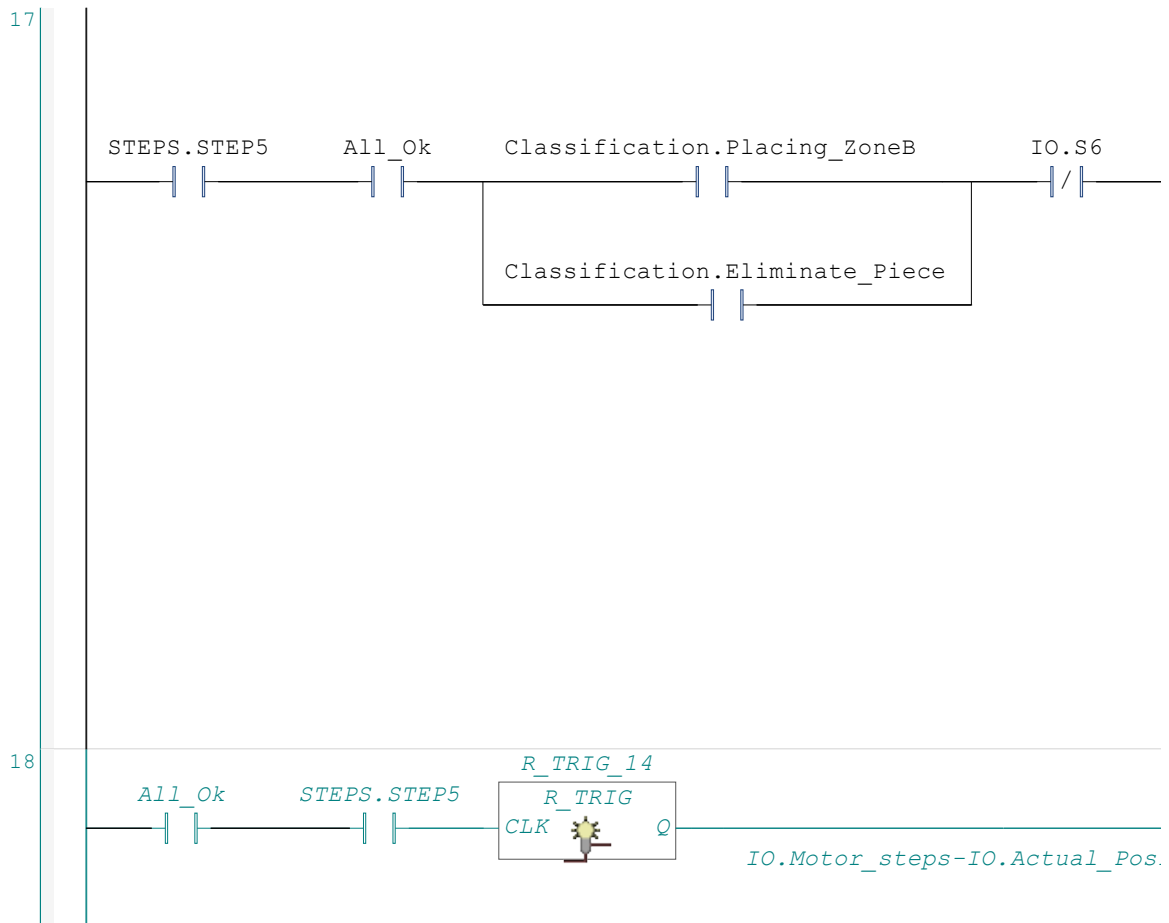

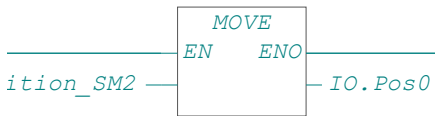
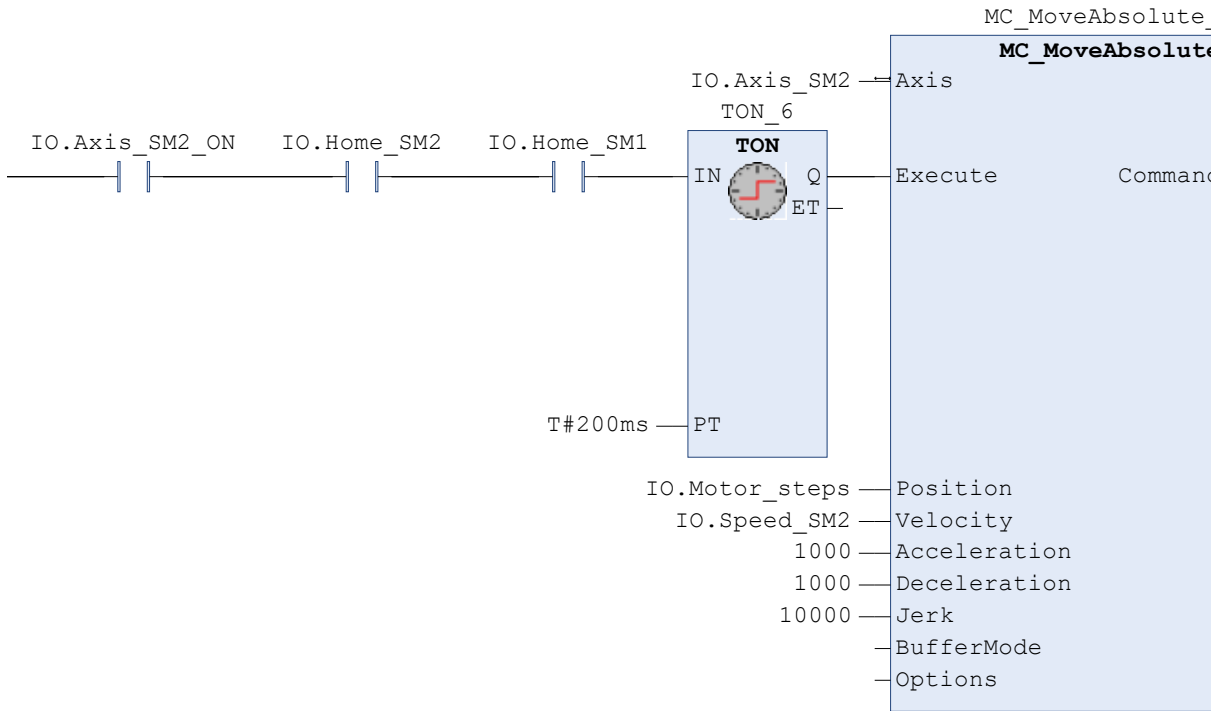

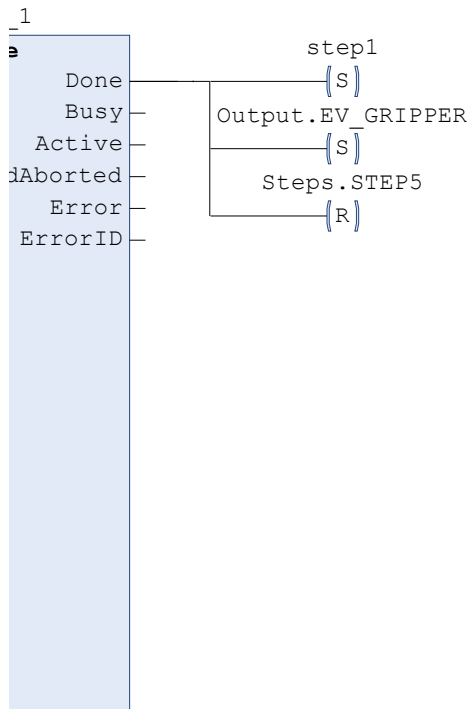

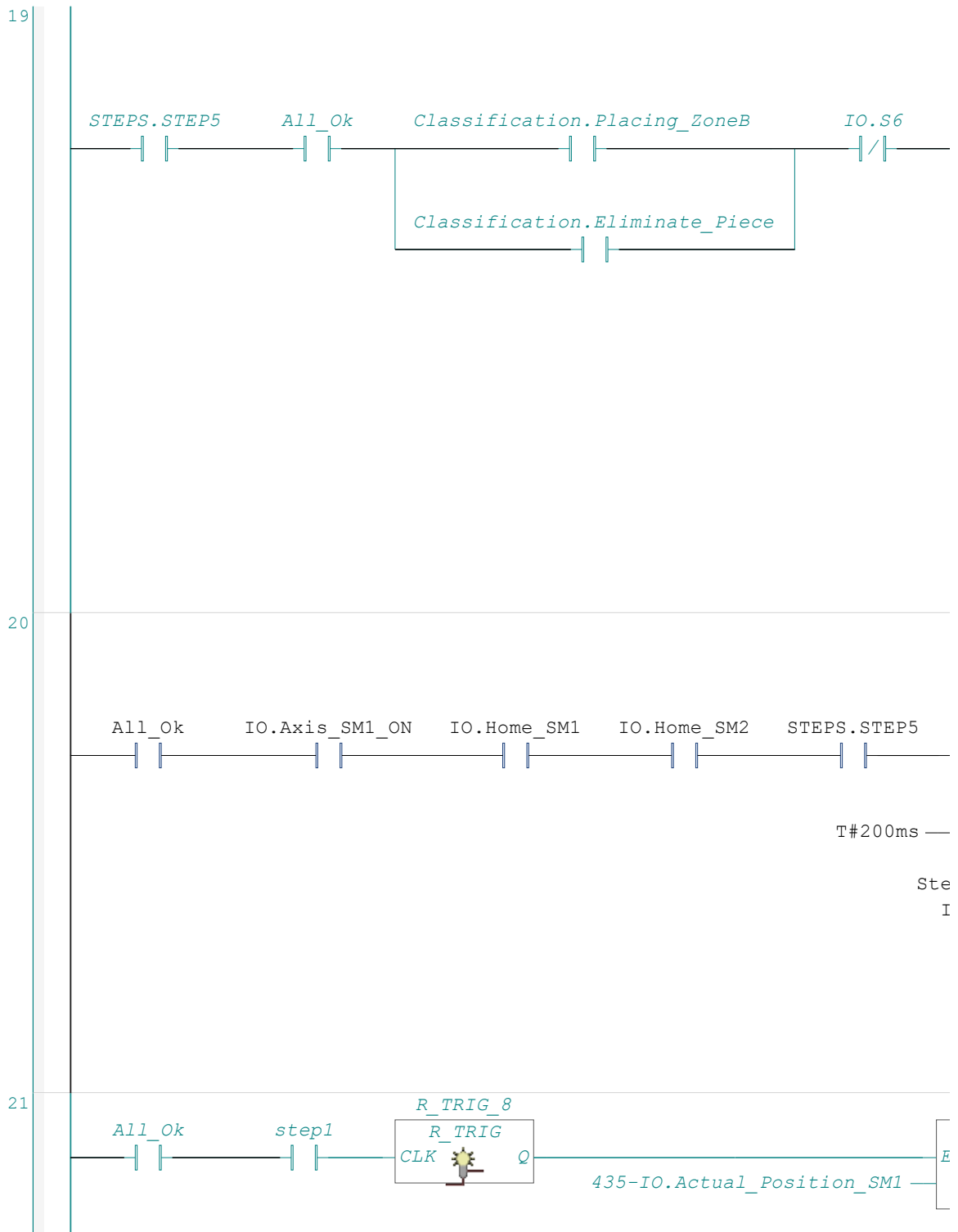

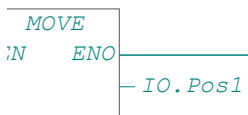
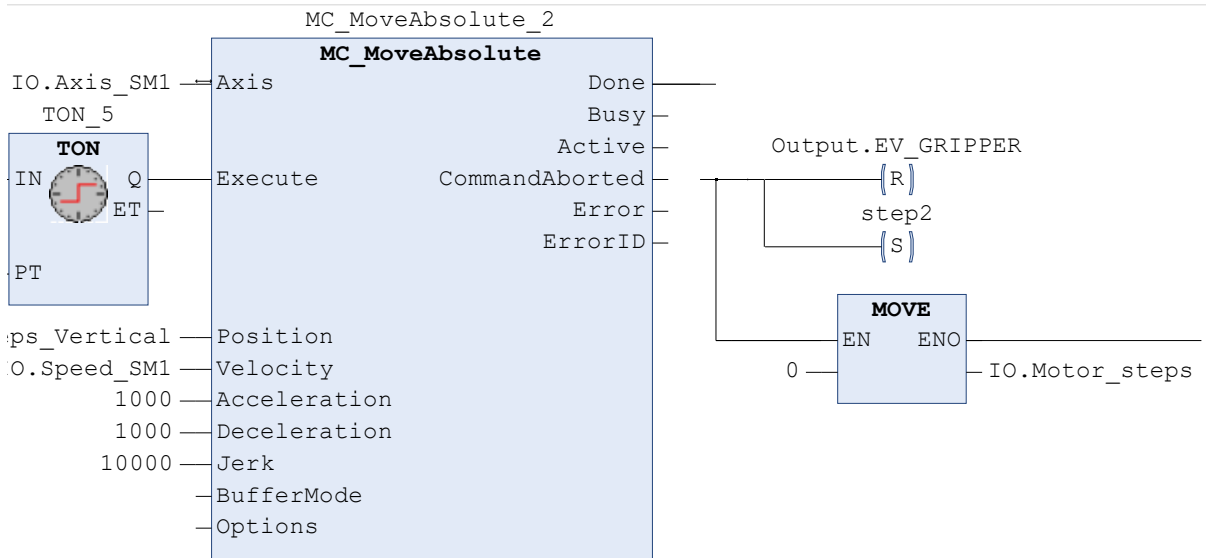
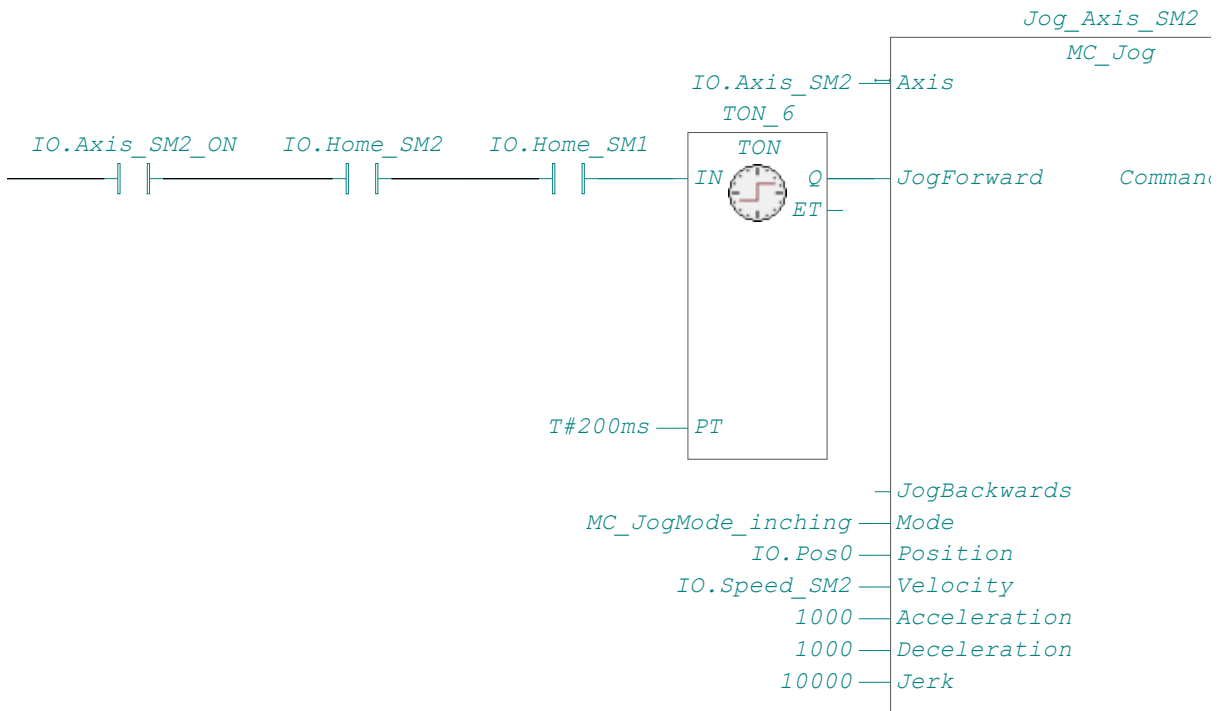

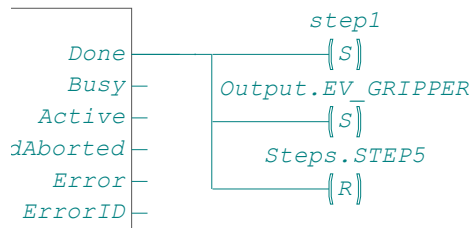

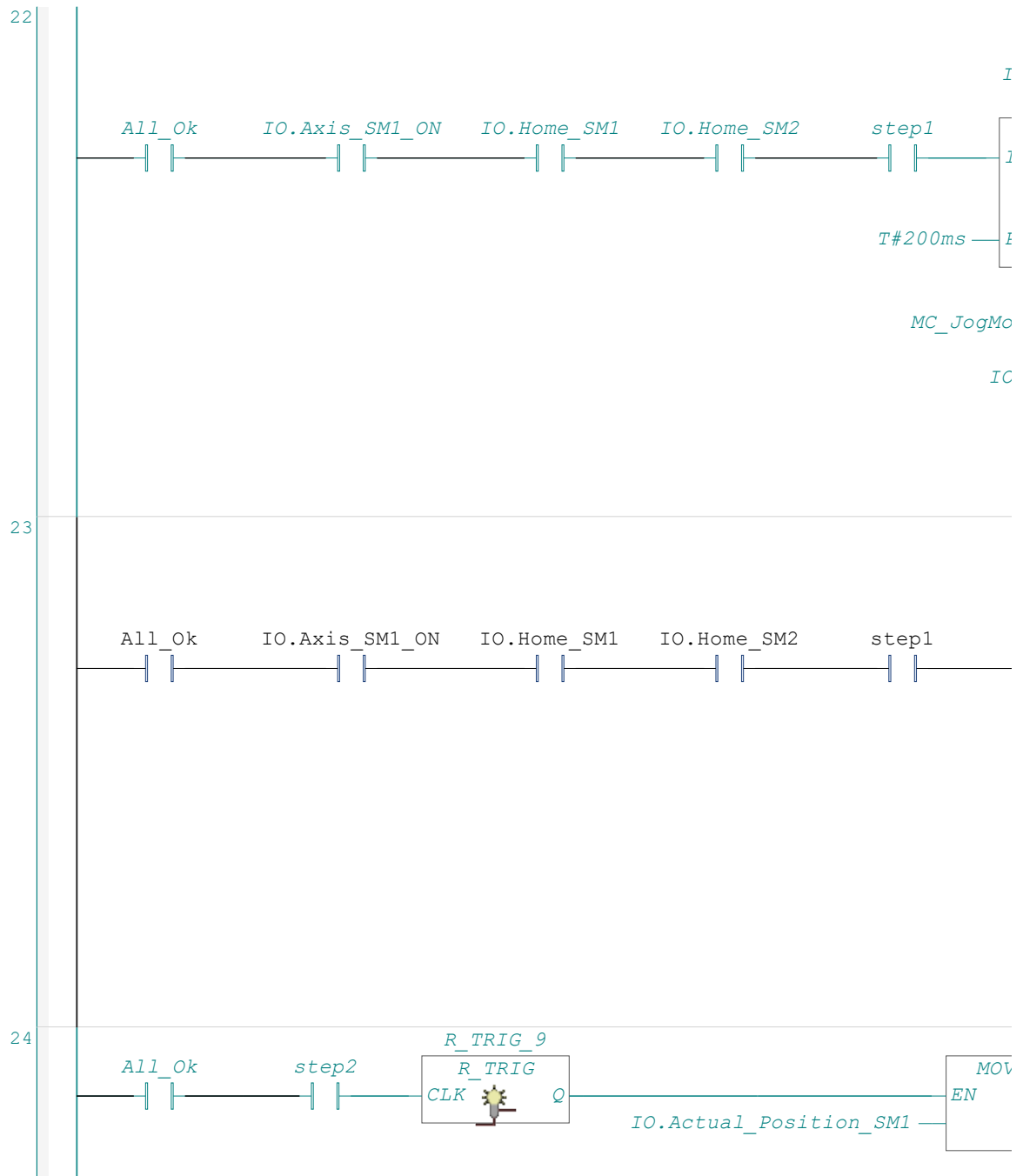

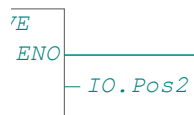
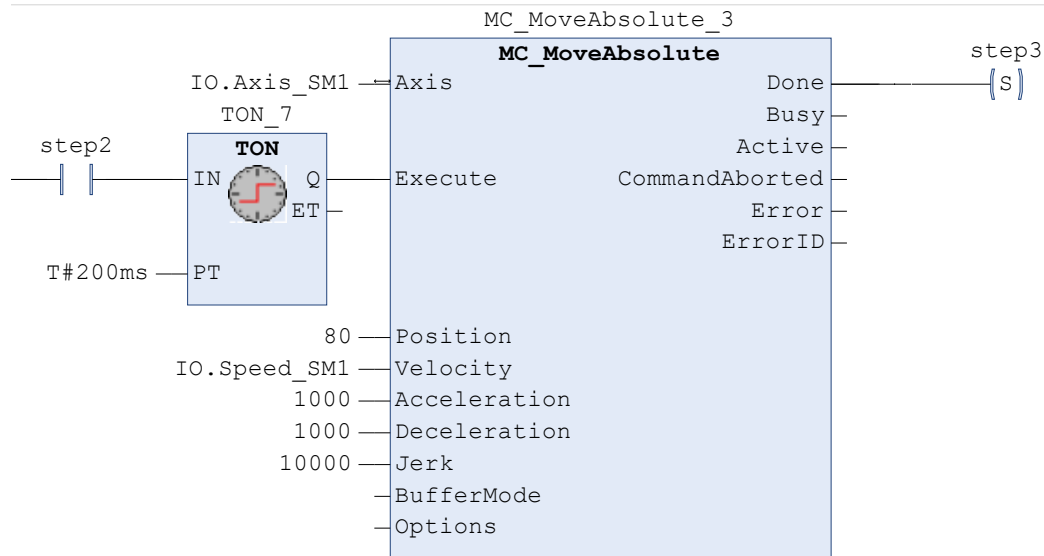
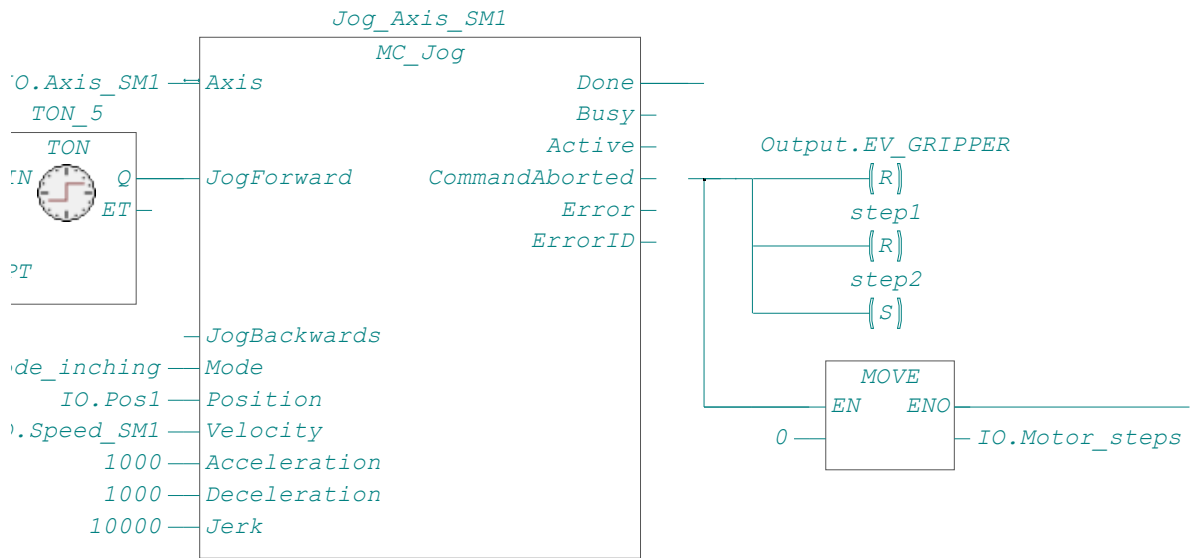

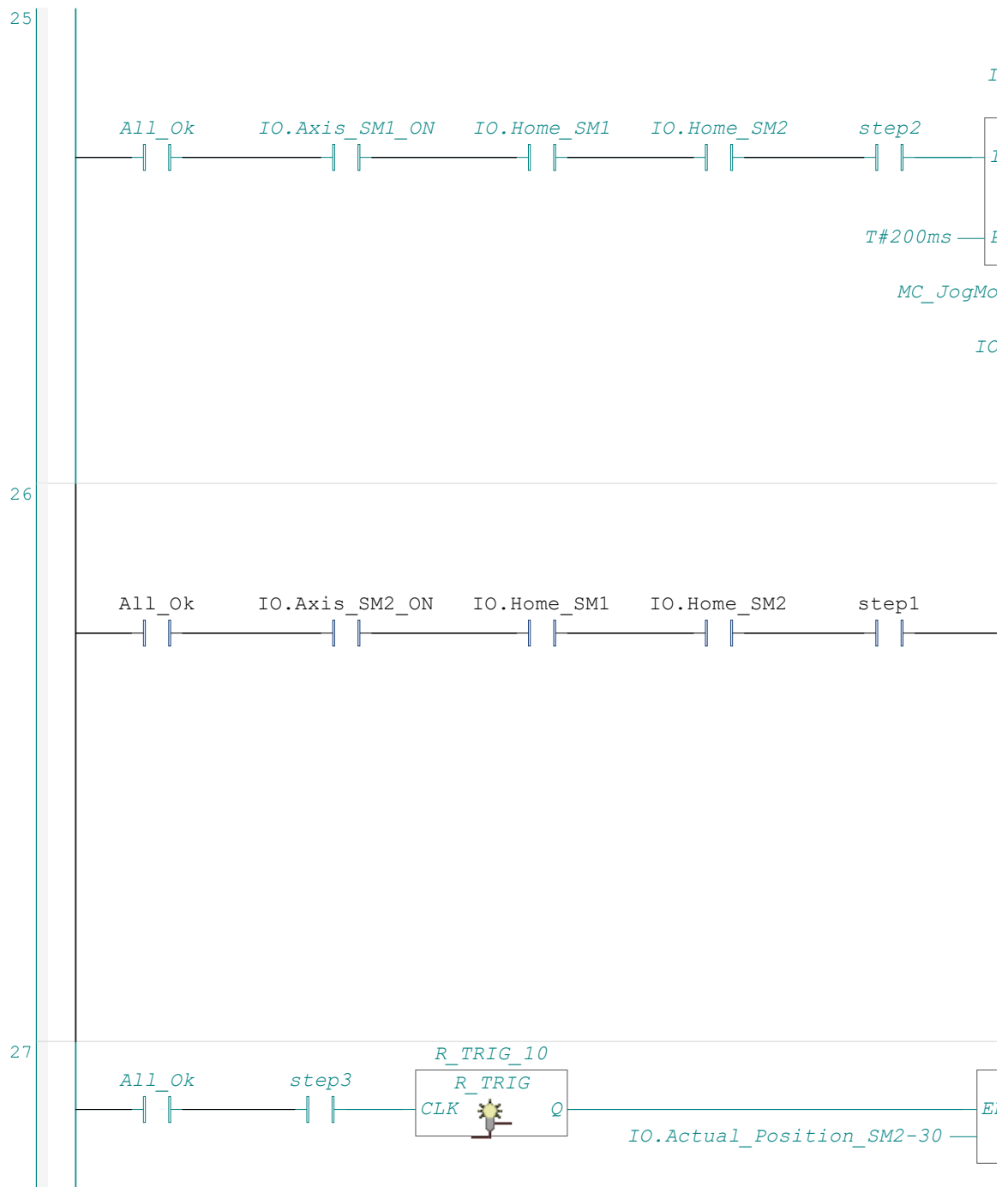

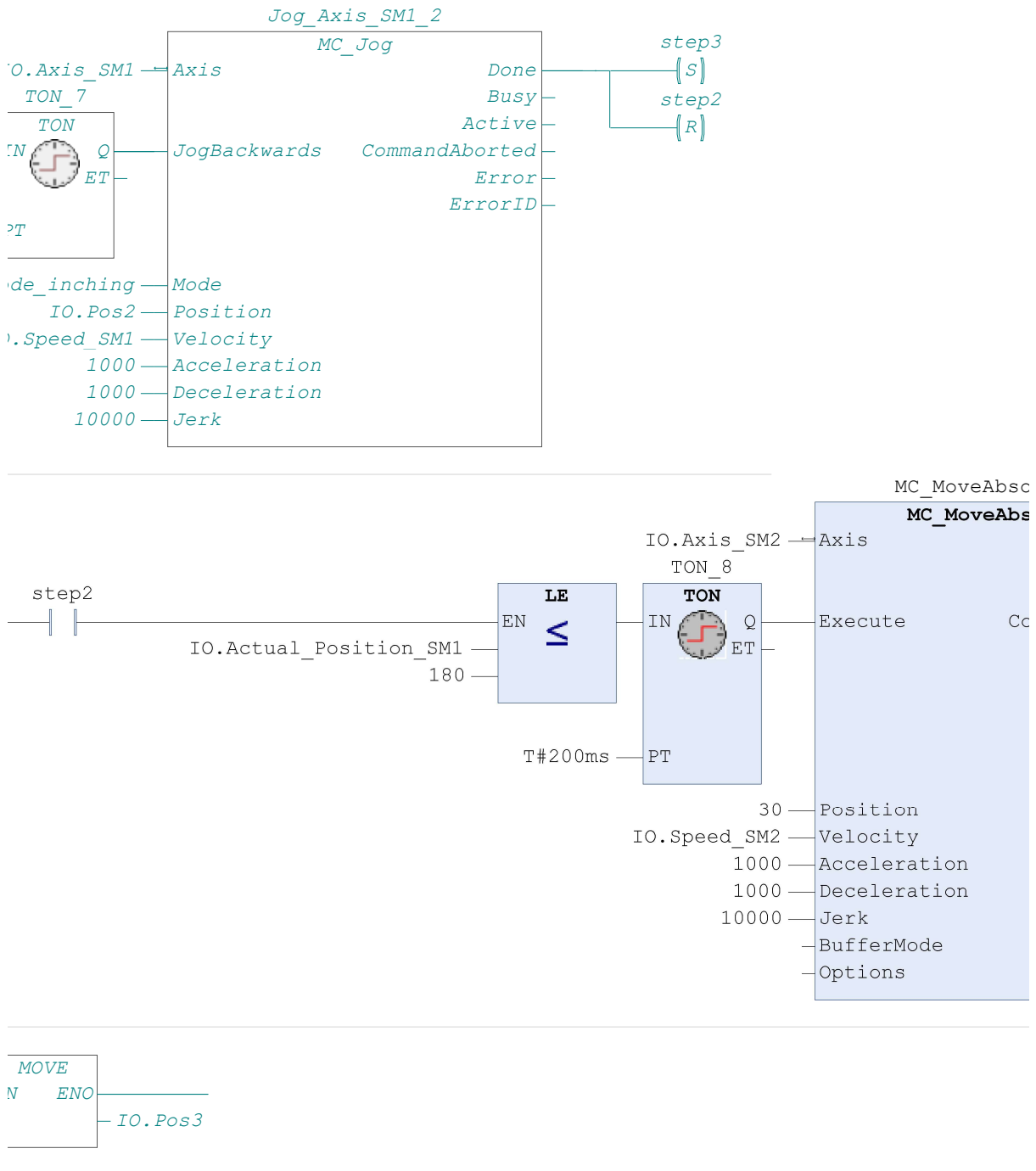

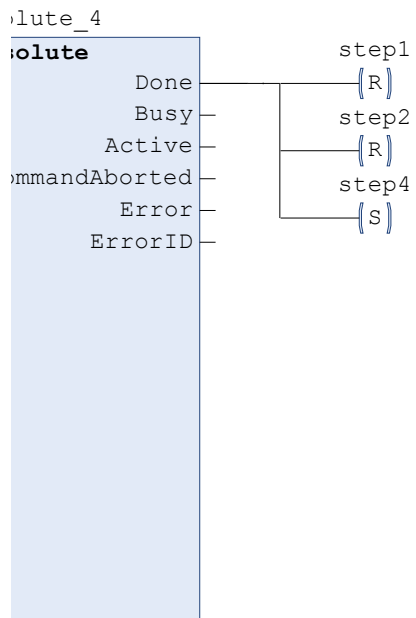

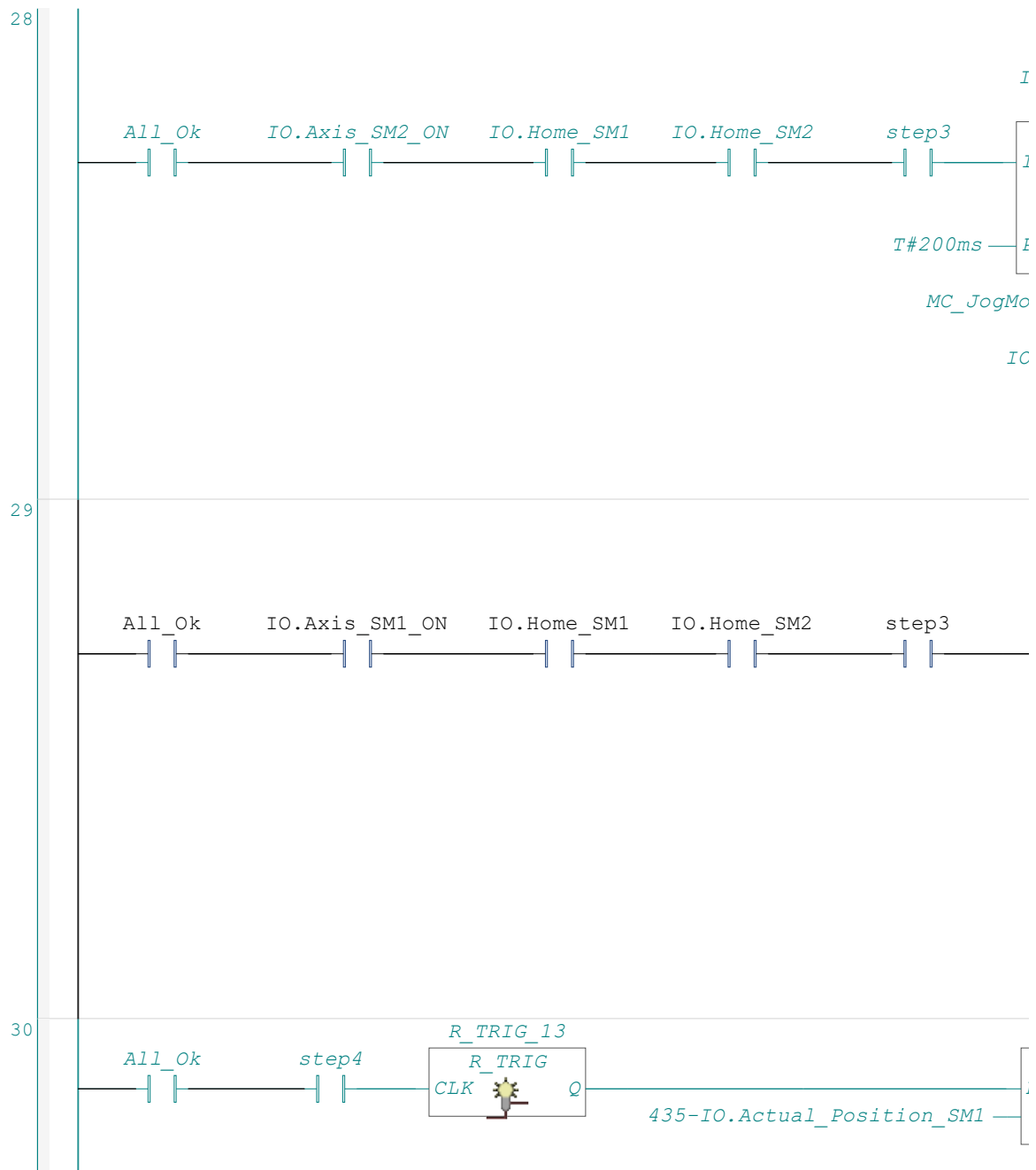

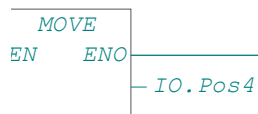
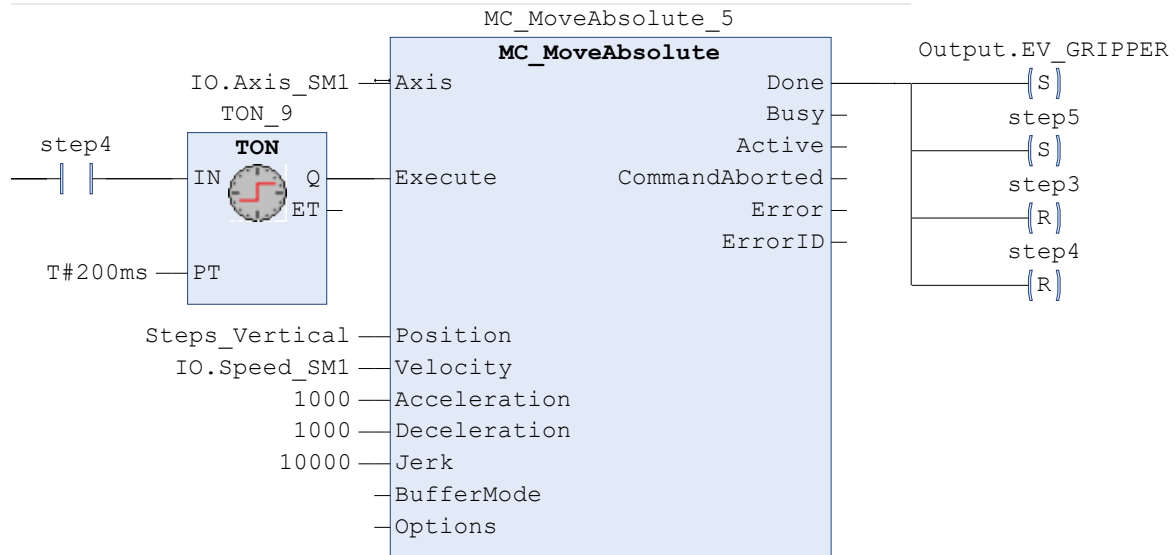
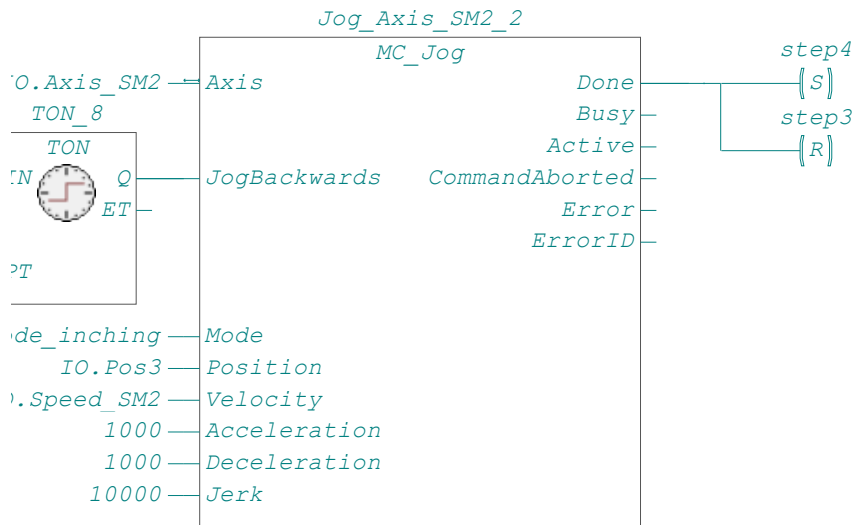

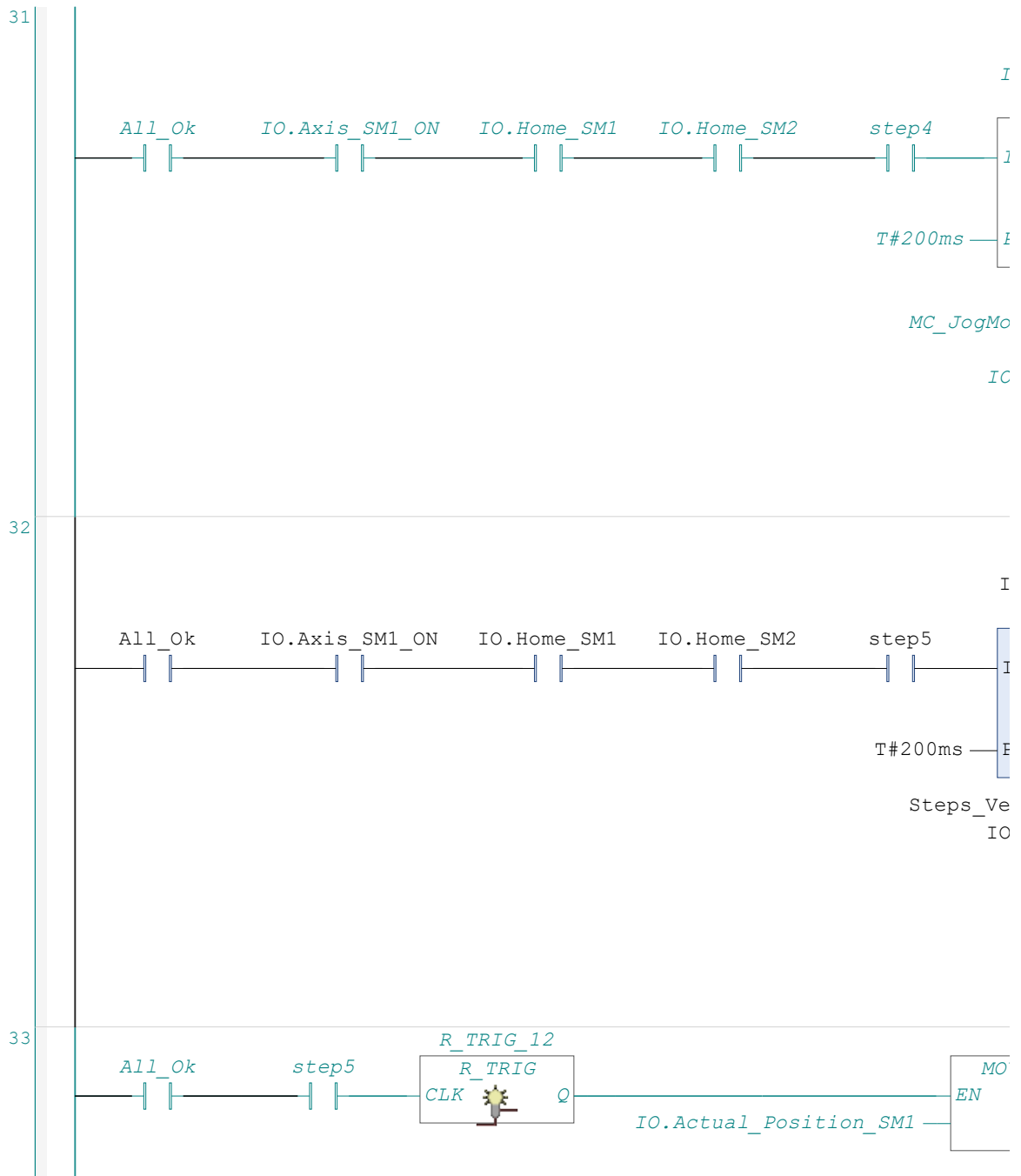

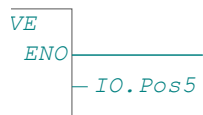
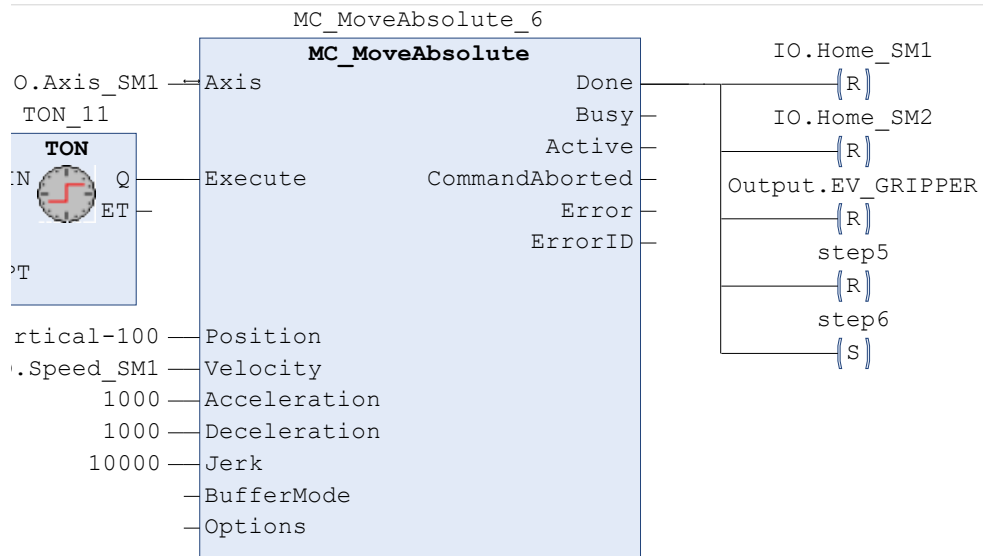
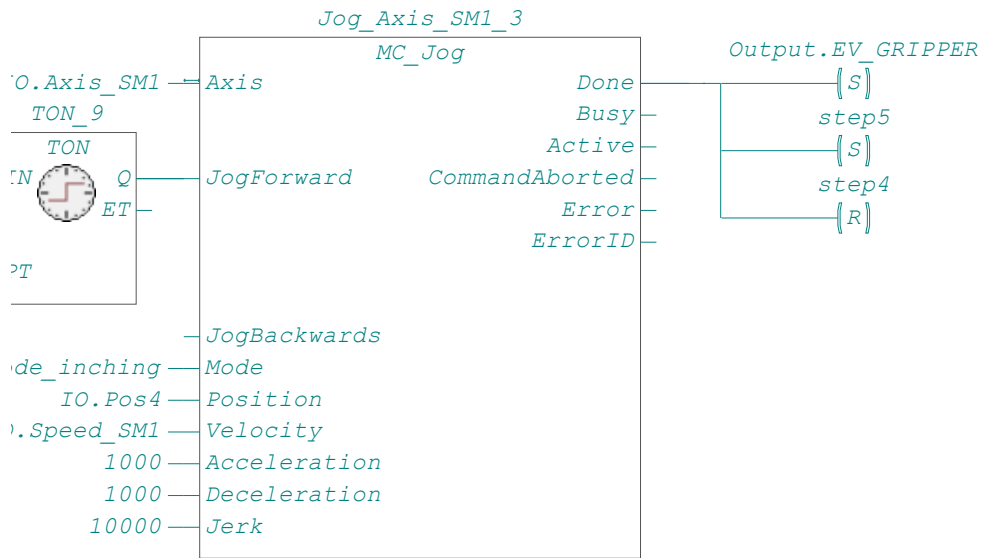

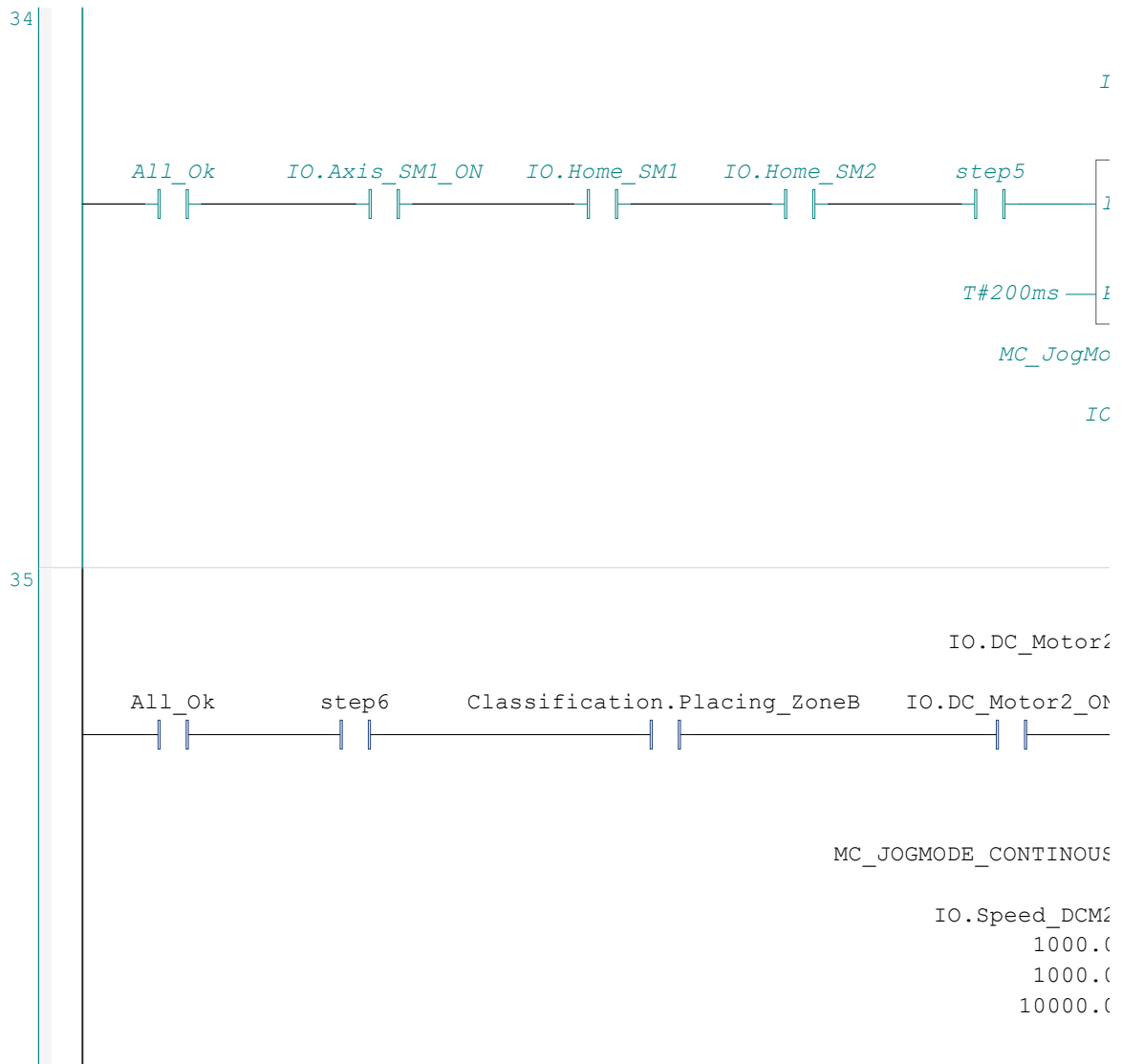

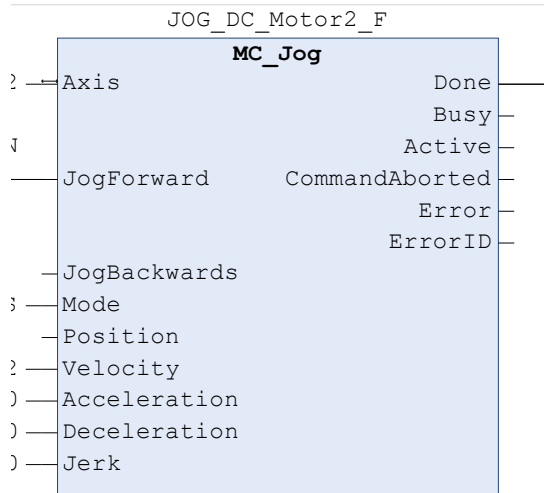
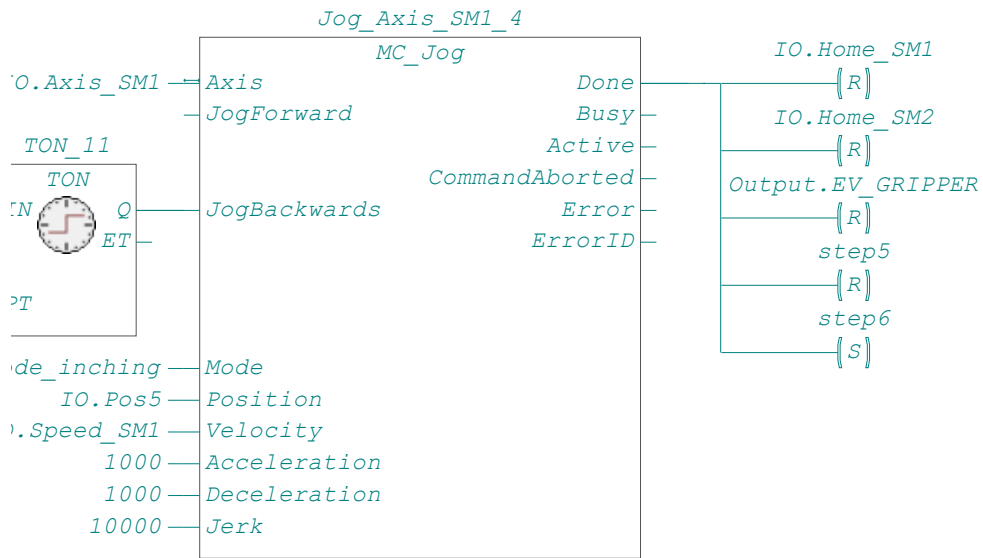

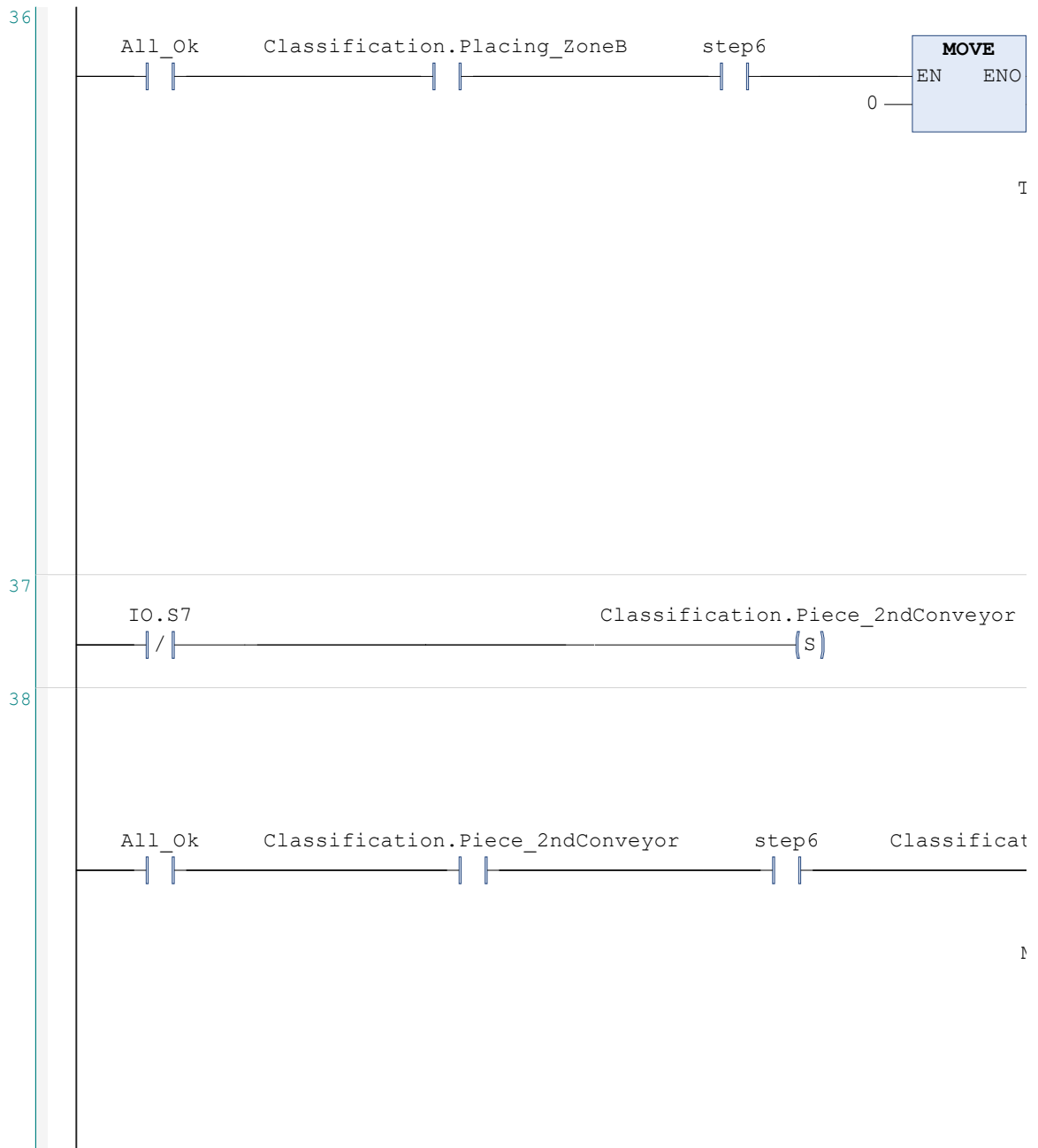

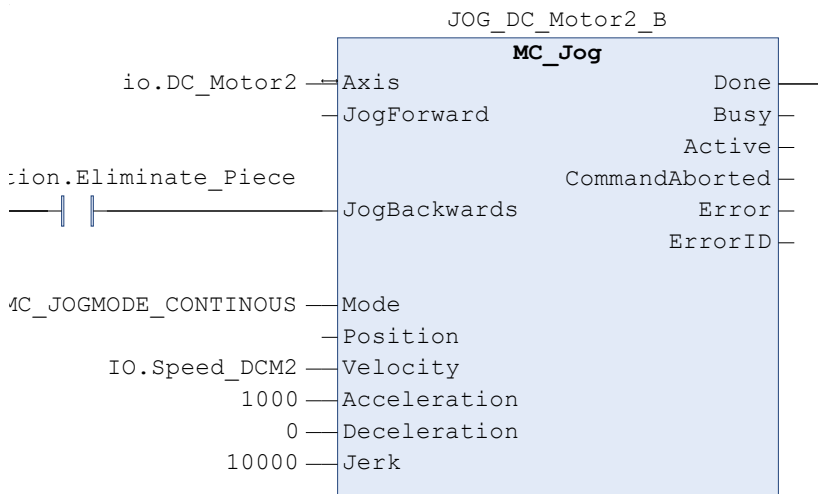
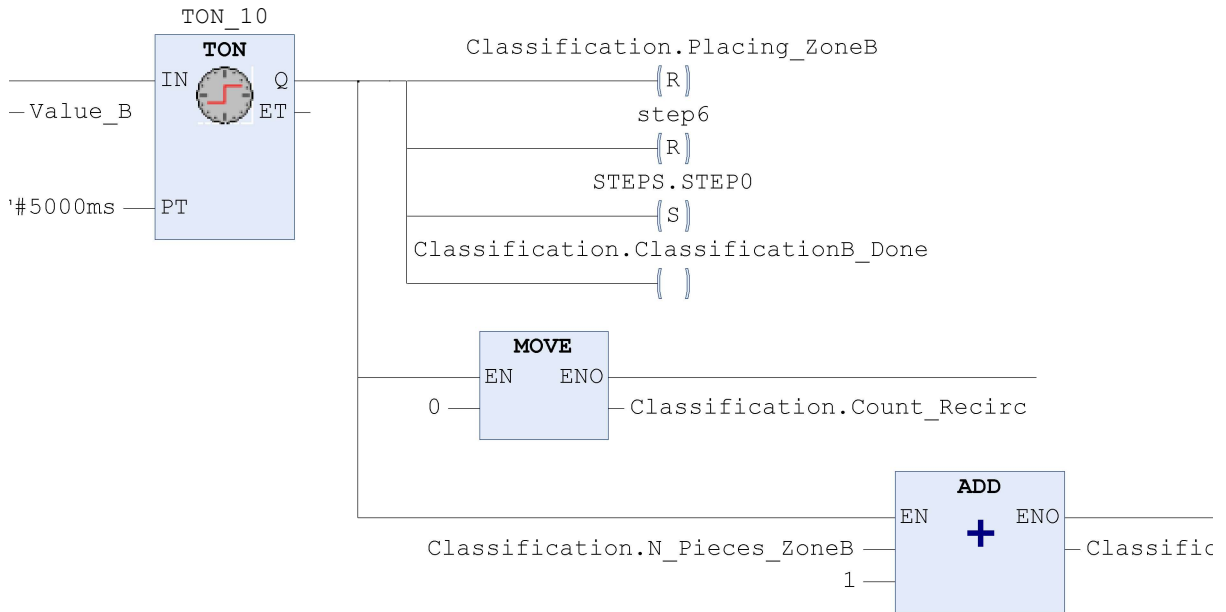

ation.N_Pieces_ZoneB

39

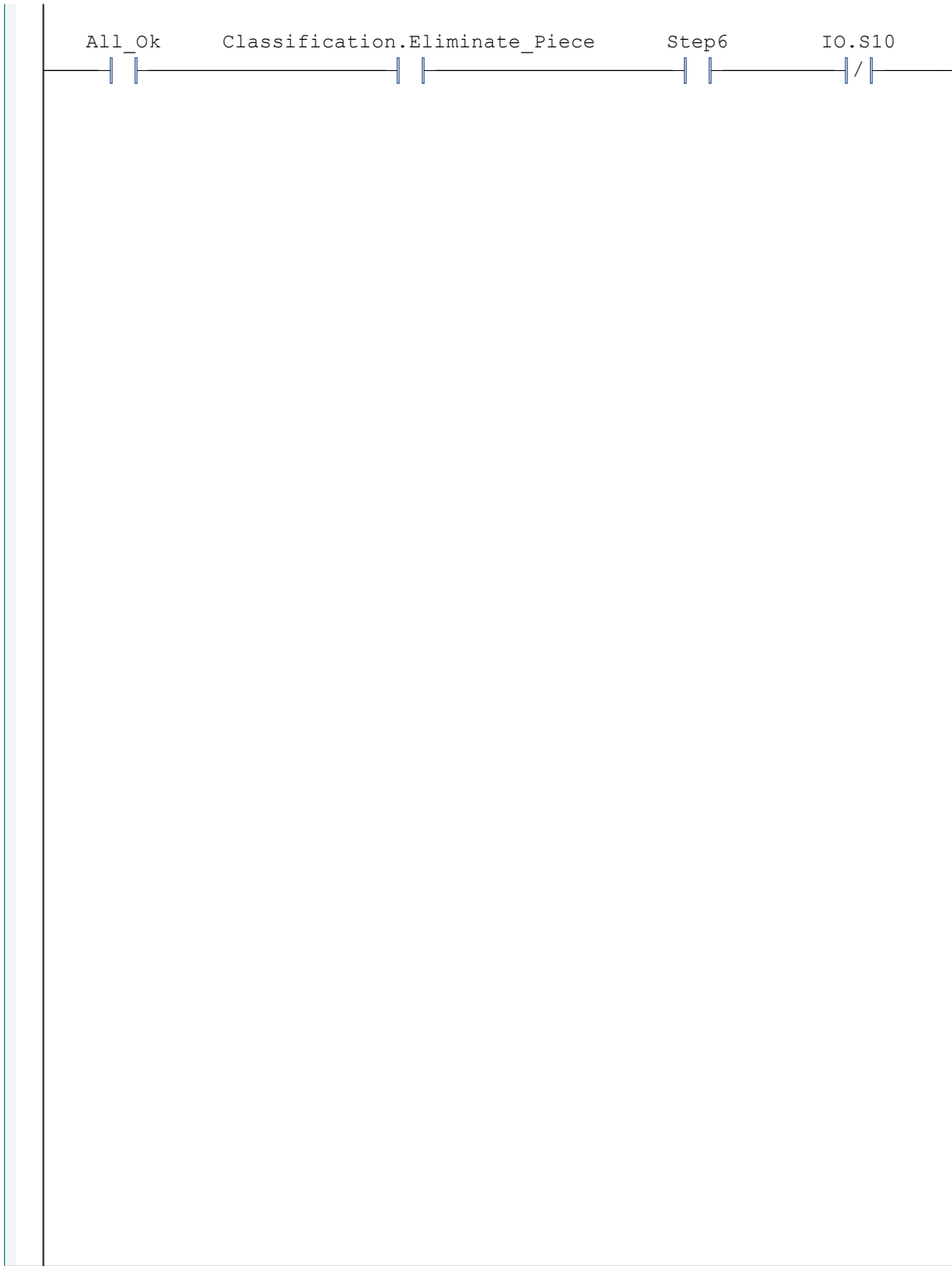

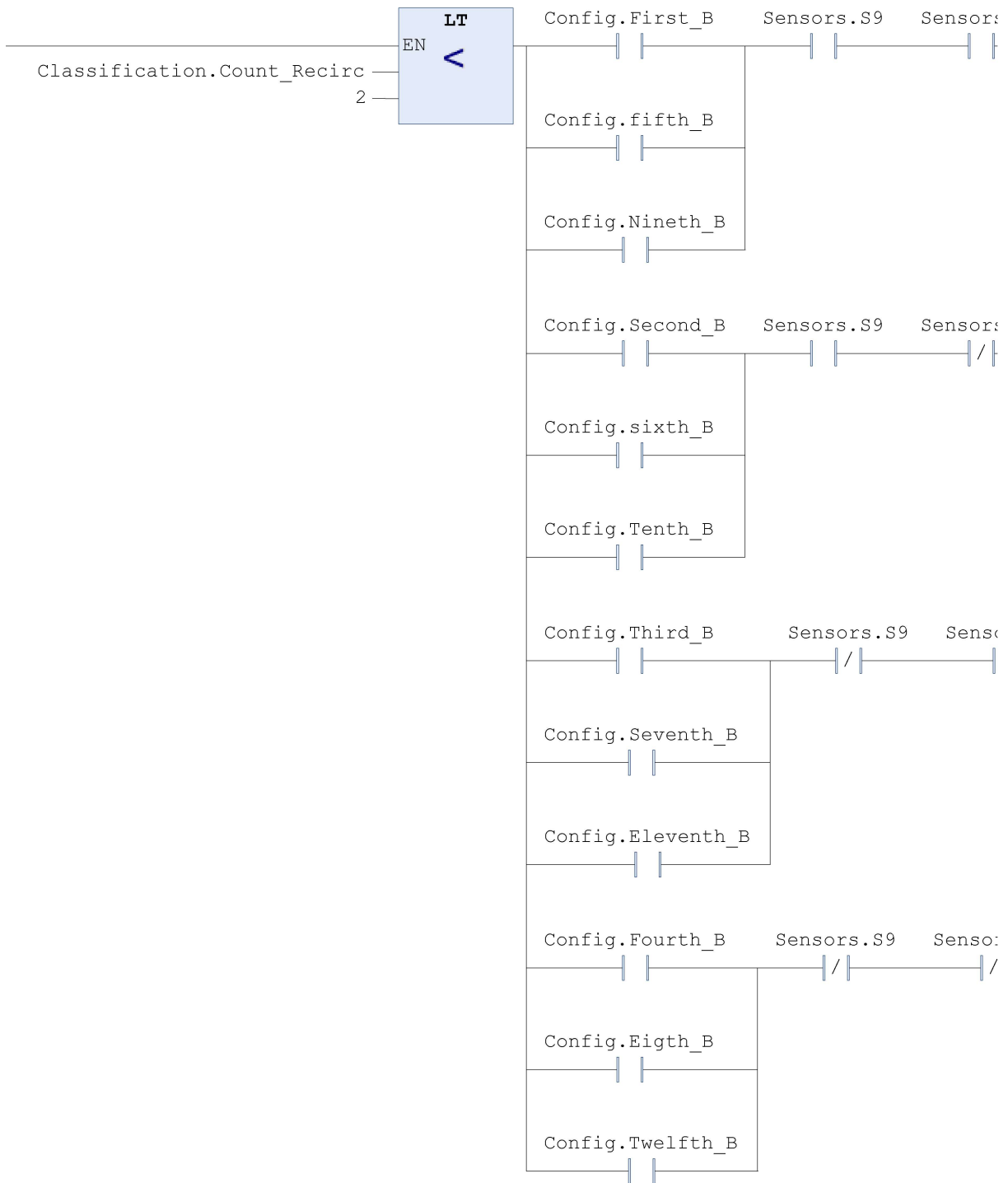

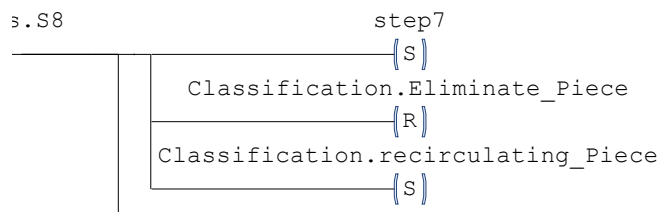

s.S8

ors.S8

rs.S8

40

All_Ok

Classification.Eliminate_Piece

Step6

IO.S10

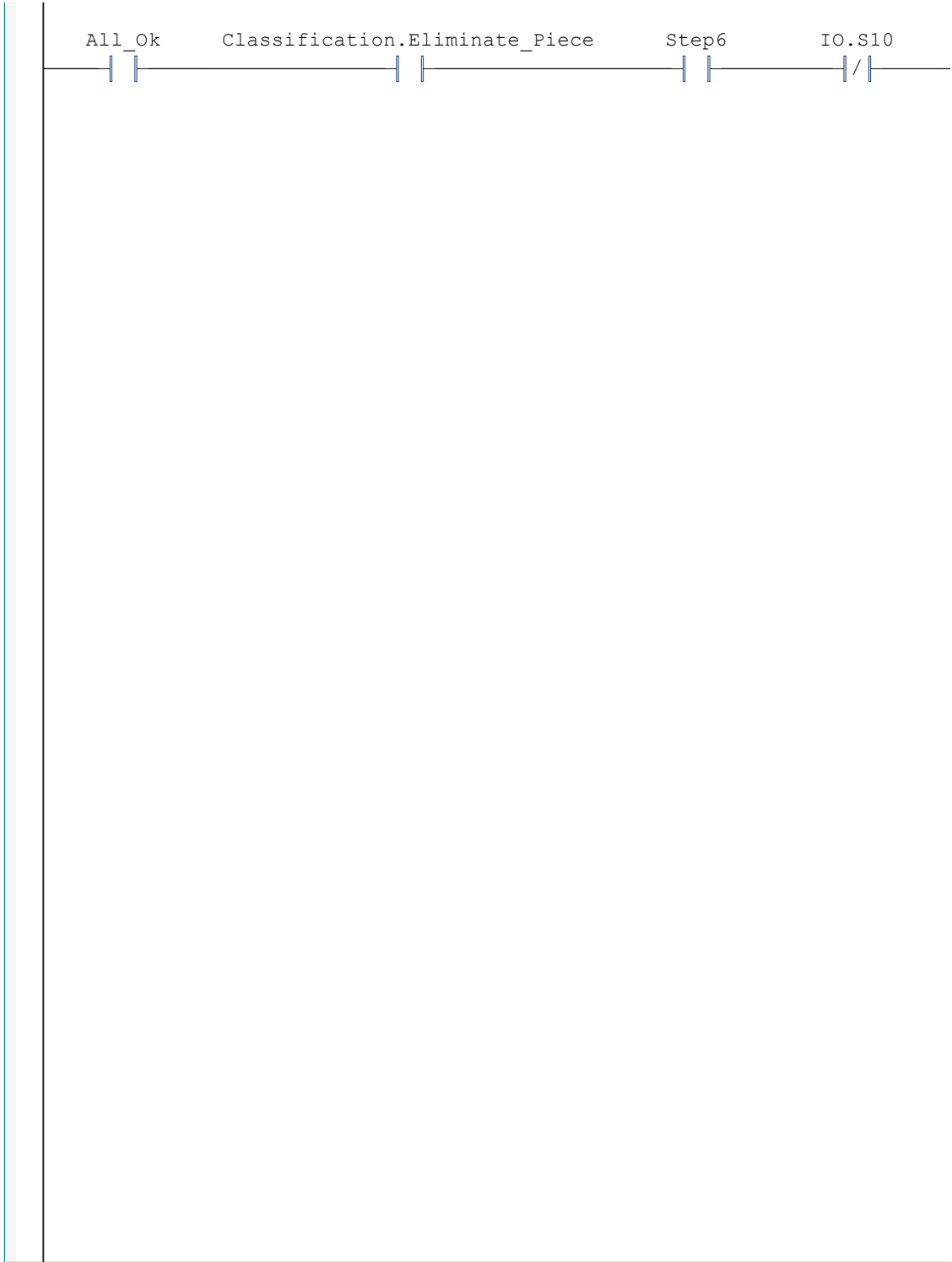

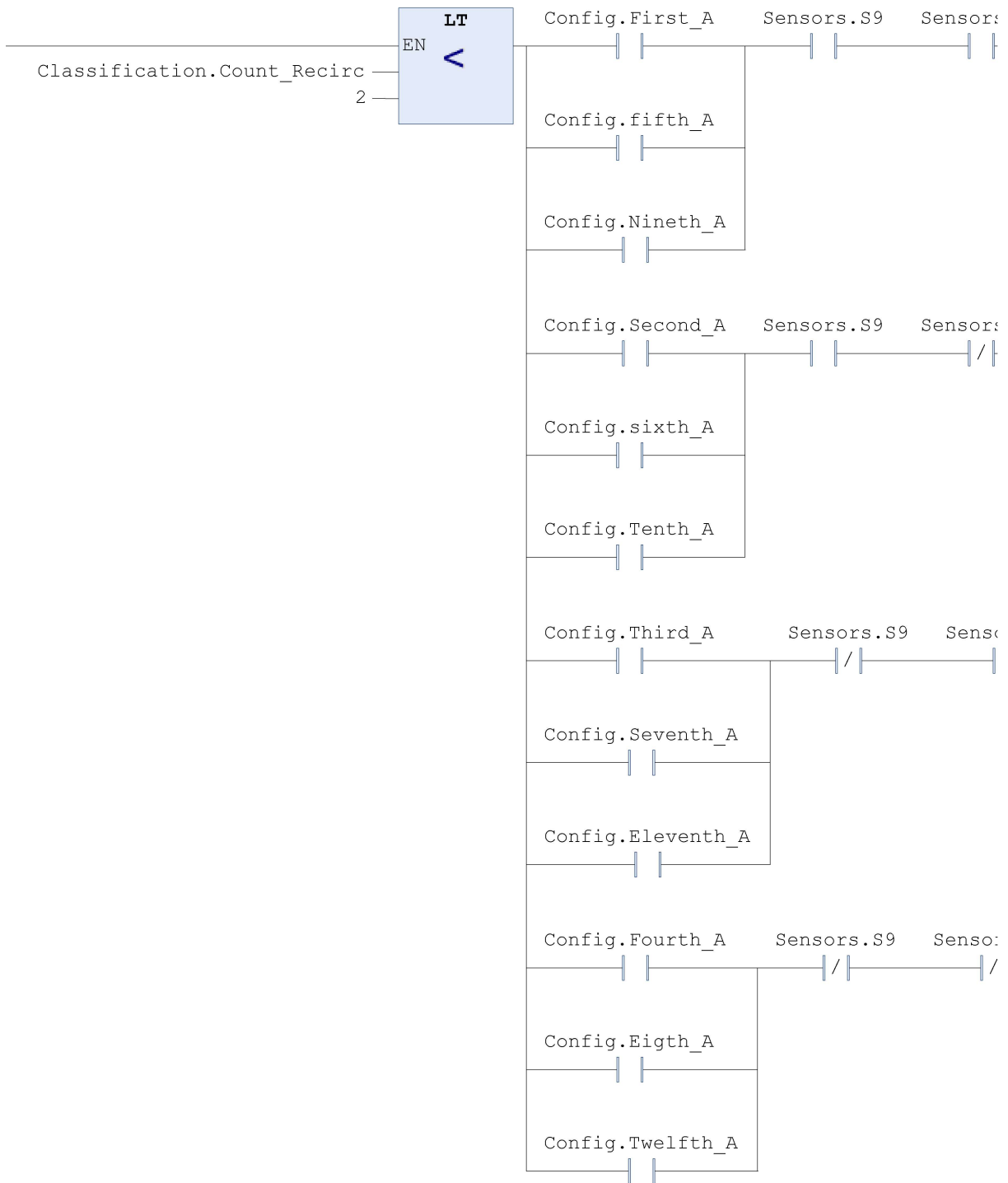

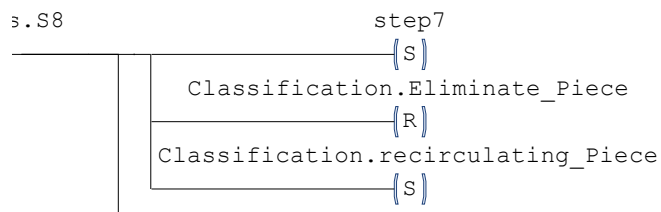

s.S8

ors.S8

rs.S8

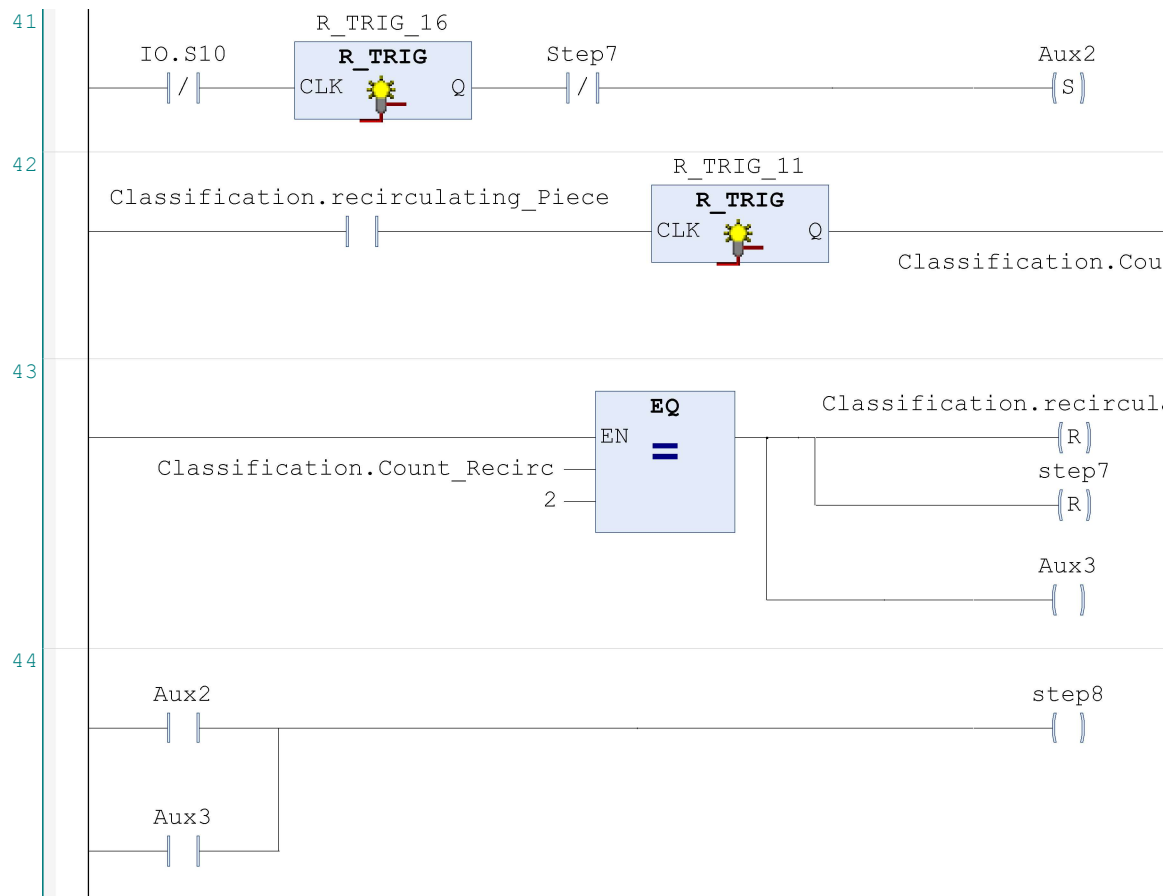

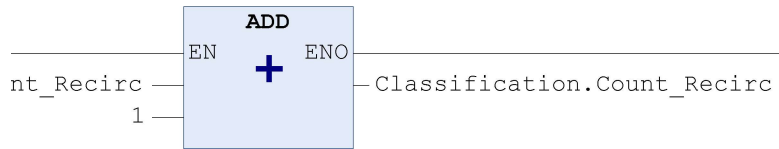

ating_Piece

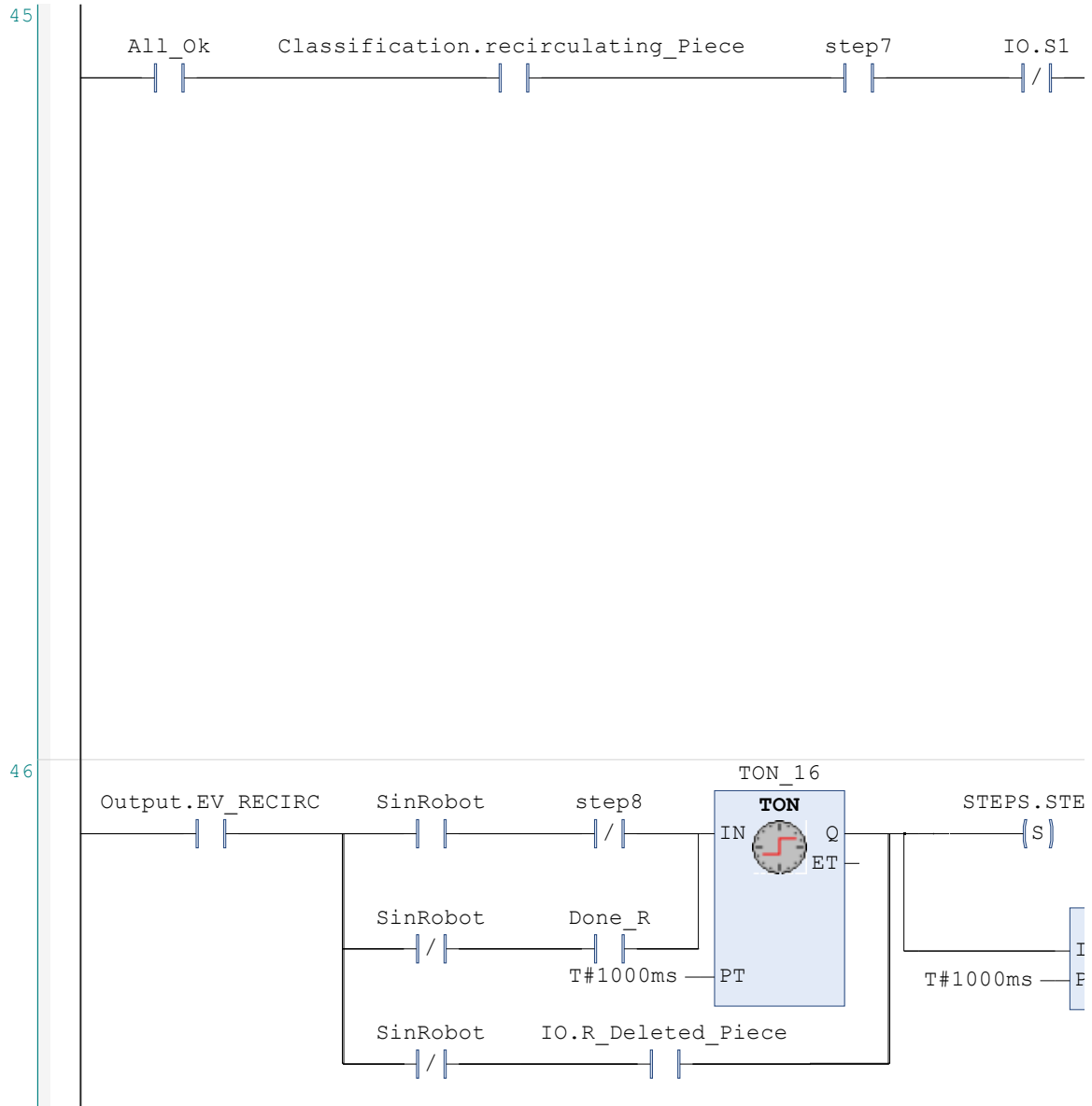

POU: _6_Cycle

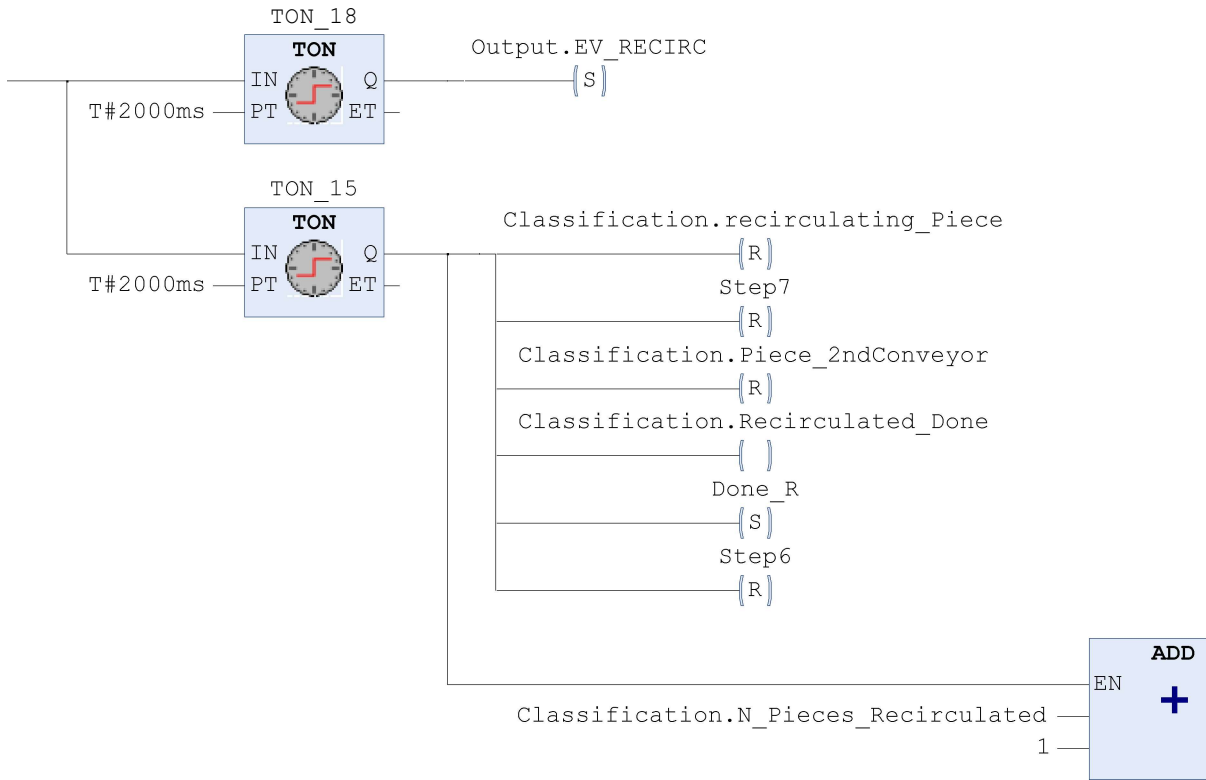

P0

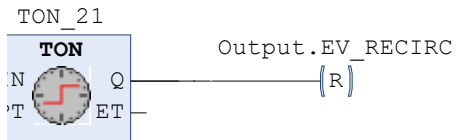

ENO
- Classification.N_Pieces_Recirculated

47

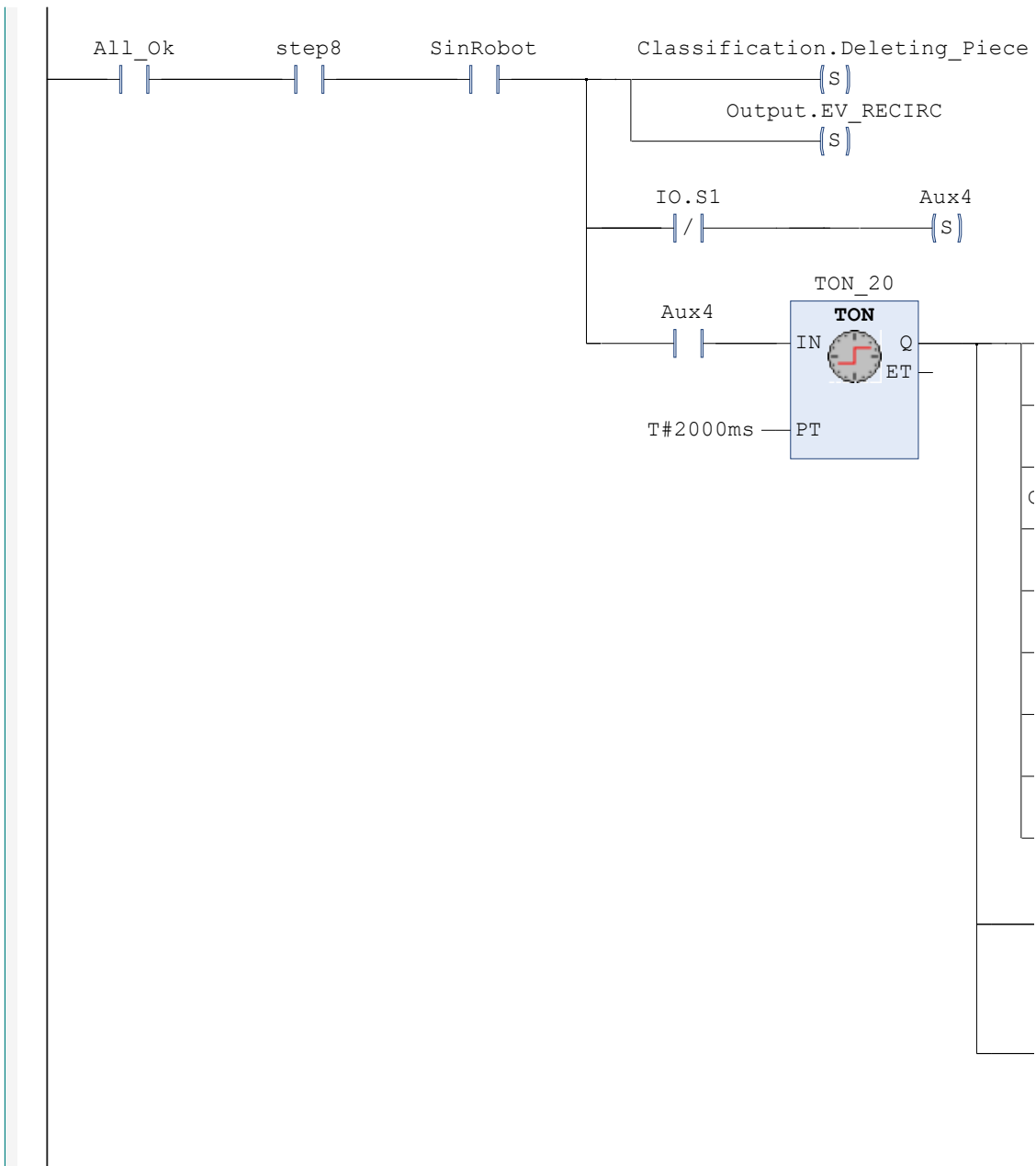

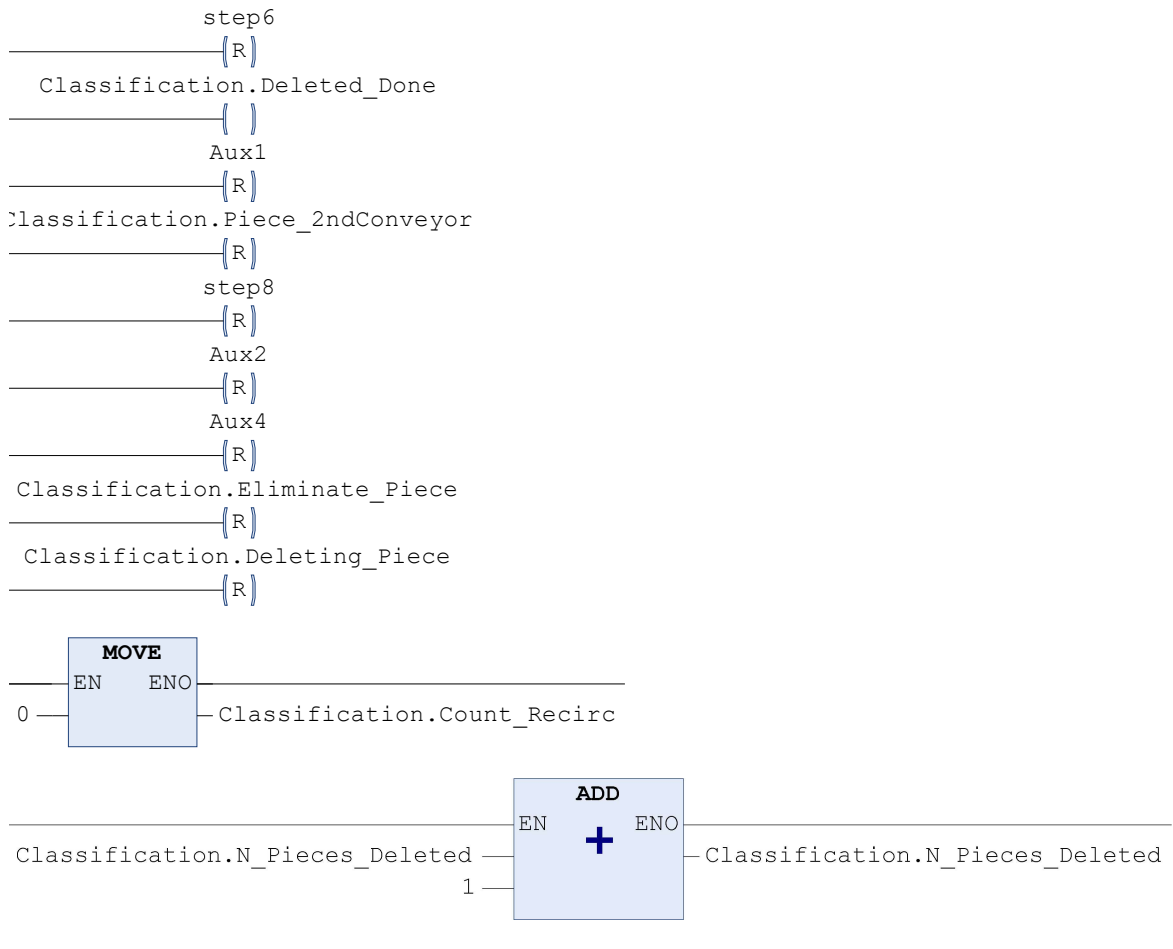

48

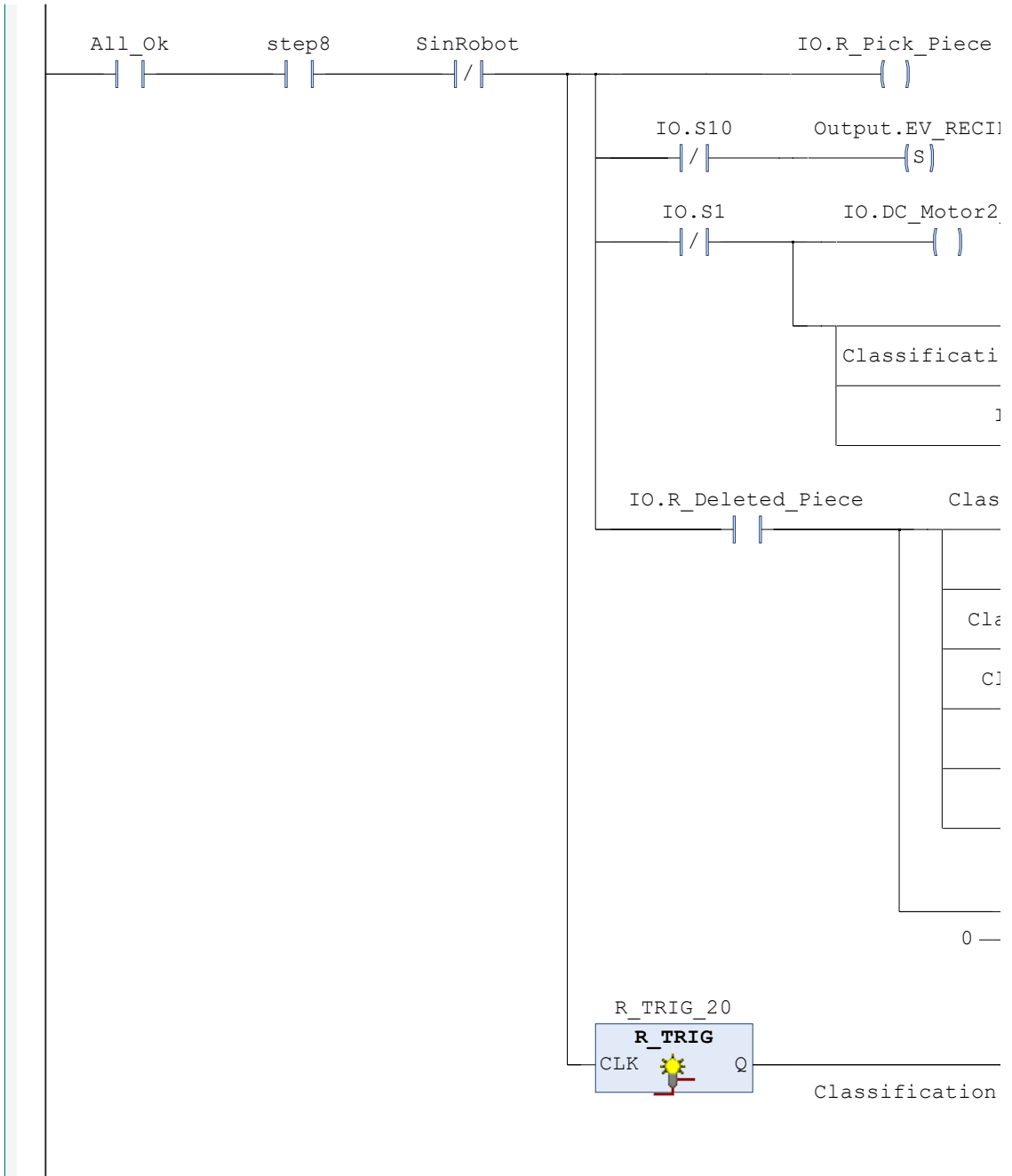

RC

_OFF

step6
—(R)
on.Eliminate_Piece
—(R)
IO.stop
—(S)

Classification.Piece_2ndConveyor
———(R)
step8
———(R)

Classification.Deleting_Piece
———(R)

Classification.Deleted_Done
———()
Aux2
———(R)
IO.stop
———(R)

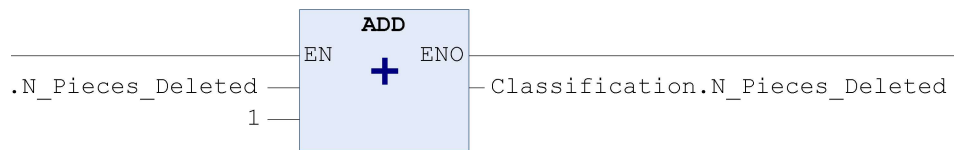
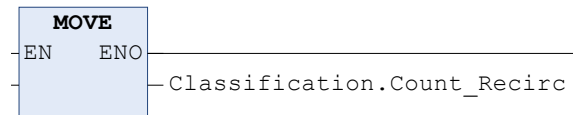

49

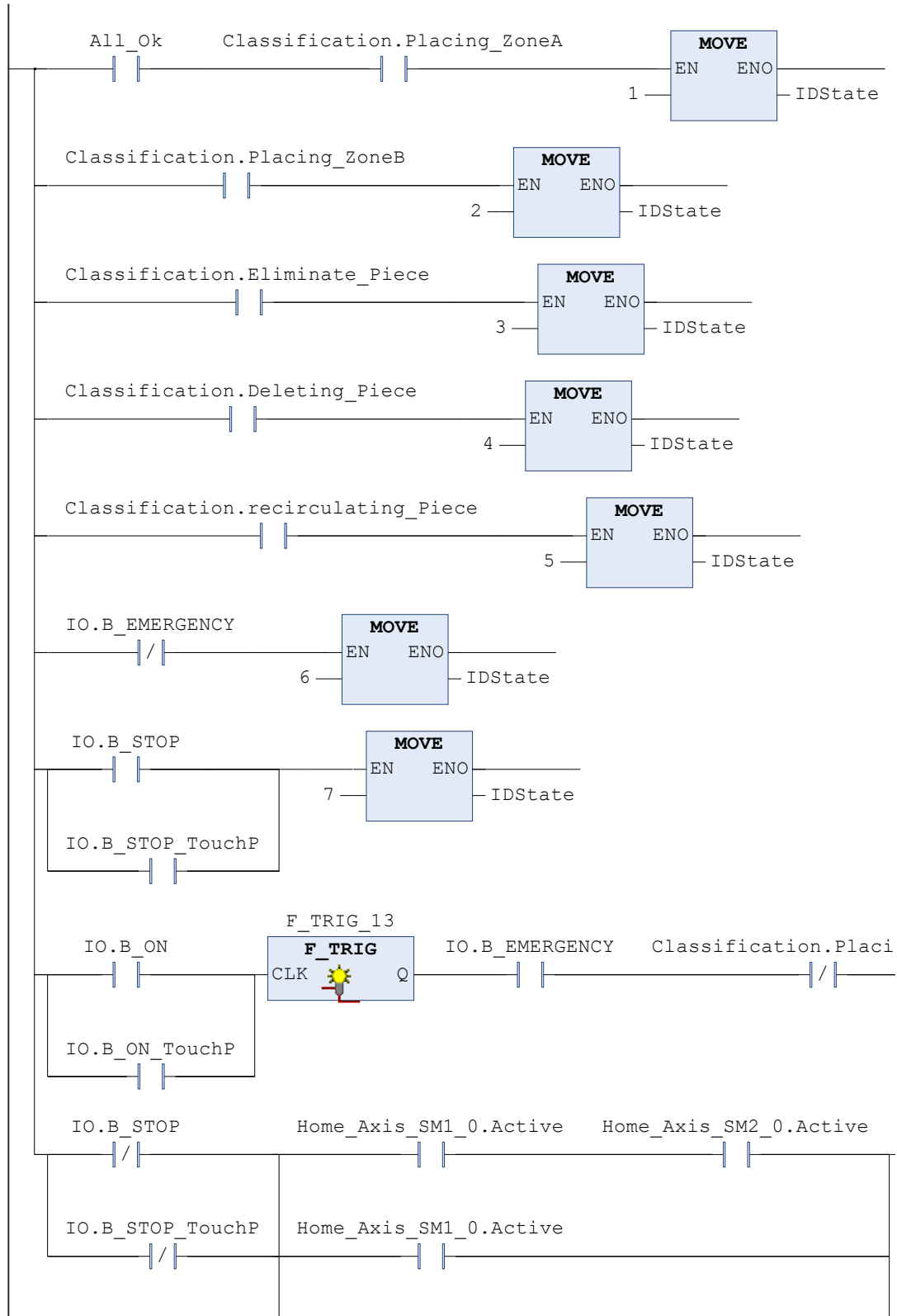

Classification.Deleting_Piece Classification.recirculating_Piece Home_Axis_SM1_0.Act

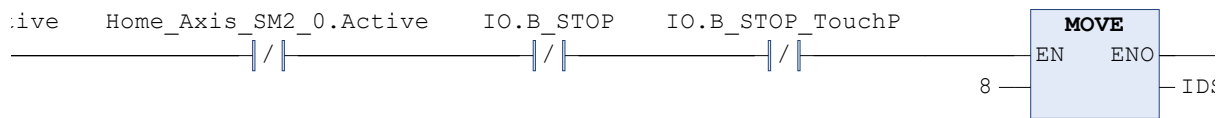

state

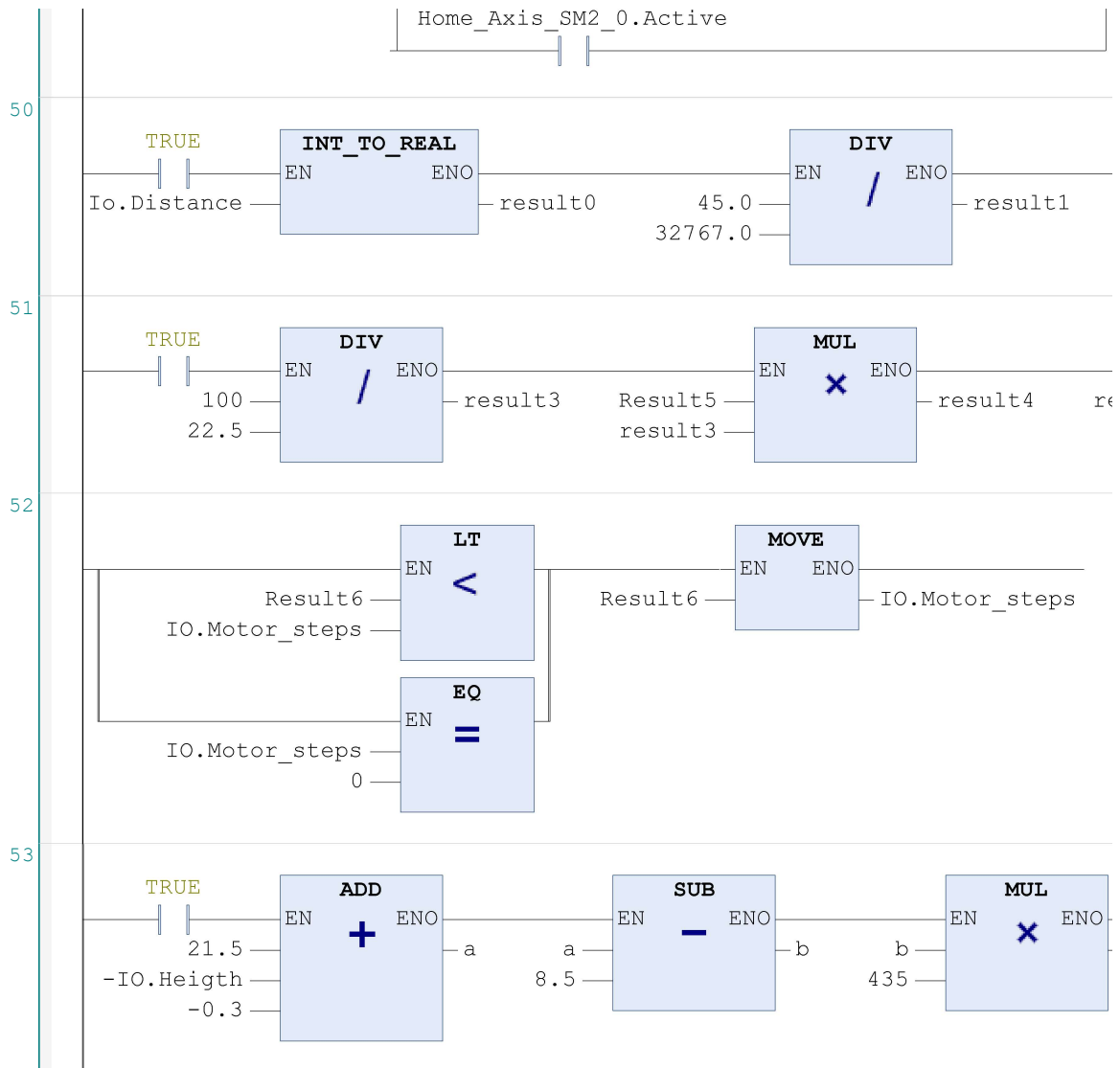

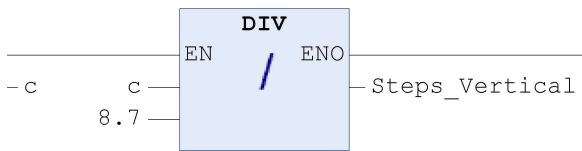
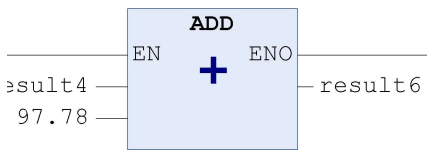
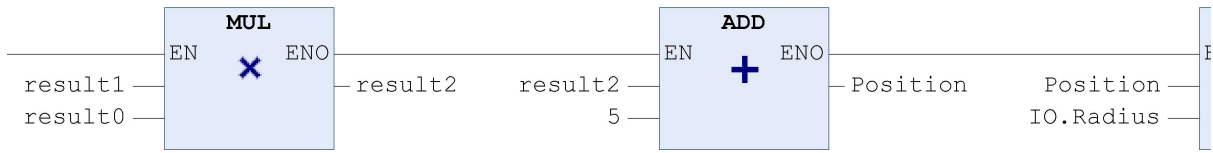

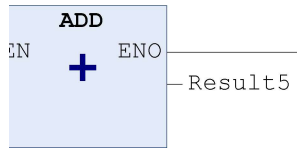

54

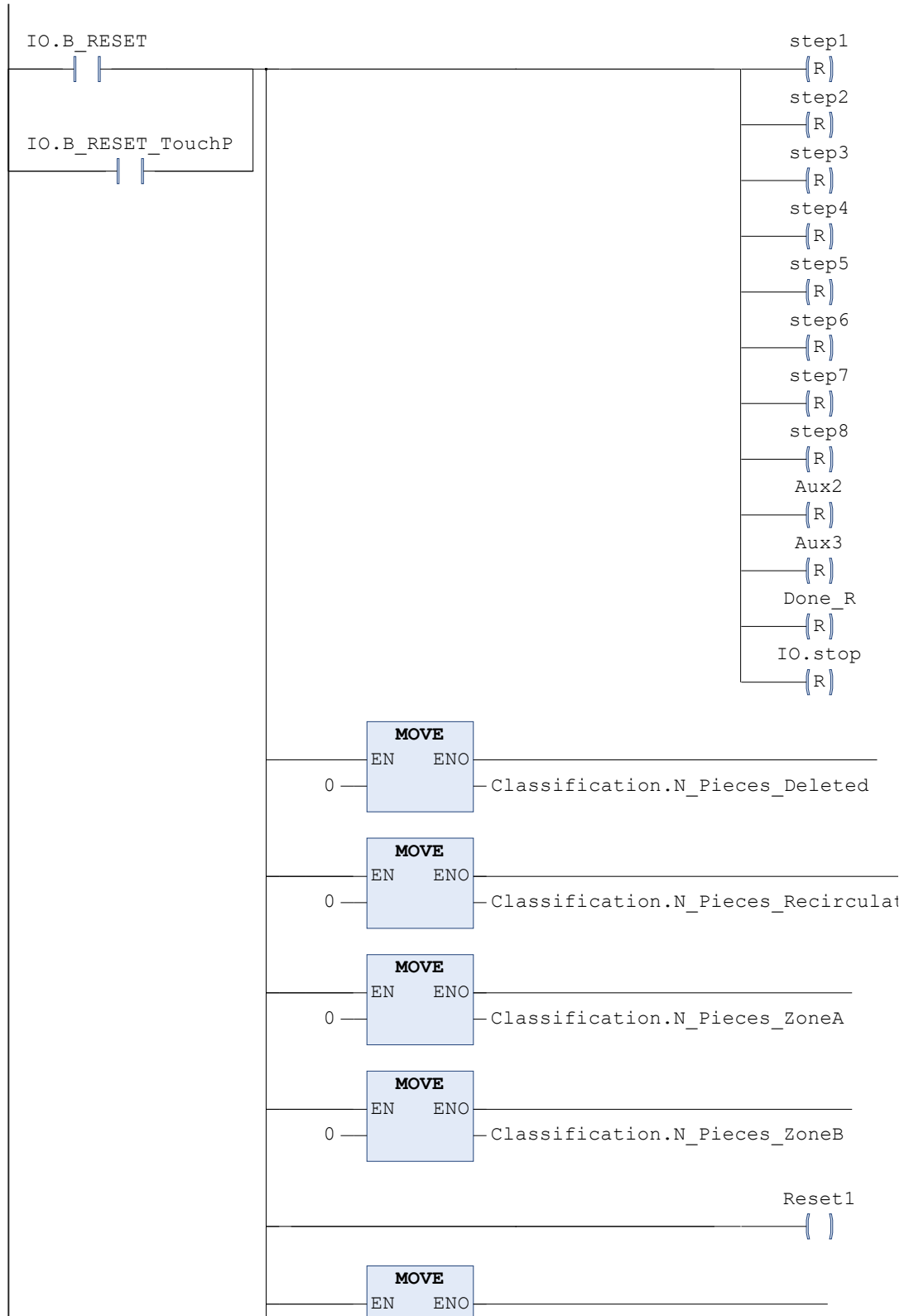

—
ced

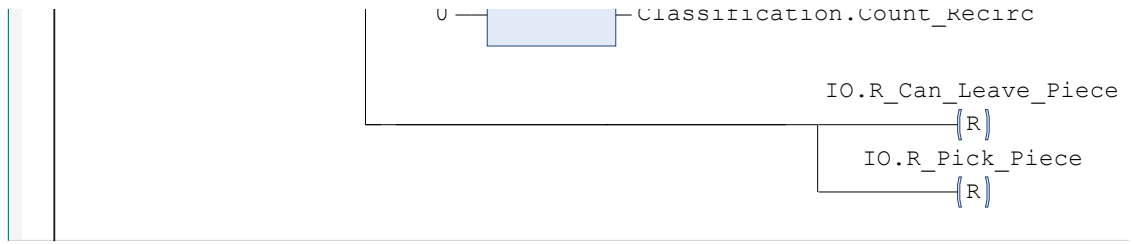

POU: _7_Manual_Mov

```

1  PROGRAM _7_Manual_Mov
2  VAR
3      Power_DC_Motor2_Manual : MC_Power ;
4      JOG_DC_Motor2_manual : MC_Jog ;
5      Power_Axis_SM1_Manual : MC_Power ;
6      Jog_Axis_SM2_Manual : MC_Jog ;
7      Jog_Axis_SM1_Manual : MC_Jog ;
8      Power_Axis_SM2_Manual : MC_Power ;
9  END_VAR
10

```

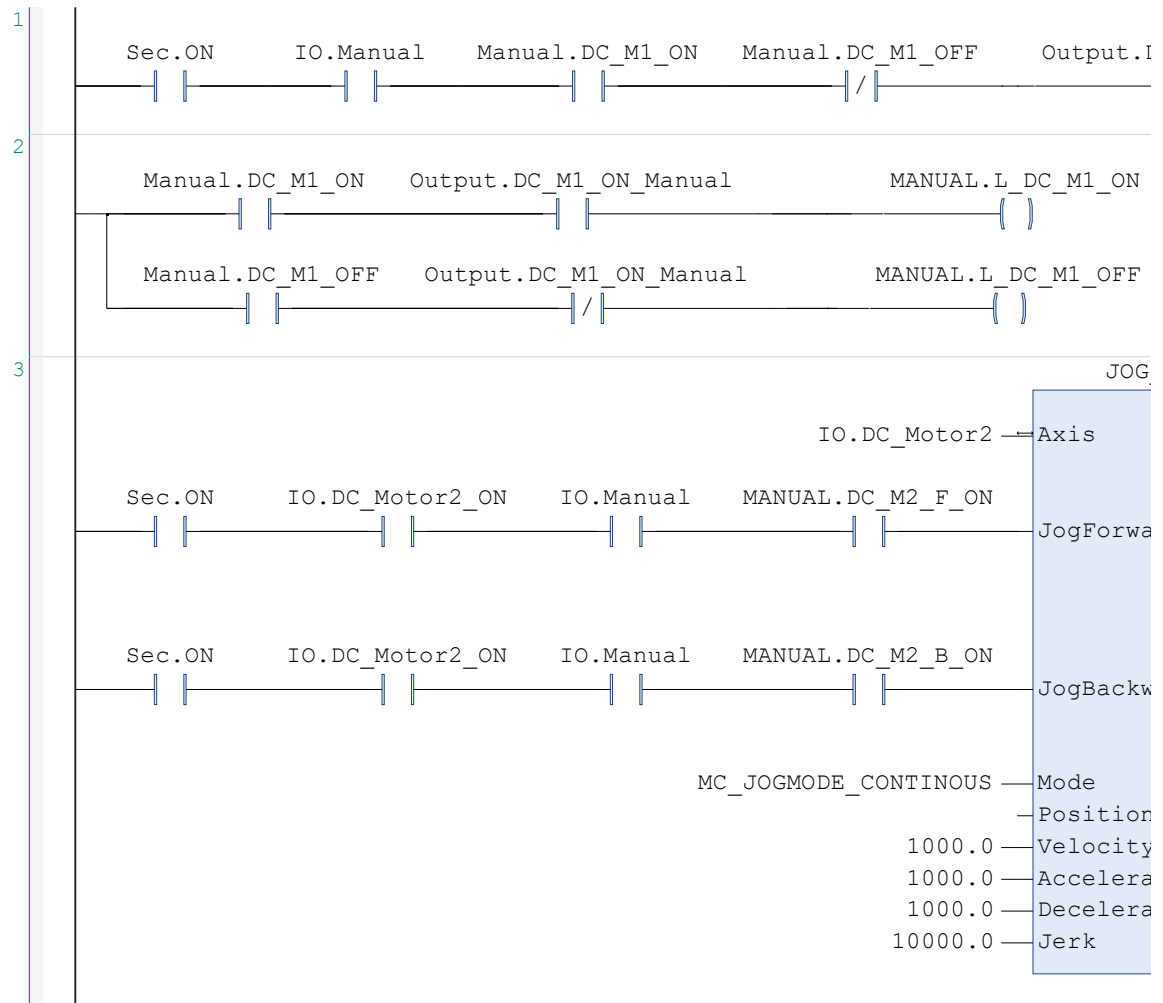

DC_M1_ON_Manual
— ()

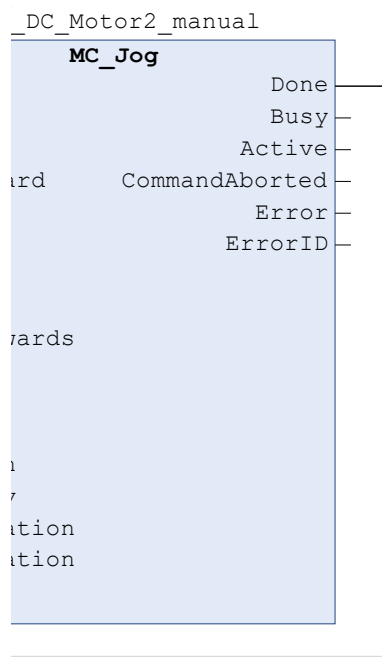

POU: _7_Manual_Mov

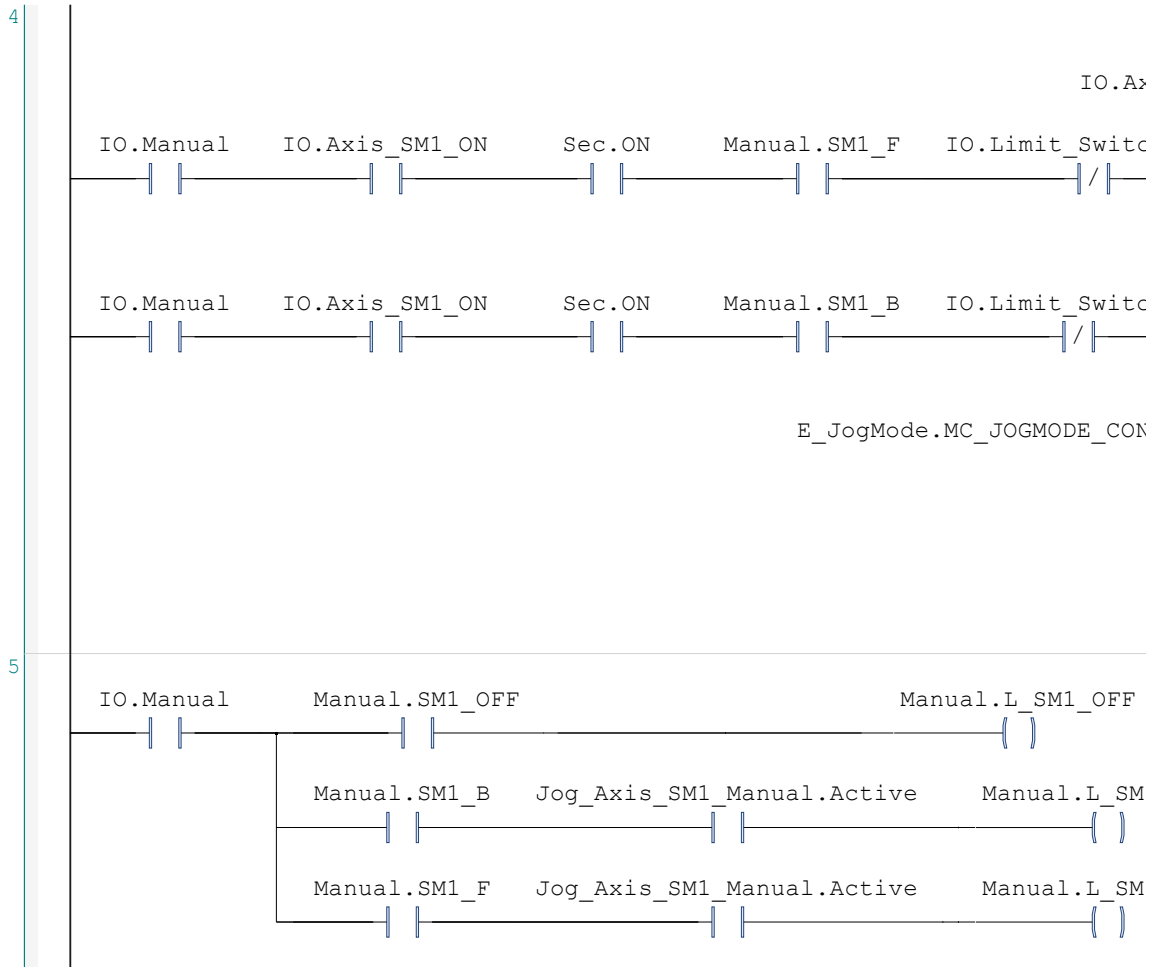

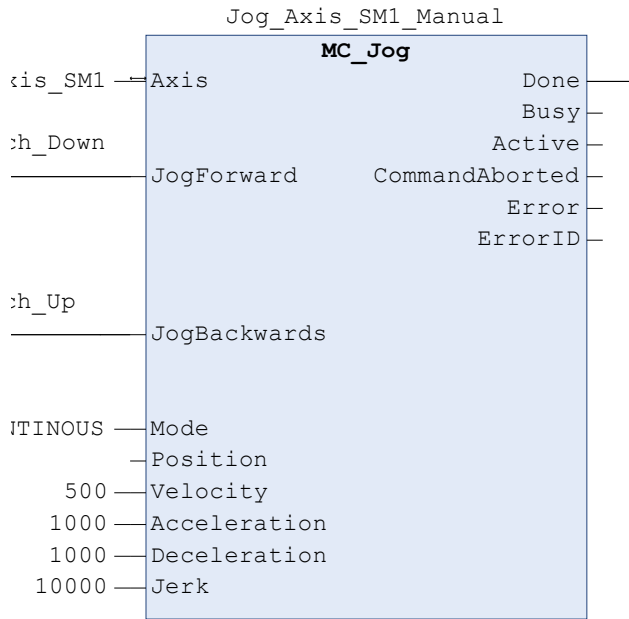

1_B_ON

1_F_ON

POU: _7_Manual_Mov

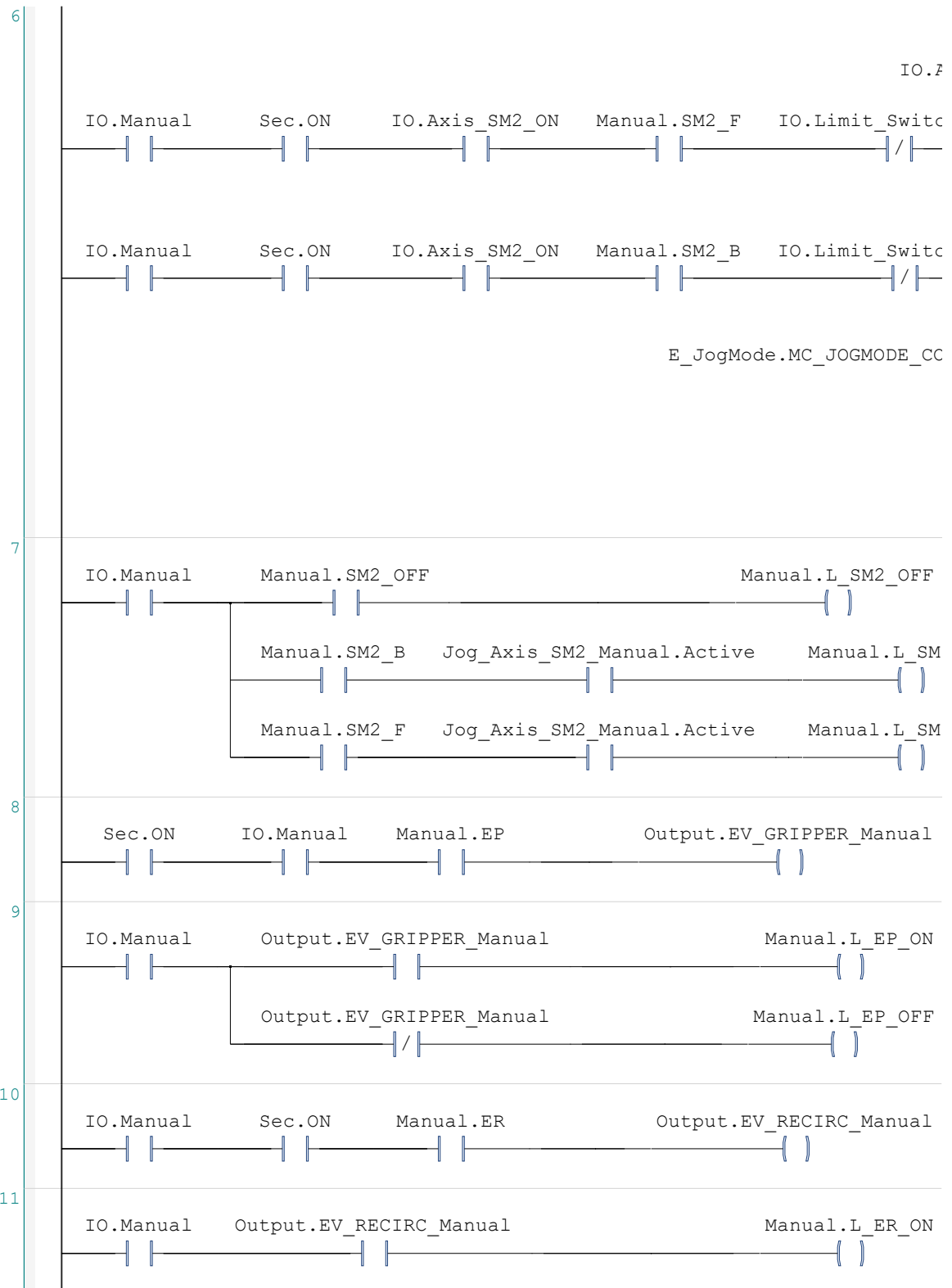

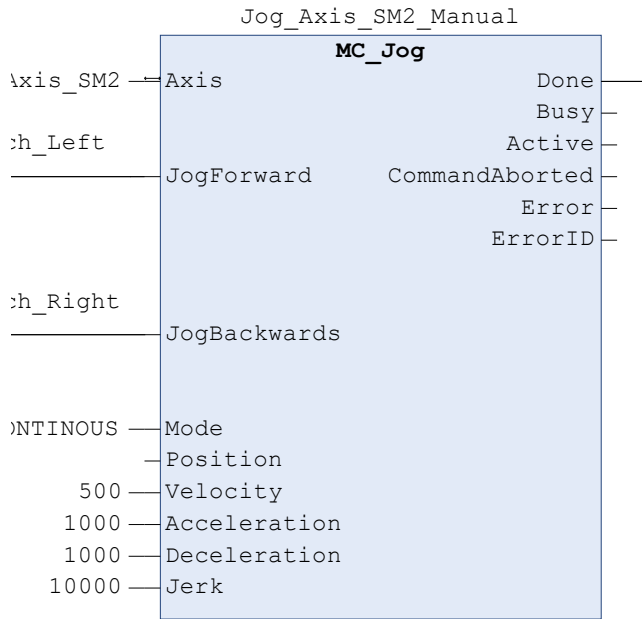

2_B_ON

2_F_ON

POU: _7_Manual_Mov

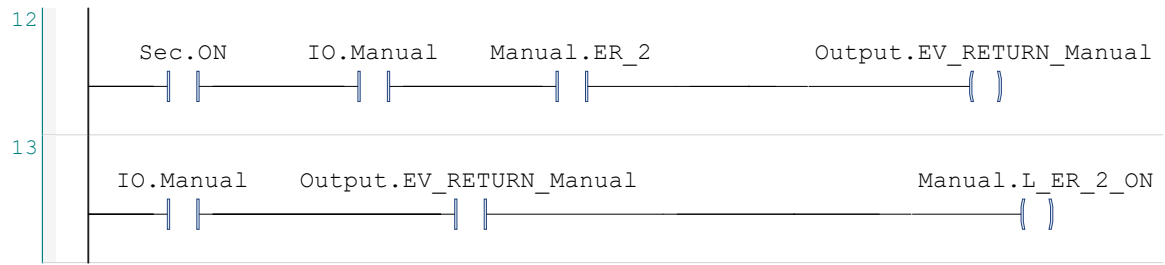

POU: _8_Touch_Panel

```

1  PROGRAM _8_Touch_Panel
2  VAR
3
4      ADS : FB_AdsReadEvents ;
5      FB_ADS : FB_AdsReadEvents ;
6  END_VAR
7

```

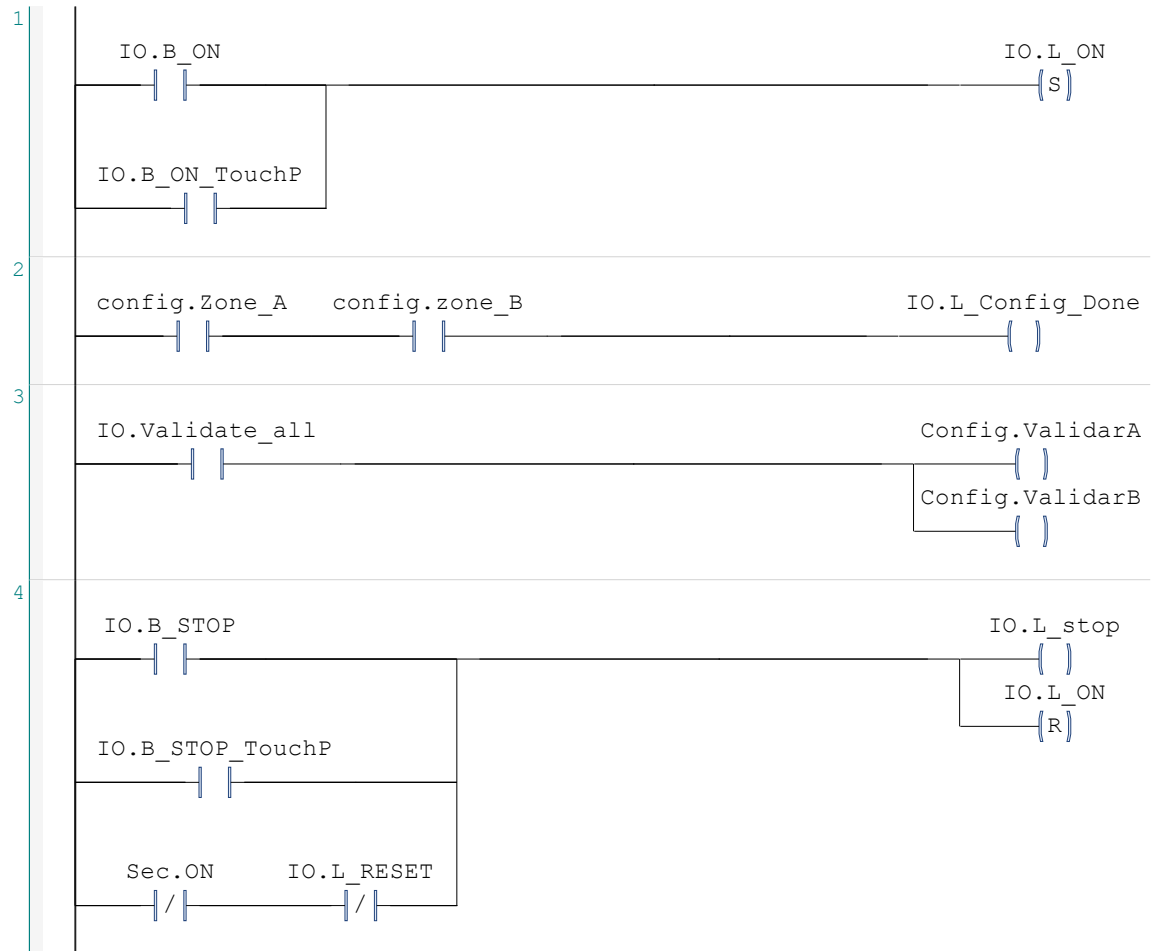

POU: _8_Touch_Panel

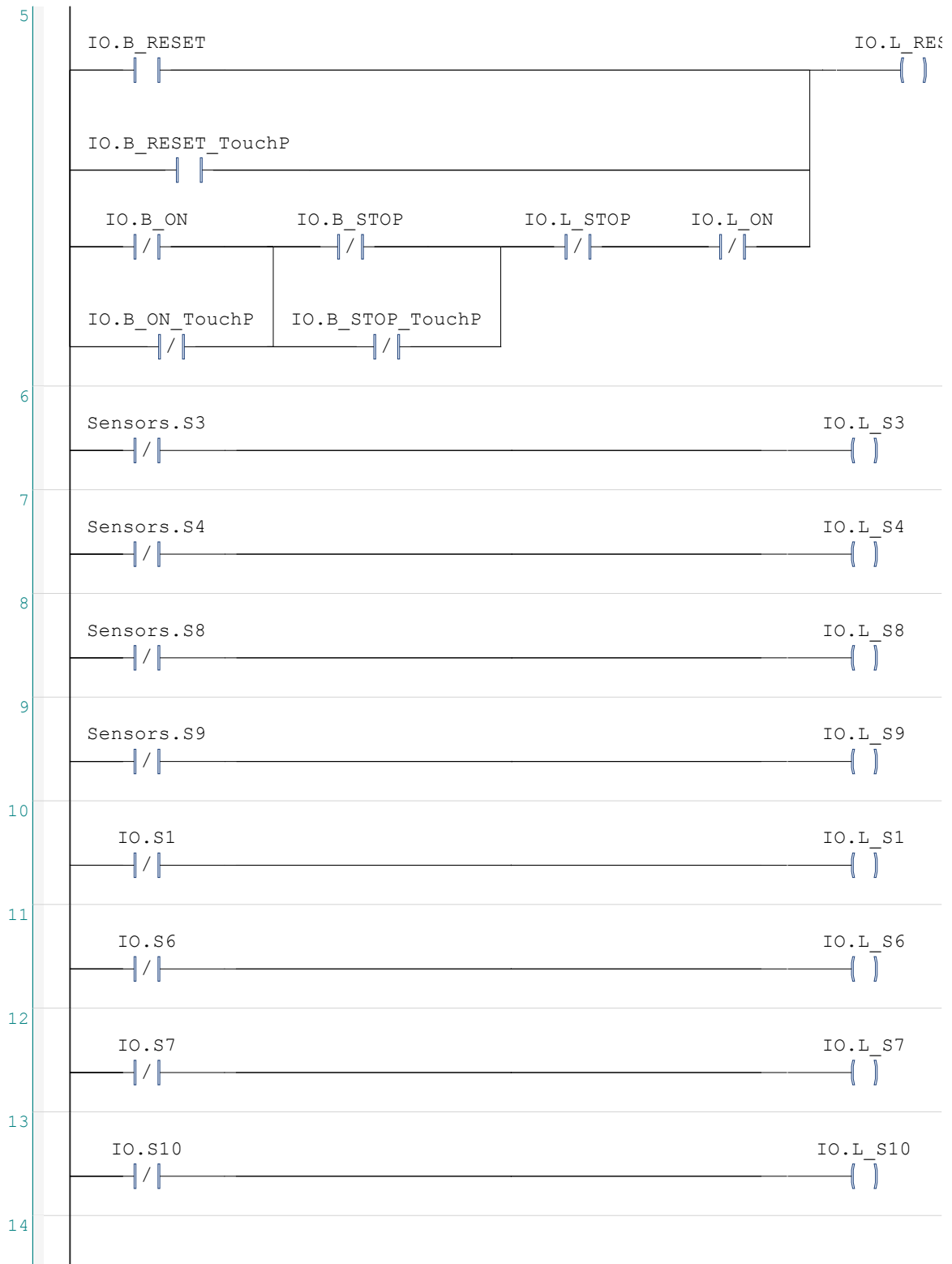

SET



CONFIGURATION

MARTA VIDAL ROMÁN

Would you like to delete the actual configuration?

Yes **No**

ZONA A	COLOUR	MATERIAL	MAGNETIC	
	lur	lur	lur	
ZONA B	COLOUR	MATERIAL	MAGNETIC	
	lur	lur	lur	

ROBOT	MANUAL/AUTO	RADIUS PIECES	%1.2f
NO	MANUAL	HEIGHT	%1.1f
		SPEED STEP MOTOR 1	%3.2f
YES	AUTO	SPEED STEP MOTOR 2	%3.2f
		SPEED DC MOTOR 2	%4.2f

	CONTROL	MANUAL MOVEMENTS	
--	---------	------------------	--

HAMK
HÄMEEN AMMATTIKORKEAKOULU
UNIVERSITY OF APPLIED SCIENCES

LOG IN/OUT

MARTA VIDAL ROMÁN

%s

Would you like to delete the actual configuration?

LOG IN

LOG OUT

CHANGE PASSWORD

USER ADMINISTRATION





WELCOME

Would you like to delete the actual configuration?

Yes

No

LOG IN/ OUT

CONFIGURATION

CONTROLS

MANUAL MOVEMENTS



HAMEEN AMMATTIKORKEAKOULU
UNIVERSITY OF APPLIED SCIENCES

MANUAL MOVEMENTS

MARTA VIDAL ROMÁN

CONVEYOR BELT 1



CONVEYOR BELT 2



Would you like to delete the actual configuration?

STEP MOTOR 1



STEP MOTOR 2



OPEN/CLOSE CLAMPS



RECIRCULATION



	CONTROL	CONFIGURACION	ALARMS
---	---------	---------------	--------

HAMK
HÄMEEN AMMATTIKORKEAKOULU
UNIVERSITY OF APPLIED SCIENCES

CONTROLS

MARTA VIDAL ROMÁN

Would you like to delete the actual configuration?

Yes No

CONFIGURATION DONE START STOP

ZONE A ZONE B

S1 S2-COLOUR S3-MATERIAL S4-MAGNETIC S5-DISTANCE
S6 S7 S8-MAGNETIC S9-MATERIAL S10

METAL OTHER METAL OTHER YES NO YES NO

SORTED ZONE A %3d SORTED ZONE B %3d
DELETED PIECES %3d RECIRCULATED PIECES %3d

CONFIGURATION MANUAL MOVEMENTS ALARMS