



Universidad de Valladolid



**ESCUELA DE INGENIERÍAS
INDUSTRIALES**

UNIVERSIDAD DE VALLADOLID

ESCUELA DE INGENIERIAS INDUSTRIALES

Grado en Ingeniería Mecánica

Design and fabrication of grips for tensile tests

Autor:

Camino Ferrero, Ignacio

Responsable de Intercambio en la UVa

Sánchez Báscones, M^a Isabel

Universidad de destino

Vives University College Kortrijk

Valladolid, junio de 2018.

TFG REALIZADO EN PROGRAMA DE INTERCAMBIO

TÍTULO: **Design and fabrication of grips for tensile tests**

ALUMNO: **Ignacio Camino Ferrero**

FECHA: **20 de junio de 2018**

CENTRO: **Vives University College Kortrijk**

TUTOR: **Tom Scharlaken**

Resumen

Este proyecto consiste en el diseño y fabricación de dos modelos de garras para una máquina de ensayo de tracción. En el apartado de diseño se muestran los cálculos realizados para verificar la resistencia de las garras. En el apartado de fabricación se enumeran los procesos necesarios para crear las garras.

Palabras clave

Garras, Mordazas, Diseño, Estructuras, Fabricación

Table of contents

1. Introduction	1
2. Goal	2
3. Calculations T-GRIPS.....	3
a. Load supported by the main bolts	3
b. Load supported by the pins.....	4
4. Calculations V-GRIPS	5
5. Common calculations.....	6
a. Anchorage	6
b. Anchorage pin	6
6. Manufacturing.....	8
a. T-GRIPS 1.0 and V-GRIPS 1.0	8
b. Manufacturing issues with the T-GRIPS 1.0	8
c. T-GRIPS 2.0.....	10
d. Manufacturing issues with the V-GRIPS.....	11
e. V-GRIPS 2.0.....	12
7. ANNEX A.....	13
8. ANNEX B	19
9. ANNEX C	25
10. ANNEX D.....	31
11. ANNEX E	37
12. ANNEX F.....	43

1. Introduction

The tensile strength testing of different material samples is vital in the engineering process in order to achieve the best possible quality in the final product, as well as improve the manufacturing process. The grips used for this test are divided in different categories (vise grips, wedge grips, pneumatic grips, self-centering grips...) according to the gripping method, the actuator or some other characteristics.

Maaklab count with a tensile strength testing machine that can be seen in the right picture.

This testing machine can perform tensile strength test up to 30 kN.

The samples used for the testing usually have a shape defined by normative. This machine is designed to test from plastic samples to soft metal specimens, including fibers and textiles. An example of this samples can be seen in the picture below.



Plastic sample



Testing machine

2. Goal

This project is focused in the design and manufacturing of manual vise grips (parallel gripping method) using different CAD and CAM software. After performing the required calculations the designed grips are able to withstand strength testing up to 30 kN, which allows the testing of all kinds of plastic and fibers, as well as some soft metals like aluminium.

These grips will replace the previous ones, which presented several difficulties to hold the samples. As it can be seen in the picture below these grips were wedge type grips with a self-tightening mechanism which does not work properly anymore.

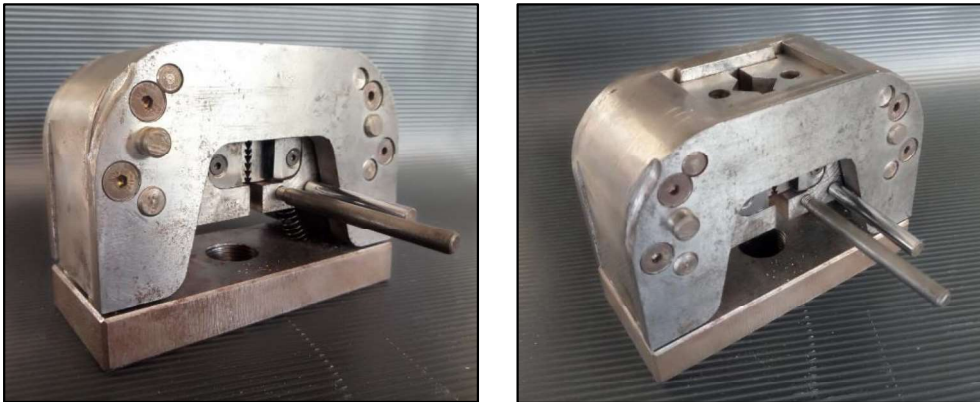

Previous Wedge grips

In order to achieve the best design possible two different sets of grips were made, one by each one of us. This way of designing allows the team to see more clearly the difficulties related to manufacturing, assembly and operation with the aim of reaching the best possible final product. From now on the grips designed by Ignacio Camino Ferrero will be referenced as T-GRIPS and the ones designed by Antonio Blanco Casares will be referenced as V-GRIPS.

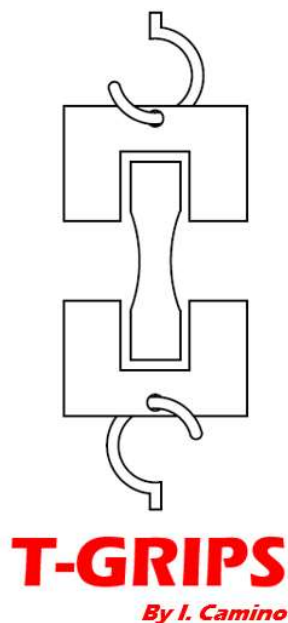

3. Calculations T-GRIPS

The calculations described below show the required dimensions of the components of the grip according to the part that holds the load.

a. Load supported by the main bolts

The whole load (30 kN) will be supported by the main bolts, so each one of them is going to support 15 kN. Considering 8.8 grade for the bolts, meaning an ultimate material strength of 800 N/mm² and 640 N/mm² minimum proof strength, the maximum momentum supported by the bolt will be:

$$M_{\max} = 22,5 \cdot 10^{-3} \text{ m} \cdot 15000 \text{ N} = 337,5 \text{ Nm}$$

$$\sigma_{\max} = 640 \text{ MPa} = (337,5 \text{ Nm} \cdot R_{\min}) / (\pi \cdot (R_{\min})^4 \cdot 0,25)$$

$$R_{\min} = (337,5 \text{ Nm} / (\pi \cdot 640 \cdot 10^6 \text{ N/m}^2 \cdot 0,25))^{1/3} = 0,00876 \text{ m}$$

$$\varnothing_{\min} = 0,0175 \text{ m} = 17,5 \text{ mm}$$

We need at least 17,5 mm diameter in each bolt to hold the 30 kN load with a 45 mm clearance.

The maximum and minimum diameters of metric bolts can be seen in the chart below.

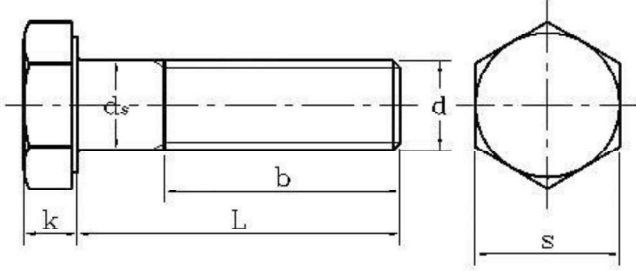

Unit: mm

d	P	b			d _s		k		s	
		L < 125	125 < L < 200	200 < L	max	min	max	min	max	min
M5	0.8	16	22	35	5.48	4.52	3.875	3.125	8	7.64
M6	1	18	24	37	6.48	5.52	4.375	3.625	10	9.64
M8	1.25	22	28	41	8.58	7.42	5.675	4.925	13	12.57
M10	1.5	26	32	45	10.58	9.42	6.85	5.95	16	15.57
M12	1.75	30	36	49	12.70	11.30	7.95	7.05	18	17.57
M14	2	34	40	53	14.70	13.30	9.25	8.35	21	20.16
M16	2	38	44	57	16.70	15.30	10.75	9.25	24	23.16
M18	2.5	42	48	61	18.70	17.30	12.40	10.60	27	26.16
M20	2.5	46	52	65	20.84	19.16	13.40	11.60	30	29.16
M22	2.5	50	56	69	22.84	21.16	14.90	13.10	34	33

Metric bolt size chart

With M18 bolts it should be enough but in order to stay inside the safe zone the final choice will be M20.

b. Load supported by the pins

The whole load (30 kN) will be supported by the four cylindrical pins ($\varnothing 10$), so each one of them is going to support 7,5 kN. Considering 8.8 grade for the pins, meaning an ultimate material strength of 800 N/mm^2 and 640 N/mm^2 minimum proof strength, the maximum momentum supported by the pin will be:

$$M_{\max} = 22,5 \cdot 10^{-3} \text{ m} \cdot 7500 \text{ N} = 168,75 \text{ Nm}$$

The inertia of the pen:

$$I = \pi \cdot (5 \cdot 10^{-3} \text{ m})^4 \cdot 0,25 = 4,9087 \cdot 10^{-10} \text{ m}^4$$

And finally, the maximum stress supported by the pen is:

$$\sigma_{\max} = (168,75 \text{ Nm} \cdot 5 \cdot 10^{-3} \text{ m}) / 4,9087 \cdot 10^{-10} \text{ m}^4 = 1,7189 \cdot 10^9 \text{ N/m}^2 = 1718,9 \text{ MPa}$$

The minimum proof strength of the pen is 640 MPa so it will plastify under this load. We have to increase the pen diameter to avoid plastification.

$$\sigma_{\max} = 640 \text{ MPa} = (168,75 \text{ Nm} \cdot R_{\min}) / (\pi \cdot (R_{\min})^4 \cdot 0,25)$$

$$R_{\min} = (168,75 \text{ Nm} / (\pi \cdot 640 \cdot 10^6 \text{ N/m}^2 \cdot 0,25))^{1/3} = 0,00695 \text{ m}$$

$$\varnothing_{\min} = 0,0139 \text{ m} = 13,9 \text{ mm}$$

We need at least 13,9 mm of diameter if we want the four pens (8.8) to hold the 30 kN load without plastifying with a clearance of 45 mm.

This diameter could be reduced diminishing the clearance of the grip. The minimum diameter required for different clearances can be seen in the following table.

Clearance (mm)	\varnothing_{\min} (mm)
45	13,9
40	13,36
38	13,1
36	12,9
35	12,8
34	12,66

Choosing the 45mm clearance the grips in the open and close position would look like shown in the drawings below.

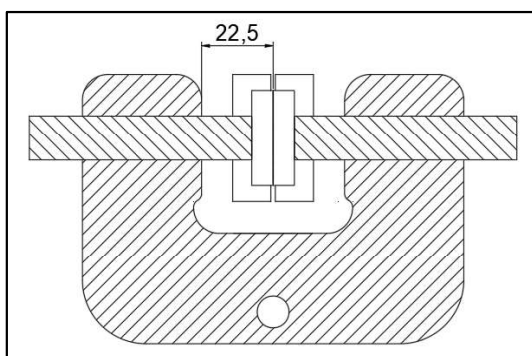

Closed jaws

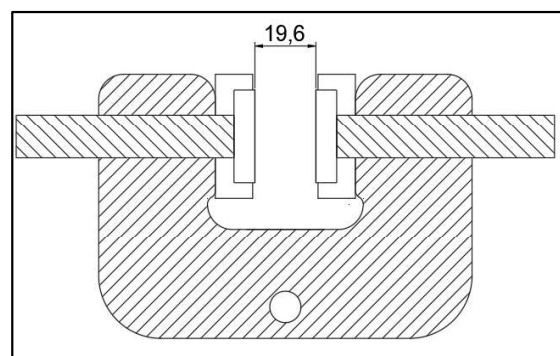

Open jaws

4. Calculations V-GRIPS

We have use bolts M20 8.8 with normal pitch, we use the inward diameter for the study. The maximum load is 30KN:

Bolts M20 $\rightarrow d = 16,53\text{mm} \rightarrow A = \frac{\pi \cdot d^2}{4} = 214,6 \text{ mm}^2 = 2,146 \cdot 10^{-4} \text{ m}^2$

$$I_z = \frac{\pi \cdot d^4}{64} = 3664,89 \text{ mm}^4 = 3,6649 \cdot 10^{-9} \text{ m}^4$$

Quality 8.8 $\rightarrow \sigma_{max} = 640 \text{ MPa}$

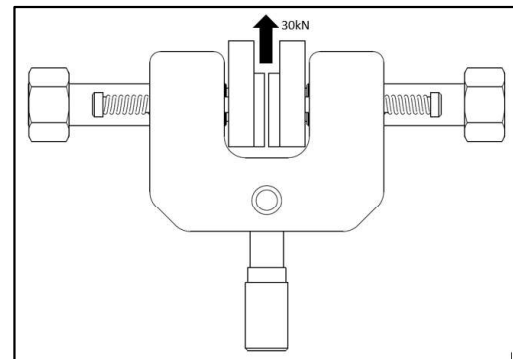
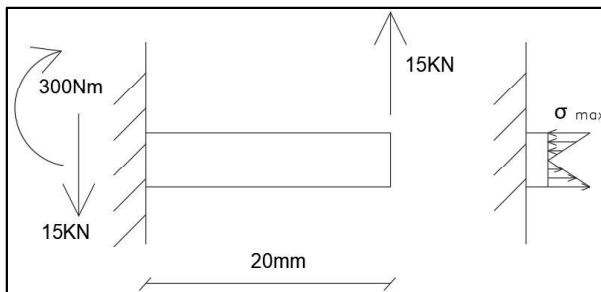
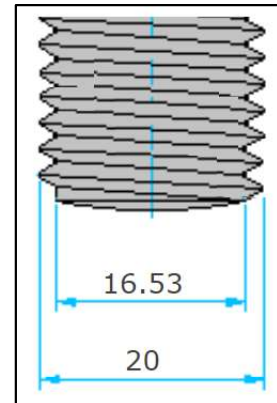

$$\sigma_{max} = \frac{M \cdot R}{I_z} = \frac{300 \cdot 8,265 \cdot 10^{-3}}{3,6649 \cdot 10^{-9}} = 676.553.000 \text{ Pa} = 676,553 \text{ MPa}$$

If we want to load 30KN we need stronger bolts, the minimum diameter is calculated:

$$\sigma_{max} = 640 \text{ MPa} = \frac{M \cdot R}{I_z} = \frac{M \cdot d}{I_z \cdot 2} = \frac{M \cdot d}{\frac{\pi \cdot d^4}{64} \cdot 2} = \frac{32 \cdot M}{\pi \cdot d^3}$$

$$d = \sqrt[3]{\frac{32 \cdot M}{\pi \cdot 640 \text{ MPa}}} = 0,0168 \text{ m} = 16,8 \text{ mm}$$

The inward diameter has to be bigger than 16,8. In the final design we will use M24 $\rightarrow d=19,83\text{mm}$

5. Common calculations

a. Anchorage

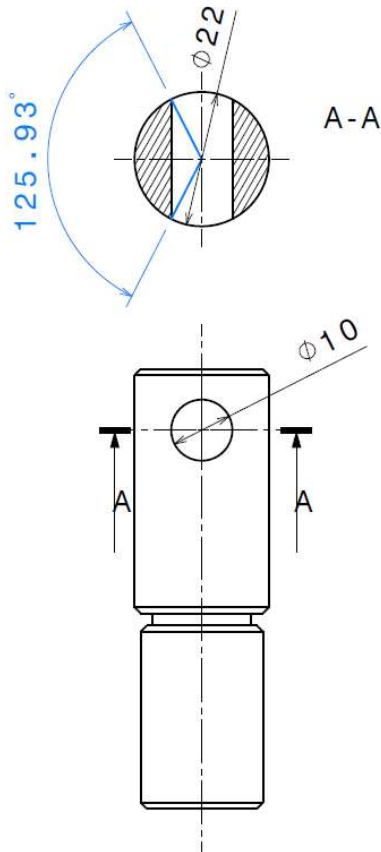

$$\begin{aligned}
 \text{Area} &= \\
 &= 2 \cdot (\text{Circular sector area} - \text{Triangle area}) = \\
 &= 2 \cdot \left(\pi \cdot r^2 \cdot \frac{\alpha}{360^\circ} - \frac{r^2 \cdot \sin \alpha}{2} \right) = \\
 &= 2 \cdot r^2 \left(\pi \cdot \frac{\alpha}{360} - \frac{\sin \alpha}{2} \right) = \\
 &= 2 \cdot 11^2 \left(\pi \cdot \frac{125,93}{360} - \frac{\sin 125,93}{2} \right) = 167,97 \text{ mm}^2
 \end{aligned}$$

$$\text{Stress } \sigma = \frac{30 \text{ kN}}{167,97 \text{ mm}^2} = 0,1786 \cdot \frac{10^9 \text{ N}}{\text{m}^2} = 178,6 \text{ MPa}$$

Our part is made of a threaded bar which is normal steel.
The yield strength is 210 MPa.

$$\text{Security factor} = \frac{210}{178,6} = 1,18$$

b. Anchorage pin

For the pin that anchors the grip to the table the calculations will be made using a software based on the Direct Stiffness Method, since this calculation requires more complex equations to describe accurately the behavior of the pin.

Pin: $\varnothing 10$, Anchorage hole: $\varnothing 22$

The software shows that under the 30 kN load the pin reaches in some of its points a maximum of 55 Nm with the fixed supports and 82,5 Nm with the rotation freedom supports, therefore:

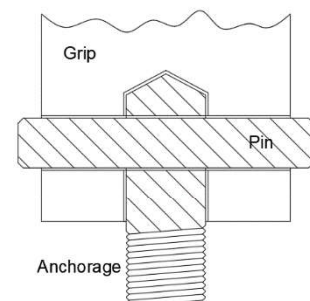

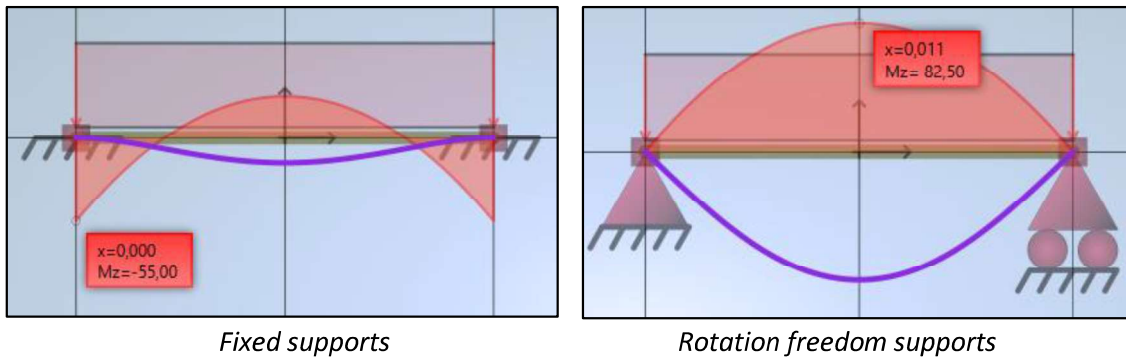

$$\sigma_{\max 1} = (55 \text{ Nm} \cdot 5 \cdot 10^{-3} \text{ m}) / 4,9087 \cdot 10^{-10} \text{ m}^4 = 5,60 \cdot 10^8 \text{ N/m}^2 = 560 \text{ MPa}$$

$$\sigma_{\max 2} = (82,5 \text{ Nm} \cdot 5 \cdot 10^{-3} \text{ m}) / 4,9087 \cdot 10^{-10} \text{ m}^4 = 8,40 \cdot 10^8 \text{ N/m}^2 = 840 \text{ MPa}$$

The pin has little space for rotation but it is not completely fixed so the maximum tension will be between the 407,4 MPa and 611,2 MPa. Since the yield strength for the pin (grad 10.9) is 940 MPa we can assure that it is not going to plastify during the 30 kN testing.

6. Manufacturing

a. T-GRIPS 1.0 and V-GRIPS 1.0

For the first version of both grip designs the main bolts will take all the load, so the pins will only be there to straighten the jaws.

The drawings of this version as it was designed, with the required tolerances and dimensions, can be seen in *Annex A* and *Annex D*.

Manufacturing process:

Operation	Machine
Cutting basic shape of the grip	Water jet cutting machine
Drilling and chamfering required holes in the grip	Milling machine
Cutting the 2 jaws out of steel bar (50x15mm)	Sewing machine
Milling the 2 jaws till the required thickness (12mm)	Milling machine
Drilling and chamfering the required holes in the jaws	Milling machine
Welding file pieces to the jaws gripping surface	MIG welder
Turning the main bolts	Lathe machine
Welding nuts to the main bolts	MIG welder
Turning the anchorage till $\varnothing 15,9$	Lathe machine
Drilling the anchorage	Milling machine

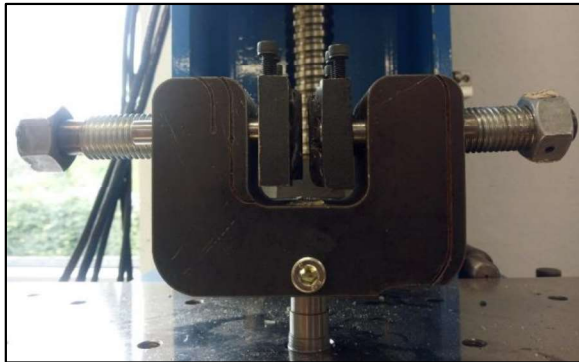

T-GRIPS 1.0



V-GRIPS 1.0

b. Manufacturing issues with the T-GRIPS 1.0

During the manufacture of all the parts in the workshop some problems arose. These issues are enlisted here below.

-Difficulty to drill the grip holes straight enough, causing the main bolt tip to be thinner in order to assemble properly. This issue is probably caused by the water jet cut of the main shape, which does not achieve a totally straight surface.

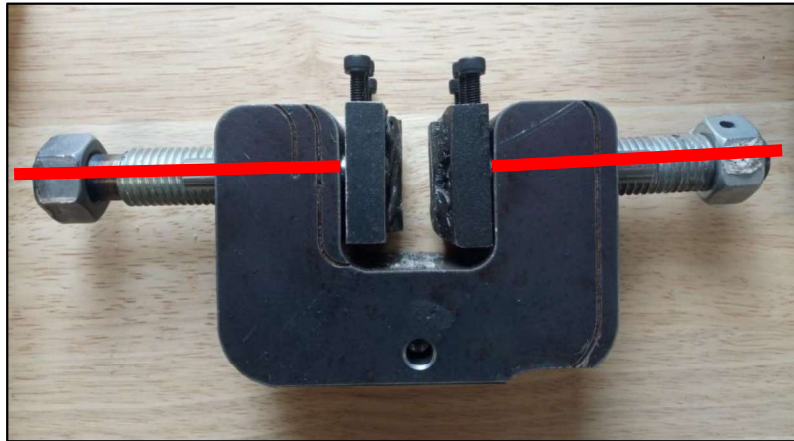

Deviation of the main bolts

-The welding of the file piece to the jaw left the gripping surface of the file almost without any embossment, and therefore, not enough friction power to grip the samples.



Damaged gripping surface

-The welding of the nut broke after some uses, leaving the user unable to tighten the main bolt.



Welded nut

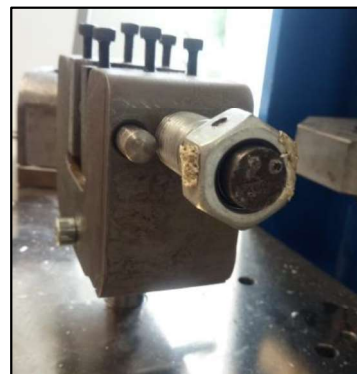

Broken weld

The drawings of the grip as it was built can be seen in *Annex B*.

c. T-GRIPS 2.0

Some changes had to be made in order to correct the issues gotten with the first version.

In this second version the whole load is going to be taken by the four pins, therefore, the main bolts are only going to be there to grip the sample.

Since the whole load is taken by the pins, the main bolt can be an M12 bolt, making the nut welding unnecessary.

The jaws are going to have exchangeable gripping surfaces so when they run out of embossment there will be no need to manufacture a new jaw, only to cut another piece of file and assemble it to the existing part.

The outer surfaces of the grip body will be milled after the water jet cutting, making them parallel enough to ensure that after the drilling the holes are straight enough.

The drawings of this version as it was designed, with the required tolerances and dimensions, can be seen in *Annex C*.

Manufacturing process:

Operation	Machine
Cutting basic shape of the grip	Water jet cutting machine
Milling outer surfaces of the grip	Milling machine
Drilling and chamfering required holes in the grip	Milling machine
Cutting the 2 jaws out of steel bar (50x15mm)	Sewing machine
Milling the 2 jaws till the required thickness (12mm)	Milling machine
Milling the slots required in the 2 jaws	Milling machine
Drilling and chamfering the required holes in the jaws	Milling machine
Cutting file pieces for the jaws gripping surface	Sewing machine
Turning the main bolts	Lathe machine
Turning the anchorage	Lathe machine
Drilling the anchorage	Milling machine

The second version of the T-GRIPS can be seen in the 3D model shown below.

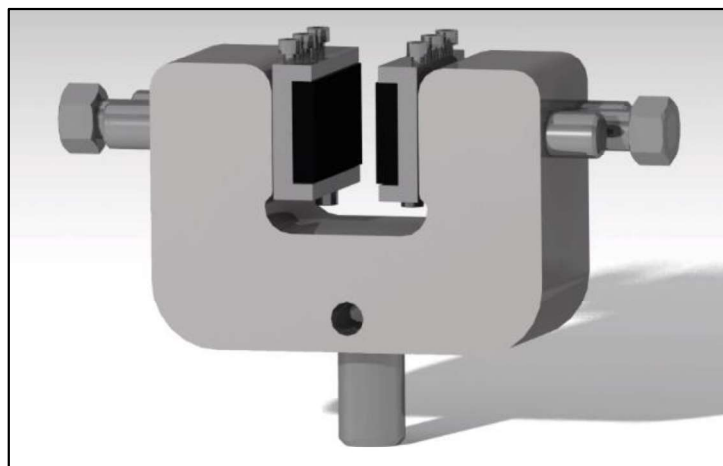

T-GRIPS 2.0

The drawings of this last design can be seen in *Annex C*.

d. Manufacturing issues with the V-GRIPS

These are the issues of the grips related to the manufacturing process:

- The holes are not straight, it is because the outwards faces are not flat, in the new version we will solve it milling those faces.
- We decided to weld files after starting the manufacturing. The files are too thick, and the slot between the jaws is too small.
- The corner below of the jaw collides with the round edge of the grip body

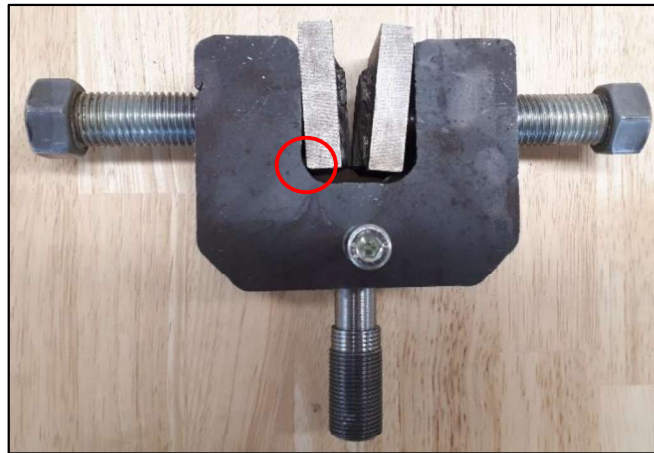

- The side holes are not through the part, therefore they are not deep enough to make the thread properly.
- The holes are not in the center of the jaw.



- One of the central bolts is not tight enough into the jaw, it is because the tip of the bolt has less diameter than the required.



- During the manufacture process we decided to weld a nut in the central bolts, instead of using a pin as a fastener, the problem is that there is no space to insert the sides bolts.

The drawings of the grip as it was built can be seen in *Annex E*.

e. V-GRIPS 2.0

This version has the following changes:

The outwards surfaces are milled to make the holes straight.

A slot is milled in the jaw. The files are inserted in this slot.

The holes of the jaw are in the centre and go through the part.

In the central bolts, pins are used as fasteners instead of the welded nuts.

Manufacturing process:

Operation	Machine
Cutting basic shape of the grip	Water jet cutting machine
Milling outer surfaces of the grip	Milling machine
Drilling and chamfering required holes in the grip	Milling machine
Cutting the 2 jaws out of steel bar (50x15mm)	Sewing machine
Milling the 2 jaws till the required thickness	Milling machine
Milling the slots required in the 2 jaws	Milling machine
Joining the files to the jaws	MIG welding
Drilling and chamfering the required holes in the jaws	Milling machine
Cutting file pieces for the jaws gripping surface	Sewing machine
Turning the main bolts	Lathe machine
Turning the anchorage	Lathe machine
Drilling the anchorage	Milling machine

The second version of the T-GRIPS can be seen in the 3D model shown below.

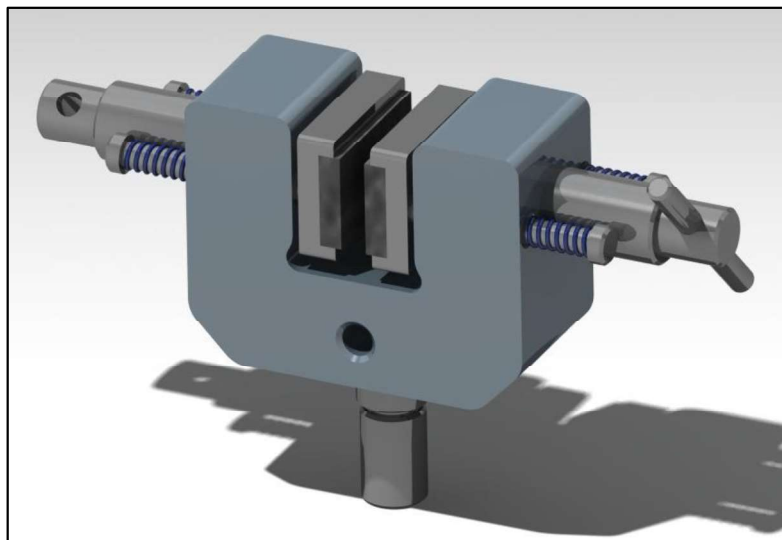

V-GRPS 2.0

The drawings of this last design can be seen in *Annex F*.

7. ANNEX A

T-GRIP 1.0 Drawings

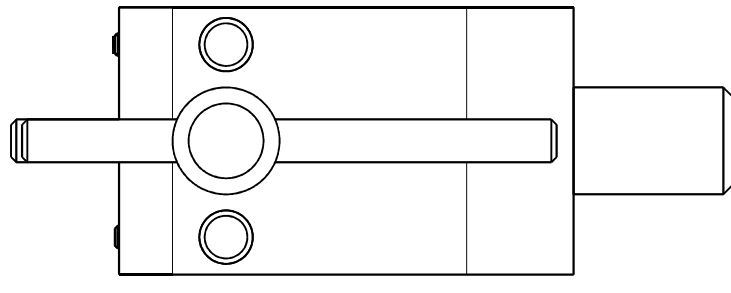
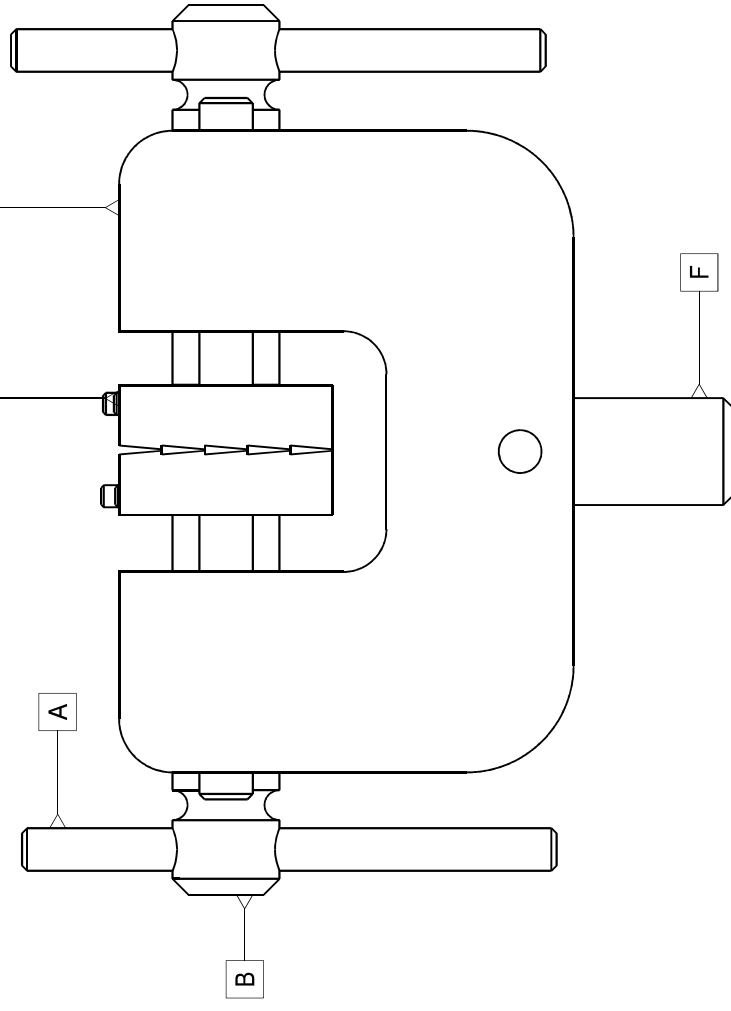

A	Fastener
B	Main Screw
C	Grip Body
D	Jaw
E	Straightener
F	Anchorage

This drawing is our property.
It can't be reproduced
or communicated without
our written agreement.

DRAWN BY	DATE
I. Camino	21/03/2018
CHECKED BY	DATE
XXX	xxx
DESIGNED BY	DATE
XXX	xxx

STRENGTH TESTING GRIP

DRAWING TITLE	
Vise Grip	
SIZE	DRAWING NUMBER
A3	MountedGrip
SCALE	1:1 WEIGHT (kg) 0,24

REV	X
SHEET	1/1

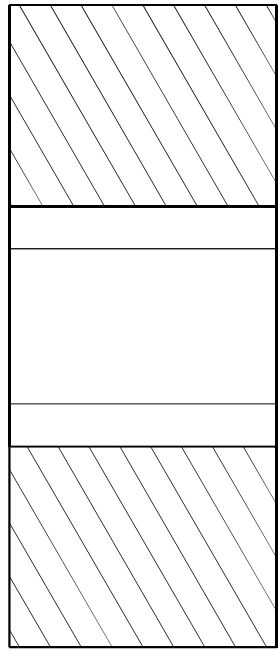
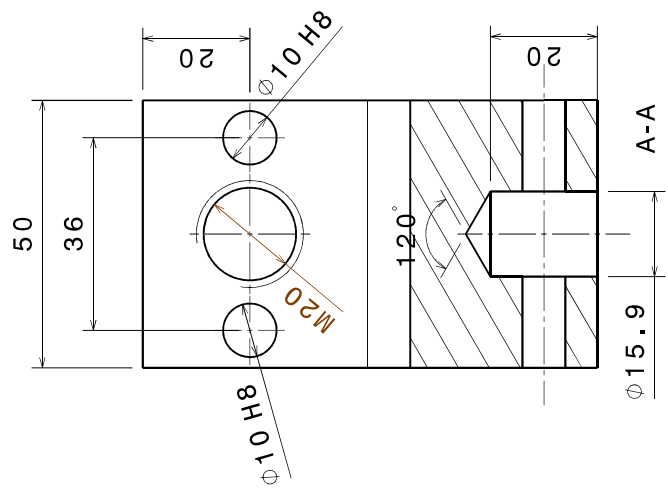

This drawing is our property.
It can't be reproduced
or communicated without
our written agreement.

STRENGTH TESTING GRIP

DRAWN BY I. Camino		DATE 21/03/2018		DRAWING TITLE Grip Body	
CHECKED BY XXX		DATE xxx		SIZE A3	
DESIGNED BY XXX		DATE xxx		DRAWING NUMBER Grip Body	
		SCALE 1:1		WEIGHT (kg) 0,16	
				SHEET 1/1	

4 3 2 1

α

γ

δ

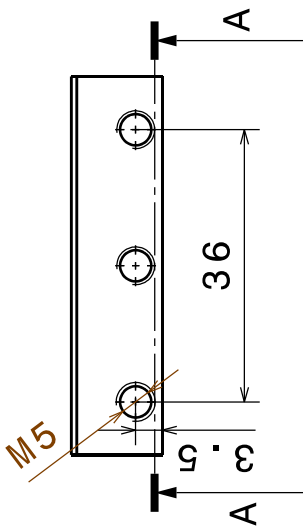
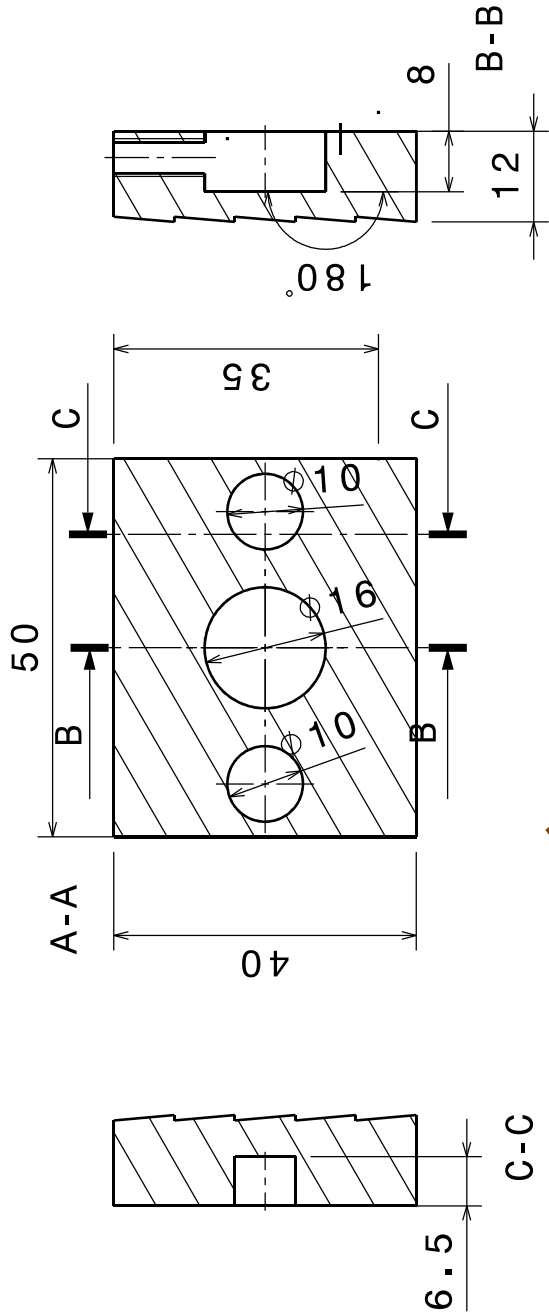

This drawing is our property.
It can't be reproduced
or communicated without
our written agreement.

STRENGTH TESTING GRIP

DRAWING TITLE

Jaw

DRAWN BY
I. Camino

DATE
21/03/2018

CHECKED BY
XXX

DATE
XXX

DESIGNED BY
XXX

DATE
XXX

SIZE
A4

REV
X

Jaw

SCALE 1:1 WEIGHT (kg) 0,02

SHEET 1/1

A

D

4 3 2 1

4

∞

C

D

4

4

3

3

2

2

1

1

D

A

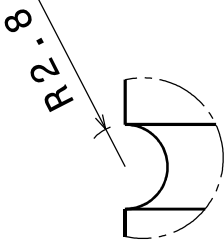
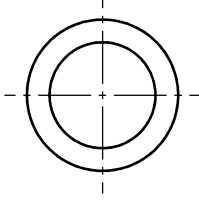
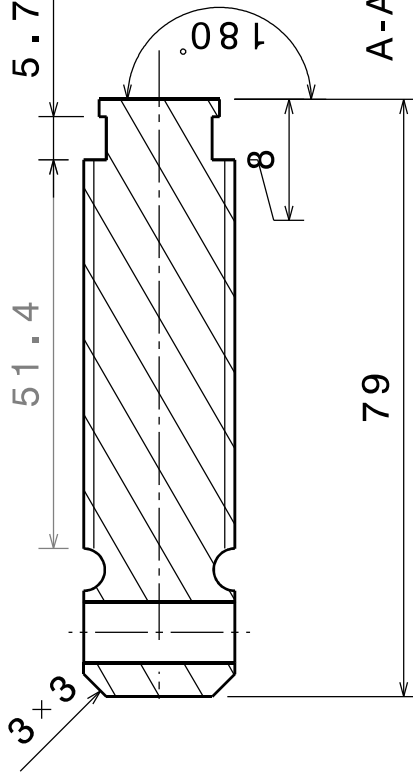
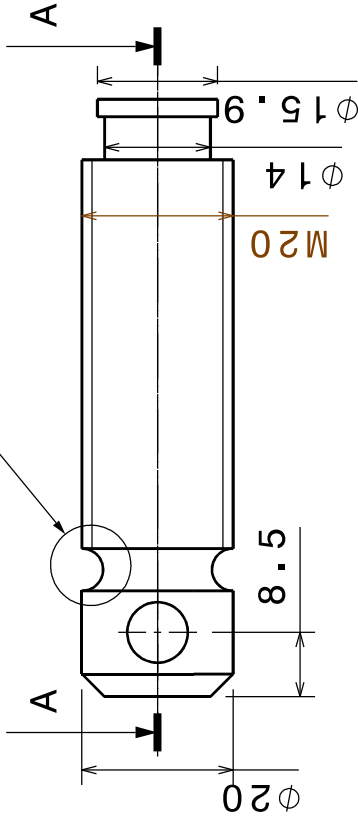

Detail B
Scale: 2:1

This drawing is our property.
It can't be reproduced
or communicated without
our written agreement.

STRENGTH TESTING GRIP

DRAWING TITLE

MainScrew

DRAWN BY
I. Camino

DATE
21/03/2018

CHECKED BY
XXX

DATE
xxx

DESIGNED BY
XXX

DATE
xxx

SIZE
A4

DRAWING NUMBER
MainScrew

REV
X

SCALE
1:1

WEIGHT (kg)
0,01

SHEET
1/1

4 3 2 1

∞

∞

∞

A

D

A

D

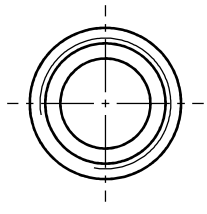
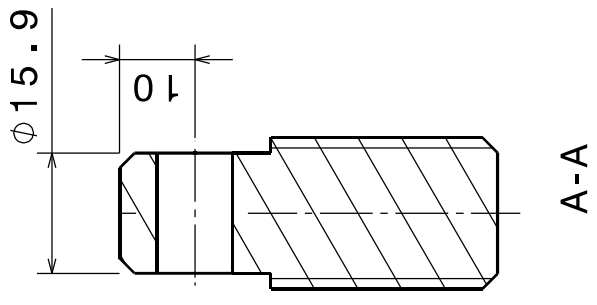
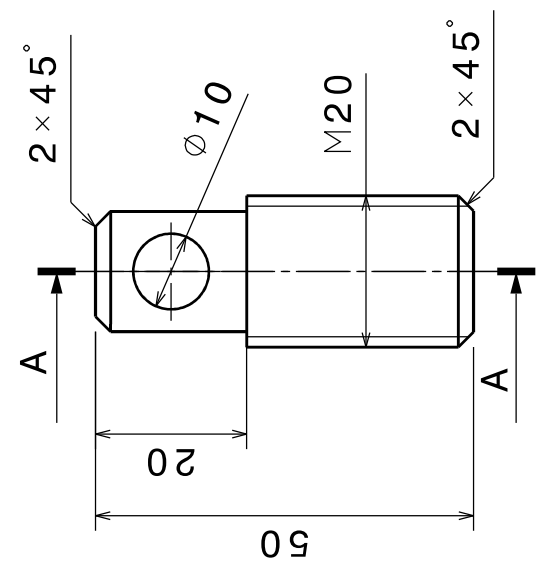

This drawing is our property.
It can't be reproduced
or communicated without
our written agreement.

STRENGTH TESTING GRIP

DRAWING TITLE

DRAWN BY	DATE
I. Camino	21/03/2018
CHECKED BY	DATE
T. Scharlaken	21/03/2018
DESIGNED BY	DATE
I. Camino	21/03/2018

Anchorage

SIZE	DRAWING NUMBER	REV
A4	5	0

SCALE	1:1	WEIGHT (kg)	0,085	SHEET	1/1
-------	-----	-------------	-------	-------	-----

A

D

4

3

2

1

8. ANNEX B

T-GRIP 1.0 Drawings “As built”

4

3

2

1

4

3

2

1

A

B

C

E

D

A	Main Screw
B	Grip Body
C	Jaw
D	Straightener
E	Anchorage

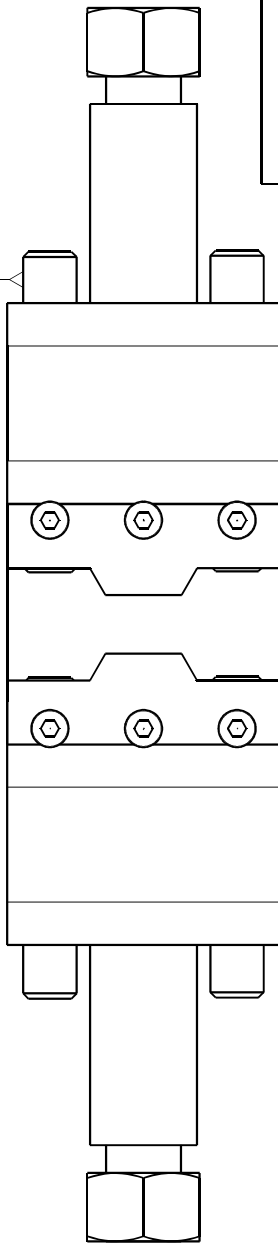
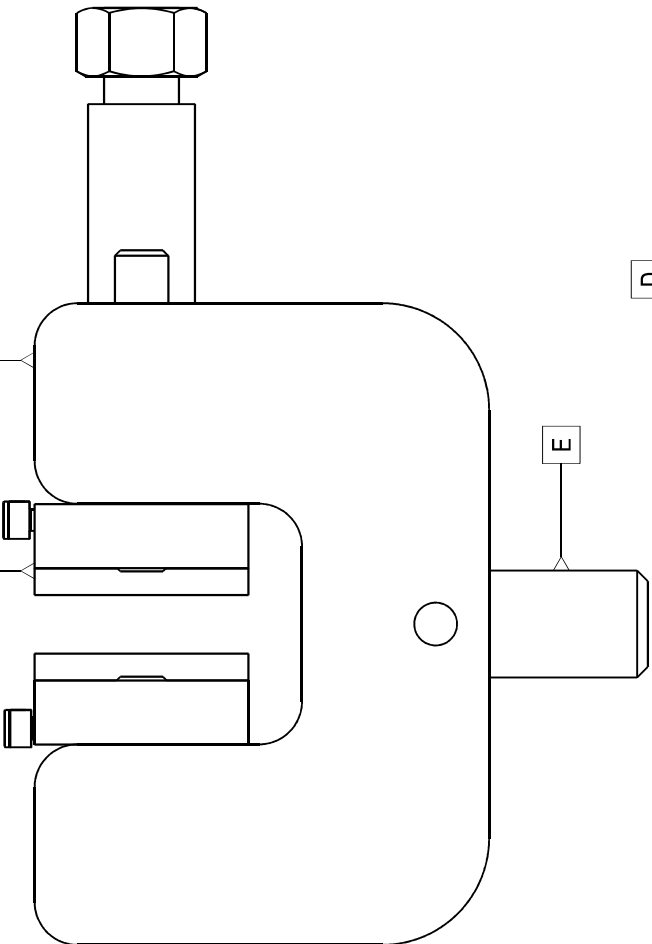
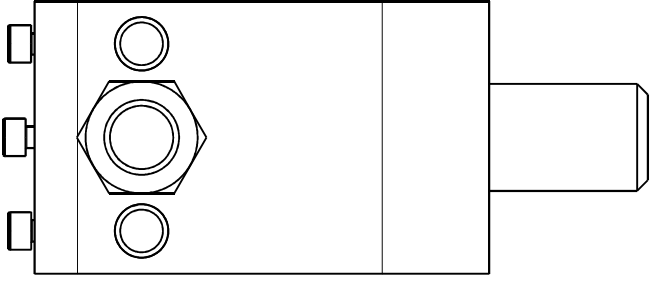

This drawing is our property.
It can't be reproduced
or communicated without
our written agreement.

DRAWN BY	DATE
I. Camino	16/04/2018
CHECKED BY	DATE
T. Scharlaken	16/04/2018
DESIGNED BY	DATE
I. Camino	16/04/2018

STRENGTH TESTING GRIP

DRAWING TITLE

Vise Grip

SIZE	DRAWING NUMBER	REV			
A3	1	0			
SCALE	1:1	WEIGHT (kg)	4,23	SHEET	1/1

H

G

F

E

D

C

B

A

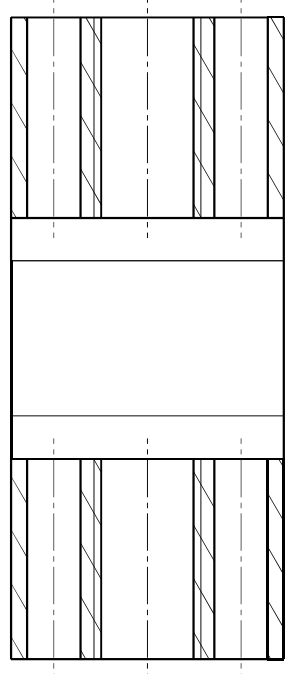
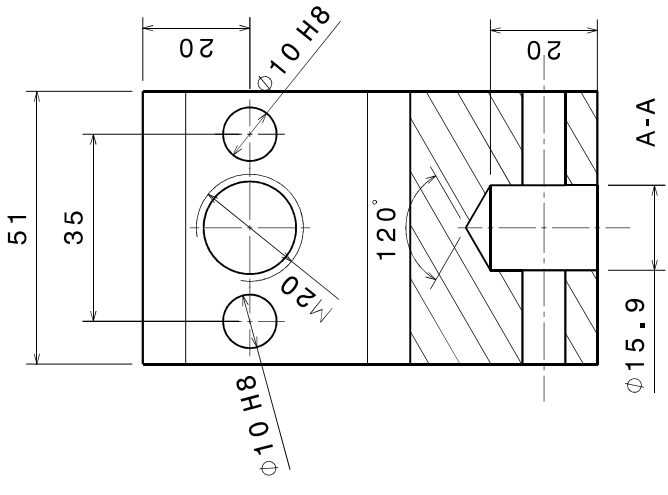
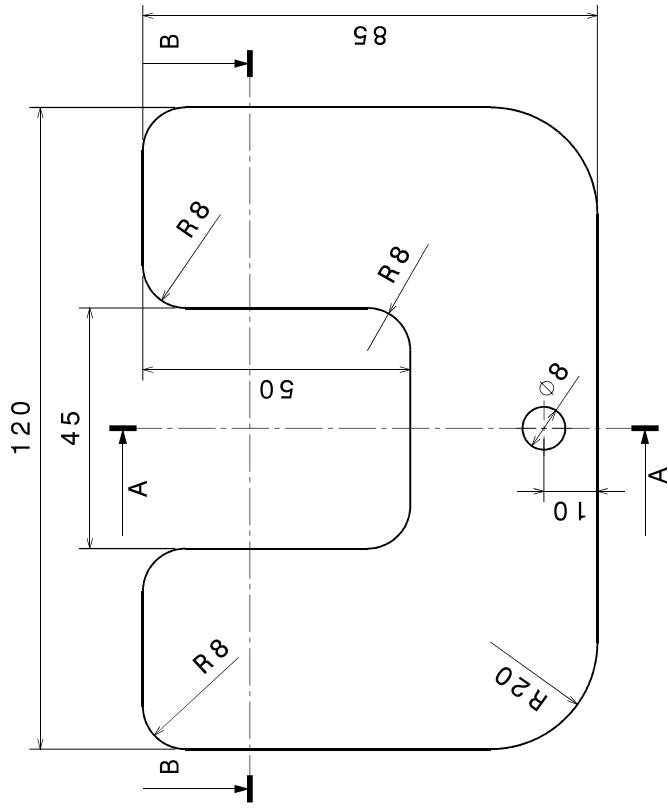

This drawing is our property.
It can't be reproduced
or communicated without
our written agreement.

STRENGTH TESTING GRIP

DRAWN BY I. Camino		DATE 16/04/2018	DRAWING TITLE Grip Body	
CHECKED BY T. Scharlaken		DATE 16/04/2018	SIZE A3	DRAWING NUMBER 2
DESIGNED BY I. Camino		DATE 16/04/2018	SCALE 1:1	WEIGHT (kg) 3,85
			SHEET 1/1	

B-B

4 3 2 1

α

γ

δ

Α

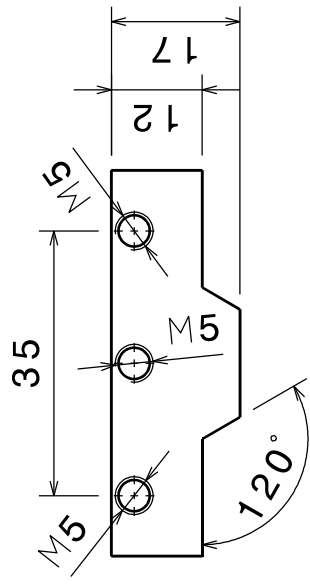
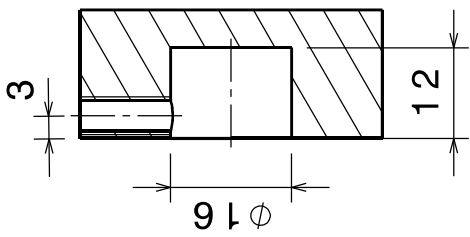
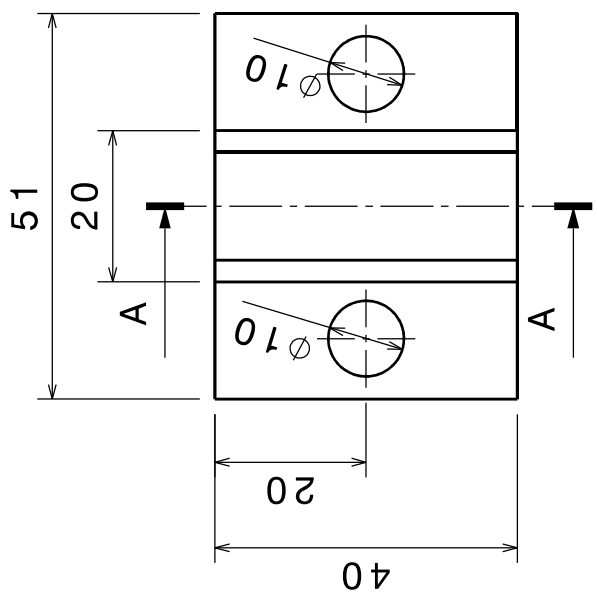

This drawing is our property.
It can't be reproduced
or communicated without
our written agreement.

STRENGTH TESTING GRIP

DRAWING TITLE

DRAWN BY	DATE
I. Camino	16/04/2018
CHECKED BY	DATE
T. Scharlaken	16/04/2018
DESIGNED BY	DATE
I. Camino	16/04/2018

Jaw

SIZE	DRAWING NUMBER	REV
A4	3	0

SCALE	1:1	WEIGHT (kg)	0,25	SHEET	1/1
-------	-----	-------------	------	-------	-----

4 3 2 1

δ

γ

α

Α

4 3 2 1

A

B

C

D

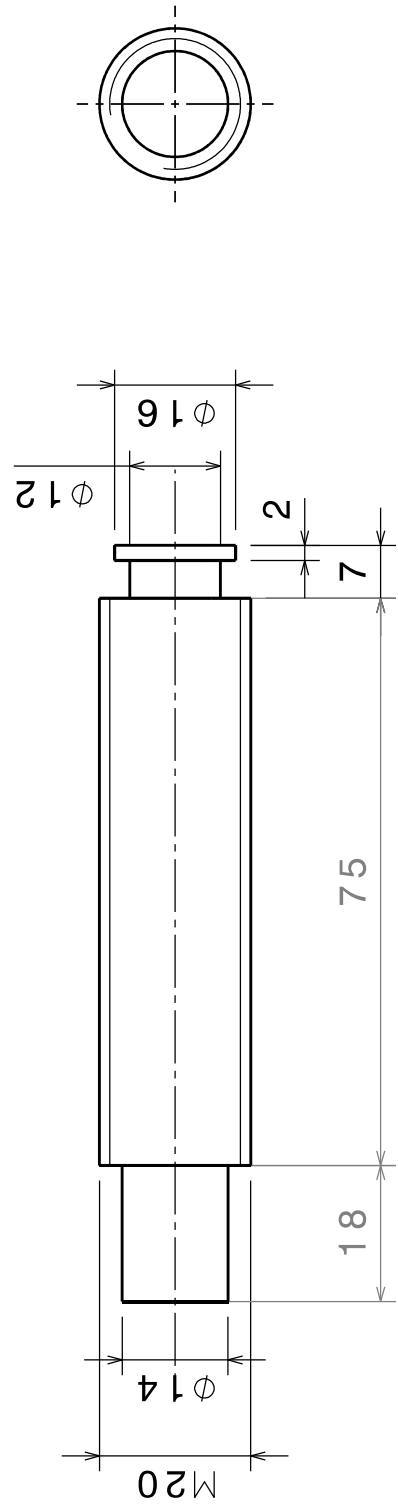

This drawing is our property.
It can't be reproduced
or communicated without
our written agreement.

STRENGTH TESTING GRIP

DRAWING TITLE

Main Bolt

DRAWN BY	DATE
I. Camino	16/04/2018
CHECKED BY	DATE
T. Scharlaken	16/04/2018
DESIGNED BY	DATE
I. Camino	16/04/2018

SIZE	DRAWING NUMBER	REV
A4	4	0

SCALE	1:1	WEIGHT (kg)	0,32	SHEET	1/1
-------	-----	-------------	------	-------	-----

4 3 2 1

A

D

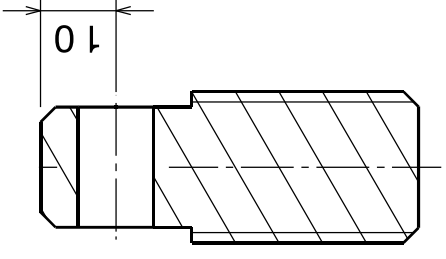
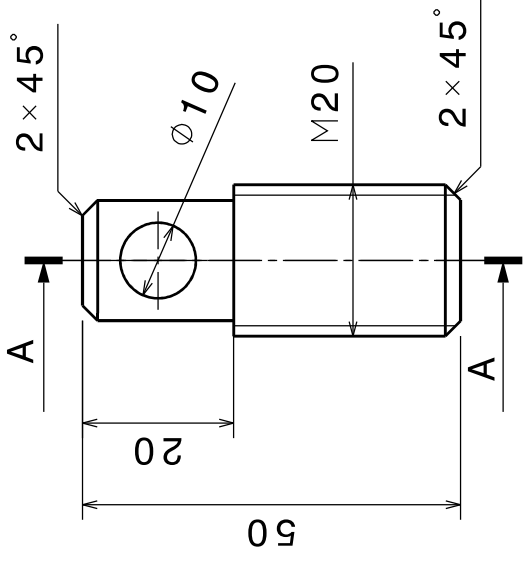

A-A

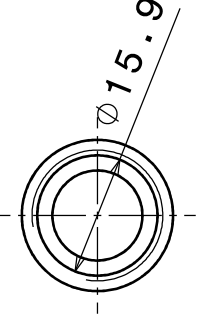

This drawing is our property.
It can't be reproduced
or communicated without
our written agreement.

DRAWN BY	DATE
I. Camino	16/04/2018
CHECKED BY	DATE
T. Scharlaken	16/04/2018
DESIGNED BY	DATE
I. Camino	16/04/2018

STRENGTH TESTING GRIP

DRAWING TITLE

Anchorage

SIZE	DRAWING NUMBER	REV
A4	5	0

SCALE	1:1	WEIGHT (kg)	0,085	SHEET	1/1
-------	-----	-------------	-------	-------	-----

A

B

C

D

4

3

2

1

A

D

4

3

2

1

9. ANNEX C

T-GRIP 2.0 Drawings

A

D

C

B

E

A	Grip body
B	Anchorage
C	Main bolt
D	Jaw
E	Straightener

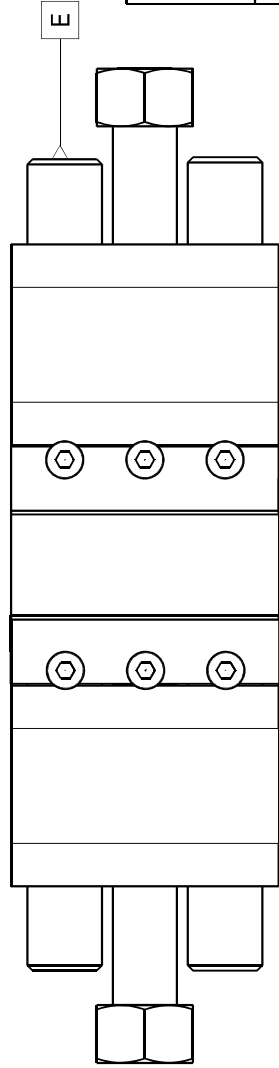
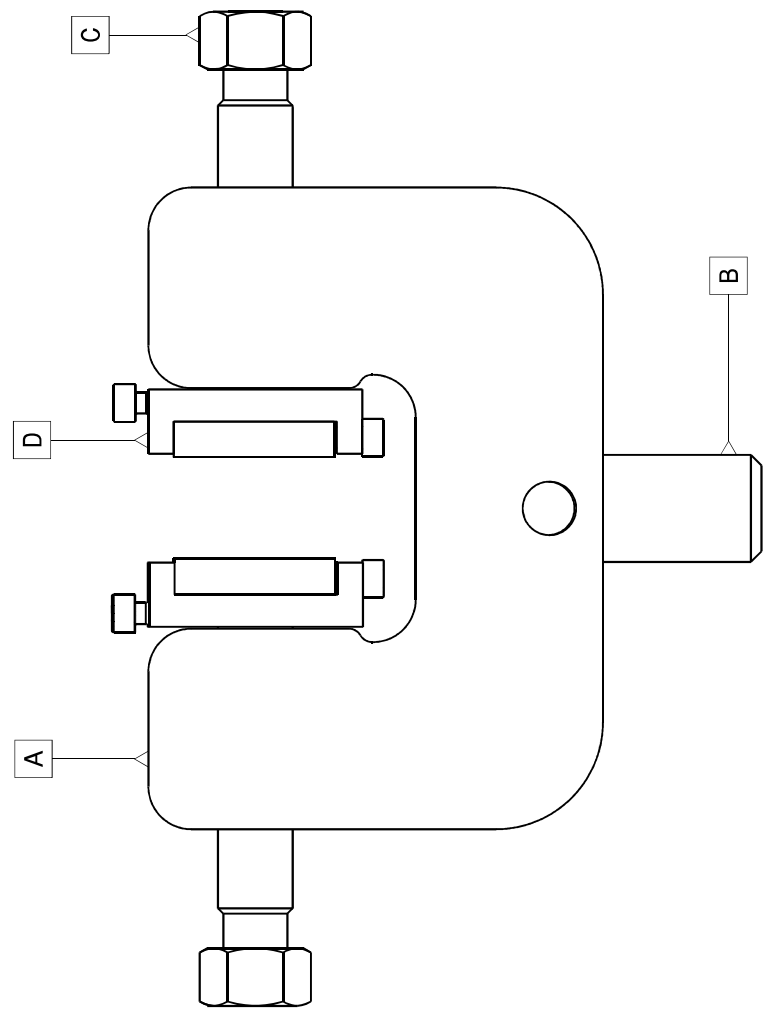
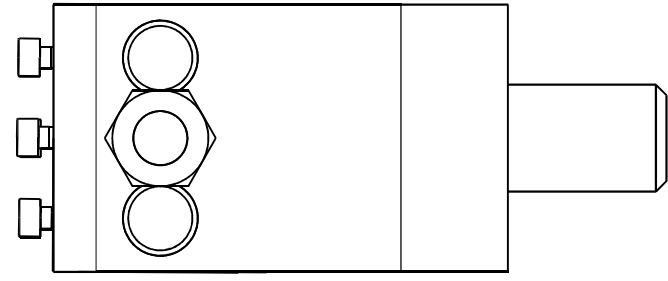

This drawing is our property.
It can't be reproduced
or communicated without
our written agreement.

DRAWN BY	DATE
I. Camino	11/06/2018
CHECKED BY	DATE
T. Scharlaken	11/06/2018
DESIGNED BY	DATE
I. Camino	11/06/2018

STRENGTH TESTING GRIP

DRAWING TITLE

Vise Grip

SIZE	DRAWING NUMBER	REV
A3	1	0
SCALE	1:1	WEIGHT (kg)
	3,77	
SHEET	1/1	

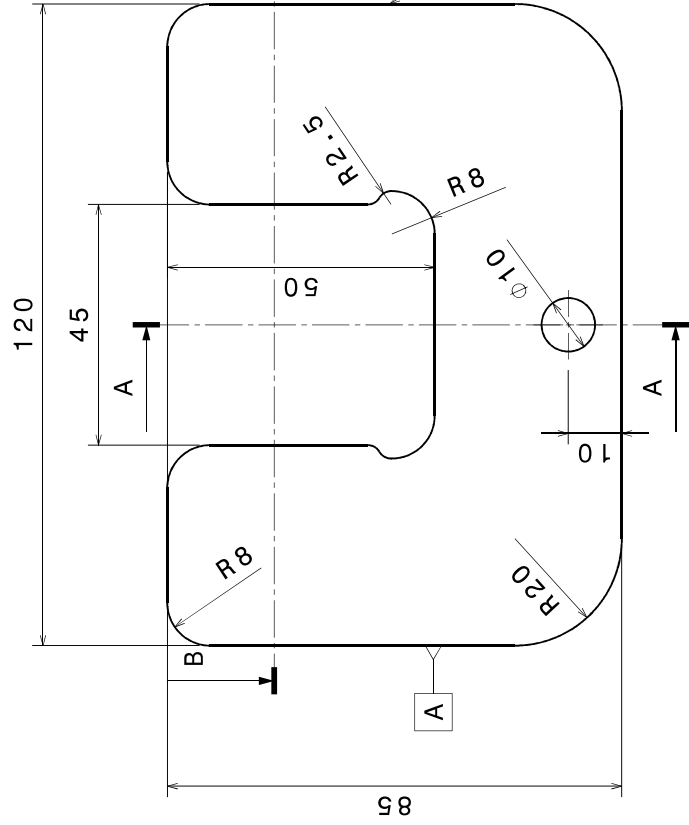

0.1 A

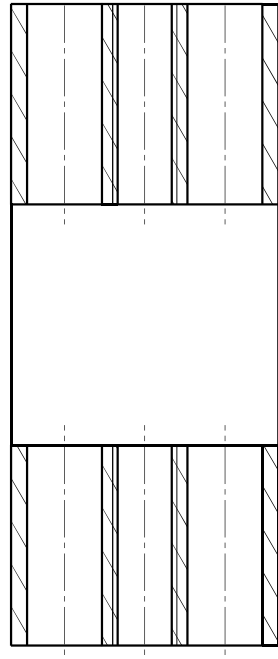
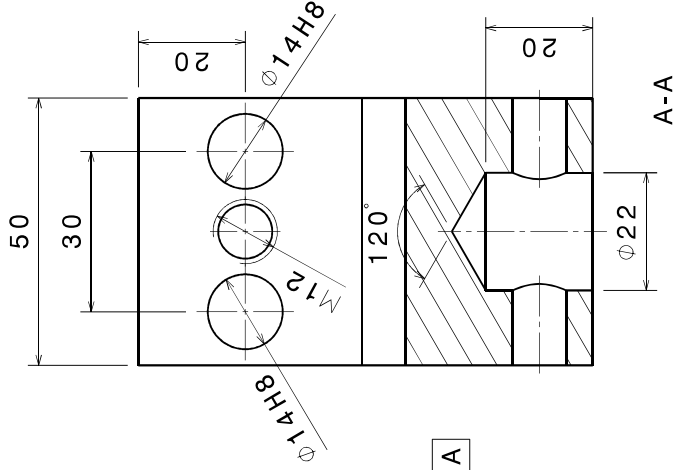

B-B

This drawing is our property. It can't be reproduced or communicated without our written agreement.

DRAWN BY	DATE
I. Camino	11/06/2018
CHECKED BY	DATE
T. Scharlaken	11/06/2018
DESIGNED BY	DATE
I. Camino	11/06/2018

STRENGTH TESTING GRIP

DRAWING TITLE

Grip Body

DRAWING NUMBER

2

REV

0

SCALE

1:1 WEIGHT (kg)

2.9

SHEET

1/1

H

G

F

E

D

C

B

A

4

3

2

1

4

3

2

1

4 3 2 1

A

B

C

D

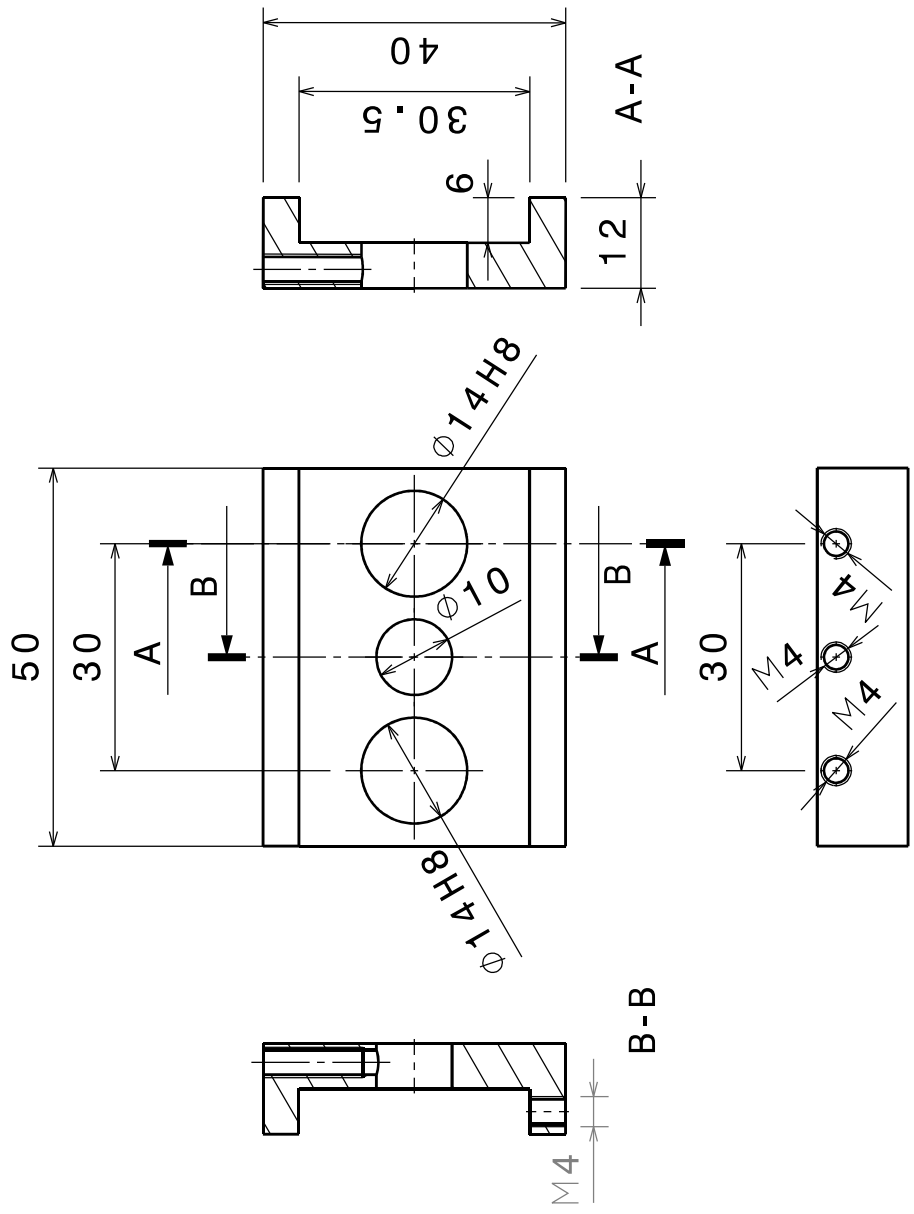

This drawing is our property. It can't be reproduced or communicated without our written agreement.

STRENGTH TESTING GRIP

DRAWING TITLE

Jaw

DRAWN BY	DATE
I. Camino	11/06/2018
CHECKED BY	DATE
T. Scharlaken	xxx
DESIGNED BY	DATE
I. Camino	xxx

SIZE	DRAWING NUMBER	REV
A4	3	0
SCALE	1:1	WEIGHT (kg)
		0.097
		SHEET
		1/1

4 3 2 1

A

D

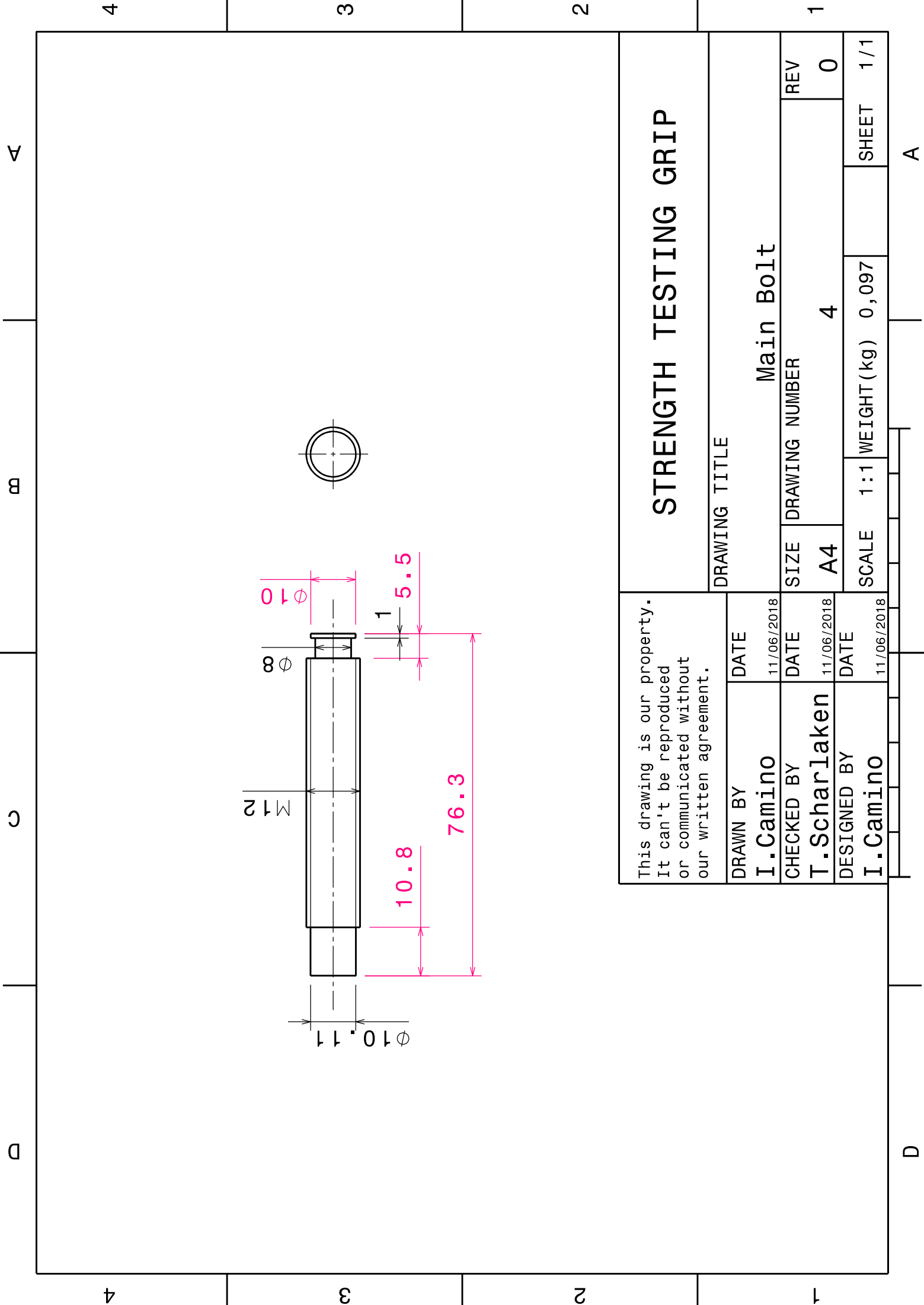

This drawing is our property.
 It can't be reproduced
 or communicated without
 our written agreement.

STRENGTH TESTING GRIP			
DRAWING TITLE			
DRAWN BY		Main Bolt	
I. Camino		REV	
CHECKED BY		DRAWING NUMBER	
T. Scharlaken		A4 4	
DESIGNED BY		SCALE	
I. Camino		1:1 WEIGHT (kg) 0,097	
DATE		SHEET	
11/06/2018		1/1	
DATE		REV	
11/06/2018		0	
DATE		11/06/2018	

A

B

C

D

4 3 2 1

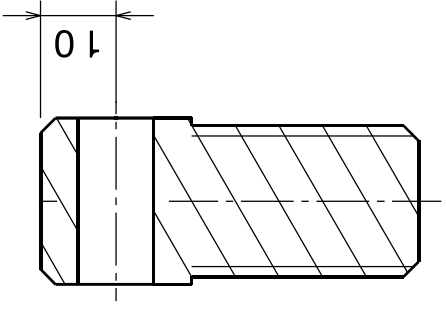
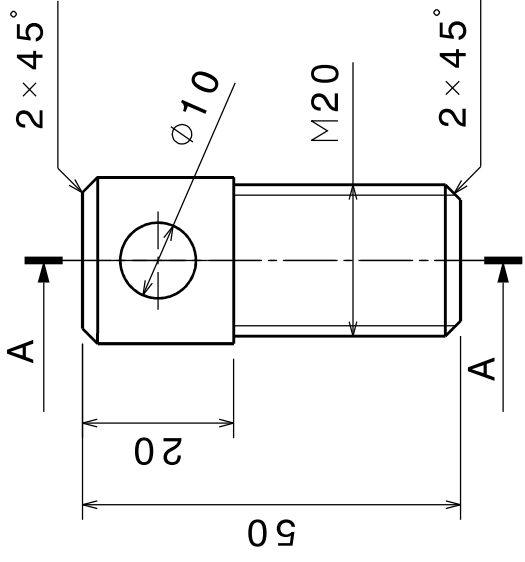

A-A

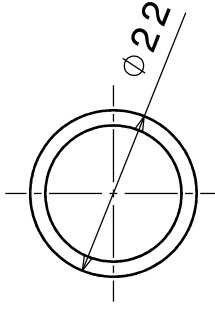

This drawing is our property.
It can't be reproduced
or communicated without
our written agreement.

STRENGTH TESTING GRIP

DRAWING TITLE

DRAWN BY	DATE
I. Camino	11/06/2018
CHECKED BY	DATE
T. Scharlaken	11/06/2018
DESIGNED BY	DATE
I. Camino	11/06/2018

Anchorage

SIZE	DRAWING NUMBER	REV
A4	5	0

SCALE	1:1	WEIGHT (kg)	0,085	SHEET	1/1
-------	-----	-------------	-------	-------	-----

10. ANNEX D

V-GRIP 1.0 Drawings

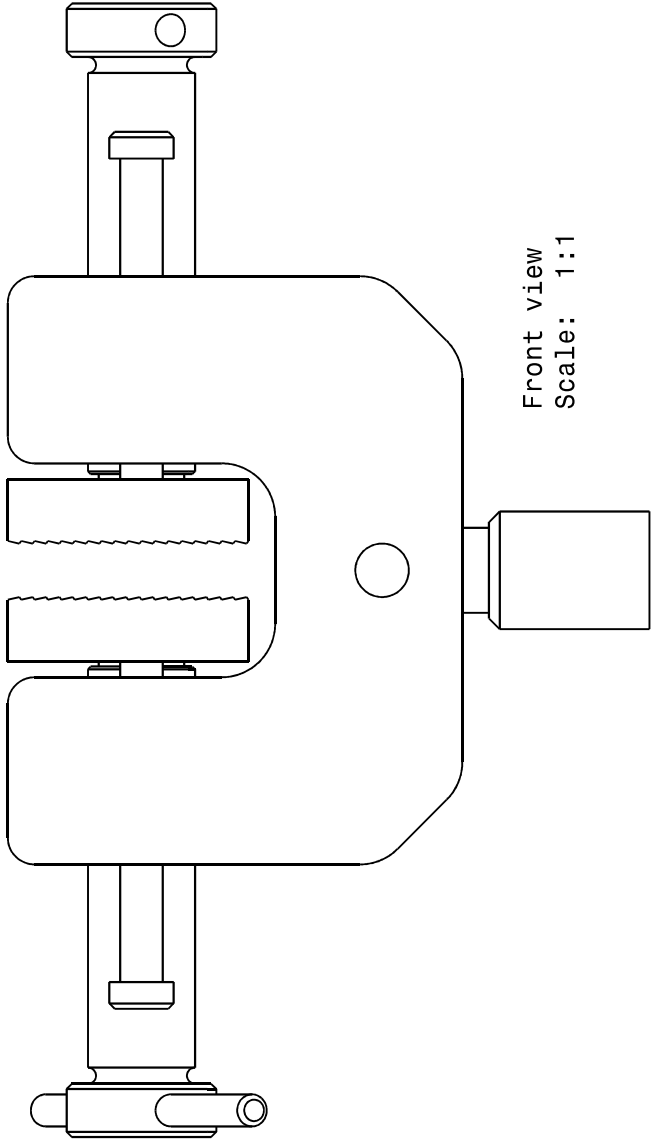

Front view
Scale: 1:1

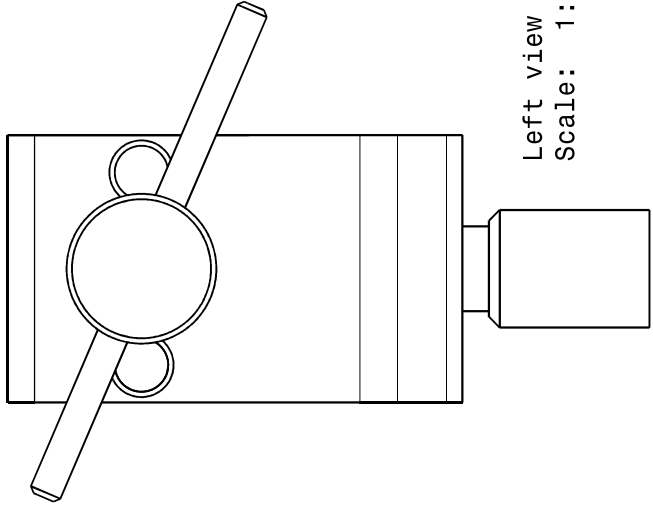

Left view
Scale: 1:1

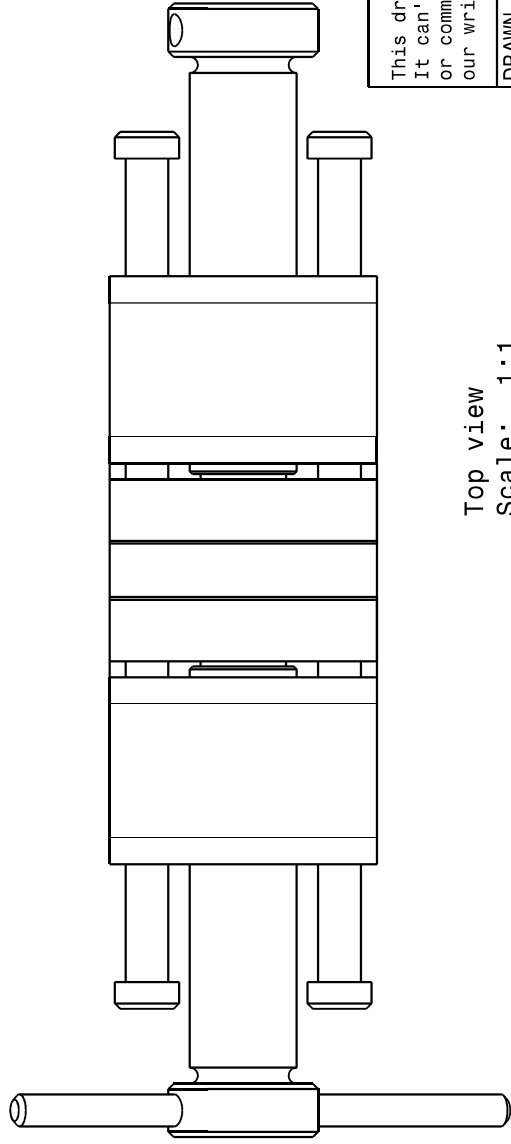

Top view
Scale: 1:1

Drawing number	Title
2	Body
3	Jaw
4	Central bolt
5	Guide bolt
5	Fastener
6	Support

This drawing is our property.
It can't be reproduced
or communicated without
our written agreement.

DRAWN BY Antonio Blanco	DATE 22/03/2018
CHECKED BY XXX	DATE xxx
DESIGNED BY Antonio Blanco	DATE xxx

DASSAULT SYSTEMES

DRAWING TITLE

DRAWING TITLE Product	
SIZE A3	DRAWING NUMBER 1
SCALE 1:1	WEIGHT (kg) 3,7
SHEET 1/1	REV X

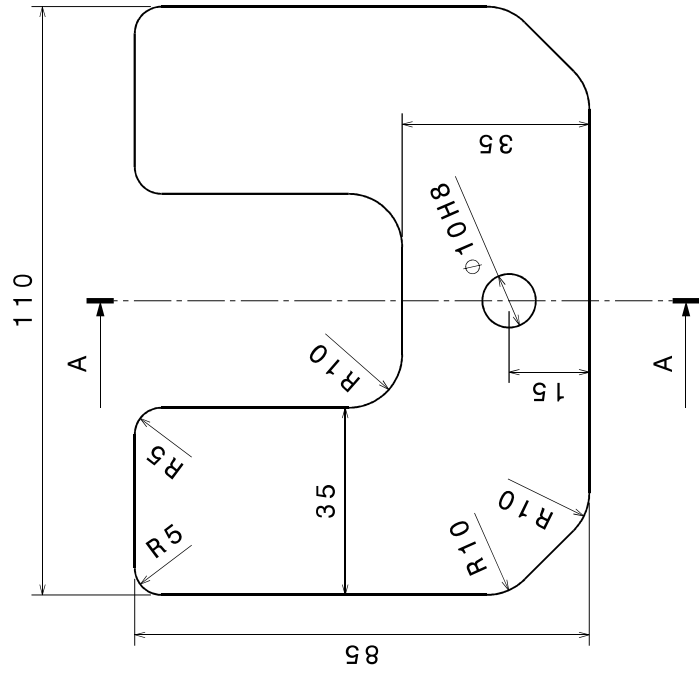

Front view
Scale: 1:1

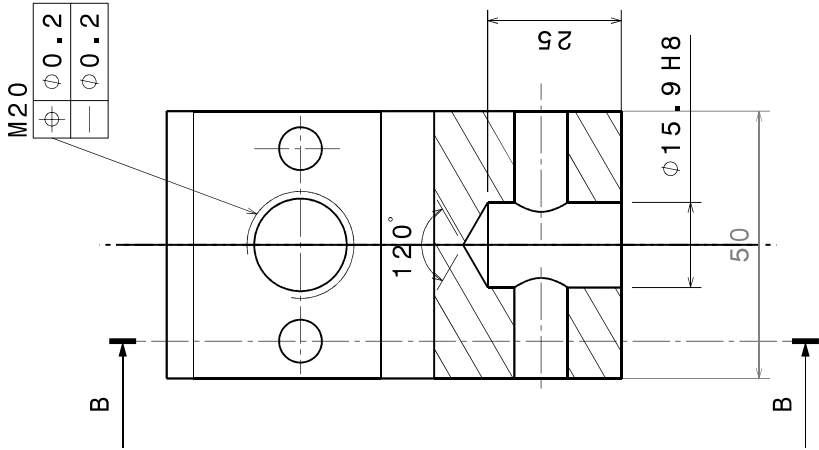

Section view A-A
Scale: 1:1

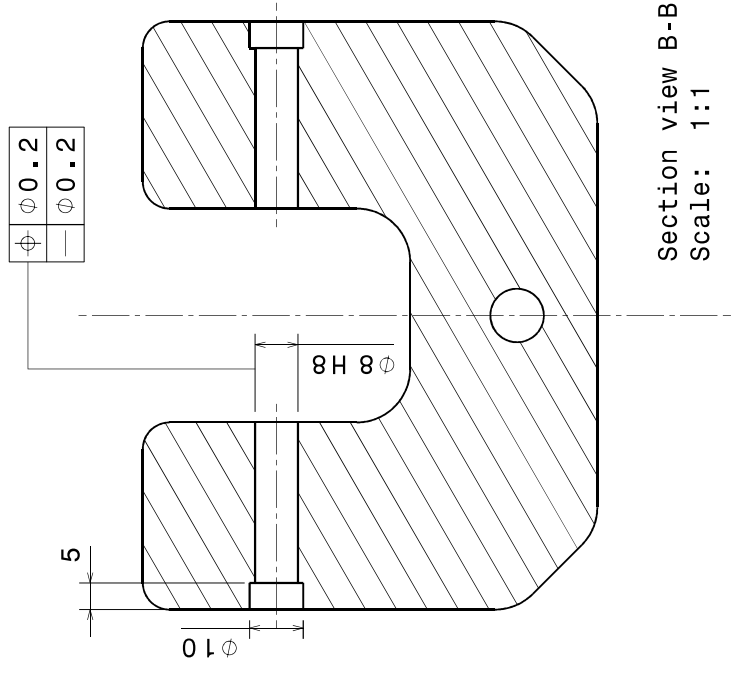

Section view B-B
Scale: 1:1

This drawing is our property.
It can't be reproduced
or communicated without
our written agreement.

DRAWN BY	DATE
Antonio Blanco	22/03/2018
CHECKED BY	DATE
XXX	xxx
DESIGNED BY	DATE
Antonio Blanco	xxx

DASSAULT SYSTEMES

DRAWING TITLE

Body

SIZE	DRAWING NUMBER	REV
A3	2	X

SCALE	1:1	WEIGHT (kg)	-	SHEET	1/1
-------	-----	-------------	---	-------	-----

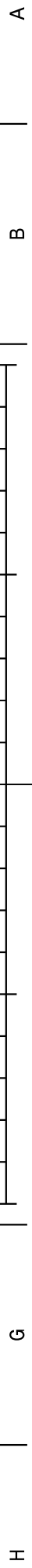

4 3 2 1

A

B

C

D

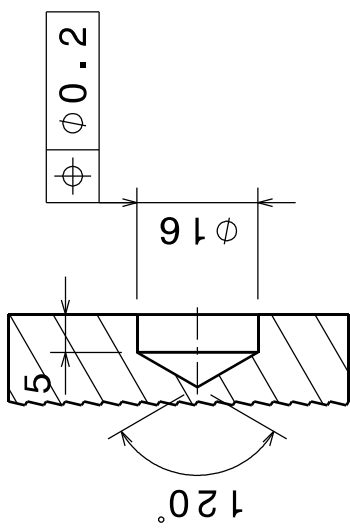
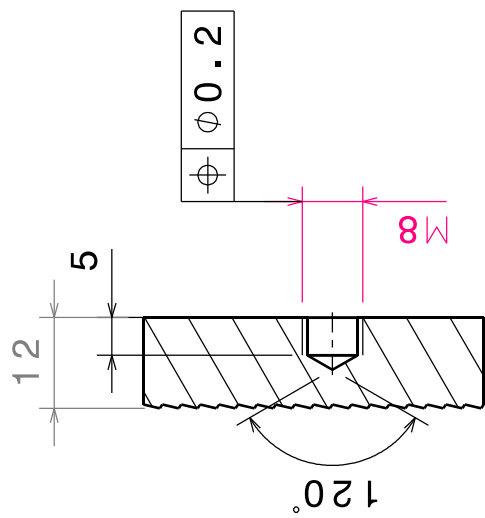
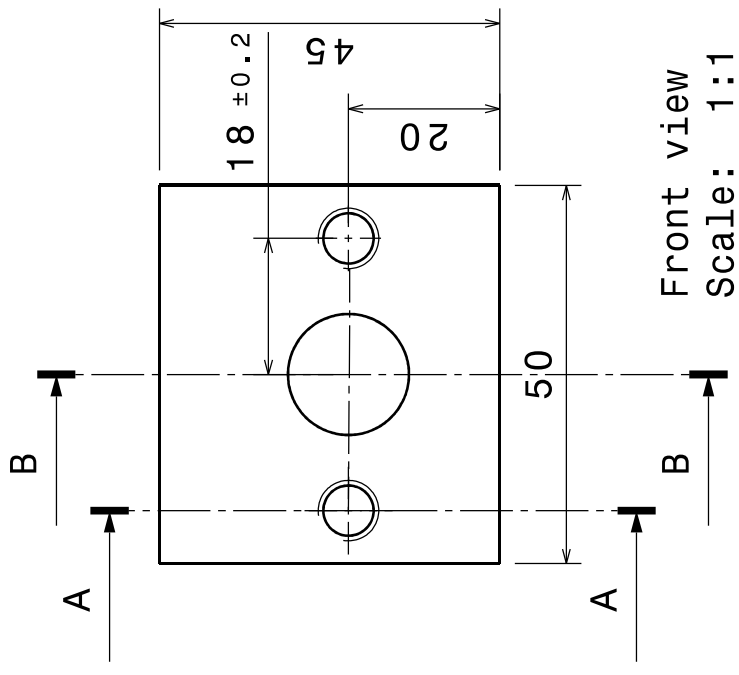

This drawing is our property.
It can't be reproduced
or communicated without
our written agreement.

DASSAULT SYSTEMES

DRAWING TITLE

DRAWN BY	DATE
Antonio Blanco	22/03/2018
CHECKED BY	DATE
XXX	xxx
DESIGNED BY	DATE
Antonio Blanco	xxx

Jaw

SIZE	DRAWING NUMBER	REV
A4	3	X

SCALE	1:1	WEIGHT (kg)	XXX	SHEET	1/1
-------	-----	-------------	-----	-------	-----

A

A

B

C

D

4

3

2

1

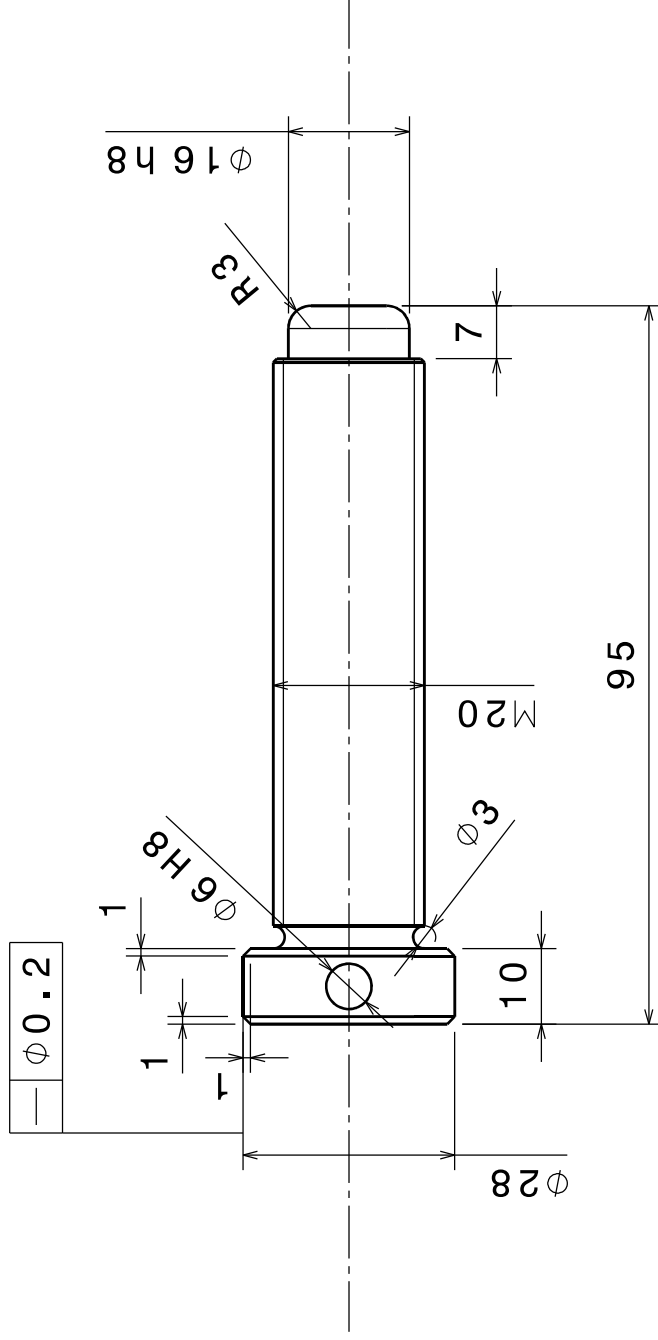

This drawing is our property.
It can't be reproduced
or communicated without
our written agreement.

DRAWN BY	DATE
Antonio Blanco	22/03/2018
CHECKED BY	DATE
XXX	xxx
DESIGNED BY	DATE
Antonio Blanco	xxx

DASSAULT SYSTEMES

DRAWING TITLE

Central bolt

SIZE	DRAWING NUMBER	REV
A4	4	X

SCALE	1:1	WEIGHT (kg)	-	SHEET	1/1
-------	-----	-------------	---	-------	-----

D

A

4

3

2

1

4 3 2 1

A

C

D

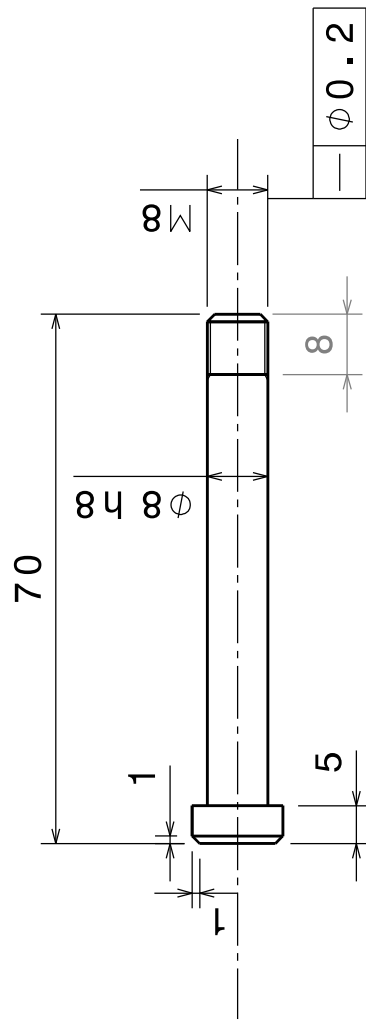

Guide bolt

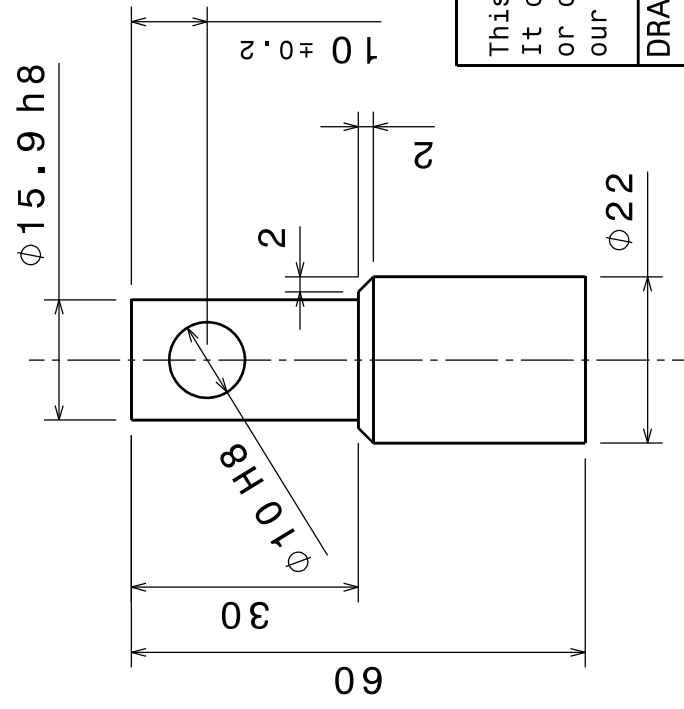

Support

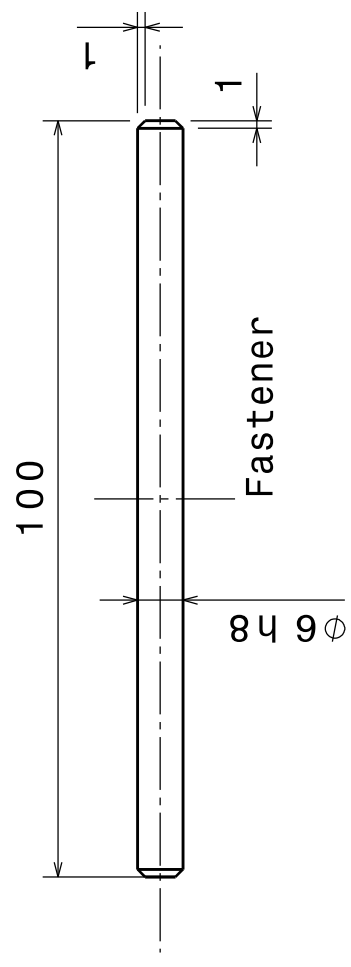

Fastener

This drawing is our property.
It can't be reproduced
or communicated without
our written agreement.

DASSAULT SYSTEMES

DRAWING TITLE

DRAWN BY	DATE
Antonio Blanco	22/03/2018
CHECKED BY	DATE
XXX	xxx
DESIGNED BY	DATE
Antonio Blanco	xxx

Guide bolt, fastener and support

SIZE	DRAWING NUMBER	REV
A4	5	X

SCALE	1:1	WEIGHT (kg)	-	SHEET	1/1
-------	-----	-------------	---	-------	-----

4 3 2 1

D

A

11. ANNEX E

V-GRIP 1.0 Drawings “As built”

4 3 2 1

A B C D E F G H

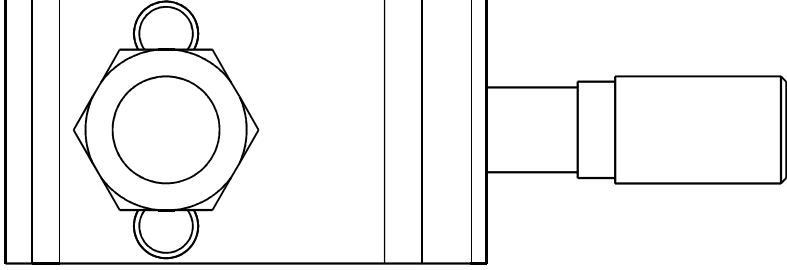

Drawing number	Title
2	Body
3	Jaw
4	Central bolt
5	Guide bolt
5	Support

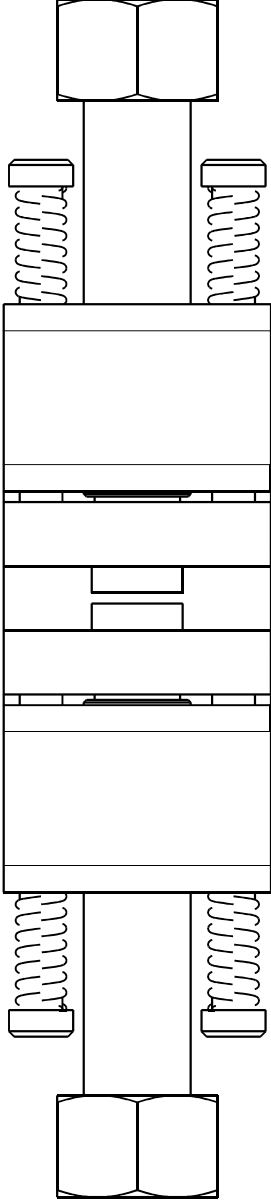
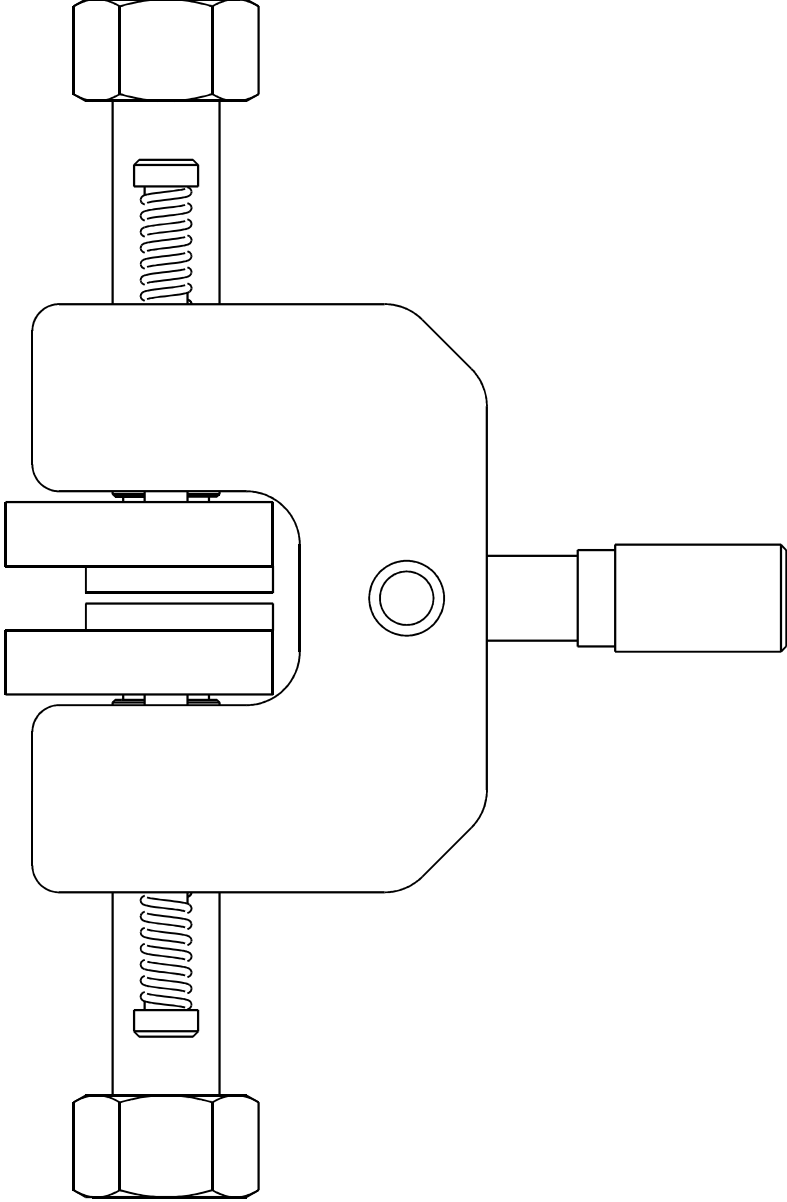

DRAWN BY		DATE		DRAWING TITLE		Product	
Antonio Blanco		22/03/2018		SIZE		REV	
CHECKED BY		DATE		DRAWING NUMBER		X	
XXX		XXX		A3		1	
DESIGNED BY		DATE		SCALE		SHEET	
Antonio Blanco		XXX		1:1 WEIGHT (kg)		1/1	

4 3 2 1

A B C D E F G H

4

3

2

1

4

3

2

1

H G F E D C B A

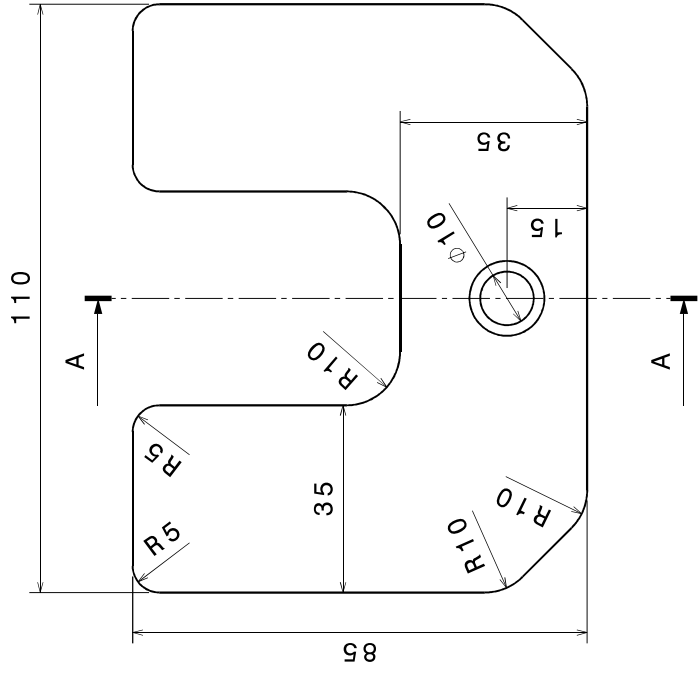

Section view A-A

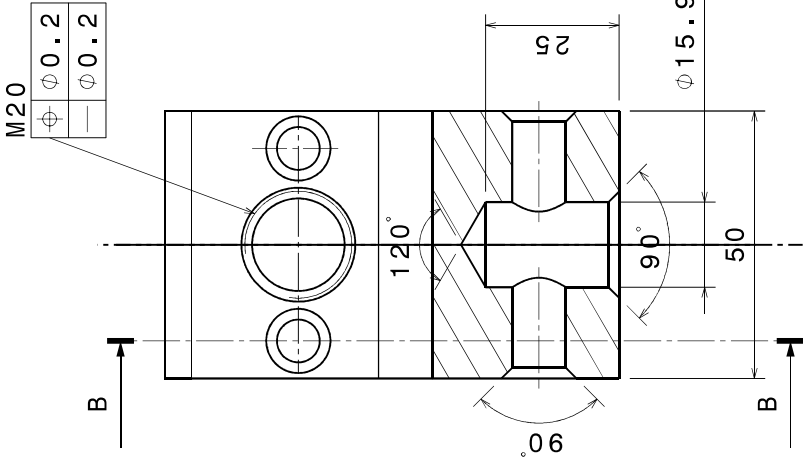

Section view B-B

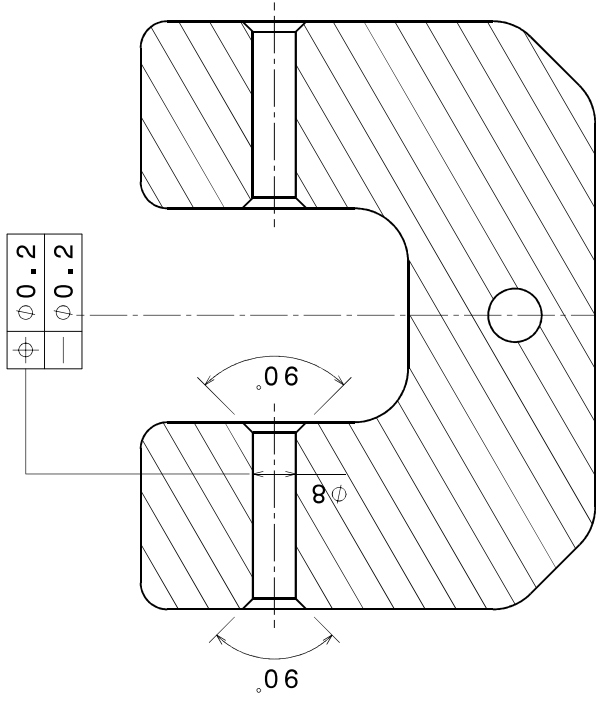

DRAWN BY Antonio Blanco	DATE 22/03/2018	DRAWING TITLE Body	
CHECKED BY XXX	DATE xxx	SIZE A3	REV X
DESIGNED BY Antonio Blanco	DATE xxx	DRAWING NUMBER 2	SHEET 1/1
SCALE 1:1		WEIGHT (kg) -	

H

G

F

E

D

C

B

A

A

B

C

D

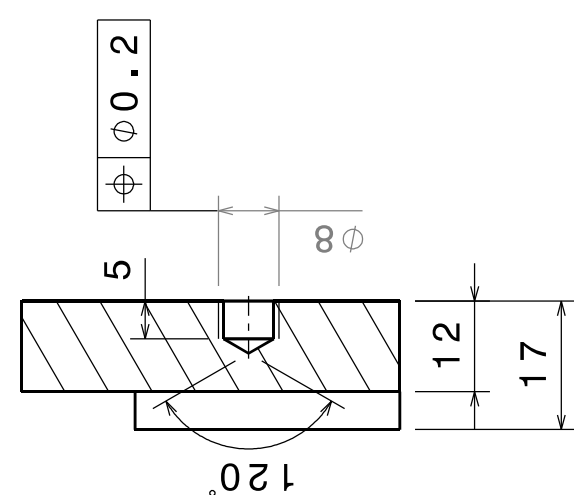
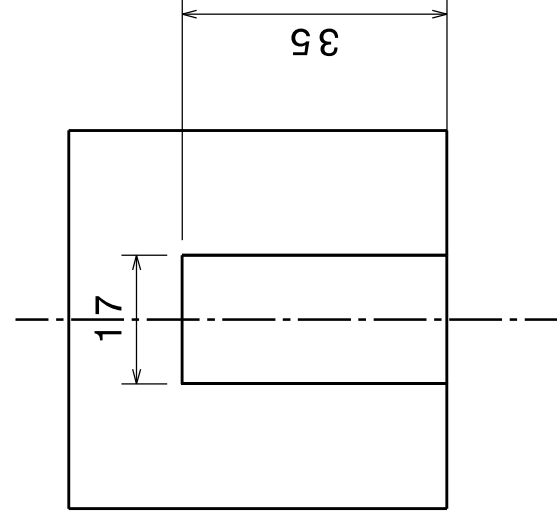

Section view A-A

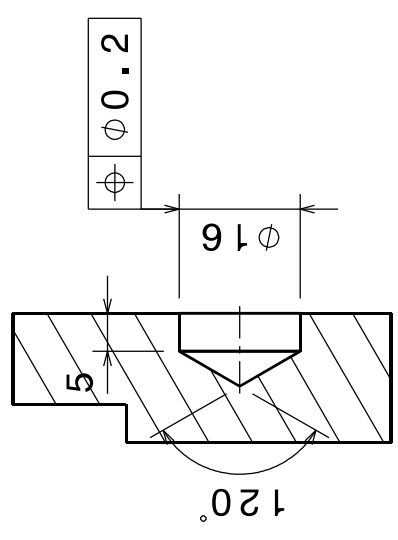
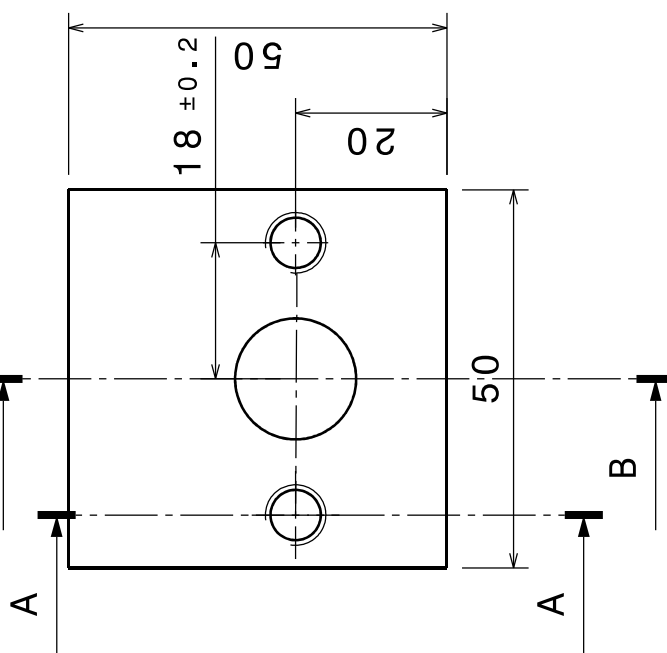

Section view B-B

DRAWN BY	DATE	DRAWING TITLE	
Antonio Blanco	22/03/2018	Jaw	
CHECKED BY	DATE	SIZE	DRAWING NUMBER
XXX	XXX	A4	3
DESIGNED BY	DATE	SCALE	WEIGHT (kg)
Antonio Blanco	XXX	1:1	XXX
		SHEET	1/1

A

D

4 3 2 1

a

c

D

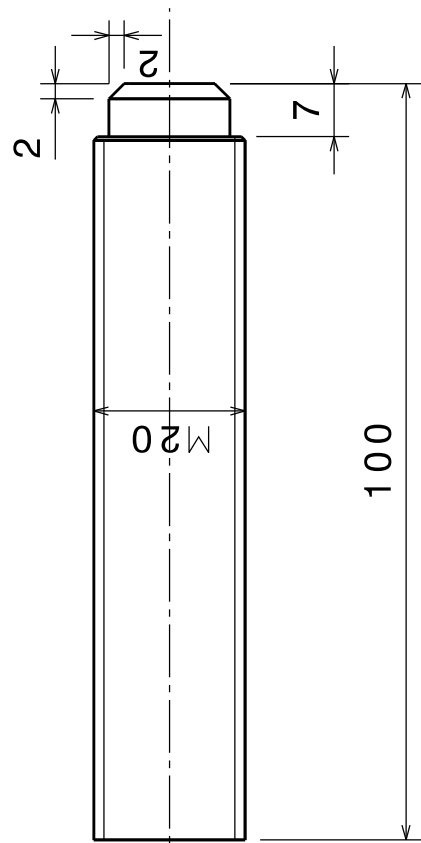

DRAWN BY	DATE	DRAWING TITLE	
Antonio Blanco	22/03/2018	Central bolt	
CHECKED BY	DATE	SIZE	DRAWING NUMBER
XXX	xxx	A4	4
DESIGNED BY	DATE	SCALE	WEIGHT (kg)
Antonio Blanco	xxx	1:1	-
		REV	SHEET
		X	1/1

A

D

4 3 2 1

4

A

C

D

4

4

3

3

2

2

1

1

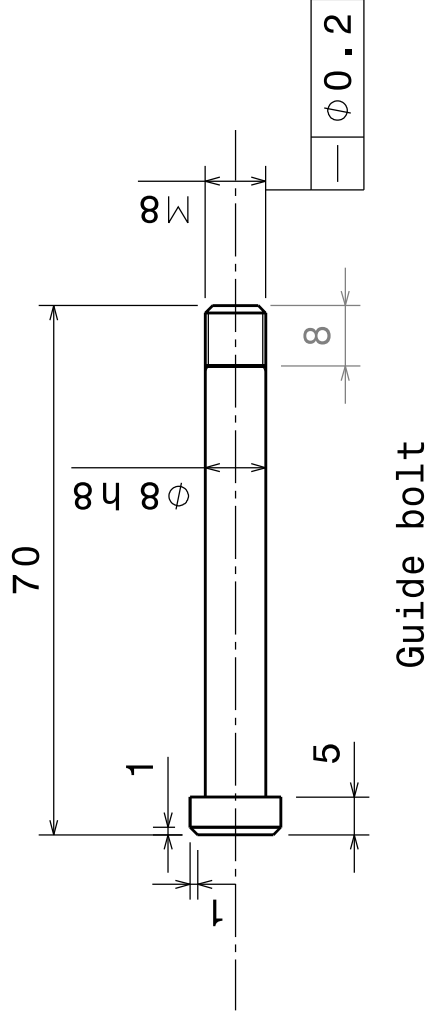
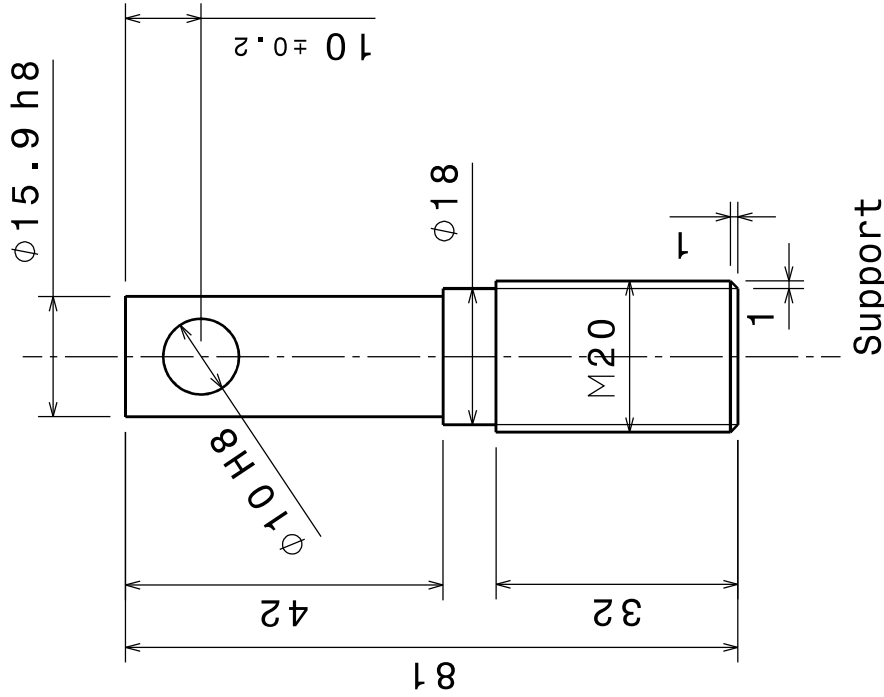

Guide bolt

DRAWN BY	DATE	DRAWING TITLE	
Antonio Blanco	22/03/2018	Guide bolt and support	
CHECKED BY	DATE	SIZE	DRAWING NUMBER
XXX	XXX	A4	5
DESIGNED BY	DATE	SCALE	WEIGHT (kg)
Antonio Blanco	XXX	1:1	-
		SHEET	1/1

A

D

12. ANNEX F

V-GRIP 2.0 Drawings

4

3

2

1

4

3

2

1

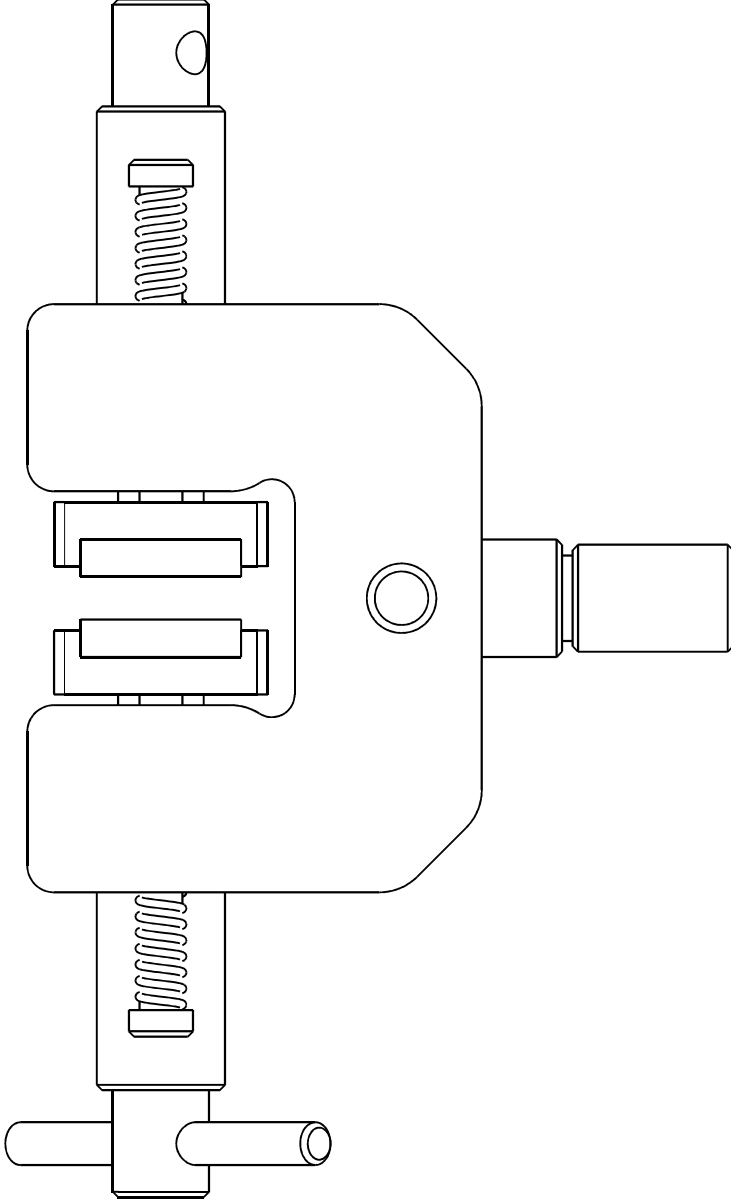
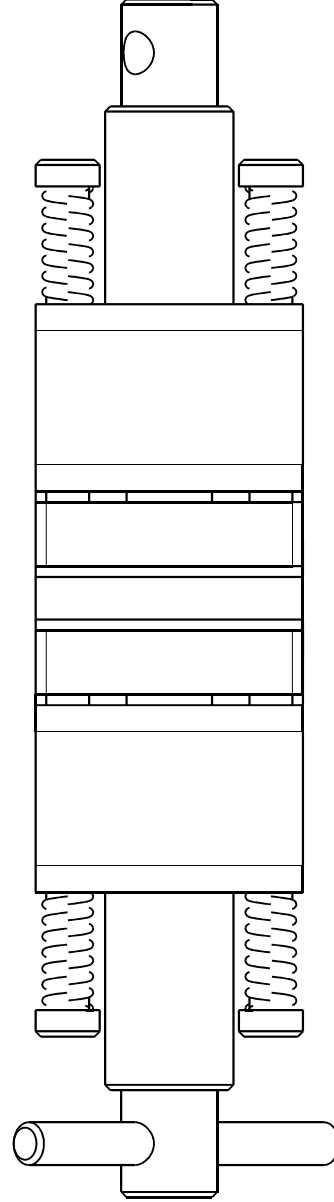
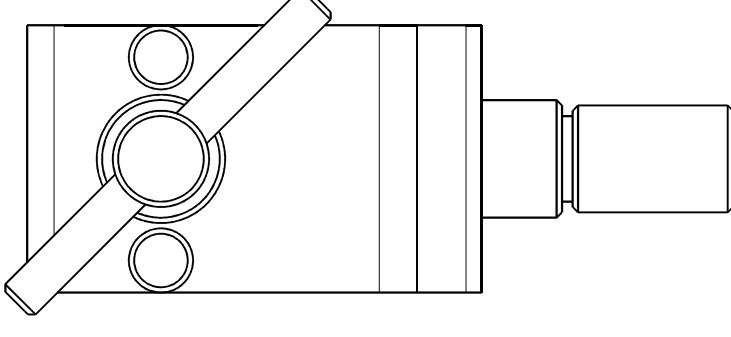

Drawing number	Title
2	Body
3	Jaw
3	File
4	Central bolt
4	Fastener
5	Guide bolt
5	Support

DRAWN BY Antonio Blanco		DATE 05/06/2018	DRAWING TITLE Product		1	
CHECKED BY XXX	DATE xxx	SIZE A3	DRAWING NUMBER 1		REV X	
DESIGNED BY Antonio Blanco	DATE xxx	SCALE 1:1	WEIGHT (kg) 3,77	SHEET 1/1		

H

G

F

E

D

C

B

A

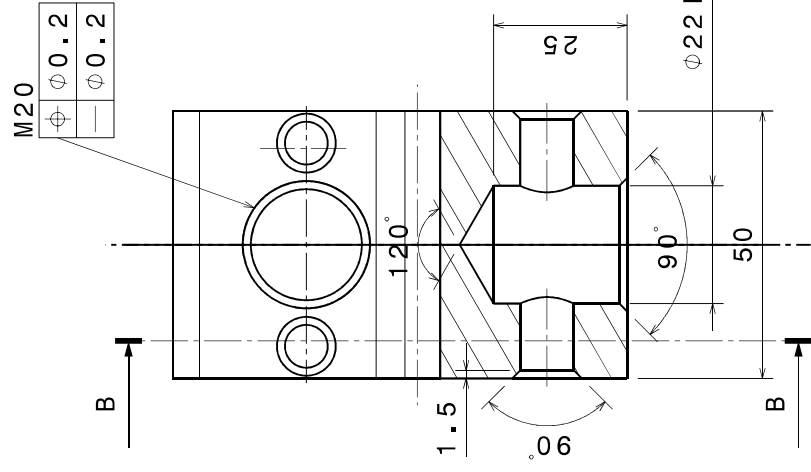
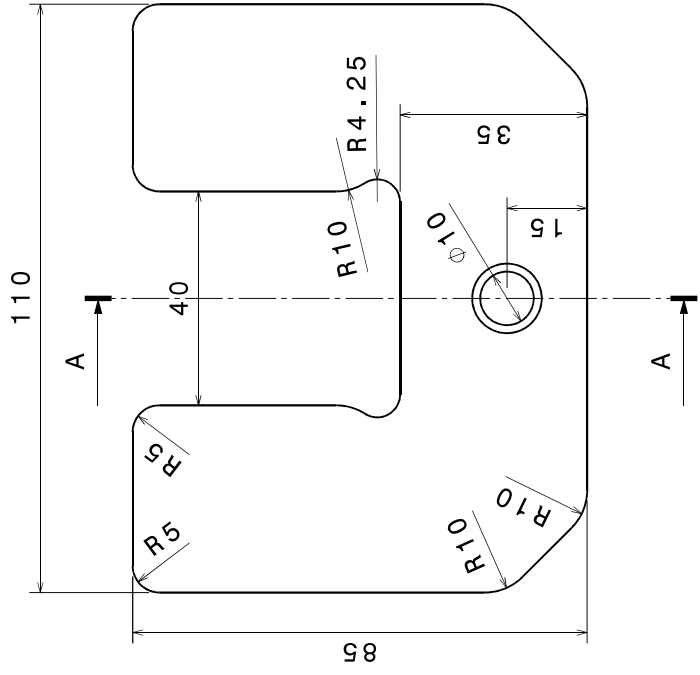

Section view A-A

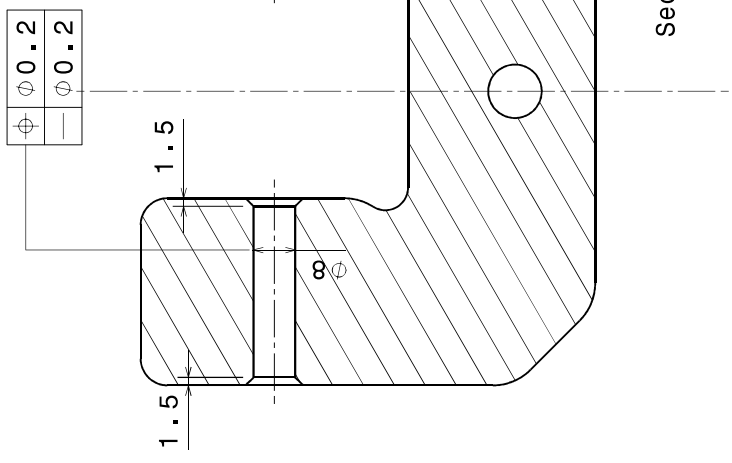

Section view B-B

\oplus	$\phi 0.2$
\ominus	$\phi 0.2$

M20	\oplus	$\phi 0.2$
	\ominus	$\phi 0.2$

DRAWN BY	DATE	DRAWING TITLE	REV
Antonio Blanco	05/06/2018	Body	
CHECKED BY	DATE	SIZE	DRAWING NUMBER
XXX	xxx	A3	2
DESIGNED BY	DATE	SCALE	1:1 WEIGHT (kg)
Antonio Blanco	xxx	-	-
			SHEET 1/1

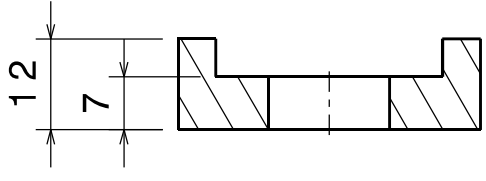
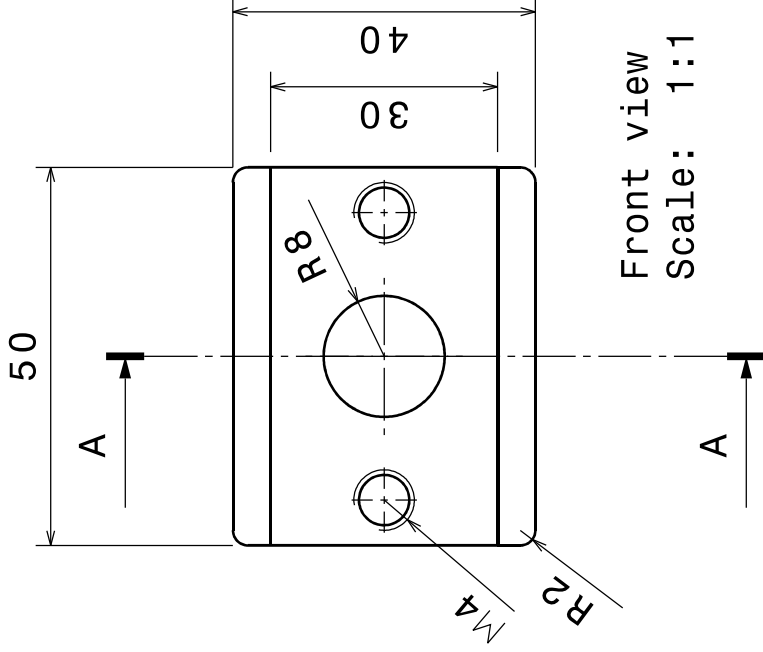

DRAWN BY	DATE	DRAWING TITLE	
Antonio Blanco	05/06/2018	Jaw	
CHECKED BY	DATE	SIZE	DRAWING NUMBER
XXX	XXX	A4	3
DESIGNED BY	DATE	SCALE	WEIGHT (kg)
Antonio Blanco	XXX	1:1	XXX
		SHEET	REV
		1/1	X

4 3 2 1

∞

C

D

4 3 2 1

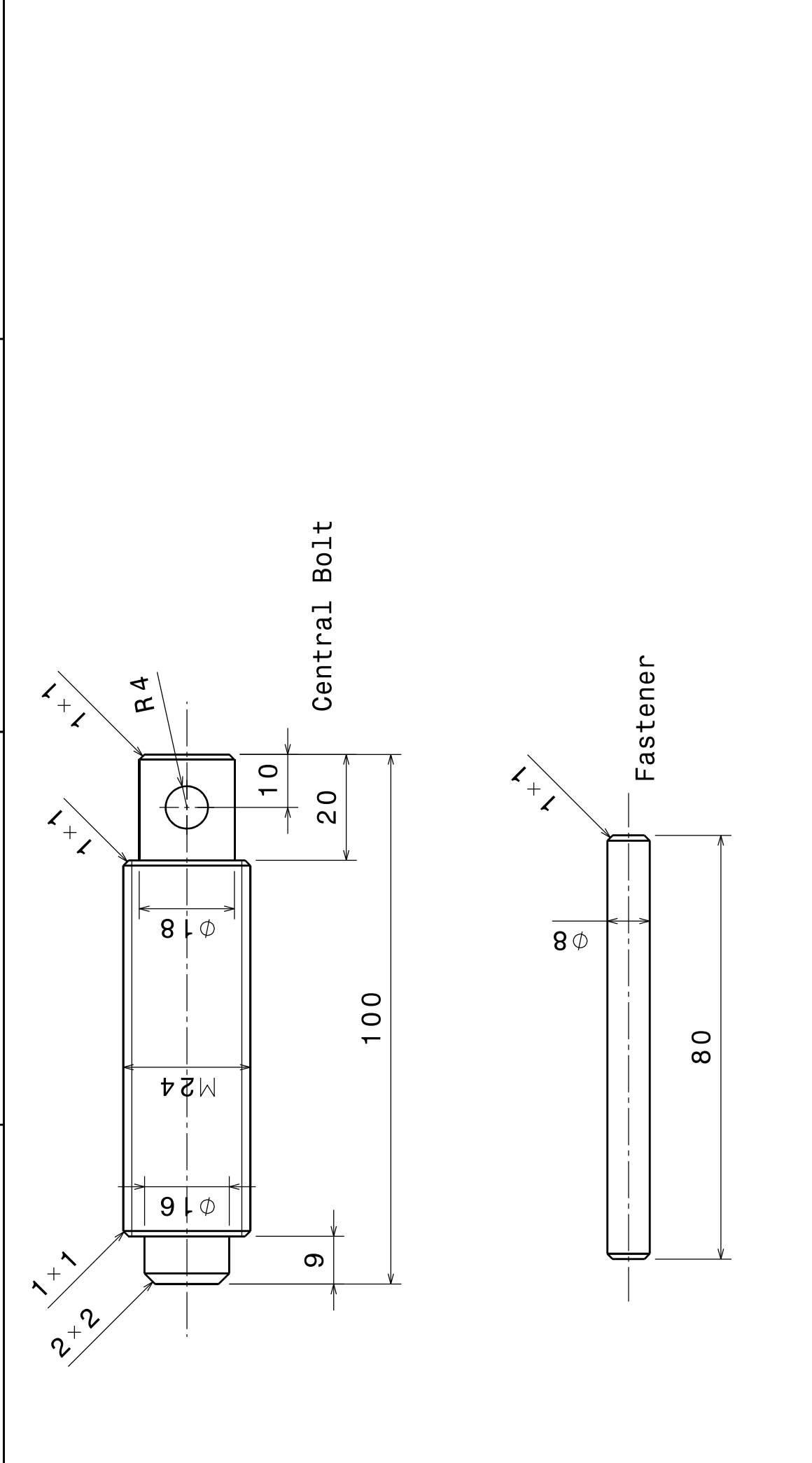

Central Bolt

Fastener

DRAWN BY	DATE	DRAWING TITLE		
Antonio Blanco	05/06/2018	Central bolt and Fastener		
CHECKED BY	DATE	SIZE	DRAWING NUMBER	REV
XXX	XXX	A4	4	X
DESIGNED BY	DATE	SCALE	1:1	WEIGHT (kg)
Antonio Blanco	XXX	-	-	1/1

A

D

4 3 2 1

α

γ

δ

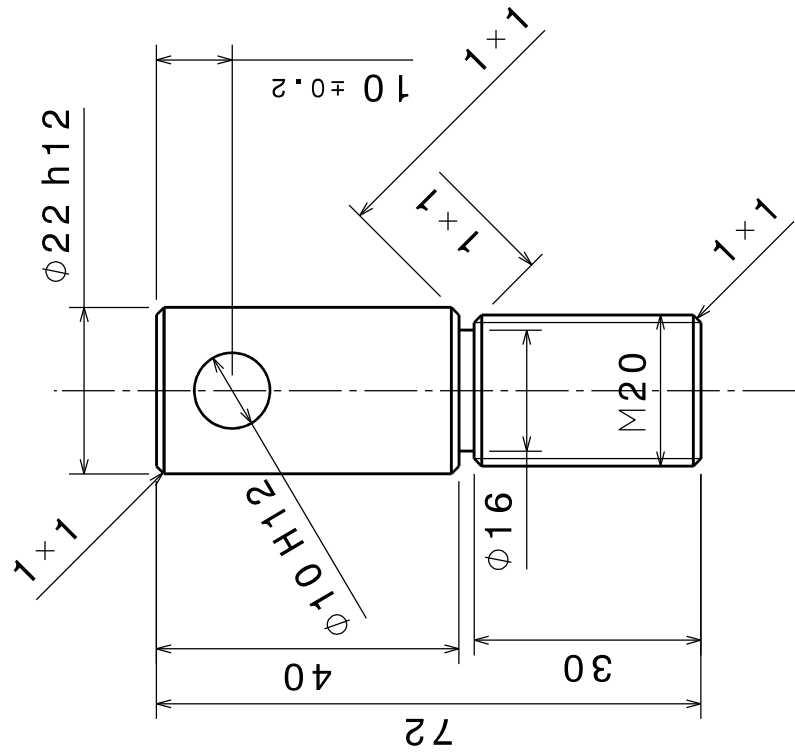

Support

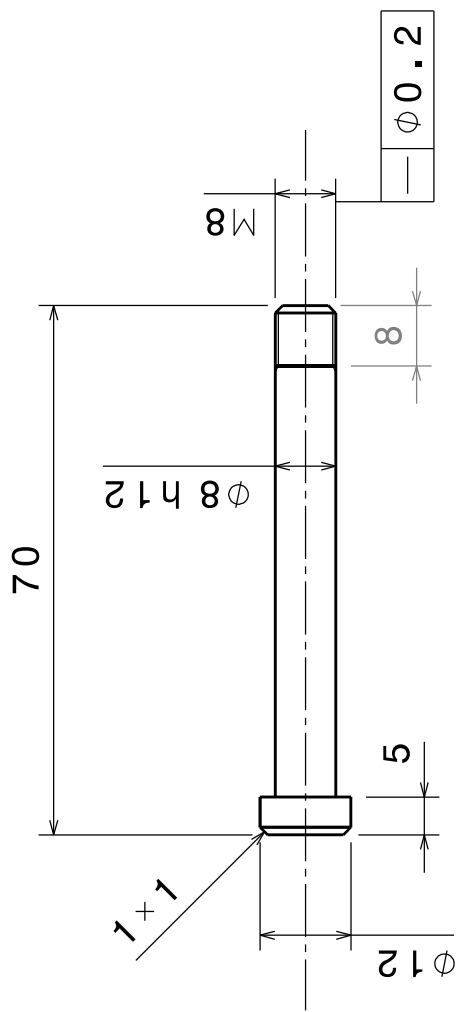

Guide bolt

DRAWN BY	DATE	DRAWING TITLE	
Antonio Blanco	05/06/2018	Guide bolt and support	
CHECKED BY	DATE	SIZE	DRAWING NUMBER
XXX	XXX	A4	5
DESIGNED BY	DATE	SCALE	WEIGHT (kg)
Antonio Blanco	XXX	1:1	-
		SHEET	1/1

4 3 2 1

A

D