



**Universidad de Valladolid**



**ESCUELA DE INGENIERÍAS  
INDUSTRIALES**

**UNIVERSIDAD DE VALLADOLID**

**ESCUELA DE INGENIERIAS INDUSTRIALES**

**Grado en Ingeniería en Diseño Industrial y Desarrollo de  
Producto**

## **FLOW: Renewable Energy**

**Autor:**

**Martínez Casais, Henar**

**Responsable de Intercambio en la UVa**

**Fernández Villalobos, Nieves**

**Universidad de Amberes**

**Valladolid, junio de 2019.**

## TFG REALIZADO EN PROGRAMA DE INTERCAMBIO

---

TÍTULO: **FLOW: Renewable Energy**

ALUMNO: **Henar Martínez Casais**

FECHA: **18 de junio de 2019**

CENTRO: **Facultad de Ciencias del Diseño**

TUTOR: **Regan Watts**

## **Resumen del TFG:**

El proyecto *FLOW: Renewable Energy* consiste en la elaboración de tres prototipos experimentales y funcionales relativos a la física e integrados en equipos electrónicos.

Este conjunto de experimentos está basado en la educación STEM y nace con el propósito de ser integrado en los laboratorios de física. De este modo, se enseña a los alumnos el funcionamiento y uso de fuentes alternativas de energía, en particular, energía solar, hidráulica y eólica, así como los principios de física asociados.

Gracias a este proyecto, se consigue que los estudiantes se sientan atraídos por la ciencia y consigan implementar sus conocimientos teóricos en un contexto de la vida real.

El kit de prototipos FLOW ha sido desarrollado durante el *European Project Semester* en 2019 y fabricado en la Universidad de Amberes. Asimismo, estos experimentos están dirigidos para alumnos de 4º ESO – 2º Bachillerato en Flandes, Bélgica.

## **Cinco palabras clave que describen el TFG:**

ENERGÍAS RENOVABLES - STEM – CIENCIA - EDUCACIÓN – EXPERIMENTOS

## **VERSIÓN EN INGLÉS**

### **Abstract**

The *FLOW: Renewable Energy* project consists of the development of three experimental and functional prototypes related to physics and integrated into electronic equipment.

This set of experiments is based on STEM education and was born with the purpose of being integrated in physics laboratories. In this way, students are taught about alternative sources of energy, specifically, solar, hydraulic and wind energy, as well as associated physics principles.

Thanks to this project, pupils are excited about science and are able to implement their theoretical knowledge into a real-life context.

The FLOW prototype kit has been developed during the European Project Semester in 2019 and manufactured at the University of Antwerp. Likewise, these experiments will be suitable for students from the 4th to 6th grade ASO in Flanders, Belgium.

## **Keywords**

RENEWABLE ENERGY – STEM – SCIENCE – EDUCATION - EXPERIMENTS



**Team members:** Duy Nguyen, Emilio de Jonghe, Gabriela Pereira,  
Henar Martínez, Paula Navarro

**Supervisor:** Regan Watts

**European Project Semester 2019**

# Acknowledgement



This project would not have been possible without the help and supervision of the different members of the European Project Semester, as well as the University of Antwerp.

One of these members is Sarah Rohaert, whose organization and coordination during the project has been impeccable, and has allowed us to participate in this unique and extraordinary experience.

We would like to thank Regan Watts, our supervisor and physics expert, for providing us with the opportunity to become the fifth Energy Wizards team, as well as the support, enthusiasm, and knowledge that he has transmitted to us at all times in order to accomplish this project.

A special thanks to Tinne Van Kogelenberg, a physics teacher at Sint Willebrord-Heilige Familie, who guided and advised us in the education field. In addition, she offered us time and supervision to implement our usability test in the workshop.

For all the assistance in writing the exercises and to integrate them properly into the curriculum, we wish to make a special mention of Dennis Dewit, physics education expert and Flow team collaborator.

The realization of prototypes comes from the hand of Jochen Vleugels, electronic and 3D printing expert, who taught us and assisted throughout the process of design and prototyping of the project, particularly his support with the prototypes of the windmill and the hydro turbine has been extraordinary, for which we are greatly grateful.

We thank Danny Stoop and Carlo Van Hove for the technical assistance they have offered us during the prototyping phase.

Last but not least, an infinite thanks to our EPS colleagues and family members. Without their support, encouragement, and wisdom, this would never have been possible.

# Abstract

Currently, innovation and science build the world around us, becoming a key part of education and progress towards a promising future. For this reason, we propose the immersion of ASO students from the 4th to 6th grade in an interactive socio-scientific environment, in which open-structure problems with multiple solutions are introduced with the purpose of assessing the students' ability to find resolution methods according to the experiments as well as draw conclusions from them.

First, a study was conducted identifying the main problems that cause students' lack of enthusiasm for science, among which the lack of accessibility for experiments that provide the perfect balance of fun and scientific learning. As a result, a field investigation was conducted by interviews with teachers of physics and visits to communication centres of science and engineering, which led to the teaching of scientific and moral reasoning in real-world situations, taking into account the ethical-social problems related to science and, in particular, to renewable energy.

With the results obtained and with the purpose of meeting the aforementioned objectives, the Flow team, which comprises industrial design engineers, product developers, and an environmental engineer, has developed a workshop that provides students and teachers with a series of experiments based on renewable energy, through which science and fun come together to transmit the values that the Flemish government wishes to fulfil.

The purpose of this workshop, based on STEM (Science, Technology, Engineering and Mathematics) education, is to experiment using alternative sources of energy, specifically solar, wind and hydraulic energy, as well as performing measurements and drawing graphs, as a result of which students will learn to investigate and solve problems by themselves.

In conclusion, our aim is to bring innovation and scientific knowledge to the classroom, providing alternative methods of teaching and learning, at the same time that we adopt a collective social conscience through which students coherently reflect the training and the implications of their own reasoning.



## State of art

The number of experiments that are conducted in the physical class of ASO schools differs depending on the grade in which the student is. Thus, for the pupils of the 3rd and 4th grade, a minimum of 7 experiments per course are performed, while in the 5th and 6th grade they conduct experiments at least 6 times. Naturally, teachers do not always have the necessary tools to make science fun and comprehensible in the classroom.

In addition, we have taken into consideration of the previous editions of Energy Wizards projects, EON and H<sub>2</sub>OME, as inspiration and guide: EON, a windmill with an innovative design that generates energy as well as H<sub>2</sub>OME, a solar heater that shows clearly the physics behind the experiment.

## Keywords

Renewable energy – STEM – Science  
Teachers – Students – Workshop

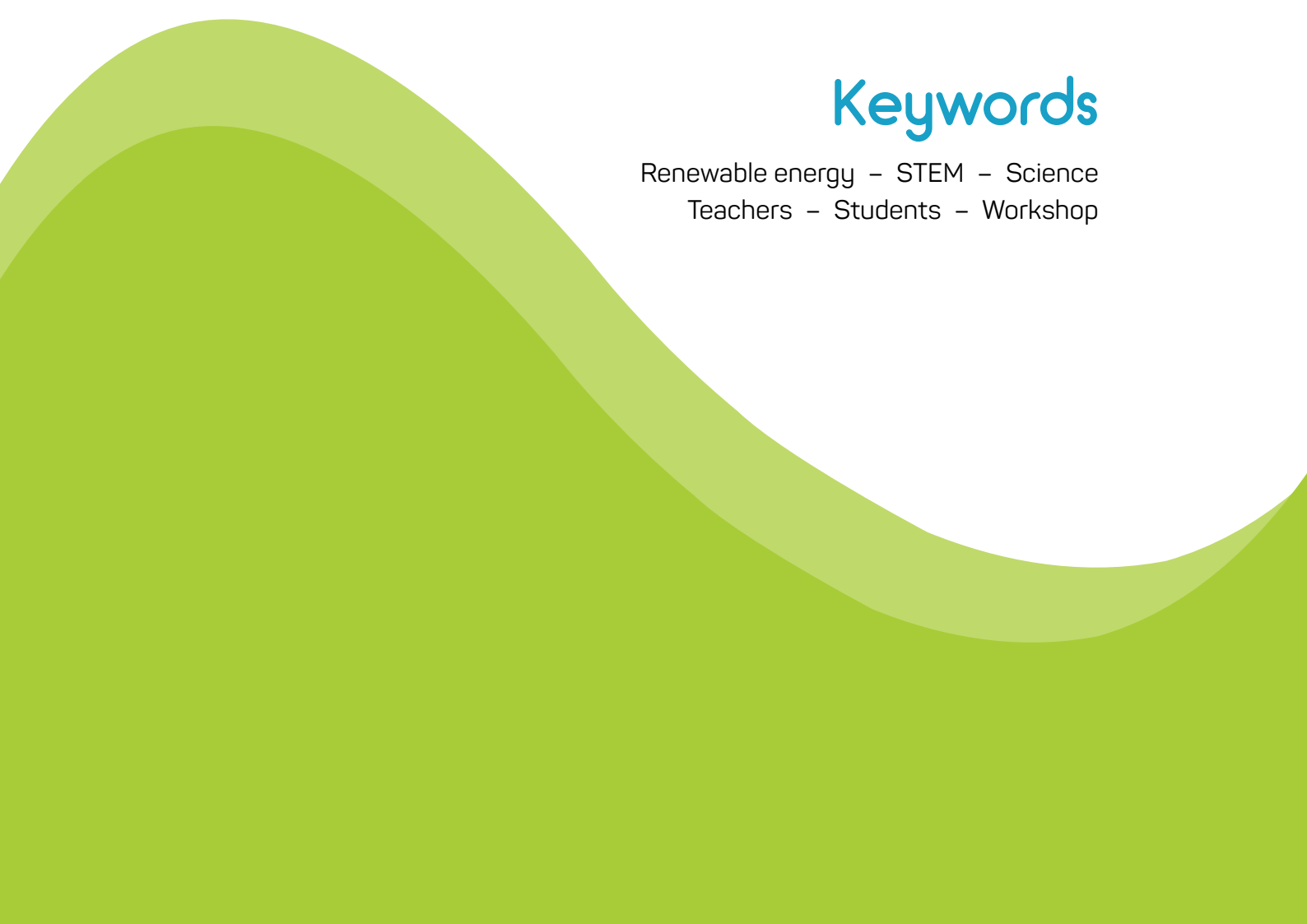



# Contents

## 1 Introduction ..... 9

## 2 Project Definition .... 15

- .1 Problem..... 16
- .2 Aim..... 16
- .3 Environment ..... 16
- .4 Interested Parties ..... 16
- .5 Resources..... 16

## 3 Research ..... 19

- .1 Market research ..... 20
- .2 Topic research..... 20
- .3 Curriculum research..... 20
- .4 Previous projects ..... 21
- .5 Teachers..... 23

<b>4</b>	<b>Our Project .....</b>	<b>25</b>
	.1 Design brief .....	26
	.2 Marketing .....	28
	.3 Concept generation.....	30
	.4 Windmill.....	31
	.5 Solar thermal.....	38
	.6 Water turbine.....	44
	.7 House .....	51
	.8 Testing.....	54

<b>5</b>	<b>Experiments' exercises.....</b>	<b>59</b>
----------	------------------------------------	-----------

<b>6</b>	<b>Conclusions and recommendations....</b>	<b>66</b>
----------	------------------------------------------------	-----------

	<b>Appendices.....</b>	<b>73</b>
--	------------------------	-----------

# Acronyms

---





A	Ampere
ABS	Acrylonitrile Butadiene Styrene
ASO	General Secondary Education Schools
BMC	Business Model Canvas
CAD	Computer aided design
CNC	Computer numerical control
DC	Direct Current
EPS	European Project Semester
STEM	Science Technology Engineering and Mathematics
LCD	Liquid Crystal Display
LED	Light Emitting Diode
MDF	Medium-density fibreboard
MVP	Minimum Viable Product
PLA	Polylactic Acid
PVC	Polyvinylchloride
QR code	Quick Response Code
RFID	Radio-Frequency Identification
STL	The Standard Template Library
SWH	Solar Water Heater
UX	User Experience
V	Voltage







# 1. Introduction



Currently, in the context of global warming, rapid development in science such as energy production, ecology, and sustainability has caused an increasing demand for jobs of engineers and scientists. However, we are lacking a sufficient amount of human resources to provide a boost of improvement and innovation in these fields. Therefore, to attract more teenagers and students to this area, the world is integrating STEM subjects into the education system. In particular, the Flemish government has released a framework to promote STEM in schools and the purpose of the Energy Wizards project is to assist and improve the use of STEM subjects. The project is a part of the European Project Semester (EPS) and it is hosted by the University of Antwerp in Belgium.

In this report, we would like to present our work process and the products. The report consists of six chapters. Chapter one is this introduction. Chapter two discusses the project's definition and goals. Chapter three includes all the research and the design brief is described in chapter four. Chapter five presents our experiment kits and the result is concluded in chapter six.



# The team

---



**Duy**

**VIETNAM**

**Environmental Engineer**

nguyenduy010798@gmail.com



**Emilio**

**BELGIUM**

**Product Developer**

emiliodejonghe@gmail.com





**Gabriela**

**BRAZIL**

**Product Developer**

[gabipereira17@hotmail.com](mailto:gabipereira17@hotmail.com)



**Henar**

**SPAIN**

**Product Developer**

[hmcasais@gmail.com](mailto:hmcasais@gmail.com)



**Paula**

**SPAIN**

**Product Developer**

paulanasa@gmail.com



GESS<sup>®</sup>  
U.S.A.  
MADE IN

flow

flow

ADAPT

# 2 Project 2. Definition

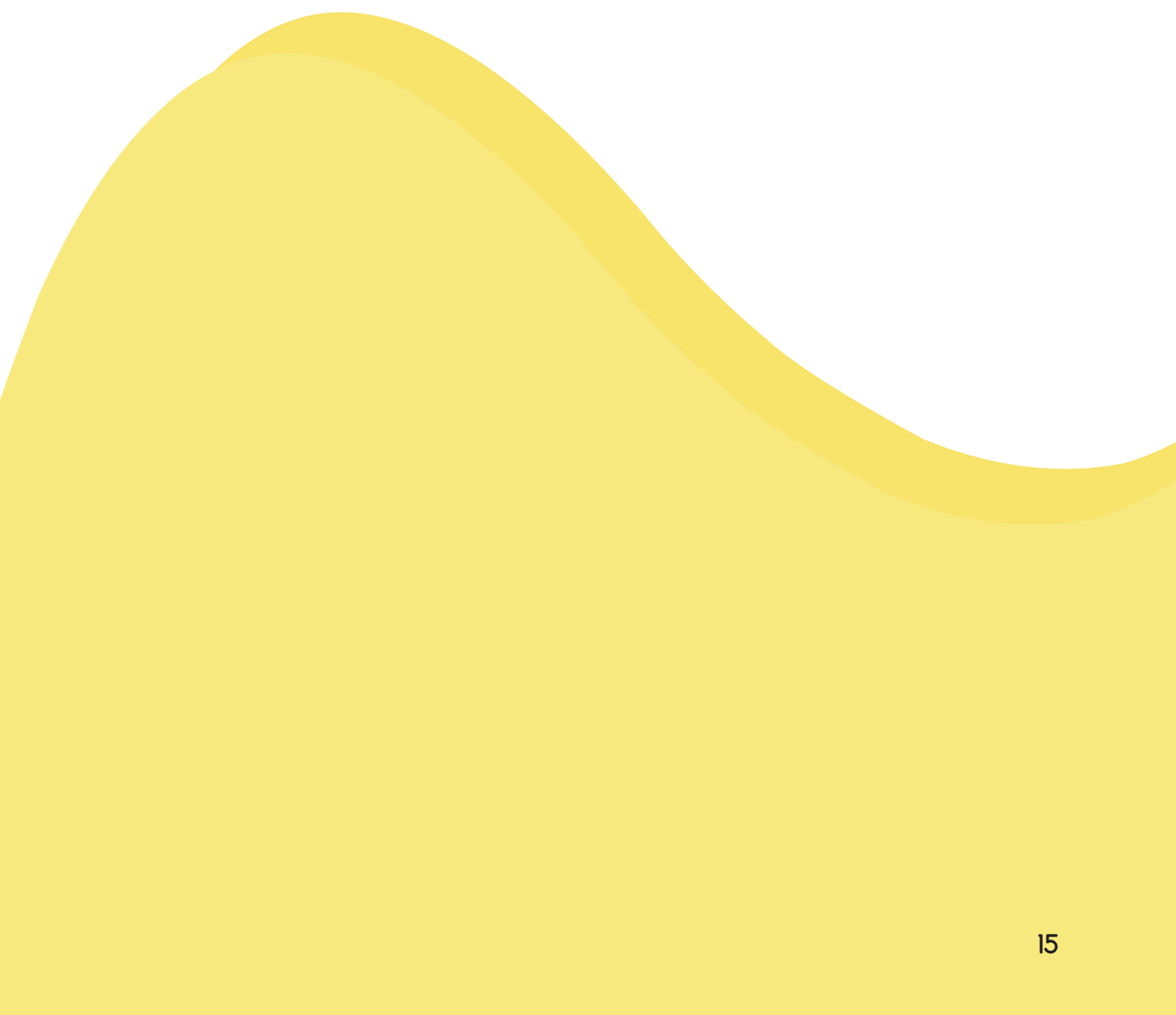

## 2.1 Problem

Currently, a large number of pupils lose interest in science during their studies in high school. In order to change their loss in interest, the government created a STEM-plan (Science, Technology, Engineering and Mathematics). Our project will be a part of this plan, by developing experimental kits fitting the physics curriculum of the Flemish government.

## 2.2 Aim

Our aim is to implement renewable energy into the physics curriculum of the Flemish school system by the use of three practical experiments. Our goal is to make pupils excited about science and place their theoretical knowledge into a real-life context.

The end result will be a complete kit of three experiments and a teaching toolkit, manufactured at the University of Antwerp. The experimental toolkit will be suitable for pupils from the 4th grade ASO in Flanders, Belgium.

## 2.3 Environment

Our project is a part of the European Project Semester hosted at the University of Antwerp. It is supervised by the Department of Product Development. The toolkit will be designed and prototyped at Campus Mutsaard. The final product has to meet the requirements of the physics curriculum of the Flemish government.

## 2.4 Interested parties

Our project involves different parties, with each different levels of interests in the development of our project. The most powerful parties are the University of Antwerp and the Sint Willebrord school. The university hosts the EPS-programme and offers us a workshop to realise our experiments. Regan Watts is our project supervisor at the university, he follows up the project on a weekly basis. The final results of our project will be tested at the Sint Willebrord school, there we will perform an usability test with the pupils of Tinne in her class. Besides the location, she provides us with information and tips about the educational part of the project.

## 2.5 Resources

The main resource of this project is our team itself. Our team consists of five students with international backgrounds, four industrial design students and one environmental engineer student. The team is supported by the project supervisor, Regan Watts and physics teacher, Tinne Van Kogelenberg and curriculum expert, Dennis Dewit. Tinne is a high school physics teacher and the experiments were tested during one of her physics classes. Dennis assisted us with the exercises and curriculum related problems.

Currently, it is the third year that the Energy Wizards project exists. As a result, we can look into the results of the previous years and learn from them. In order to construct the prototypes, we can use the workshop at Campus Mutsaard and all its equipment. Additionally, the project can use the remaining subsidy from previous years granted by the Flemish government

Fig. 2.1

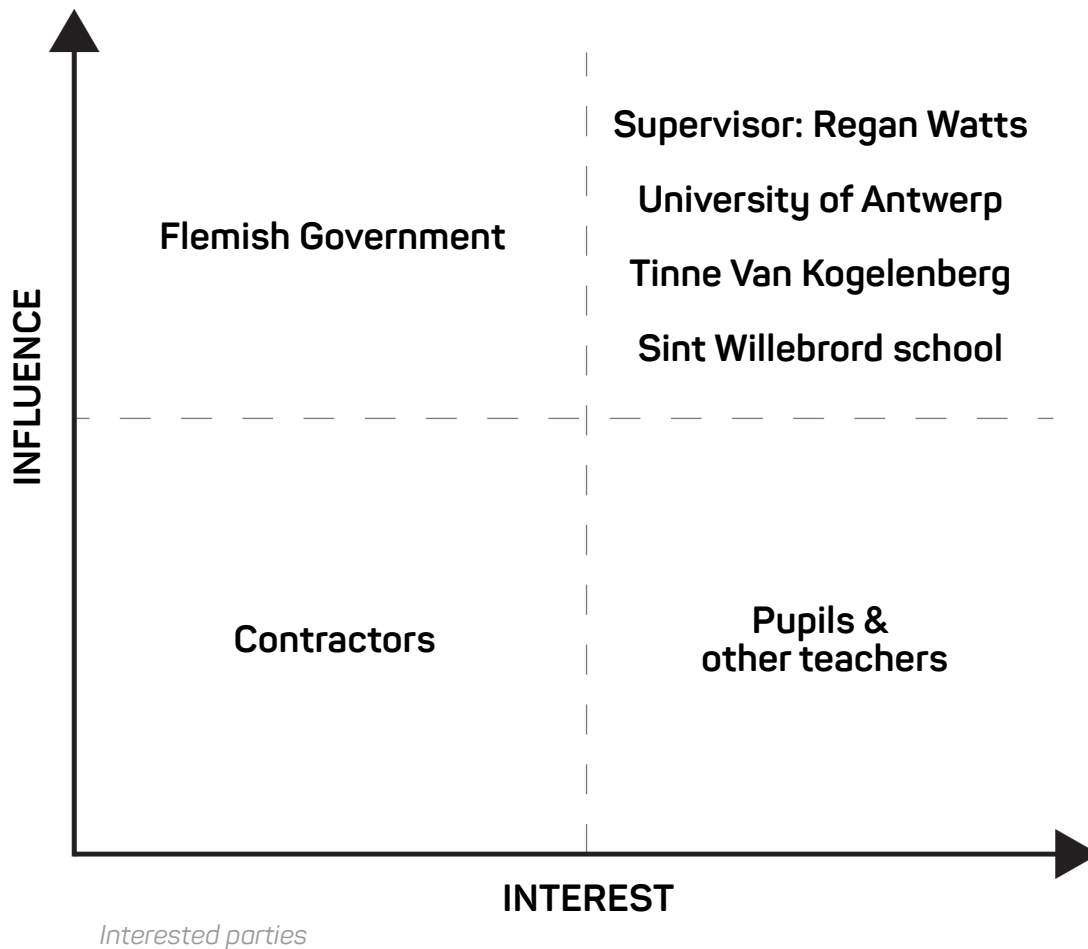

(Department of Education and training). The Energy Wizards started in 2017 with EON. In order to make science more interesting, they developed a windmill as part of a STEM inspired workshop. In our project we designed a windmill as well; EON was one of our main inspirations. We used their knowledge and final report to optimize our own design. Moreover, we were able to compare our results because their end product was available for us to test.

The group H<sub>2</sub>OME was the successor of EON, they developed a solar thermal experiment and the beginning of a hydropower experiment. We also tested their prototypes

and studied their results as well as findings to optimise our own experiments. The solar thermal we created follows the same principles as the one of H<sub>2</sub>OME, but with a better design. However, in order to develop the hydropower experiment we started with a blank canvas because we intend to include a vortex in our design.

All things considered, we had a considerable amount of resources to help us succeed in our goal to develop a complete kit of three science experiments.

LOGO'S - HAQILOGO'S

# BRANDING

- Logo + Icons

- Mock-up

- Look & Feel

  - Materials

  - Color Scheme

- Visual Language

- Branding book



# 3. Research





## 3.1 Market research

After analysing the STEM toy market, we came to the following conclusions that will be considered in defining the characteristics of our product.

First of all, we will talk about the educational toy kits, all the products are focused on eight years old kids; we did not find any toys for high school students from 14 to 18 years old. This result shows us that we have a place in the market for our STEM-kit in our target group.

The research has also shown that there is a lack of variety between the different products and almost all of them require building a predetermined construction with similar experiments in it, as we can clearly see in the solar energy kits.

Finally, all the toys have an instruction booklet about how to assemble the experiments but without explaining the science behind them, as they are all designed to be used at home instead of in a classroom.

For the STEM kits, we found that all the products provide classroom activities, a teacher's guide and moreover offer more than one experiment in each kit. However, not all of them have an introduction to the topic.

One aspect we would like to highlight is that even though the kits offer more than one experiment, they cannot be modified for teaching another topic.

## 3.2 Topic research

The topic research gave us useful information on the working mechanism of the windmill, solar thermal heater, and the hydropower turbine. The study also assisted our team to better understand the concept of the renewable energy that would be demonstrated in the experiment and see the challenges as well as requirements that we have to fulfil. Finally, after sessions of brainstorming, we could reach a conclusion on what would be feasible to achieve and have a visualization of our final models.

## 3.3 Curriculum research

This project is a part of a STEM promoting project. In order to define the goals, we researched on different websites that provide the resources to conduct STEM. This list presents a short overview of the main principles.

### **STEM principles:**

- Students' prior knowledge: it can be used as a foundation for learning new things.
- Organizing information: when students can link the new knowledge to things they already know, they will apply and understand the new information better.
  - Applying the knowledge: challenge the students to apply their learned skills and knowledge.
  - Students' motivation: it raises the quality of the learning process.
  - Effective feedback: challenge them to try and redo things while providing them with feedback. Feedback will enhance their learning process.

- Self-directed learning: challenge the students to work together and self-assess their work.

## Curriculum

The main target group of our project are pupils of the 4th grade ASO. In order to perform the experiments in class, they have to follow the learning objectives of the Flemish government.

The topics in the physics curriculum for the 4th grade are:

- Energy, work and power
- Pressure and gas laws
- Heat-energy
- Phase transitions

The book 4.2 Interactie ET2012 is the book used in the classes of the school where we tested our experiments. This book showed us the level of knowledge we can expect of the pupils and what kind of exercises they usually solve.

## 3.4 Previous Energy Wizards projects

Our main focus in this research was to know and understand the projects developed by the previous Energy Wizards teams, and to evaluate and test the products to identify possible improvements.

From the reports of each team, and also from the tests that our team performed with every experiment, we drew some conclusions that guided us to in the development of this new and updated Energy Wizards project:

## Windmill

### Tests

- Prototype aesthetically pleasing and graphic materials well designed;
- No packaging;
- Blades different from the conventional windmill;
- The blades connections could be improved functionally and aesthetically;
- The launching device is not the best solution to use as an example of an application of the energy generated.

### Report

- Even though the graphics materials have a great design, not all the students read the texts before starting the experiments;
- The workshop exceeded the class hour;
- Some components must be more self-explanatory.

Fig. 3.1



EON Windmill

## Solar thermal

### Tests

- Lack of product design in the solar panel;
- Poor graphics materials;
- No packaging;
- No element or context to apply and explain the uses of solar energy;
- Inefficient method to fill and clear the tube with water;
- The toolkit does not provide all the necessary items to the experiment.

### Report

- Water spillage when it is poured into the tube with the funnel;
- Materials used to build the prototype were not appropriate, once the heat of the light bulbs distorted them;
- The level of the exercises sheets was too advanced for the 4th grade students;
- Lack of time to solve the problems during the class.

Fig. 3.2



*H<sub>2</sub>OME Solar heater*

## Water turbine

### Tests

- Lack of product design in the turbine and the house;
- The quality of the final product is unsatisfactory. The vinyl tape, the visible wires, and no painting make the prototype looks unfinished;
- The team should have used the brand elements and colours in the prototypes;
- Poor graphics materials;
- No packaging;
- A large number of components to the students to handle, while they had to take notes of the results.

### Report

- To improve the electronic device that displays the results of the experiment that should be waterproof;
- To increase the number of turbines available to the students.

Fig. 3.3

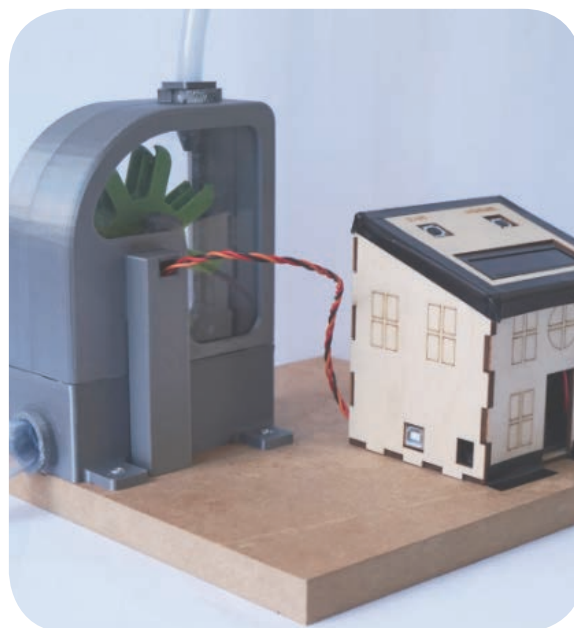

*H<sub>2</sub>OME Water turbine*

## 3.5 Teachers: Tinne Van Kogelenberg and Dennis Dewit

In order to better understand the target group of the project (number of students, their physical-mathematical level, their ages and so on) we had a meeting with Tinne Van Kogelenberg, who teaches physics at the Sint Willebrord Heilige Familie School, in Berchem.

Firstly, we specify that the age of the students will be from 14 to 18 years old.

Then, the general objectives consist of learning to investigate, concepts about science and society as well as measuring graphs.

Subsequently, she explained how experiments are solved in the laboratory classes, the conclusions she has reached as a teacher and small tips that have helped us to better understand the project from the educational point of view.

In the same way, Dennis Dewit, an expert in physics curriculum, has collaborated in the writing of the exercises that we have implemented during the workshop, owing to his experience in teaching.

*An extended version of all the research presented in this chapter can be found as an appendix (Appendix D, E and F)*



# 4 Our Project



## 4.1 Design brief

### Specifications

- 3 experimental toolkits for 3 different workshops.
- Duration of the experiment is 50 minutes.
- The target group are pupils of the fourth grade (15-16 years old).
- The main topic of the 3 workshops is renewable energy.
- One experiment is about wind energy.
- One experiment is about solar energy.
- One experiment is about hydropower.
- The workshop is to be held during a one-hour physics class.
- The workshop is supervised by a science teacher.
- The pupils work in groups of two people.
- The workshop is focused on the 4th grade ASO curriculum.
- The workshop involves all STEM disciplines.
- The workshop is conforming to the Flemish physics curriculum

### Design Items

- Design an experiment about wind energy.
- Design an experiment about solar energy.
- Design an experiment about hydropower.
- Design a house that can be powered by the three experiments.
- Make for each experiment a handout with guidelines for the teacher.
- Develop an introduction video for each experiment (2-3 minutes).

### Design Drivers

- Make pupils excited about science.
- Place the students' theoretical knowledge in a real-life context.

## Wind energy experiment

### – design items:

- Design a windmill:
  - That has interchangeable blades.
  - That can be assembled and disassembled.
  - Which you can change number and the angle of the blades.
  - That can generate a measurable voltage.
  - That can be powered by a fan.
  - That fits the FLOW-design style.
- Design a link to the house.
- Make a handout for the students which explains the steps to follow in order to conduct the experiment.
- Make a handout for the students which contains exercises related to the experiment and the curriculum.
- Make a handout for the teacher which contains guidelines of the experiment and the solutions of the exercises.

## Solar energy experiment

### – design items:

- Design a solar heater:
  - That has interchangeable light bulbs.
  - That can be assembled and disassembled.
  - Which has good insulation.
  - Where the water spillage and use are kept to a minimum.
  - Which is safe in use.
  - That fits the FLOW-design style.
- Design a link to the house.
- Make a handout for the students which explains the steps to follow in order to conduct the experiment.

- Make a handout for the students which contains exercises related to the experiment and the curriculum.
- Make a handout for the teacher which contains guidelines of the experiment and the solutions of the exercises.

## Hydropower experiment

### – design items:

- Design a water turbine:
  - That has interchangeable nozzles.
  - That has interchangeable propellers.
  - That contains a vortex.
  - That can be assembled and disassembled.
  - Where the water spillage and use are kept to a minimum.
  - Where you can change the flow of the water.
  - That can generate a measurable voltage.
  - That can be powered by a drill.
  - That fits the FLOW-design style.
- Design a link to the house.
- Make a handout for the students which explains the steps to follow in order to conduct the experiment.
- Make a handout for the students which contains exercises related to the experiment and the curriculum.
- Make a handout for the teacher which contains guidelines of the experiment and the solutions of the exercises.



## 4.2 Marketing

### Branding

#### Name

The name of our corporate identity should connect the three experiments, windmill, solar heater and water turbine and also should be related to Renewable Energy and Nature.

FLOW is a short word, catchy and easy to pronounce in a wide range of countries. Furthermore, flow means movement, flux and in this case, the circulation of the water and wind that are essential for the functioning of the experiments.

#### Logo

The final logo is simple, youthful and minimalist. The wave unites the letters, while it represents the water, wind and heat flux. The leaves illustrate nature and together with the wave, they cause the feeling of dynamism and movement to the brand. The colours and the rounded corners in the letters and elements make the logo more playful.

The colour palette has saturated and youthful tones to contrast with the grey that is more serious and mature, this balance between the colours prevents the logo from looking childish.

The 'FLOW ©' brand is easily applicable since it was designed to be used in different versions. In addition to the main version and the symbol version, the logo can also be monochrome, black and white and shades of grey.

*An expanded version of the brand book is annexed to this report (Appendix J).*

4.1



*Logo main version*

4.2

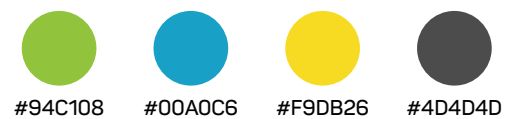

*Colour palette*

4.3



*Logo variations: shades of grey, white and monochrome (black)*

4.4



*Symbol version and different variations*

## Communication

In the FLOW workshop packaging there are supplementary materials, designed according to the visual identity of the brand.

The materials included in the final product are:

- **Videos:** step-by-step images to show how to assemble all the components to build the products, and how to perform the experiment.
- **Instructions:** written information to consult after watching the video, to help to assemble the components and to perform the experiment.
- **Exercises sheets:** list of exercises about the topic and questions to be solved with the results obtained in the experiments.

The materials that support the final product are:

- **Teacher's guide:** offers information to the teachers, the extra materials necessary how to prepare the workshop and how it will work.
- **Teacher's exercises sheets (model answers):** exercises solved for the teacher.
- **Brochure:** graphic material designed to advertise the products and show all the information about them.

4.5

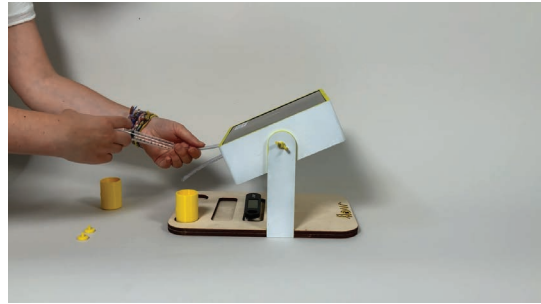

Video - solar thermal

4.6



Instructions

4.7

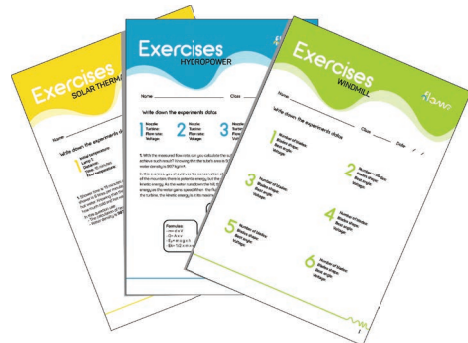

Exercises sheets

4.9

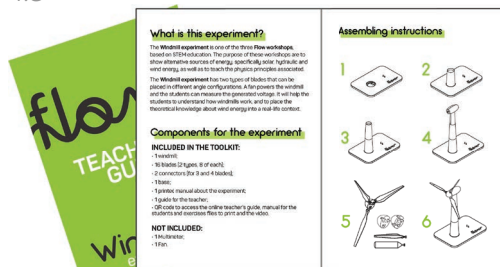

Teacher's guide

4.8



Brochure

The full version of the documents can be found as an appendix (Appendix K).

## 4.3 Concept generation

The purpose of this project is to create an educational kit constituted by three experiments that implement renewable energy into the physics classes and to promote STEM topics. In order to achieve our goal we started with brainstorming sessions considering the design brief specifications, then we chose the best ideas and developed them to study their viability so we could start the prototyping process and the first tests to verify the idea or make adjustments if necessary.

### Main concepts

#### Windmill

The experiment consists of a windmill with the possibility of having different types of blades and angle configurations. A fan powers the windmill and the students can measure the generated voltage.

#### Solar thermal

The experiment consists of a solar thermal panel with different configurations in which the students can study the efficiency and the heat transfer by measuring the temperature difference of the water.

#### Water turbine

The experiment consists of a water turbine that uses water vortex as the power source. After assembling the experiment, the students can change the nozzles, the propellers, and the flow of the water, powering it with a drill.

#### House

The house's main function is to connect the three experiments and visualize the energy produced through the different LED lights located on the inside and controlled by an Arduino.

4.10



Brainstorming session

4.11

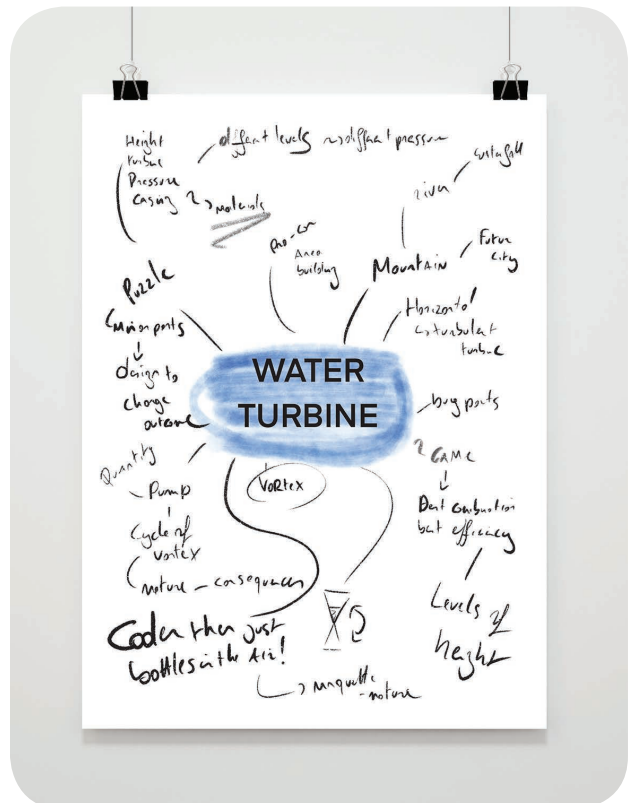

Water turbine brainstorm

## 4.4 Windmill

### Ideation

Design a windmill, consisting of different parts with different setups. It has to create an open voltage that can be measured and needs to be easy to use.

The windmill concept is not new, we optimised the design of the EON-team from 2017. EON's windmill also consists of different parts that the students have to assemble. However, it differs in two main points from our concept.

First of all, in their concept the pupils have to design their own blades from paper, while we provide two types of blades made of PLA. Secondly, we use the generated energy to charge a house instead of a launching mechanism for launching planes through the classroom.

These are the main concept differences between EON's windmill and our own design. However, the execution of the shared idea to a high-fidelity prototype is our own. We were inspired by EON but tried to follow our own path while learning from their mistakes and successes.

At the start of the project, we participated in a day full of brainstorming. We wrote all our thoughts and ideas on a large sheet of paper. In this phase, everything is possible, so there is no judging involved.

After listing all our ideas, we went home to individually sketch and develop some ideas. These sketches were later presented in group, where we chose the best one as a base for our further CAD-model.

4.12



*Windmill's sketch*

## Prototyping

From the beginning, our goal was to test our final product in a real class with actual pupils. So, a significant part of this project was devoted to the iterating process called "prototyping". The prototyping process was an enjoyable but extensive phase. It was time-consuming for a couple of reasons:

Firstly, the technique used was "3D-printing". In order to print, you first need a correct CAD-model, which you then convert to an STL. The accuracy of your CAD-file will define how precise your print and its connections are. Secondly, printing itself consumes a considerable amount of time. The printing could take two hours to twenty-eight hours, depending on the volume and orientation of the print. When the print is finished we try to test it as fast as possible for the reason that if it is not perfect yet we can start a new print as quick as possible. In order to make the windmills' parts we only used 3D printing except for the base and the generator. The base is made from plywood which we laser cut in the shape we required. The generator is a stock part we ordered online.

### Materials we used:

- PLA;
- Plywood.

### Techniques we used:

- 3D-printing: Almost all parts are printed in the workshop at the university.
- Laser cutting: The base plate was laser cut in the workshop at the university.
- Soldering: To connect the engine to electric cables we had to sold them together with some tin.

4.13

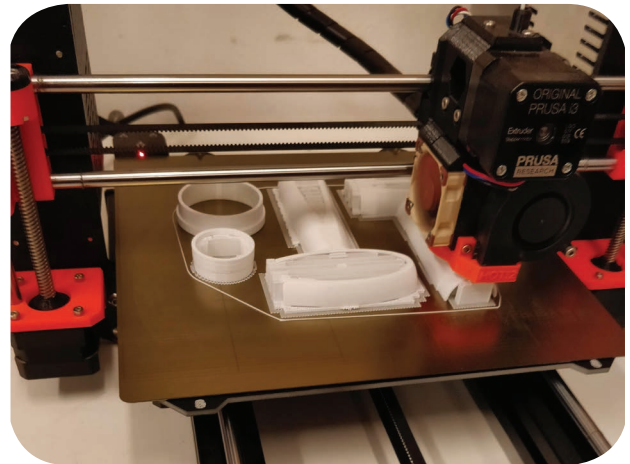

3D printing

4.14

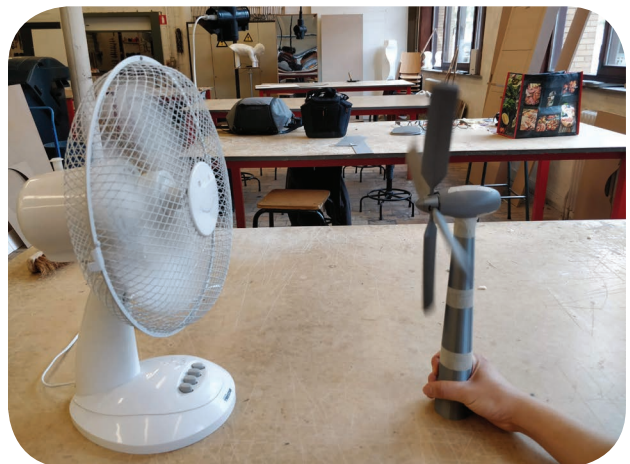

Testing first prototype

4.15



Final tests

## Final design

The windmill consists of different parts, which the pupils must assemble. They have the opportunity to create their own configuration of blades. The students can choose two types of blades, the angle in which these are placed and decide the number of those blades. After finding the best configuration, they connect the windmill to the house. The windmill provides energy, the more energy is delivered to the house, the more lights are ignited inside. While searching for the best configuration, the students measure and register the generated voltage of each setup. The measurements will be used in the exercises included by the windmill.

### What did we improve from EON?

4.16

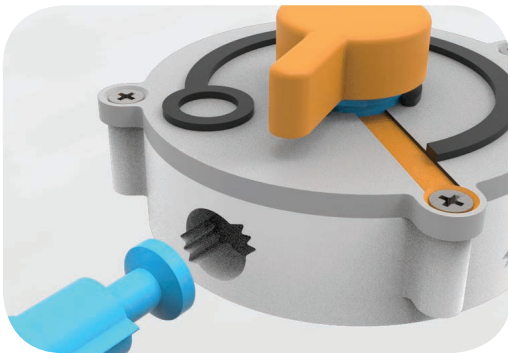

Blade's connection



Cable's connection



Blade's design

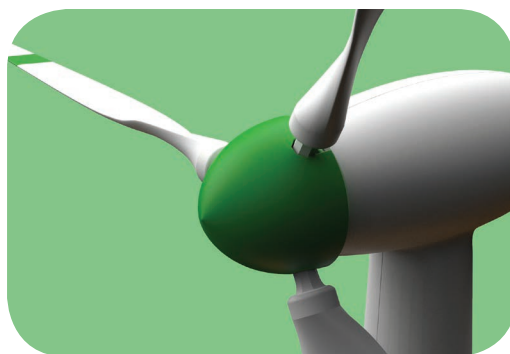

*Eon FLOW comparison*

# Renders

4.17



Render windmill

4.18



Render exploded view

4.19

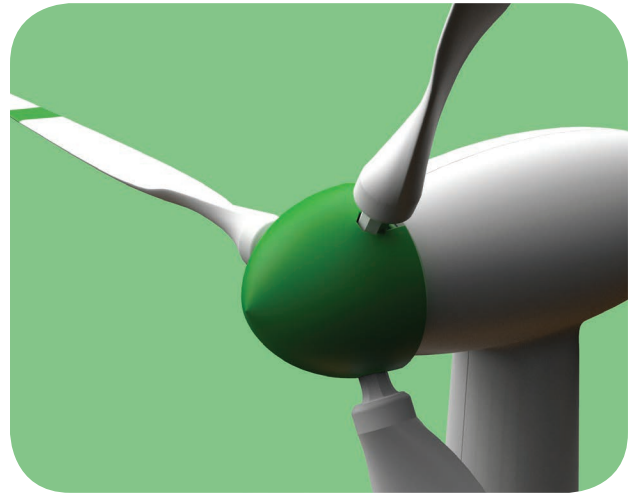

Render blades

4.20



Render connection

4.21

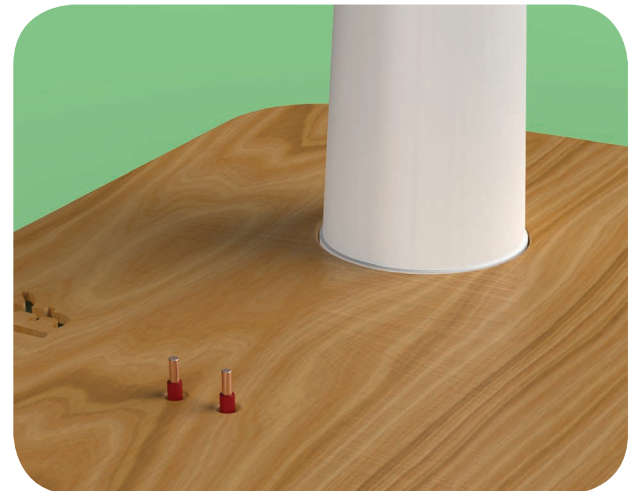

Render base

# Prototype

4.22



Prototype windmill

4.23



Components

4.24

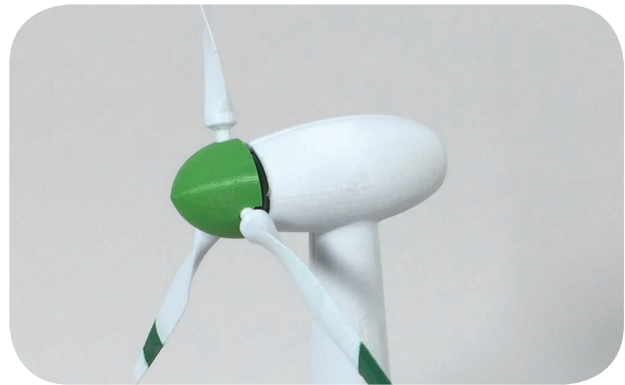

Connector

4.25

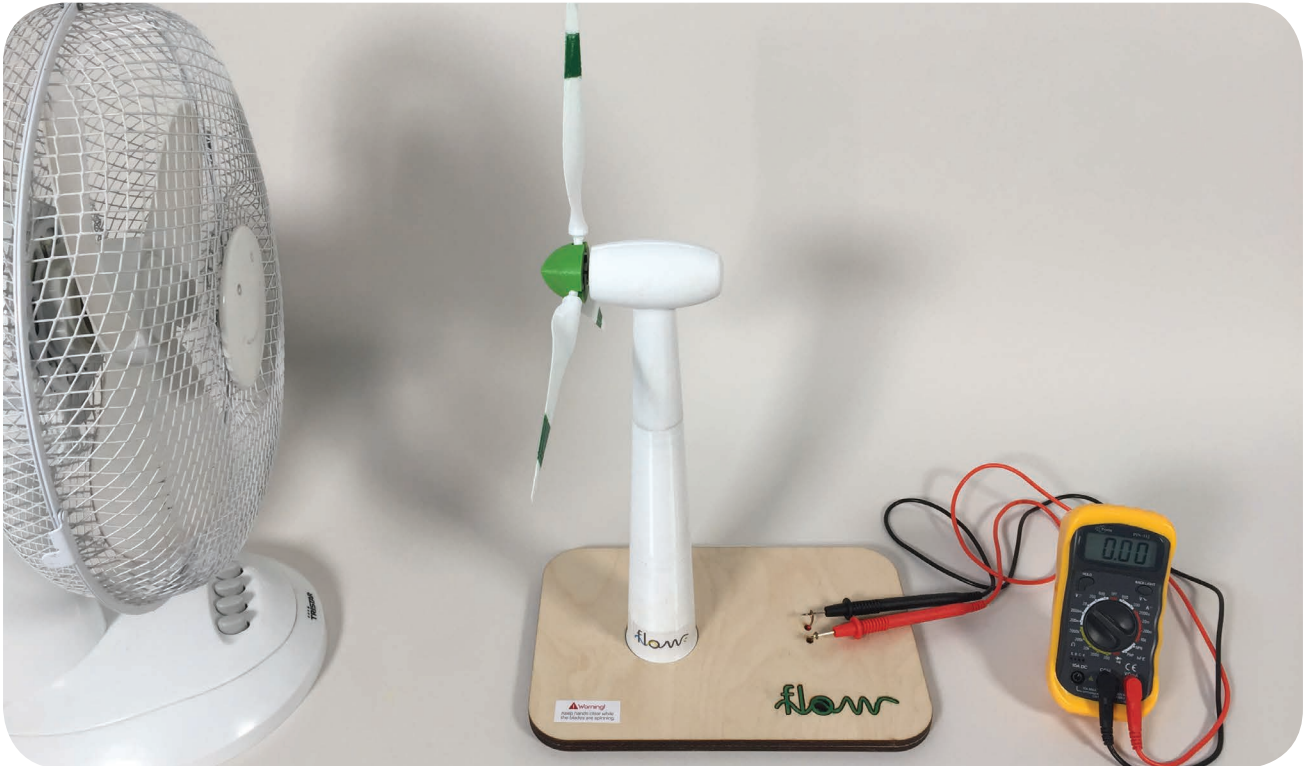

Composition



## Components

### The toolkit includes:

- 1 windmill;
- 16 blades (2 types, 8 of each);
- 2 connectors (for 3 and 4 blades);
- 1 base.

### Not included:

- 1 Multimeter;
- 1 Fan.

## Supplementary materials

In the packaging box, we provide these supplementary materials:

- A manual of the experiment with the schedule and steps for the students;
- A paper bundle of exercises necessary to complete the experiment;
- A guide for the teacher with all the information about the experiment;
- QR code to access the online teacher's guide, manual for the students and exercises files to print and the video.

## Experimental procedure

### Timetable

- Introduction: 10 minutes.
  - Video;
  - Unboxing;
  - Assembling the experiment.
- Testing and measurements: 25 minutes.
- House connection: 10 minutes.
- Ending the experiment: 5 minutes.

## Steps

- 1-** Assemble the experiment following the instructions in the video;
- 2-** Choose the number and type of blades for the windmill. Determine the angle you want them to be positioned in. Assemble the blades in the windmill;
- 3-** Place the fan 20 centimetres away from the windmill' base. Turn it on;
- 4-** Measure the voltage with the multimeter and write down the measurements;
- 5-** Test the 2 types of blades in different configurations, with 2, 3 or 4 blades in each angle, then, measure the voltage (in milli-volts) generated;
- 6-** Write down in the exercises sheets the voltage for each configuration in the best angle;
- 7-** Complete the additional exercises at home;
- 8-** Connect your best configuration to the house.

*The worksheet of the windmill, technical drawings, the storyboard of the video and the full version of all the supplementary materials can be found as an appendix (Appendix K, L and N).*

## Assembling instructions



Connect the cables in the base



Attach the first part of the tower



Attach the second part of the tower



Connect the cables in the hub and then attach it to the tower

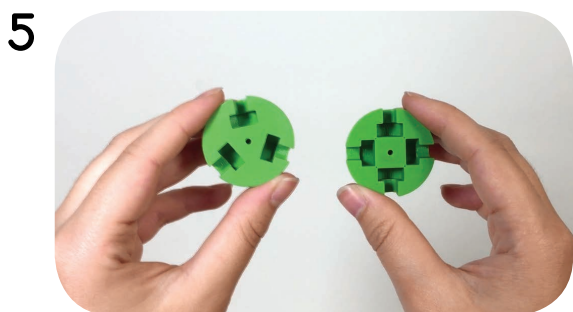

Choose the number of blades



Choose the type of the blades



Determine the angle of the blades



Assemble the blades in the windmill

## 4.5 Solar thermal

### Ideation

Design a windmill, consisting of different This experiment aimed to improve the design, the efficiency and the exercises sheets of the previous solar thermal, from H<sub>2</sub>OME- the Energy Wizards team from 2018.

To enhance the insulation of the panel we changed the material of the box, instead of MDF we used plywood, it is an assemblage of wood veneers bonded together that maintains better the heat. We also changed the tube to one with a smaller diameter and diminished its length, to reduce the water flow and, consequently, to heat faster. Changing the distance between the turns of the tube improved the heater as well.

Instead of using the same light bulbs as the previous group, the new toolkit has one 36W light bulb and one 53W. The distance between the light bulb and the panel also changed, this improved experiment uses a desk lamp and the students can combine different distances with the different voltages and compare the results.

The new solar thermal design matches with the visual identity of the brand, it is

minimalist. Yellow is the colour chosen for this experiment, it is one of the three main colours of the brand and it represents the sun. The wood texture, the white paint and the coloured details create visual unity among the experiments, they follow the same aesthetics, changing just the main colour. Furthermore, the new design also made assembling the parts easier.

The worksheets, we based the exercises on the physics curriculum of the Flemish Government and the curriculum expert Dennis assisted us, assessing the level of difficulty of the questions.

The final solution is a solar thermal panel with better insulation where the students, with the help of the toolkit items, perform the experiment and then analyse the efficiency and heat transfer by measuring the difference of water temperature.

The highest water temperature in each group should be tested on the house that will be connected to an Arduino, and then the students could see the practical application of the solar thermal in the daily routine.

4.26

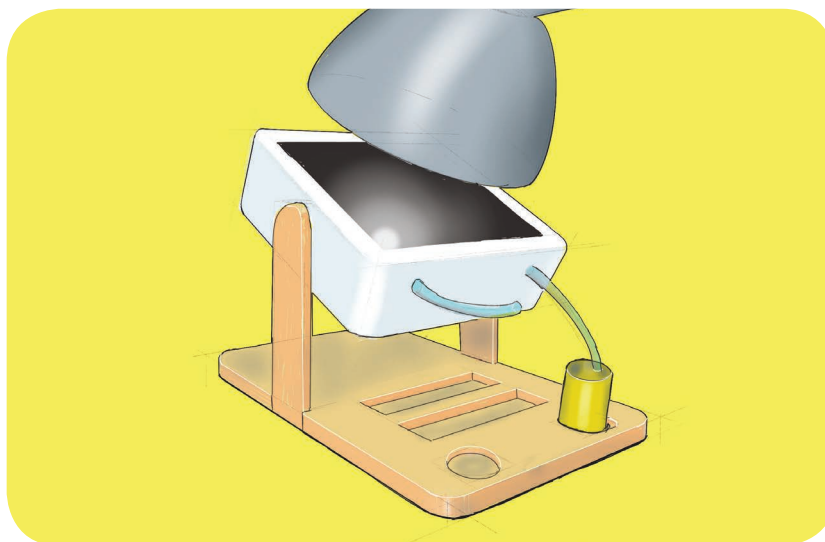

*Solar thermal's sketch*

## Prototyping

After defining the changes and improvements in the experiment, we built the prototypes. The structure of the first version was made of 8mm plywood and cut in the CNC router, but the finish was not good, so we used different plywood of 6mm and laser cut it. In order to obtain better insulation from this new wood, it was glued two wood sheets in the wall of the box.

The squared shape was maintained from the previous year version since it works. In this way, the tube could be rolled evenly and the water could flow, also the heat warms the water in the tube equally, what would not happen if the box was rectangular. Once we used a smaller diameter tube and diminished its length, we could also build a smaller box.

Sponges were glued inside the box, because they help to insulate the panel, and then together with the tube they were painted in black, the colour that absorbs more heat. In order to maintain the tube in the place and not touching itself, we laser cut a structure with holes and we also painted it in black.

Finally, the outside of the box was painted in white and the details in yellow, the chosen colour for this experiment. The corks and the measuring cups were 3D printed in yellow PLA filament, stickers of the brand were stuck in some toolkit items and the plexiglass was glued in the surface.

### Materials we used:

- Plywood;
- Plexiglass;
- PLA;
- Polyurethane foam;
- Flexible PVC tube.

### Techniques we used:

- Laser cutting: The base plate and the panel were laser cut in the workshop at the university.
- 3D-printing: the measuring cups and the corks were printed in the workshop at the university.

4.27

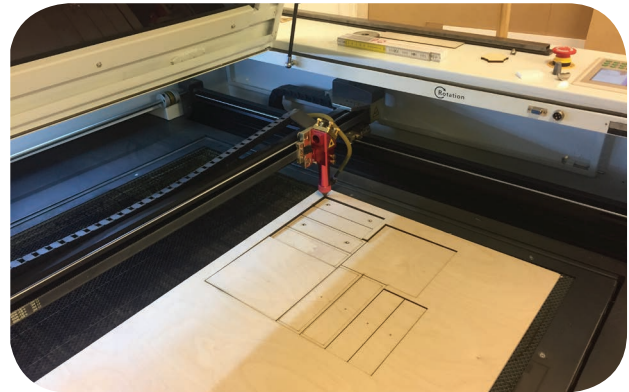

*Laser cutting the box*

4.28



*Testing the thermal*

4.29



*Painting the panel*

Final design  
Renders

4.30



Render solar thermal

4.31



Render solar thermal back

4.32

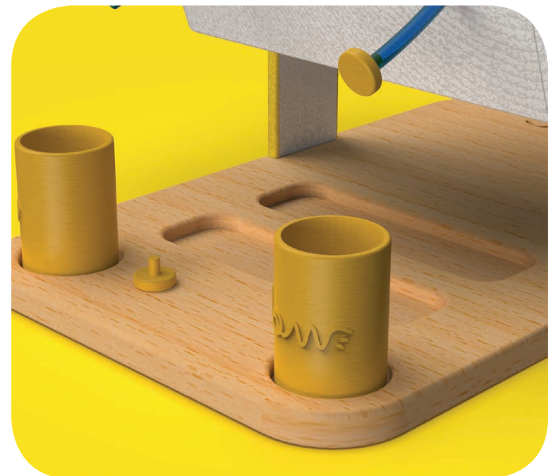

Render details

4.33



Render solar thermal front

4.34



Render solar thermal top

# Prototype

4.35



Prototype solar thermal

4.36



Composition

4.37

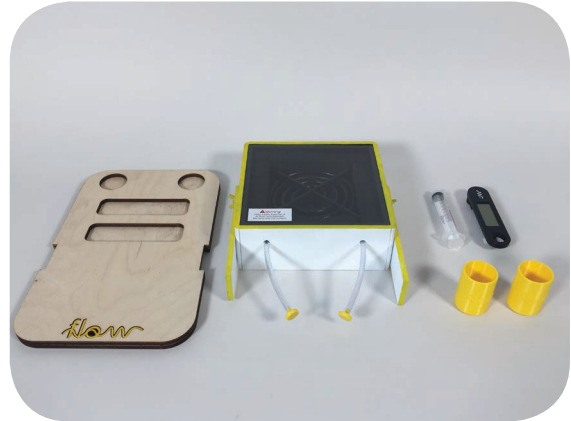

Components

4.38



Prototype solar thermal side view

4.39



Details

## Components

### The toolkit includes:

- 1 solar thermal panel;
- 1 base;
- 2 measuring cups (35ml);
- 2 corks;
- 1 syringe (10ml);
- 1 waterproof thermometer;
- 2 light bulbs (36W / 53W).

### Not included:

- 1 Desk lamp.

## Supplementary materials

In the packaging box, we provide these supplementary materials:

- A manual of the experiment with the schedule and steps for the students;
- A paper bundle of exercises necessary to complete the experiment;
- A guide for the teacher with all the information about the experiment;
- QR code to access the online teacher's guide, manual for the students and exercises files to print and the video.

## Experimental procedure

### Timetable

- Introduction: 10 minutes.
  - Video;
  - Unboxing;
  - Assembling the experiment.
- Testing and measurements: 30 minutes.
- House connection: 5 minutes.
- Ending the experiment: 5 minutes.

## Steps

**1-** Assemble the experiment following the instructions in the video. Fill one of the cups with water and measure the initial temperature;

**2-** Measure 10ml of water with the syringe and fill the tube. Pump air into the tube with the syringe to be sure that all the water is inside the box and put the corks;

**3-** Choose the 36W light bulb to start the experiment.

**4-** Set the correct distance between the panel and the lamp. Set up an alarm for 15 minutes and turn on the lamp at the same time. While waiting, complete the exercises sheets;

**5-** When the time is over, use the syringe to pour the water into the empty cup and measure its temperature again;

**6-** Put data into the worksheet and start the calculations;

**7-** Restart the experiment with the 53W light bulb. Remember to use the same distance between the light bulb and the panel to compare the results;

**8-** Use the heated water with the house.

*The worksheet of the solar thermal panel, technical drawings, the storyboard of the video and the full version of all the supplementary materials can be found as an appendix (Appendix K, L and N).*

## Assembling instructions

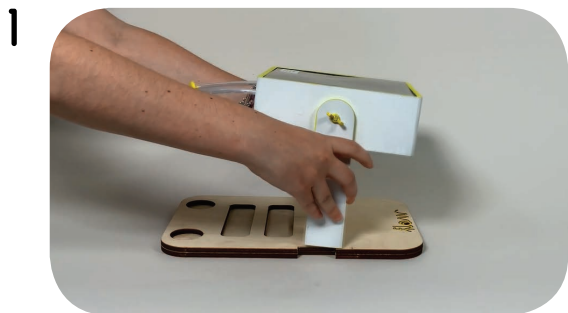

Attach the box in the base

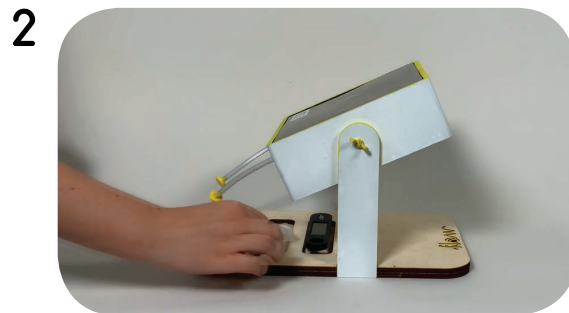

Place the thermometer and serynge



Place the cups in the base

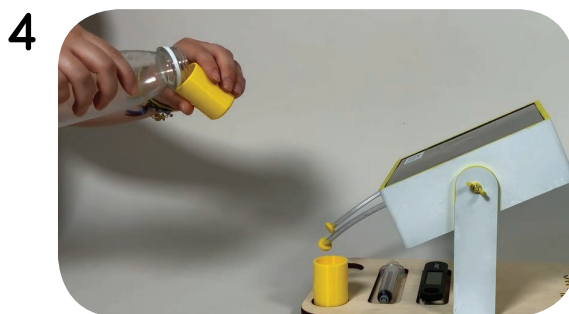

Fill one of the cups with water



Choose the light bulb

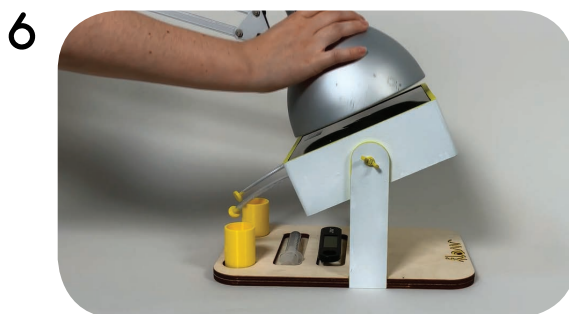

Set the lamp in front of the panel



## 4.6 Water turbine

### Ideation

In this experiment, the aim is to make the students familiarized with hydropower technology. Since the topic can be quite complicated, we aim to make the design of the model and the working mechanism as simple as we can. Also, we intend to have a reasonable size of the experiment that requires less than one meter of height. For that reason, the gravitational vortex power plant was chosen.

This new choice is different from last year, which was a Pelton turbine. In this year's experiment, the flow of water is controlled by a drill pump, which offers more stability from last year that required the students to stand on a table and pour the water inside the tube. Besides that, the experiment also

offers a selection of different turbine blade design for the pupils to test and each of these blades has contrasting efficiency. One of H<sub>2</sub>OME's mistakes from last year was the failure of the tubes' connection and it led to spillage. The experiment uses water as the fuel to power the whole system, which requires absolute water-proof material and tight connections between the components to prevent water leakage. Learning from this mistake, we found a new solution which is using standard gardening hose connections in the model. These hose connectors are purchased from the shop and they are specially made for household gardening and prevent leakage.

4.40

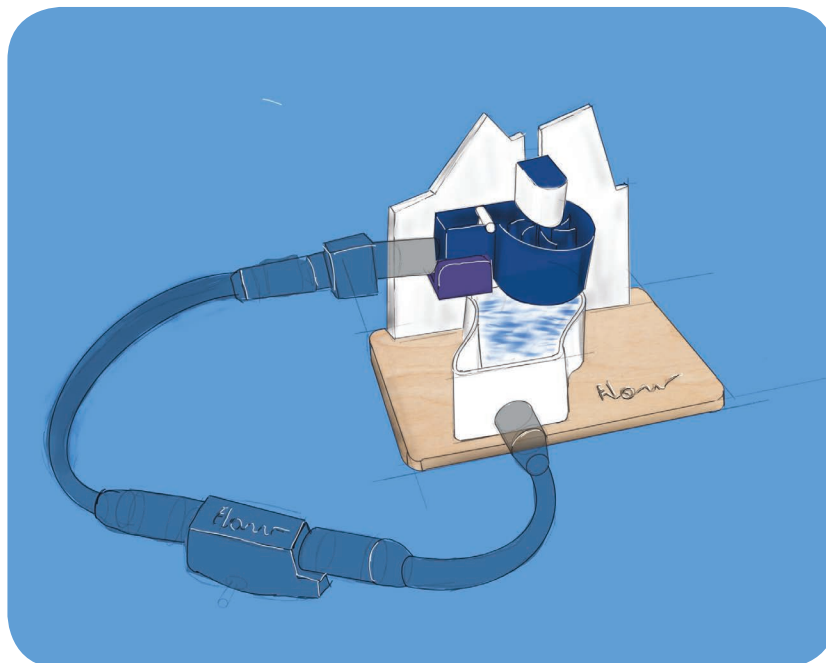

Water turbine's sketch

## Prototyping

Our first idea for the kit included a miniature mountain, water tubes, a vortex turbine, a pump, and a base. The plan was to let the water flow from the top of the mountain to the turbine blade, then the exit water was pumped back to the mountain, which created a loop. The next step was to 3D-print the turbine basin and blades using PLA plastic. The design, as well as the dimension, was conformed to the specifications in the topic research.

After that, a test was conducted to validate the design. Instead of a mountain, we used water flow from the tap to make a vortex with a flow rate meter was attached to the inlet valve of the turbine. The water started to form a vortex at the flow rate of 5 litres/minute, the vortex increased in size as we increased the water flow and spillage of water was recorded at the flow rate of 7 litres/minute.

From the test result, we concluded that in order to make the turbine to work efficiently, the flow rate should be at least at 5 litres/minute. However, after calculations, we concluded that it would be necessary height of 2 meters of the mountain to acquire such flow, which was impossible for the final design because then the experiment would be significant. After consulting with our supervisor, we decided to change the approach, the mountain is still the same, but the lack of water flow is compensated with the pump power. So as to ensure that the pump provides sufficient flow, we chose a drill pump that could create a maximum flow rate of 28 litres/minute.

Additionally, since we did not use the mountain as a water source, we had to implement a water pool on the base to contain water. From here, the pump sucked the water and regulated it in the experiment. As mentioned before, since the new model used hose connections, water leakage was

prevented, but in the test, there was some water splash around the turbine. In order to overcome this, a lid made from Plexiglas was placed on top of the basin and an orifice was created on the glass for the placement of the generator shaft. The generator also had a case to protect it from the water and the case was attached to the mountain.

The manufacturing process of the model was created by laser cut and 3D-printing. The base and mountain were laser cut, the turbine basin, blades, generator case, and water pool were 3D-printed, other materials such as the hose connectors, tubes and pump were purchased from the shop.

### Materials we used:

- PLA;
- Plywood;
- Plexiglass;
- Flexible PVC tube.

### Techniques we used:

- 3D-printing: Almost all parts are printed in the workshop at the university.
- Laser cutting: The base plate and the mountain were laser cut in the workshop at the university.
- Soldering: To connect the engine to electric cables we had to sold them together with some tin.

4.41

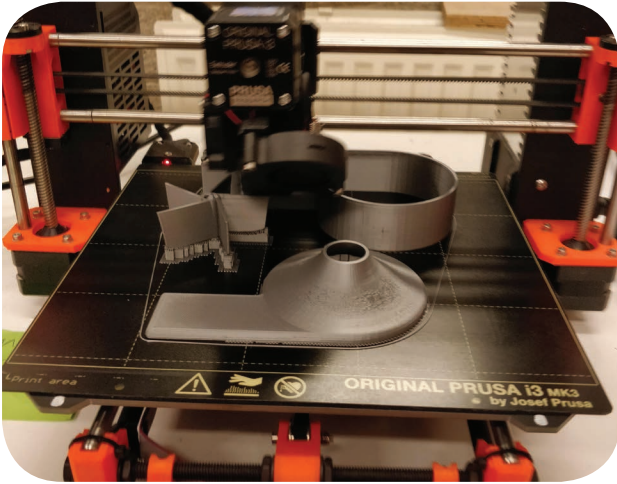

3D printing

4.42



Vortex test

4.43



Turbine blade 3D printed

4.44



Turbine blade test

4.435



Measurements

4.46



Final tests

# Final design Renders

4.47



*Render hydropower*

4.48

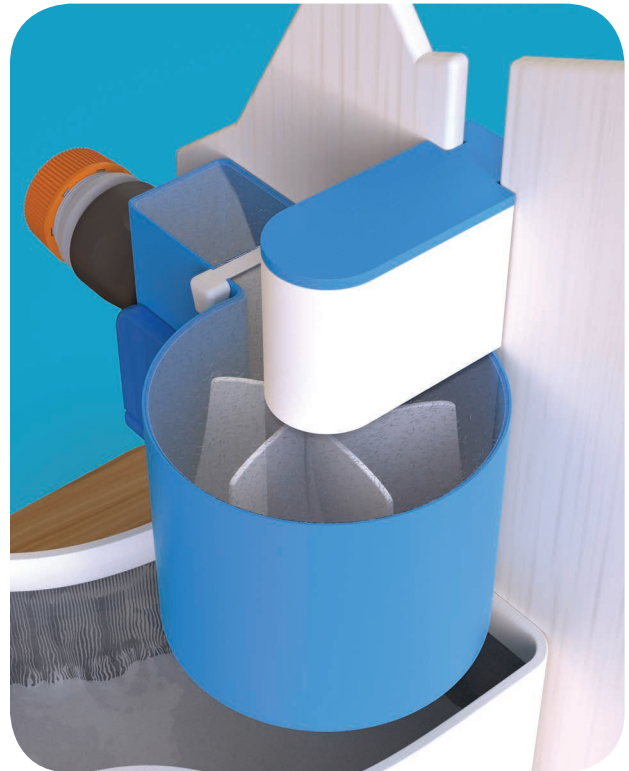

*Render details*

4.49



*Render hydropower front*

# Prototype

4.50

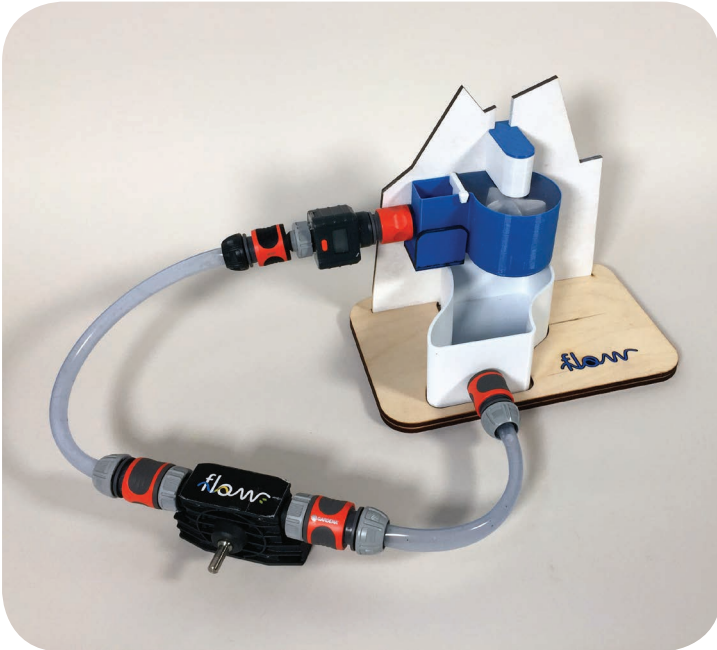

Prototype hydropower

4.51



Details

4.52

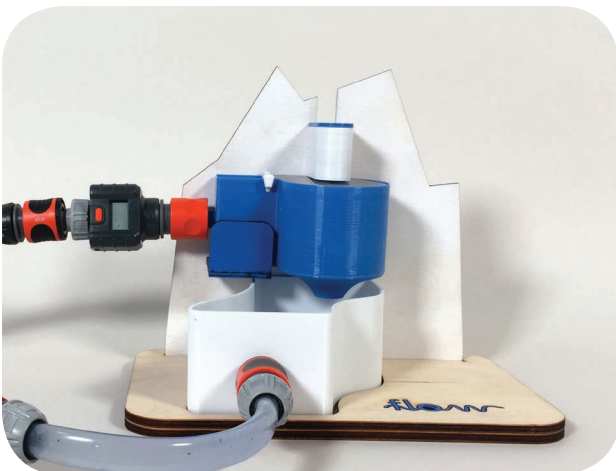

Prototype hydropower front

4.53



Components

## Components

### The toolkit includes:

- 1 turbine basin;
- 1 generator with casing and electronic wire;
- 1 glass cover;
- 1 turbine blade;
- 4 nozzles;
- 2 plastic tubes with hose connectors;
- 1 waterpool;
- 1 flowmeter;
- 1 pump;
- 1 base;
- 1 miniature mountain.

### Not included:

- 1 Drill;
- 1 Multimeter;
- 1 Volume cup.

## Supplementary materials

In the packaging box, we provide these supplementary materials:

- A manual of the experiment with the schedule and steps for the students;
- A paper bundle of exercises necessary to complete the experiment;
- A guide for the teacher with all the information about the experiment;
- QR code to access the online teacher's guide, manual for the students and exercises files to print and the video.

## Experimental procedure

### Timetable

- Introduction: 10 minutes.
  - Video;
  - Unboxing;
  - Assembling the experiment.

- Testing and measurements: 25 minutes.
- House connection: 10 minutes.
- Ending the experiment: 5 minutes.

### Steps

- 1-** Assemble the experiment following the instructions in the video;
- 2-** Choose the nozzle for the inlet valve;
- 3-** Fill the water pool with about 900 ml of water;
- 4-** Turn on the flow meter and connect the wires of the generator to the multimeter;
- 5-** Start the drill pump and observe the flow meter. Try to keep the flow constant, then take note of the flow rate and output voltage;
- 6-** Choose a different nozzle and repeat the steps as the above;
- 7-** Complete the additional exercises at home;
- 8-** Connect the best configuration to the house.

*The worksheet of the water turbine, technical drawings, the storyboard of the video and the full version of all the supplementary materials can be found as an appendix (Appendix K, L and N).*

## Assembling instructions

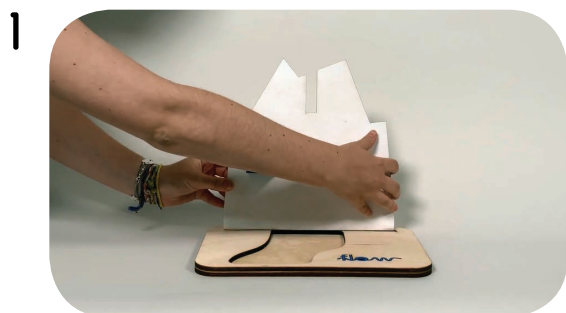

Assemble the mountain in the base

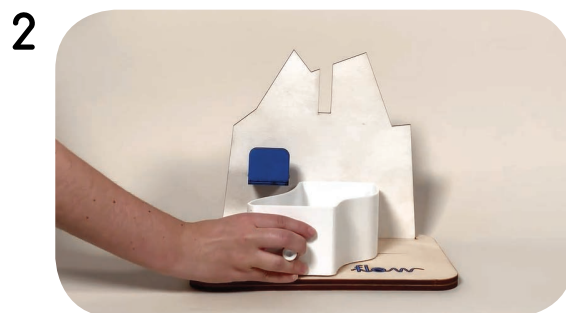

Place the waterpool



Insert the chosen nozzle

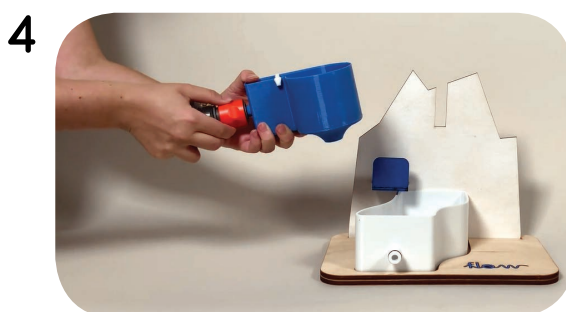

Attach the flowmeter to the basin



Place the turbine basin

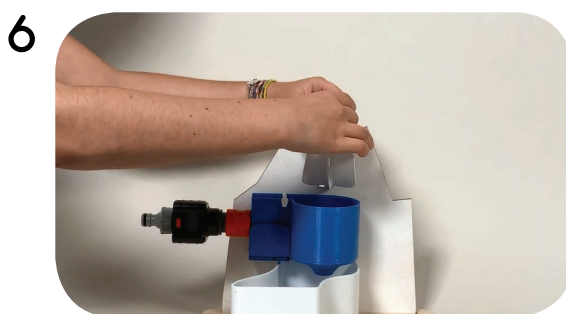

Place the generator



Attach the pump to the drill

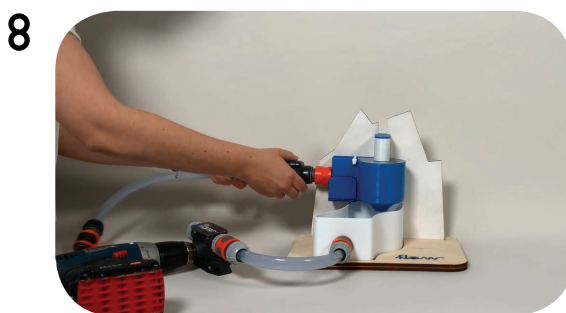

Connect the two tubes

## 4.7 House

### Ideation

We designed a house with the aim to connect the three experiments. As a device to visualize the energy that the three experiments generate and help the students understand the concepts more easily since a house is something each student is familiar with.

The house is entirely furnished in order to make it more realistic, and inside of some furniture there are LED lights, controlled by an Arduino that reads the voltage that will activate or change the colour depending on the load of voltage obtained.

### Prototyping

#### Base

The base is composed of two laser cut sheets of plywood glued together with the Flow logo and painted in colour black. The wood sheet on the top has two spaces where the house structure and the Arduino are placed.

#### House

We intended that all the interiors of the house could be seen from the outside so the LED lights could be easily perceptible, therefore we used rectangle Plexiglas for the walls and glued them on the structure. For the structure, we laser cut plywood rectangles and glued them together forming a corner.

#### Furniture

All the furniture is scaled and 3D printed with PLA filament.

4.54

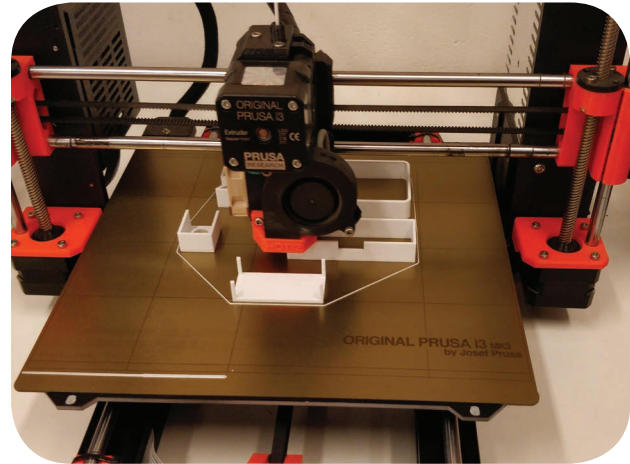

*3D printing de furniture*

4.55



*Building the house*

4.56

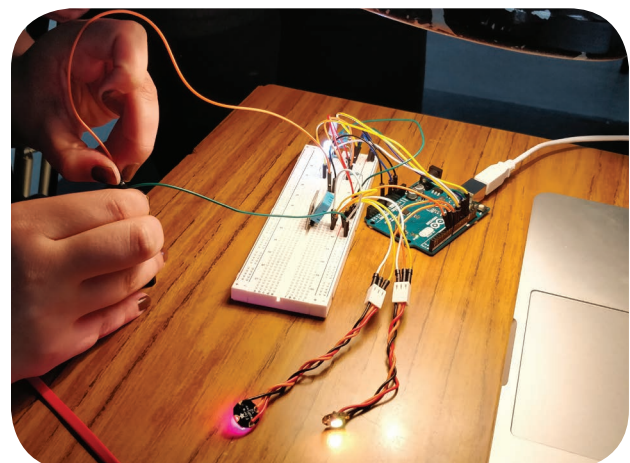

*Testing Arduino*



## Final design

### Renders

4.57

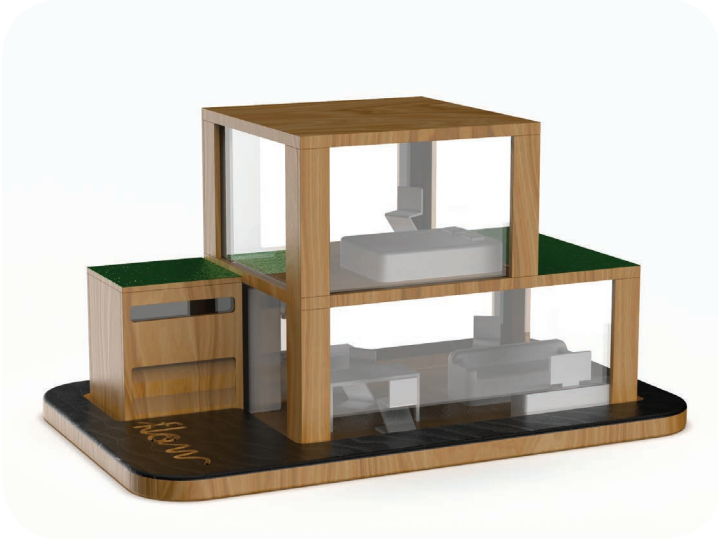

Render house

4.58



Diagonal view

### Prototype

4.59



Prototype house

4.60

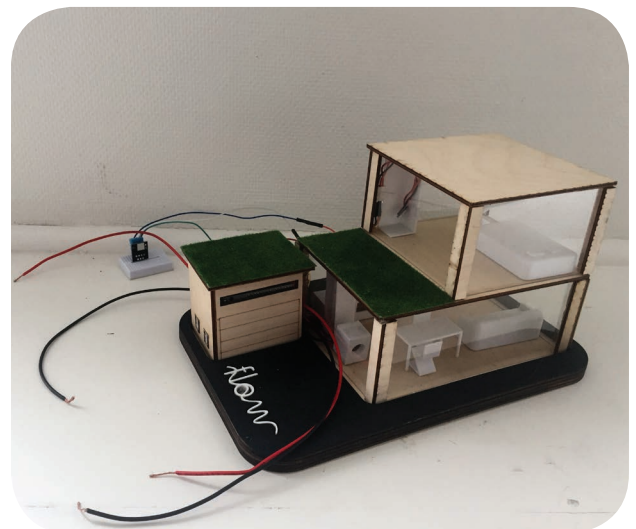

House and Arduino

## Components

### The box includes:

- 1 house;
- 1 base;
- Arduino circuits;
- Furniture for the house.

## Arduino

We have three different Arduino codes, one for each experiment.

The code for the windmill is designed to calculate the voltage produced, according to the amount provided the number of lightning LEDs will change.

The LED lights used for the windmill and their minimum voltage to work are:

- One LED light representing the television that is always on;
- One LED light representing the extractor hood when the voltage is between 0,5V and 0,7V;
- One RGB LED light, representing the fridge when the voltage is between 0,5V and 0,7V;
- One neopixel that represents the oven when the voltage is higher than 1V.

The code for the solar thermal is created to measure the temperature of the water. We used a temperature sensor positioned on the surface of the box that lights a neopixel.

The neopixel colour changes from cold blue to warm red, according to the measured temperature.

When the temperature is:

- Less than 25°: Cold blue;
- Between 25° and 40°: Light blue;
- Between 40° and 50°: Light yellow;
- Higher than 50°: Warm red.

The water turbine code measures the voltage too, but in this case, it is displayed in a different way. There are three different colour LED lights that ignite depending on the amount of voltage obtained:

- No voltage or less than 0,2V: Red light on
- Voltage between 0,2V and 0,5V: Orange light on
- Voltage higher than 0,5V: Green light on

These lights are located outside of the house, in the garage, so if the students connect the three experiments at the same time, they can notice from which experiment is each light.

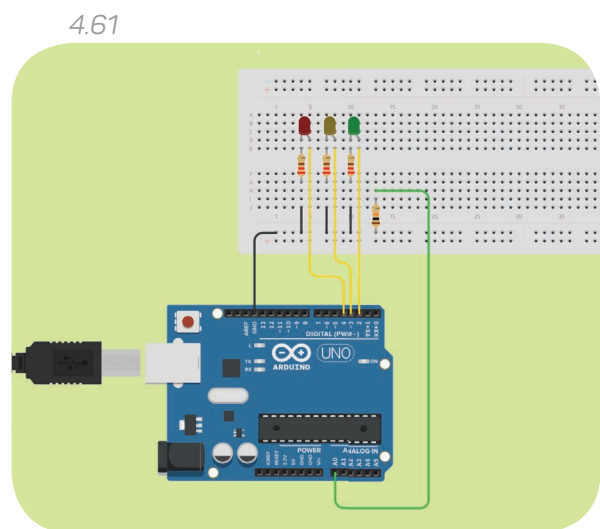

Arduino schematic

*The Arduino code and the schematics can be found as an appendix (Appendix O)*

## 4.8 Testing

In order to accomplish the usability test of the experiments, we went to the Sint Willebrord-Heilige Familie School, where Professor Tinne Van Kogelenberg welcomed us and supervised the workshop. In this sense, the students from 15 to 16 years old of the Belgian secondary schools constitute the target group of our project.

First of all, the workshop consisted of a 50-minutes meeting with eight students from an ASO Science class. In this way, we divided the class into four groups with two members each: a group performed the windmill experiment, the second group completed the hydro turbine, and the solar thermal experiment was executed by the last two groups.

Then, it is explained how each experiment was performed during separate tests:

### Windmill

To begin with, the students received the experiment with all the components of which it consists and the materials necessary to achieve the experiment. The first step is to visualize a short video showing the assembly of the pieces and the different positions that you can adopt. Throughout the experiment, students have a sheet of steps that can be consulted at any time to serve as support and to complete the experiment successfully.

After that, they assembled it and placed the blades of the windmill in different ways, measuring how much voltage was produced by combining the number and position of the blades.

Once the students reached the position of the most efficient blades, they performed the exercises and could visualize how the energy generated by the windmill is transmitted in the model of a house.

Finally, we provided each student with a survey to assess their level of learning, entertainment, and suggestions that may arise for future projects. The feedback from the students was very positive: they had fun and found it both productive and inspiring. However, we noted observations during the workshop in order to take into consideration some changes that could improve the usability test:

- Students prefer to have a video of assembly since it helps them with the visualization of the experiment set up.
- It would be advisable for the students to read the worksheets before starting the experiment.
- Controlling the time would be recommended to complete the entire experiment in 50 minutes.

4.62

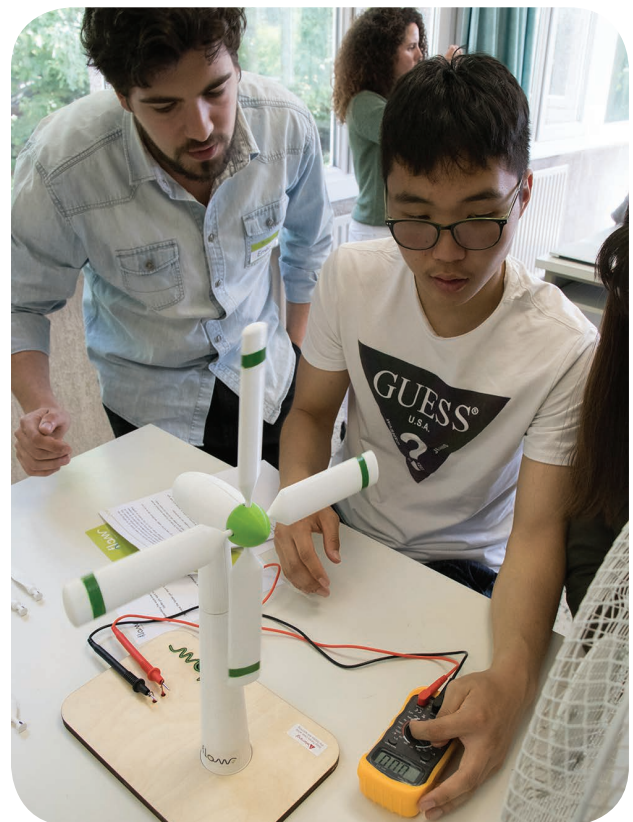

Windmill test

## Solar thermal

The students were introduced to the experiment with the assembly and testing video of the solar thermal, in which they clearly and easily visualized how to successfully complete the experiment. Once the students visualized it, they found all the components of the experiment on the table, as well as the steps sheet and the exercises to be performed.

Then, the students assembled the solar thermal and began the experiment, heating the water in 15 minutes in the solar panel using a lamp and measuring the final temperature of the water.

While they waited 15 minutes for the water to heat, the students had some introductory exercises with questions from everyday life.

Once the time has been completed, they noted the results they obtained and began to perform the exercises, which helped them understand the principles and applications of solar heater.

Both groups made calculations and solved the exercises, although one required more assistance than the other to complete them.

Finally, a survey was provided to each one assessing their opinions, resulting in positive global feedback.

The conclusions that we obtained from the two teams based on the observations made and the teacher's feedback were the following:

- Lack of time to solve the problems during the class.
- A group did not know the equations that are taught in the physics curriculum, which is an obstacle to perform the exercises.

4.63



*Solar thermal test (group 1)*

4.64



*Solar thermal test (group 2)*

## Water turbine

The third experiment that the students of the school realized was the turbine of water, in which it was arranged from the first moment the pieces of which it consisted, the exercises and the sheet of steps.

In the same way as the other experiments, the students were introduced to the world of water and energy through the explanatory video of the experiment. Once it was finished, they assembled each of the pieces with care, at the same time as we explained the relationship between the experiment and the operation of real water turbines. In addition, they had the possibility to change the speed of the water using different nozzles.

Next, they put the experiment to work; measuring the flow rate indicated by the flow meter and collecting the process data in order to complete the exercises about potential and kinetic energy.

Therefore, the students needed help to understand and solve the equations due to the higher level of difficulty with respect to the other experiments. However, the resolution of the exercises was deduced by them, understanding how the experiment worked perfectly.

Both the feedback from the teacher and the students was key in this experiment since it has required the most modifications in the project. Both have resulted in the successful completion of the experiment.

The assembly of the experiment was a bit complicated;

- Lack of time to perform the exercises;
- The complexity of the equations and exercises;
- The measured values were displayed too quickly and the student did not have sufficient time to write them.

4.65



*Water turbine test*

4.66

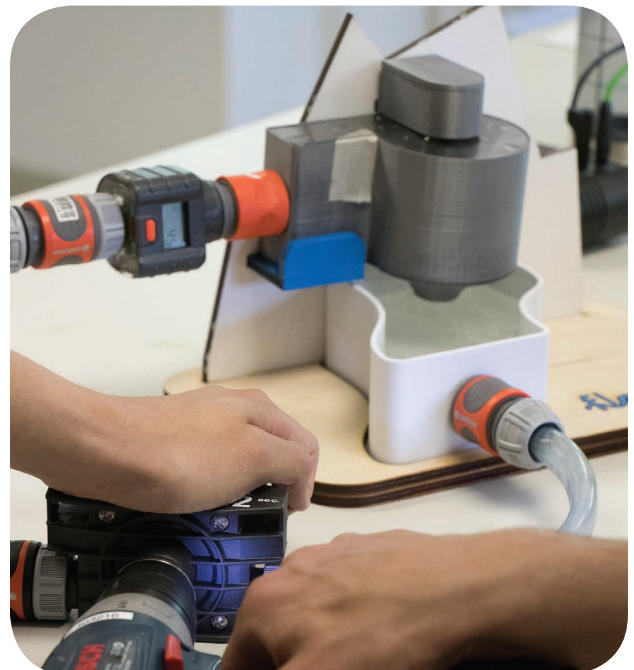

*Testing*

## Review by Dennis Dewit

(Student of the Specifieke Leraren Opleiding UA).

*"When I had entered the class 15 minutes before the lesson started, all the experiments were set up on different desks. Everything was ready for the students to come. Once they were all settled in, Emilio started with a short presentation of the group and the experiments. Soon after, the pairs of students watched their videos on the tablets. These must have been clear to all of them, because they were fast in assembling the parts. The experiments could now really start. I began with observing a pair on the windmill. They worked pretty smoothly to collect data for multiple arrangements, although no graph came out yet. I guess this could be given as a homework assignment. I noticed Emilio explaining them at the end the difference between 3 and 4 blades for real life purposes.*

*I continued walking by the group on the water vortex, but didn't stay there. I only heard they started a little slowly. Most of the time I spent with the two pairs on the solar power experiment. I was afraid the exercise about the water usage for a shower might have been too hard requiring a set of two equations to solve, but one bright guy solved it quickly. The other pair was slower with the calculations, even though I helped them throughout, but they were known to have some trouble understanding physics (and Dutch). Overall I think it fair to conclude that the level of the exercise sheets was okay. The two groups just could finish the experiment twice right in time.*

*I think the students were fond of doing these tests, I only saw happy and enthusiast faces."*

- Written by Dennis Dewit.

4.67

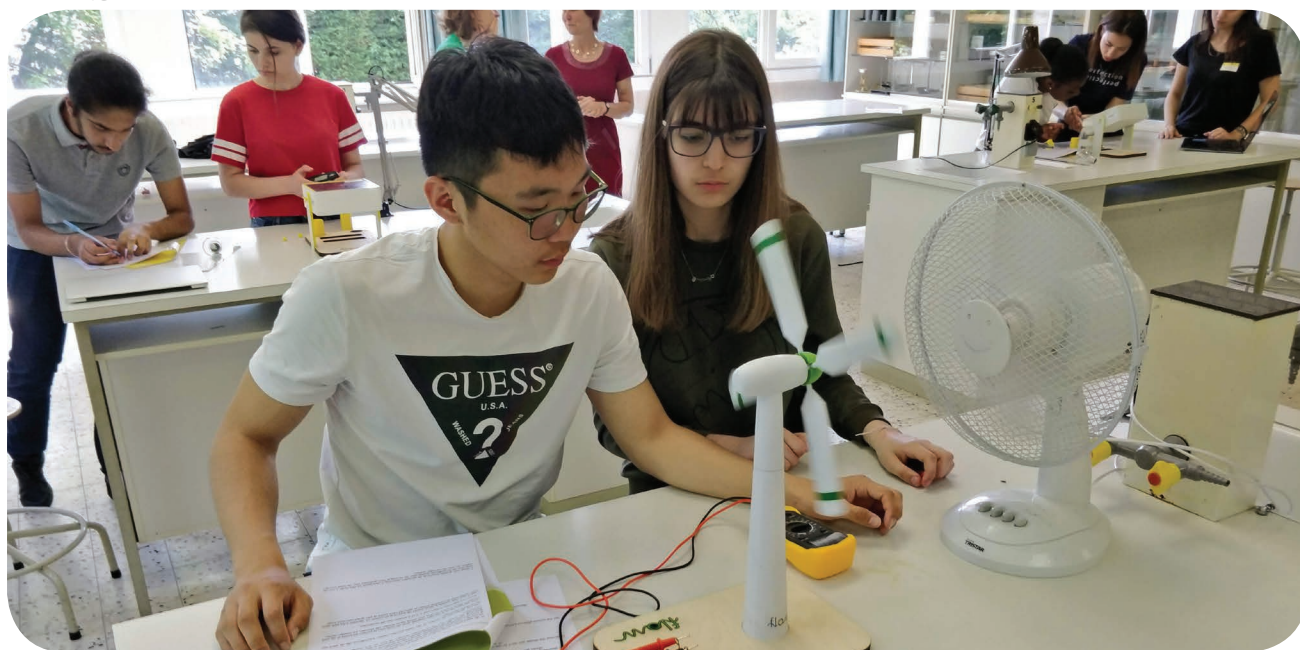

Usability test

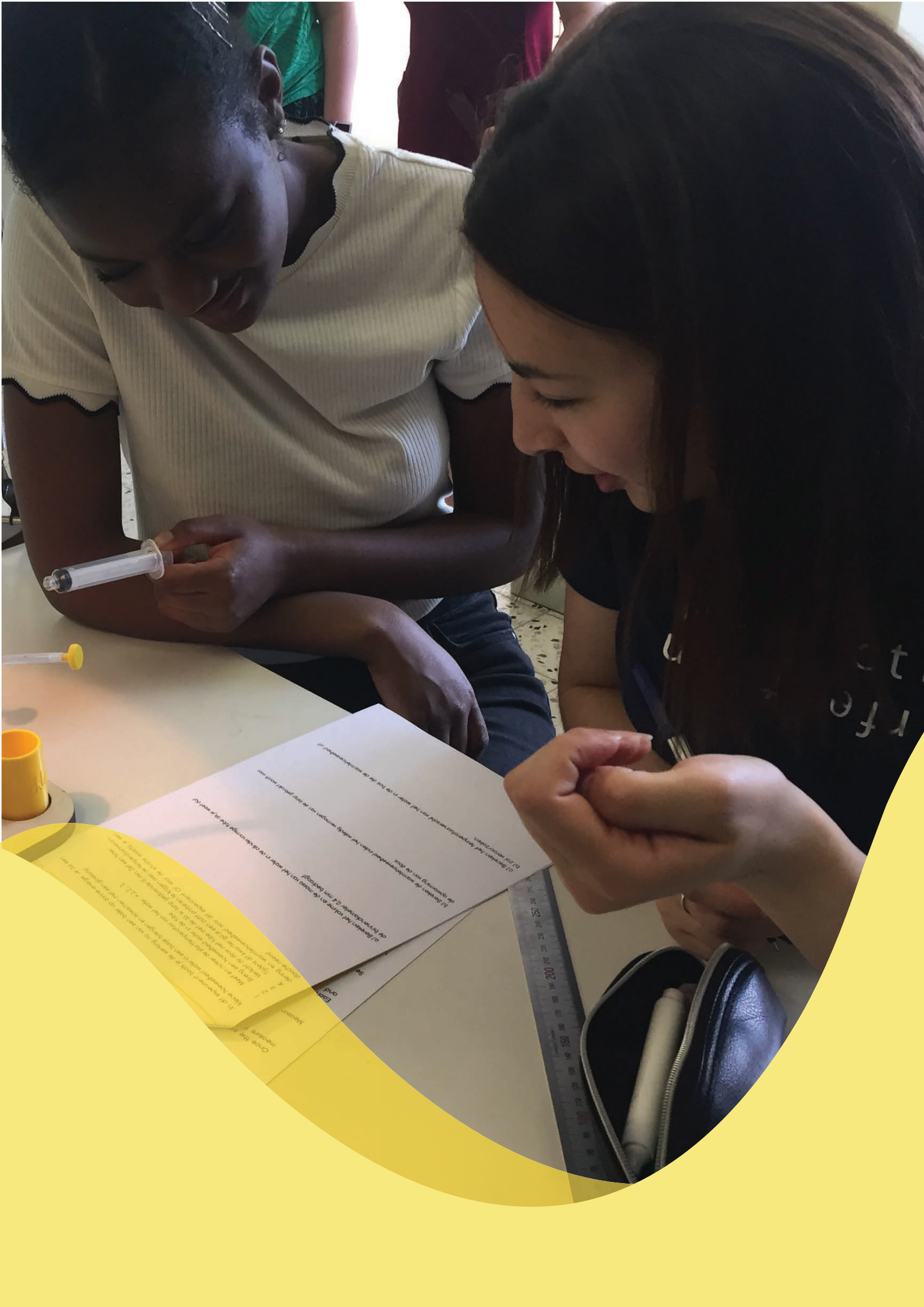

# 5. Experiments' exercises





The purpose of the project is not only to encourage students to study physics, but also to assist them to learn the underlying physical phenomena better. For this reason, we complement the three experiments with the exercises and these questions are designed so that it integrates the experiments into the curriculum. With regards to the context of the exercises, we intend them to be linked to real situations. Thus, the exercises themes are made to represent actions that occur in daily life.

Firstly, in the solar thermal experiment, the principal theory that we aim the pupils to study is the transfer of heat. Therefore, all the questions are related to this topic and require the students to use the formula of heat transfer to solve the exercises. The context of the questions is the use of water in the shower and this is the relevant approach, as the students will have a better understanding of how the heat transfer is applied in household water usage. With the windmill, the crucial components are the blades with a special design to absorb the highest possible amount of wind energy. However, this feature of the blades is complicated and involves aerodynamic theory, which is not listed in the curriculum. Therefore, the students have to make a graph that shows the relation between the angles of the blades and the output voltage extracted from those angles. In the hydropower experiment, it uses the potential and kinetic energy in the water to create electricity which is also be used in the theme of our turbine's exercise. The worksheets require the students to calculate the kinetic and potential energy of water and then apply the conservation of energy theory to calculate the sufficient height to acquire such energy.

## Exercises questions and model answers

### Windmill

#### Question 1

Draw a graph that shows the relation between the output voltage and the blades angles.

#### Answer

The graph below shows the relation between the angles and the output voltage in a 4 blades windmill:

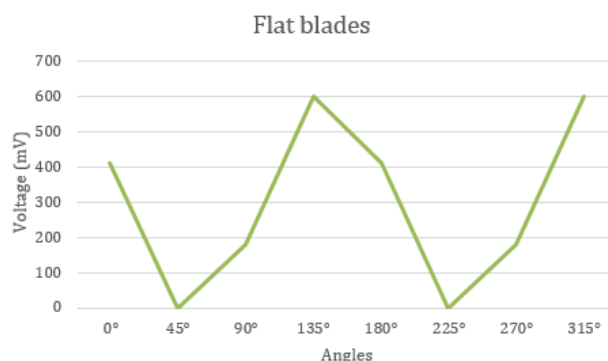
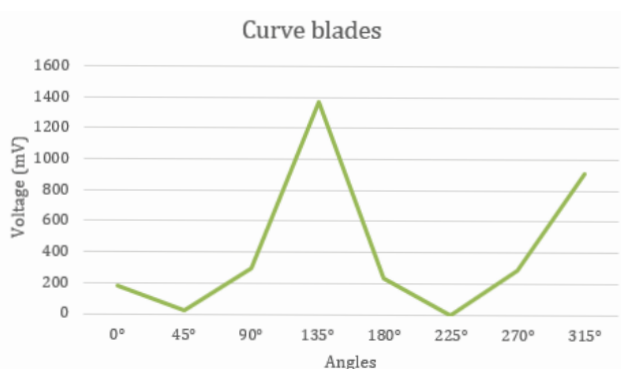

## Question 2

What do you think is the explanation for the different results? Knowing the number of wings, angles and blades shapes are involved. Draw a graph that shows the relation between the output voltage and the blades angles.

### Answer

In the industry, three blades windmill is the most popular and the cost of manufacture of these blades are extremely expensive. Therefore, two, three and four blades are the most ideal to be considered. If we compare the power output of two, three and four blades windmill, the two blades provide the highest power output out of the three. However, it will spin too fast and would cause instability and also create noise. The four blades are expensive and has a greater drag than the three. Therefore, three blades windmill is used widely in energy production.

When it comes to the design of the blade, it is ideal if it absorbs the most of the wind speed. This is achievable by the use of aerodynamic force in the design. This results in a curve blade that creates a difference in pressure between the two sides of the wing, and produces a force that turns it.

Different angles of the blades with respect to the wind direction is also crucial. The ideal position is where the lift force is optimum and the drag is minimum.

## Solar thermal

### Question 1

Shower time is 15 minutes and the temperature that you want to use is 42°C. The flow rate of shower is 8 litres per minute. The temperature of the water results from a mix of cold water and hot water. Knowing that the temperature of cold water is 15°C and hot water is 60°C, calculate how much cold and hot water that you need to mix in order to achieve the desire temperature in mass. In this question, use the calculation of heat transfer:

$Q = m \times c \times \Delta T$  and water density is 997 kg/m<sup>3</sup>.

Abbreviation:

- Q: Heat gained or heat lost (Joules)
- m: Mass (kg)
- c: Heat capacity (J/°C)
- $\Delta T$ : Temperature difference (°C)

### Answer

Duration of shower: 15 minutes

Use of water during this time: 8 l/min

The temperature of shower water: 42°C

The initial temperature of cold water: 15°C

The temperature of warm water: 60°C

Volume of water used for shower:  $15 \times 8 = 120$  litres = 0.12 m<sup>3</sup>

Mass of shower water:  $0.12 \times 997 = 120$  kg

Call  $Q_1$ ,  $Q_2$  is the thermal energy of cold water and warm water respectively. Then  $m_1$  would represent the mass of cold water,  $m_2$  is the mass of warm water. According to the law of energy conservation, the heat gained is equal to the heat lost:  $Q_1 = Q_2$

With  $Q = m \times c \times \Delta T$ , then:

$$m_1 c \Delta T_1 = m_2 c \Delta T_2$$

$$m_1 \times (42 - 15) = m_2 \times (60 - 42)$$

$$\text{But we have: } m_1 + m_2 = 120 \text{ kg}$$

$$(120 - m_2) \times 27 = 18m_2$$

$$\text{Then, } m_2 = 72 \text{ kg } m_1 = 48 \text{ kg}$$

### Question 2

Measure the final temperature of the water after heating inside of the solar panel.

#### Answer

If the distance is 12 cm, then the temperature should be around 37.5°C

### Question 3

After the measurement, calculate the heat gained by the water. There is 10 ml of water inside the tube.

#### Answer

Mass of the water:  $m = 0.01 \text{ kg}$

Heat gained:  $Q = 0.01 \times 4186 \times (40.6 - 22.8) = 745.108 \text{ J}$  (The temperature difference is taken from the measurement by team FLOW)

### Question 4

Calculate the heat energy in Joules that is produced by the bulb during the 15 minutes experiment assuming that all of the power input is converted into heat energy.

#### Answer

$$P_{\text{bulb}} = 36 \text{ W} = 36 \text{ J/s}$$

Then the output of heat energy in 15 minutes is:  $Q = 36 \times 60 \times 15 = 32400 \text{ J}$

### Question 5

Compare the result from question 4 with the heat gain that was calculated in question 3. Is there a difference? If yes, calculate the efficiency of the panel.

#### Answer

The efficiency:  $\frac{\text{Heat gained}}{\text{Heat produced}} \times 100 = \frac{745.108}{32400} \times 100 = 2.3 \%$

### Question 6

Which of the two light bulbs (36W and 53W) would be the best representation of the sun, knowing that when the sun's radiation reaches the Earth surface, it provides a power of  $1000 \text{ W/m}^2$ .

### Answer

The surface area of the panel:  $18 \times 18 = 324 \text{ cm}^2 = 0.0324 \text{ m}^2$

Then the power per square meter of each lamp would be:

- The 36W bulb:  $36/0.0324 = 1111.11 \text{ W/m}^2$
- The 53W bulb:  $53/0.0324 = 1636 \text{ W/m}^2$

So, the 53W bulb is the best representation.

## Vortex turbine

### Question 1

Calculate the kinetic energy of water in the turbine and the height of mountain needed in order to achieve the measured flow rate. The tube's area is  $9.5 \times 10^{-5}$ , water volume is 900 ml, and water density is  $997 \text{ kg/m}^3$ .

In this exercise, you should use conservation of energy. In this case, when the water is on top of the mountain, there is potential energy but the water does not move, so there is no velocity, or kinetic energy. As the water runs down the hill, the potential energy is gradually converted to kinetic energy as the water gains speed. When the fluid reaches the bottom of the mountain and flows to the turbine, the kinetic energy is at its maximum value and there is no potential energy.

Formulas:

- $m = d \times V$
- $Q = A \times v$
- $E_p = m \times g \times h$
- $E_k = 1/2 \times m \times v^2$

Abbreviation:

- m: Mass of the water (kg)
- d: Water density ( $997 \text{ kg/m}^3$ )
- V: Water volume (litre)
- v: Water velocity (m/s)
- Q: Flow rate ( $\text{m}^3/\text{s}$ )
- A: Surface area of the tube ( $\text{m}^2$ )
- $E_p$ : Potential energy (Joules)
- $E_k$ : Kinetic energy (Joules)
- g: Gravitational acceleration ( $9.8 \text{ m/s}^2$ )
- h: Height of the mountain (m)

### Answer

Calculate the mountain height.

The mass of water:  $0.0009 \times 997 = 0.9 \text{ kg}$

The area of the tube:  $9.5 \times 10^{-5} \text{ m}^2$

Assuming the flow rate measured during the experiment is 5 l/min, equals to  $8.33 \times 10^{-5} \text{ m}^3/\text{s}$

With  $Q = A \times v$       Then  $v = 0.88 \text{ m/s}$

The kinetic energy:  $E_k = \frac{1}{2} \times 0.9 \times 0.88^2 = 0.34848 \text{ J}$

According to the energy conservation, potential energy of the water on top of the mountain equals to the kinetic energy of the fluid in the turbine:

$$\begin{aligned} E_p &= E_k \\ m \times g \times h &= 0.34848 \\ h &= 0.04 \text{ m} \end{aligned}$$

### Question 2

Which nozzle gives the highest energy output? Can you explain why?

#### Answer

The nozzle that gives a smaller surface area of the inlet valve will give a higher speed of the water. This is explained by the increase in pressure when the water has to flow into a smaller area, which results in a higher speed.

### Question 3

You can change the flow rate of water by adjusting the power of the pump. How does the flow rate affect the energy output? Can you make a graph showing the relationship?

#### Answer

An increase in flow rate will result in a higher output of energy because a faster flow rate will turn the turbine faster.

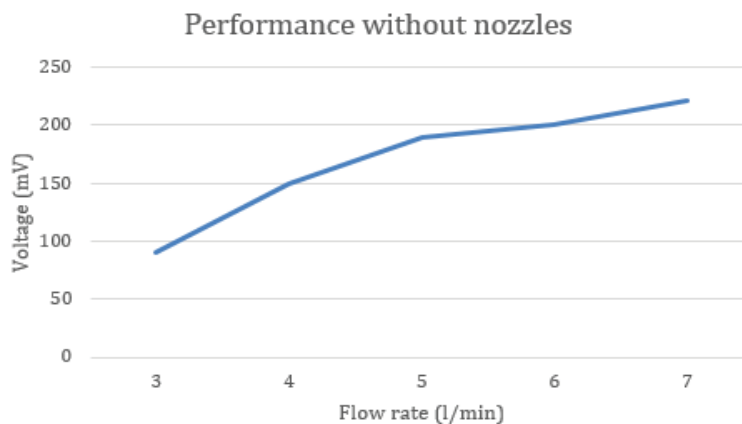



# 6. Conclusions



Every research, brainstorm session, prototype and test brought us this far. We learnt so much in this semester, and each step was really important to help us to continuously enhance the project and to achieve the final result, presented in this report.

It was a challenge prototyping three physics functional experiments integrated into electronic equipment, but due to the subsidy granted by the Flemish government (Department of Education and training) and the workspace and tools, such as a laser cutter, CNC router and 3D printers provided by the University of Antwerp, we were able to build and test several components and models. Each test validated new ideas or showed us that changes were necessary, and since these tests were performed in advance, before finalizing the project completely, time and resources were saved.

With the assistance from these resources, the commitment of the FLOW team, the help of our project supervisor Regan and the usability test in the Sint-Willebrord Heilige Familie school, we reached our aim of developing practical experiments to implement renewable energy into the physics curriculum.

Even though it is difficult to really measure the degree of learning that the students took from this workshop, we noticed during the tests and from the feedback in the surveys that the students are more interested, engaged and pay more attention when they are participating and executing tasks. When they actively participate, learning becomes more enjoyable and easier, primarily for those who are demotivated.

All subjects can be taught in interactive ways, we just need to find teaching resources other than blackboards and books, and encourage new ideas. Projects such as this are great initiatives, they help to improve education and can be used as examples.

# Recommendations

Taking into account all the developing processes, the tests and the results achieved during this semester, there are some suggestions for future updates of this project.

The duration of the workshop should be shortened. The class hour is only 50 minutes, and there is not sufficient time to perform the experiments, to test the results in the house and to finish all the exercises. A good solution would be if the students could take notes of the results during the workshop and then finish the exercises as homework.

The video was a suggestion from the previous Energy Wizards teams and it worked. The students watched it before starting the experiments and they did not have problems to perform them, they didn't even check the steps sheet we provided. Nevertheless, there are still some improvements that could be considered in the videos. Before starting the experiments, the students should read all the questions in the worksheet, to know exactly what information they will need to fill in the exercises. This should be explained in the video.

Furthermore, at the end of the videos, it is not clear that after finishing the experiments the students should be connected to the house. If the students just conduct some of the exercises in the classroom and the others at home, they will have more time during the workshop to see the practical application of the energy that they produced. For this reason, we suggest editing the videos, to show and to make the workshop time division clearer and also to make the comprehension of how to attach the experiments to the house easier.

Creating an online platform to the FLOW brand, such as a website or an application, is an idea that emerged during the project, but we did not have time to execute. These tools would help to advertise the product, provide extra educational materials and maintain the topic's information always updated. The website could allow personal access for the students and teachers, and mainly, they could make learning even more interactive and fun.





# Personal Reflection



## Duy

This is a personal reflection on my contribution to team Flow. The page describes my major work as a member of the team and the experience that I achieved after the project.

After five months, I gained a significant amount of experience and knowledge, both in renewable energy topics and group collaboration. In the

beginning, the “Energy wizards” group had a discussion on the roles of each member. Considering my background as an environmental engineer, I was assigned to be the product engineer. My objectives included researching information on the three topics of renewable energy that we would use in our project: Hydropower, solar water heater, and windmill. After the research period, I had to conclude and explain the findings to other teammates of team Flow. Then, the group started the brainstorming sessions, in which we discussed the ideas that could improve the previous experiments from EON and H2OME. Personally, I suggested replacing some of the components of the solar heater, such as to switch the Styrofoam to Cellulose, which was more environmentally friendly, and to use an incandescent light bulb as it provided more heat. I did not suggest any ideas on the windmill, however, since I was responsible for the development of a new hydropower experiment, I had the freedom to choose a new type of water turbine, which was a gravitational vortex power plant. The plan was to scale a real vortex turbine to a reasonable dimension for the experiment kit and I proposed to use a pump to make the water experiment a closed-loop system. Additionally, I was responsible for calculating the sufficient dimension of the turbine to achieve the highest possible efficiency and I also took part in the manufacturing process of the water vortex turbine. Then, after all the three experiments were completed, I wrote the exercise sheets and model answers that integrated these experiment’s physics principles to the student’s curriculum as well as conducted tests on the kit to have solid data for completing the exercises answers. In these final days of our project, I have been supporting Henar in fabricating the experiments containers. The production is still in process and we have encountered a considerable amount of problems, but thanks to careful discussions between us and Regan, along with our patience, we believe that we can finish it before the presentation. In terms of the team report, the part of my writing was not different from which was in the mid-term report, that was the topic research and vortex turbine. Besides that, the exercise sheets and model answers were also included in the final report.

Teamwork was a bit confusing for me in the first couple of weeks, but I managed to blend in and contribute my best to the project. Other teammates also did a wonderful job with respect to their work such as brandings, designing, and prototyping. Through group work, I also became aware of my position as well as other members specialization. Emilio was a great leader that guided us towards our targets and he also greatly assisted me in building the vortex turbine. Gabriella, as usual, was an excellent graphic designer that beautifully made our report and brandings. Paula was a hardworking member with creative ideas, and she also contributed to the manufacture of the solar thermal as well as the Arduino. Henar, who was also one of those that helped me to complete the turbine, was a careful designer as she was responsible for designing our experiments boxes and she also contributed to the solar thermal experiment.

In my opinion, our work process was done in very limited time and yet we still achieved the desired goals. Our team are quite satisfied with the results, however, there is always room for improvement and we learned that time management is always a crucial factor in order to fulfil the requirements. Therefore, after the mid-term presentation, we hurried to the prototyping process and rescheduled the Gantt chart. Personally, I also advanced in my fabrication design of the hydropower experiment by continuously testing and consulting with our supervisor as well as assisted others in their work.

The project taught me such vital lessons that changed my point of view. By working with other product developers, I have learned how to use a design program on a basic level, be creative and not to always follow theory and team communication as well as relationships are key factors. Interestingly, since we spent a substantial amount of time in the workshop for prototyping, which was a new experience for me because I only worked in chemistry and biology laboratory in my home university, I gained a large number of skills in prototyping a product such as using different types of hand tools, handling and manufacturing wood material as well as 3D-printed components. Most importantly, I and team Flow learned how to distribute the work efficiently and schedule the time in a better, more logical way.

In conclusion, I would mark myself a 1.8 on the personal improvement and a 2 on team Flow for the effort and improvement that we committed and accomplished.



## Emilio

For four months now, I have been the group leader of the Energy Wizard group: FLOW, which is a part of the European Project Semester (EPS). After finishing our final report, it is time for a reflection of the past months of this project. In this reflection, I discuss my contributions to the group, the project and what I gained from this EPS-experience.

Working in group can be challenging, especially working with an international group of multidisciplinary students. I have had first-hand experience conducting international teamwork during my time as a merchant marine student. However, designing a new product with such a team was a new experience to me.

Initially, the start was the hardest part, especially managing the start of three different experiments simultaneously. The Gantt chart we set up during the project management classes really helped structuring our schedule and setting realistic goals. Although, the project related courses were interesting, they had a negative effect on our time management.

In order to gain some time, we distributed the project work into smaller components and I assigned each member their own tasks. Then we would pick a date and show each other the finished tasks and discuss the results and the hypothetical problems. This method worked well for the smaller defined tasks, however, it did not work for the larger design-related tasks. When a problem occurred, some of the team members waited until the meeting to discuss their problems with the other team members and because of this, the design process decelerated. As a result, I learned to divide the tasks in smaller sub-tasks and tried to provide the members that needed it with these more defined tasks. Clear communication and a close follow-up improved the daily work.

At the start of the prototyping phase, I noticed that some of my team members were used to a very theoretical approach instead of the practical one that we use within PO (product development at the University of Antwerp). This affected the work dynamic and decelerated the process. However, they were eager to learn and assisted me when possible. As a result, we achieved our goal and executed a marvellous usability-test.

Besides team leader, my task was to realise the windmill experiment, provide all sketches and create all the CAD-files (Computer Aided Design) needed for 3D-printing and rendering. I underestimated the amount of work of the iterating prototyping phase. However, short nights and coffee were the solution to finish all my tasks. As a team leader, it can be hard to preserve a clear overview of the project and everybody's work while managing my own contributions to the project, since focusing on one aspect of the project is not my strong suit. However, I feel that my skills have progressed and with the motivated team behind me we achieved our goals.

In summary, despite some managing and communication issues, I am very pleased with the results we achieved, and I am proud that I had the chance to be the leader of this hard-working group.



## Gabriela

This personal reflection has the aim to describe my experience in the European Project Semester, primarily my apprenticeships and my contributions to the Energy Wizards team.

I chose the European Project Semester because I intended to have the opportunity to work with people from different fields of study, from different places all over the world, and to practice my English and knowledge in Design. Now that we are in the middle of the semester, I can say that I am very happy with my decision to take part in this programme, my expectations were exceeded and I have learned so much from the project and the teamwork. During the last months, each phase was really important to bring us to this point.

We had several classes to help in the project development. Courses focused on teamwork, such as Teambuilding and Intercultural communication, which made us to know ourselves and each other better, and also courses that presented us with some useful tools, such as Project Management, which helped us to structure a schedule and deadlines for each task using the Gant Chart. Not all the courses we had were useful to our project, some weeks we had a timetable full of classes and we felt that some tasks were very similar to other things we had already performed, and they would provide no added value, just delayed the schedule we had planned. Despite that, the team tried to remain focused on the main goal without neglecting the other obligations, and as a result of the organization and proactivity of the group, we have succeeded in reconciling all the assignments and perform them in a satisfactory way.

Since we are an international and interdisciplinary team, we have different ways and time to perform tasks, and each of us have more knowledge and affinity for some fields. These differences could have become a problem for the group, but due to the group dynamics we had in the Teambuilding course, and once teamwork started, we began to understand each other's characteristics and personalities as well as the strengths and weaknesses in the group, in order to obtain the best from all the members. In order to maintain the alignment and to track the project development, we tried to meet daily during the week and

use online project management tools; in this way everybody could follow the progress of the tasks, to know their responsibilities and the deadlines, to help if necessary, to ensure the high quality of the deliveries, and also so that no one is overwhelmed.

I think that my contributions during this semester were to maintain the team focused on the goals, to help in the organisation and the division of tasks, and also to monitor the schedule to avoid delays. In my personal development, I intended to leave my comfort zone, which is product development, to face the challenge of helping in the development of the corporate identity, the brand and all the graphic materials of the project, and I can say I am pleased with the results and the apprenticeships.

I know that I did my best. I can say that I participated in every phase of the project and helped anytime I was required. Me and Paula did the prototype of the solar thermal, I designed all the graphic materials for the experiments, me and Henar recorded the video, and I edited it. I organized all the report in the final layout, and I also helped in other general tasks, such as prototyping the other experiments, and taking pictures of all of the project development process.

Now that the project is done, I can say that I am very pleased with the results. The team worked very well together, we shared knowledge with each other and improved our communications skills. I am glad with the team effort and I know that these successful results are due to the commitment of each FLOW member.

If the group could go back to the beginning of the project, I would suggest to better divide the tasks among the team, because several times during this semester some members were more overwhelmed than others.

In conclusion, the EPS programme was a very rewarding experience. Everything I learned, the friendships I made, and the moments we lived, these will be memories that I will remember forever, with great joy.



## Henar

The objective of this reflection is to highlight my contribution both to the team and on an individual level in the project.

Firstly, the different courses that have been taught during the development of the project have helped me to learn how to manage different

tools and new methods in all the phases of the project, obtaining satisfactory results according to the stipulated objectives. As a result, being part of a multidisciplinary and international team has allowed me to visualize the project from different points of view, at the same time that I have evolved both personally and professionally. All this has been accompanied by language learning at an academic level and its use during the presentations of the project, an aspect that I consider of special relevance in a globalized world in which the communication of ideas prevails and, therefore, the correct use of the language and its transmission is essential.

Regarding personal contributions during the development and execution of the project, I have accomplished various tasks such as testing, brainstorming, development of new ideas and modelling of prototypes. Particularly, I have performed the ideation, design, modelling, and manufacturing of all parts of the packaging, which integrates an individual box for each experiment and the house, as well as a global container that integrates all the packages. In the same way, I have participated in the design and manufacturing of the solar thermal experiment and the house throughout the process, in addition to the contribution of new ideas in the windmill experiment.

In order to execute the workshop with the students, I collaborated in the making of the introduction videos to each experiment along with the development and design of the exercises and steps. Similarly, I consider that my role in the project has been a key part in the definition of the problem and ideation of models and prototypes.

During the EPS, I have developed various professional skills among which are the management of all aspects of the project and the integration of each task during the phases of the design process. All this, joins the resources that have been put at our disposal to improve our communication skills in the project, which I consider of great value, since they have helped me to establish interpersonal links with my team and, in this way, has created a



relaxed atmosphere in which ideas flow to make way for an excellent project. Besides, I have managed the work process of the project respecting the timetable assigned to each task and, consequently, I believe that the planned objectives have been achieved very satisfactorily.

Comparing my specialization with those of my team, I observed that I have a wide knowledge about the culture of the project, being able to develop my capacity to adapt the creativity, the methodological tools and the knowledge acquired during my studies to solve problems of a different nature, related to product development, commercial aspects, marketing, and so on. Also, I know first-hand the development of the writing and interpretation of technical documentation, applying the rules, regulations, and specifications of the products.

Regarding the results I have achieved, I am very satisfied since all the objectives of the project have been accomplished. Naturally, it has been a long way in which I have done my best in order to obtain my maximum performance and excellent results. With a view to the final report, we have taken numerous actions to improve our results and reach our aim. On the one hand, we elaborated a new Gantt Chart to reorganize the project and, on the other hand, we began to work individually since the most relevant decisions were already taken as a team.

With reference to my contribution to the team, I have improved the performance of the project in different areas, such as the contribution of new solutions, creation of multimedia content, 3D modelling, simulations and manufacturing. From here we could say that each team, as each person, is different: You have to know how to benefit from the strengths of the group and how to diminish the weaknesses. In my case, the team consisted of two industrial design engineers, two product developers, and one environmental engineer. Due to this fact, I have discovered that the role in which I find myself most comfortable with is that of a researcher, relating engineering with science and design.

Considering a possible improvement both at team and at individual level, I would highlight a better understanding and synchronization in the execution of the project so as to reach the proposed objectives.

In conclusion, I feel that I have evolved as an industrial design engineer due to the different EPS courses, which have served as tools during the development of the project. In addition, being part of a team that includes various disciplines and international backgrounds has allowed me to learn how to work as a team, visualizing and solving problems from different perspectives.



## Paula

This personal reflection describes my experience and my contributions as a member of the Energy Wizards group, which is part of the European Project Semester (EPS) program.

This experience has helped me to apply the

knowledge acquired throughout my studies and to develop skills that I was lacking when working on group projects. Moreover, working with people with different backgrounds has given me the opportunity to learn different approaches to problem solving.

I contributed to the project work as much as possible, after the midterm presentations we started the prototyping process, and together with Gabi we did the solar thermal models, I acquired a lot of knowledge during the prototyping process since I have never worked before with 3D printers and laser cut machines. Another of my contributions to the project was the model of the house and the electronics with Arduino, even though I got a considerable amount of help from Ellen, the electronic part was really challenging for me since I have never programmed with this language before, it required a large amount of time, the mistakes were difficult to correct and welding all the components together was not easy either although, it was truly rewarding when it was finished.

I believe that we managed in a good way the project work process, every team member had equal authority on the decision-making, all the ideas were listened and taken into consideration and we always tried to reach a consensus.

I am really happy with the results achieved by the team and my own personal work. We managed to finish all three experiments with a house and a large number of graphic materials; even though we had some time problems before the midterm, we could control it to achieve the best result possible. Furthermore I am pleased with the workshop we conducted for the students as all three experiments worked and it engaged the students.

After the midterm, we made some changes in order to improve our final report and the time problems. Firstly, we designed a new Gantt chart for the second part of the project and we created teams for each experiment and just focus on finishing them. For our English problems decided to finish the report before the draft, so we could have a first correction and a chance to improve our texts.

My general opinion about the project is positive, I really enjoyed working with the Flow team, we had a good workflow, sometimes communication problems, but the interaction between all the members of the group is really enjoyable. I believe that the Energy Wizards is a successful project.



WORKSHOP TOOLKIT

ENERGY WIZARDS

Research

TEACHERS  
- old projects  
- STEM  
- How it works

- SCIENCE  
KIDS  
- KNOWLEDGE?  
- GAMES?

ANOTHER

BIC  
WATERBORO  
MARKERS  
FINE LINE  
CHALKBOARD  
GREEN

BIC  
WATERBORO  
MARKERS  
FINE LINE  
CHALKBOARD  
BLUE

COFFEE  
chocolate  
ie  
colate



# Appendices



# Table of contents

---



APPENDIX A: Related courses  
APPENDIX B: Project plan  
APPENDIX C: Gantt chart  
APPENDIX D: Extended market research  
APPENDIX E: Extended topic research  
APPENDIX F: Extended previous years' research  
APPENDIX G: Technopolis  
APPENDIX H: Brand book  
APPENDIX I: Graphical materials  
APPENDIX J: Video storyboard  
APPENDIX K: Product presentation  
APPENDIX L: Technical drawings  
APPENDIX M: Arduino code and schematics  
APPENDIX N: Business canvas  
APPENDIX O: Moodboards  
APPENDIX P: List of references



## APPENDIX A Related courses

### Team building

When beginning the preparation of the EPS, the subject "Teambuilding" was executed during the first two days, with the purpose of knowing the members of each team and creating a relaxed, productive and friendly environment, in which the ideas flow and students can express their different opinions.

For this, our teacher Sarah Rohaert organized a series of activities to determine our role in each team and establish interpersonal ties that will lead to achieving the project's objectives. One of these exercises was to perform the Belbin Test, which shows how people behave in the workplace and which roles are the most appropriate to assume in a team environment, in order to help the best of each group. In this way, this subject becomes the first step to achieve a successful and professional project.

### Business model canvas

The business model canvas class was lectured by Francis Dams. In this class we learned how to build a Business Model Canvas on the Osterwalder format in order to help achieve our project and look at it with a broader more economical view. The class added an extra value to the EPS programme by offering us a more business minded view in the design process, it was a new experience for every one of the team that will help us see opportunities in our future career.

### Intercultural communication

During the first week, the Professor Christine Boudine from the University of Kiel helped us to know a little bit more about each other cultures and traditions. It allowed us to understand that learning about one another is very important, primarily when we are working in groups since it helps to prevent judgments and labels, makes the teamwork easier and the relationships more pleasant.

### Project management

Ernst-Jan Goedvolk from the University of Applied Sciences in Enschede taught us how to plan and manage a project. For this class we had to deliver a project plan, which we had to define the project specifications and structure. This was primarily useful as we were able to overview all the work we had to accomplish and plan the deadlines for each task to achieve our goals.

### English: academic writing

Andy Vermeulen, who is our English teacher, is very devoted and enthusiastic. He taught us about the structure of a report, gave us tips on formal academic writing and scientific paper, and corrects our grammar. Most of the time in class, we do exercises on English grammar such as phrasing, paragraph structure, passive and active voicing, etc. After we finish the exercise, Andy always corrects it meticulously and also shows his point of view on our different answers. In conclusion, the class is vital to our report writing for the project.

## English: giving presentations

In order to create the presentations of our project in a clear, dynamic and effective way, Zoë Teuwen taught us English classes. More specifically, the teacher shows us different presentation skills, as well as the structure that we must follow, using appropriate language and some advice when creating illustrations, posters and answering questions. Undoubtedly, it is a class that helps in the oral expression of each member and collectively, so as to give the best of ourselves.

## Crossmedia communication

Professor KP Ludwig John, a lecturer from Augsburg University of Applied Science, provided a two-day Lean UX workshop. In the beginning we created personas based on typical users of our product to refine the understanding of the target group, then we wrote the hypotheses for each persona, what we required for them and the outcomes or the problems it would help to solve. In the end, we developed and tested a Minimum Viable Product (MVP) to validate one of the hypotheses. We learnt that prototyping and testing are important in every phase of the project, as simple as the idea may be, it helps to understand if the product is in the right direction, thus to prevent future problems.

## Dutch

The first half of the semester, Els Le Page has taught us Dutch classes, which have been fun and entertaining in every way. These classes consist of a basic course of the language in which we have learnt how to present ourselves, express and ask about

certain information, several aspects of daily life such as shopping, asking about a certain place, modes of transport, etc.

Therefore, we have learnt to talk about the basic concepts of our project, as well as our objectives and solutions.

In brief, we consider that this course is necessary and useful to start this new stage in Antwerp and be able to participate in the day to day, culture and Belgian tradition, while enjoying in the classes tasting typical products of the region (chocolate, waffles, drinks, etc.) and we learn together about the different cultures of all EPS members.

## Portfolio

The portfolio class is taught only to the Belgian delegation of the EPS-team. In this class they discuss and develop a website to capture the EPS-experience. The website will be used as promotion and guideline for future EPS-students.

## Portfolio

In the last months of the EPS, we have received a group of business students from the United States, with whom we have shared the Business class in the EU. This class, taught by Professor Sascha Albers, has helped us to understand the political and economic factors that led to the founding of the European Union, analyse the tensions and key potentials that underlie the European Union, as well as identify and evaluate the origin of political, cultural and economic diversity in the European Union.

In conclusion, this subject has brought us closer to the world of business from different points of view with highly valuable knowledge from a business point of view.



# APPENDIX B

## Project plan

### 1. Background information

The project described in this plan is to design a STEM kit with three completed, working experiments for physics classes according to the curriculum of the Flemish school system along with a packaging to move it around and a manual.

The project has been running for two years from now, where the windmill and the solar heater experiment were done, both experiments are good so we are able to work from that previous work and learn from their successes and challenges.

The Energy Wizards project team is formed by Duy Nguyen, Emilio De Jonghe, Gabriela Pereira, Henar Martínez and Paula Navarro.

The University of Antwerp provides project supervision by the product development department, also the toolkit will be design and prototyped at campus Mutsaard. The key stakeholders we identified include, Regan Watts, the project's supervisor from the faculty of design sciences, The school Sint Willebrord Heilige Familie and it's physics teacher Tinne Van Kogelenberg. Other interested parties are other physic teachers and the kids from schools.

The project is sponsored and funded by the Flemish government that provides us a budget.

The resources available to the project team include, the previous experiments done in the last two years, the project supervisor Reagan Watts, access to interview the physics teacher from the school. Prototyping and manufacturing materials, equipment (3D printers, laser cutting) the five students of the team with different international backgrounds.

The project plan will be approved by Reagan Watts and reviewed with a checklist.

## 2. Project results

The project's general aim is to implement renewable energy into the physics curriculum (of the Flemish school system) by the use of three practical experiments. Our goal is to make children excited about science and place their theoretical knowledge into a real-life context.

The end result will be a complete kit of three experiments and a teaching toolkit, manufactured using laser cutters and 3D printers. Once we had all three working prototypes we will test them at the school.

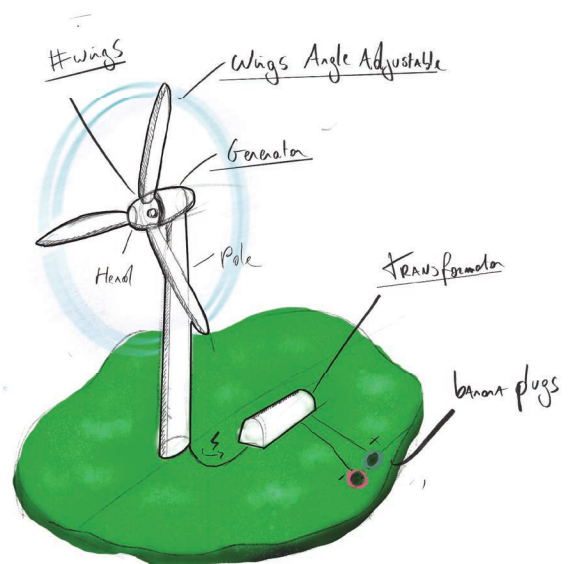
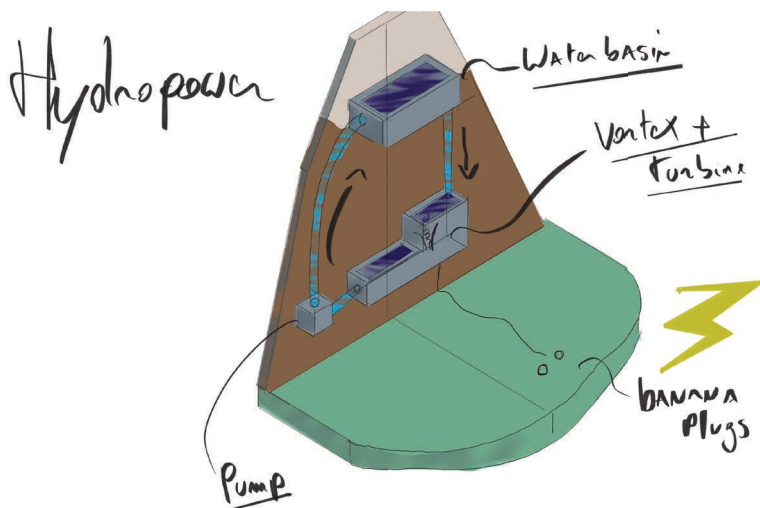
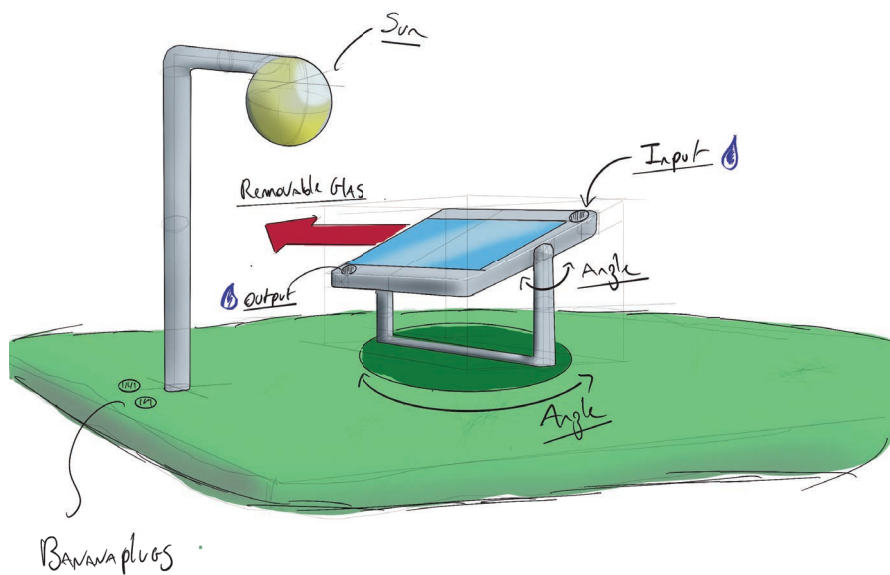

### 3. Project activities

On the next figure you can see our Work Breakdown Structure (WBS) which consists in six main activities divided into different sub activities.

We will do the same activities for the three projects, but with the windmill and the solar heater we have information from the previous years so the time dedication will be minor as most of the research is already done.

We also decided to fix a deadline to finish this two experiments before the Easter break, so then we can focus on the water turbine prototype. For this third experiment t we do not have any previous information so the time spent in research and preparation will be longer, but our objective is to decide how and what do we want to do with this experiment as soon as possible, as the time is an important factor since 3D printing takes a lot of time and we will have to test it with the students and do the necessary adjustments if required.

We made a Gantt chart for the whole semester that includes all the activities of the WBS.

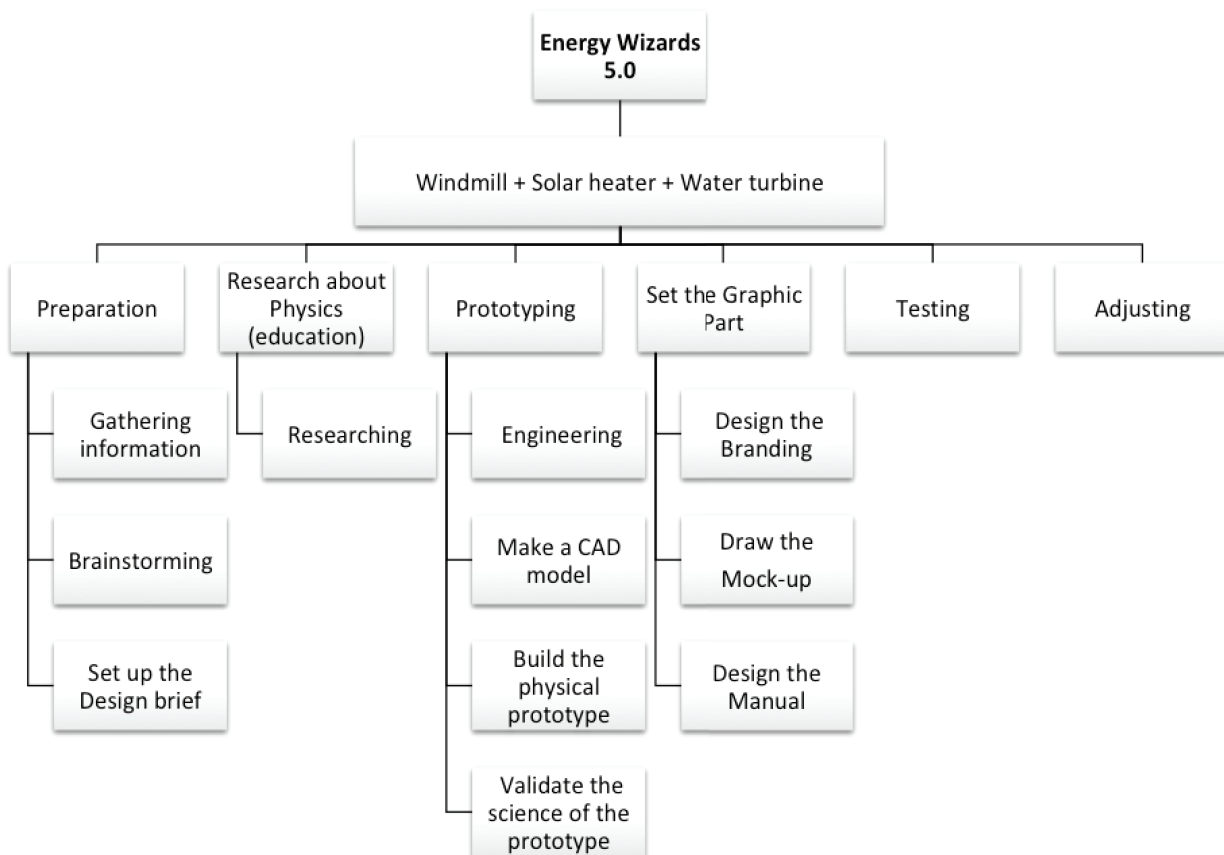

#### 4. Project limits

The project started on 25/02/2019 and all work will be done by 10/06/2019. The result of the Energy wizards will provide the needs of more interesting, interactive science for secondary school students.

Hence, this project covers the renewable energy collector models, any involved design of branding, models, experiments, any research that support the making of the models and educational approach. Clearly, this work is only for education purpose and does not include any business aspects like making profit.

Also, the group will not participate in the class itself to showcase the kit, but it is the teacher who will use it as a tool and directly teach the students. During this design time, the group is allowed to use the school facilities for research, meeting place, making 3D-printed models and any use of money on the project will be returned from the school budget of 3000 euros.

In the end, the success of the project will be evaluated based on these criteria:

- The satisfaction and feedback of the teachers
- The interest of the students after the experiments
- Quality of the products

## 5. Intermediate products

See section three on page 3.

## 6. Quality control

It is desired that the prototype acquires the highest possible quality according to the use that is going to be given: students should be able to manipulate the prototype without any risk and interact with the different components available.

For this, the different materials that will be used must have a good finish, getting the final prototype to be consistent and solid. Special care will be taken in the wiring and critical parts of the prototype to ensure maximum safety.

Besides, we will investigate all the possible scenarios that can go wrong to solve them in due time and in order to not have later problems in their use.

We will verify the safety of the materials provided, making sure nothing is broken, check the wiring, water, and electricity.

The different controls that provide the final quality of the product will be carried out in several stages of the process: at the end of each project (windmill, solar heater and water turbine) and at the end of the final prototype with the three projects.

In these controls, responsible members for each project are involved, in addition to our supervisor, Regan. These consist of visual and tactile control, in which the prototype is manipulated and we can interact according to its future use.

In addition, we will measure the final quality with surveys to students and teachers about their final vision of the project, at the same time as we can have some feedback, comments, and advice for the coming years.

## 7. Project Organization

As we can see in the WBS the project has been divided into six parts: preparation, research about physics in the educational field, prototyping, set the graphics part, testing and adjusting. From here, different tasks are subdivided that have to be done in due time.

In this way, Emilio will be the person in charge of the three projects (windmill, solar heater and water turbine), due to his knowledge of Dutch and his capacity of organization and leadership.

We chose Paula as responsible for the windmill since thanks to her skills in Industrial Design she will be able to provide the required design for this product.

Duy is the expert in environmental engineering, so he will be responsible for the water turbine and the science behind the prototype.

Henar will be responsible for solar heater, managing to design an attractive and catchy project for students.

Gabriela will take care of the branding part since she is the most talented in graphic design.

In this way, the five members of the team will work in all the parts, but those responsible for each project will be in charge of achieving it successfully in the established times and with the required quality.

For his part, Emilio will review each of the projects and will have control over the prototype as a whole.

In this way, the different tasks will be adapted according to the strengths and knowledge of each member of the team.

The time dedicated to the project is every day of the week, either in the morning or in the afternoon. This work is usually carried out in the class that has been provided for the EPS, in a relaxed atmosphere in which ideas and creativity flow better.

In addition, we have a meeting with our supervisor, Regan, every Thursday at 2:00 p.m. This meeting usually lasts 1h30-2h, and the professor is kept informed about the weekly progress of the project.

For its part, the EPS coordinator of the project will be informed when we reach the different goals of the project.

Moreover, we are using different applications that help us to organise the project such as Google Drive for the storage of sketches, sketches, 3D models, research, etc., in which our supervisor is to be updated of all the progress of the project and Trello to divide all the tasks.

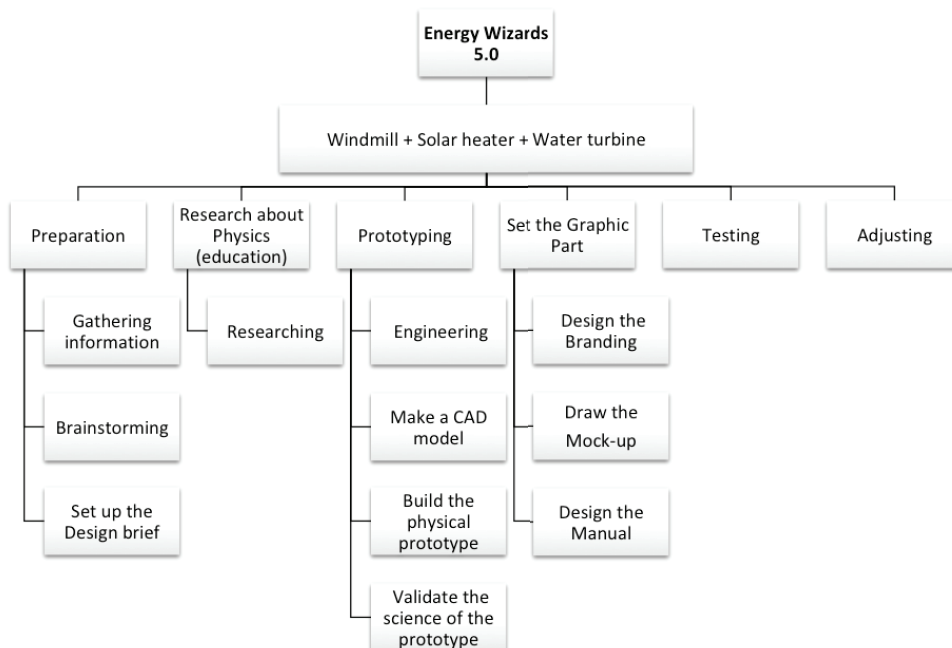

WBS - Energy wizards

## 8. Scheduling

In order to carry out the tasks of our project successfully, the Gantt Chart has been drawn up, in such a way that the activities to be carried out and the time that each task will take is clearly displayed.

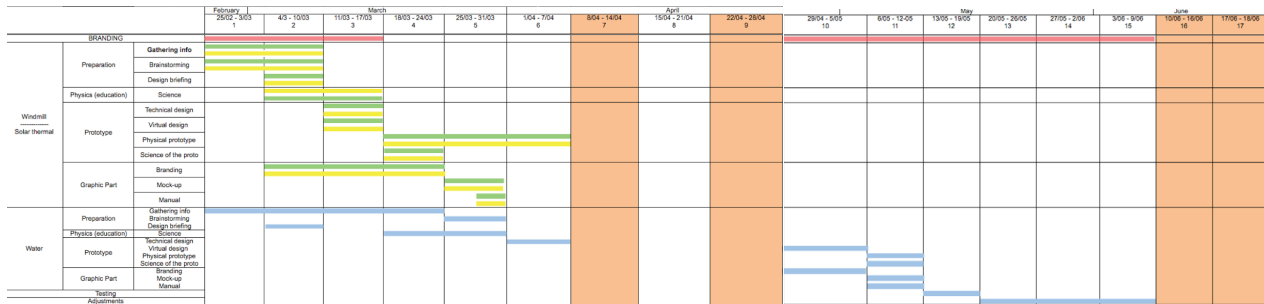

Furthermore, we have redesigned the STEM-inspired workshops, developed during EPS in the last 2 years, as we can see below.

	Duy	Emilio	Gabriela	Henar	Paula	Regan	Sarah
<b>Gathering info, brainstorming</b>	R	R	R	A	R	C	I
<b>Branding</b>	R	R	A	R	R	C	I
<b>Windmill</b>	R	R	R	R	A	C	I
<b>Solar thermal</b>	R	R	R	A	R	C	I
<b>Water turbine</b>	A	R	R	R	R	C	I
<b>Oversee project</b>	R	A	R	R	R	C	I
<b>Science</b>	A	R	R	R	R	C	I
<b>Budget</b>	R	A	R	R	R	C	I
<b>Making notes, agenda</b>	R	R	A	R	R	C	I
<b>Standard formats</b>	R	R	R	R	A	C	I

**R = Responsible, A = Accountable, C = Consulted, I = Informed**

On the one hand, our meetings are flexible so that all members feel comfortable doing their work, in which creativity and productivity fluids.

On the other hand, we wanted to set a time for unforeseen circumstances, since this way you can reach the end of the project successfully, at the same time that we achieve our personal objectives and goals.

## 10. Risk Analysis

BOW-TIE analysis:

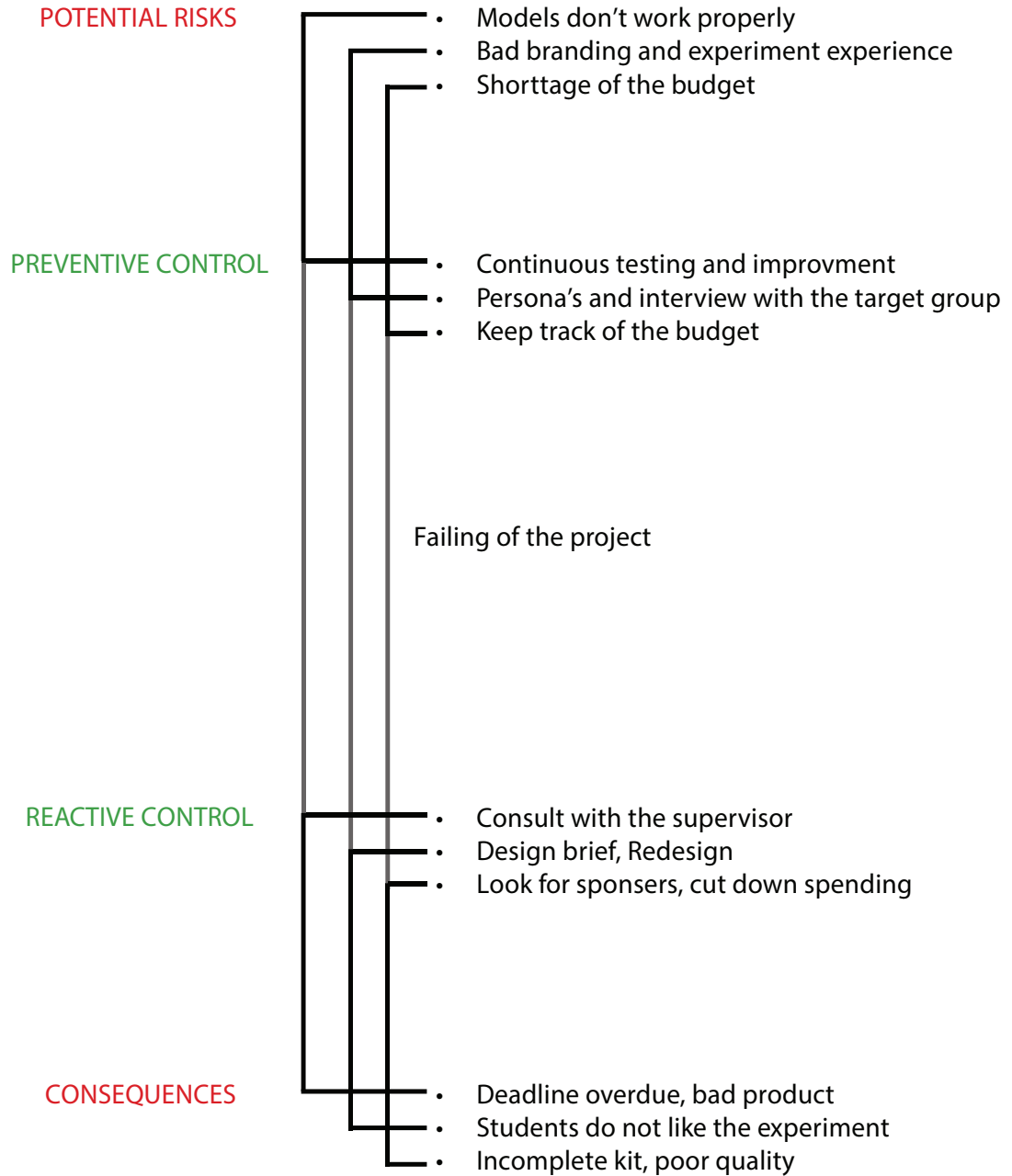



# APPENDIX C

## Gantt Chart

### First version

			February	March						
			25/02 - 3/03 1	4/3 - 10/03 2	11/03 - 17/03 3	18/03 - 24/03 4	25/03 - 31/03 5	1/04 - 7/04 6	8/04 - 14/04 7	
BRANDING										
Windmill ----- Solar thermal	Preparation	Gathering info								
		Brainstorming								
		Design briefing								
	Physics (education)	Science								
	Prototype	Technical design								
		Virtual design								
		Physical prototype								
		Science of the proto								
	Graphic Part	Branding								
		Mock-up								
		Manual						/	/	
	Water	Preparation	Gathering info							
			Brainstorming							
Design briefing										
Physics (education)		Science								
Prototype		Technical design								
		Virtual design								
		Physical prototype								
		Science of the proto								
Graphic Part		Branding								
		Mock-up								
	Manual									
Testing										
Adjustments										



## Updated version

		May				
		29/04 - 05/05 1	6/05 - 12/05 2	13/05 - 19/05 3	20/05 - 26/05 4	27/05 - 02/06 5
<b>Windmill</b>	Prototype					
	Testing					
	Improve					
	Graphic material					
	Exercises					
	Video					
	Blue print					
<b>Solar thermal</b>	Prototype					
	Testing					
	Improve					
	Graphic material					
	Exercises					
	Video					
	Blue print					
<b>Water</b>	Prototype					
	Testing					
	Improve					
	Graphic material					
	Exercises					
	Video					
	Blue print					
<b>House</b>	Design					
	Prototype					
	Arduino					
<b>Packaging</b>	Design					
	Prototype					
<b>General tests (ourselves)</b>					MONDAY	
<b>Concep test (students)</b>						
<b>Improves</b>						
<b>Report (BUDGET)</b>	Draft					
	Review					
	Finish (inDesign)					
<b>Presentation</b>						

	Jun						
7/05 - 02/06 5	03/06/2019 (MONDAY)	04/06 - 11/06 6	13/06/2019 (THURSDAY)	14/06 - 17/06 7	18/06/2019 (TUESDAY)		
	REPORT DRAFT		FINAL REPORT		FINAL PRESENTATION		

## APPENDIX D

### Extended market research

We developed a desk research area to know the existing products that are already in the market. First, we focused on educational toy kits that used the same renewable energies as our STEM kit. Then we studied renewable energies kits used in classrooms.

## EDUCATIONAL TOY KITS

### Wind energy



### GIGO Physics Workshop

- Age 8+
- 37 experiments allow the children to learn the fundamental laws of mechanical physics, gravity, simple machines, acceleration, momentum and more.
- Entry-level introduction kit to learn real-world physics applications.
- Instructions booklet

### GIGO Wind Power

- Age 8+
- Build 2 giant wind turbines, almost 1 meter high.
- The energy generated by the wind can light a LED light on or recharge a battery
- Two styles of wind turbine blades and a gearbox with three different gear ratios for experimenting
- Adjustable angle and wind turbine blades to make the best use of the wind
- Instructions booklet



## GIGO Wind Turbine

- Age 8+
- 5 different models: windmill, electric car, aeroplane, helicopter and truck.
- Windmill blades are an accurate scale representation
- Offers two settings to change blade angles; observers can experiment with which one is more efficient.
- Instructions booklet with the physics principles and applications



## THAMES & KOSMOS Wind Power Energy Science Kit

- Age 8+
- Assemble their own wind turbine
- More than twenty experiments
- It can be used at home and in the classroom
- Instructions booklet

## 4M Windmill Generator Green Science Kit

- Age 8+
- Assemble a miniature windmill generator with a recycled plastic bottle
- Generates power to light a LED
- Instructions booklet



## Solar energy



### GIGO Solar Power 2.0

- Age 8+
- Solar panel that can generate 3 volts of electricity in bright sunlight
- Adjustable, you can experiment by adjusting the panel in different angles to maximize the exposure and generate more power.
- Possibility to design your own solar vehicle.
- Instructions booklet

### GIGO Solar Buggy

- Age 8+
- Introduce basic concepts of Green Energy technology
- The multi-functional motor combines a solar panel, gears and a battery.
- Learn how solar panels convert energy from sunlight into electricity.
- 5 models: solar car, solar helicopter, solar fanjet, wind machine and gyrocopter.
- Instructions booklet



### THAMES & KOSMOS Solar Mechanics Science Kit

- Age 8+
- More than 20 solar-powered models
- Possibility to change the angle, surface area and brightness to compare the energy efficiency
- Includes a unique single-piece solar motor that is composed of a photovoltaic cell and an electric motor joined together in one compact unit.
- Instructions booklet



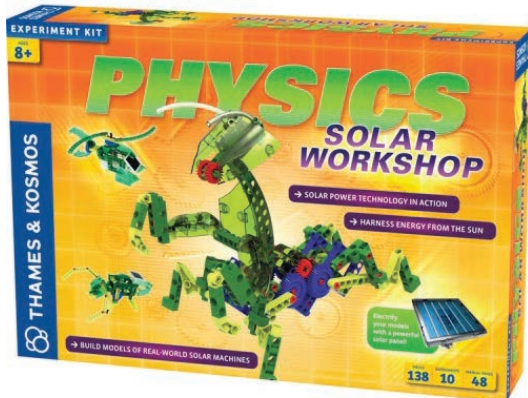

### THAMES & KOSMOS Physics Solar Workshop Construction Kit

- Age 8+
- Teaches about solar energy focusing on photovoltaic cells
- Instructions to build five solar powered models and conduct 10 experiments
- Moving models to demonstrate how gears can convert and transform power for different needs
- Instructions booklet

### OWI Solar Science Mini Kit

- Age 10+
- Six models
- 21 snap together parts for assembly
- Possibility to build a solar car, solar plane, solar airboat, solar windmill, solar puppy or a solar revolving plane
- Instructions booklet



### PICA TOYS Solar Wireless Control Car

- Age 6+
- Assemble a car and a physics circuit.
- Instructions booklet



## Water energy



### GIGO Water Power

- Age 8+
- 15 models propelled by a hydro-pneumatic motor.
- Two different systems: seven models exhibiting the hydro-pneumatic powered system and 8 models exhibiting a water-jet propelled system
- Instructions booklet

### GIGO Water Power mini

- Age 8+
- Uses the principles of air and water pressure.
- Allows angle adjustments to control the model's direction.
- Six models to learn the basic concepts of air pressure and hydrokinetics.
- Instructions booklet

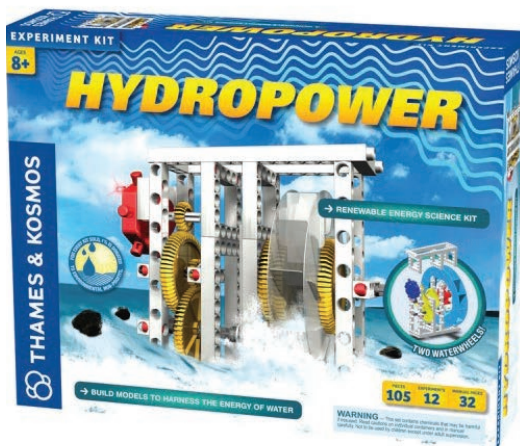

### THAMES & KOSMOS Hydropower Energy Science Kit

- Age 8+
- Create a fully functional hydroelectric power station
- It can be used at home and in a classroom
- Construct their own sawmill, hammer mill, and waterwheel
- Instructions booklet

## House



### GREENEX Green Energy Paradise

- Age 8+
- Build and create a 3D construction
- Five multi construction projects
- Teaches the benefits of alternative energies
- Windmill, solar energy and water wheel
- Instructions booklet

### GREENEX Eco-House

- Age 8+
- Teaches children how to harness the light of the sun to power everyday objects.
- Build a solar- powered house
- Solar windmill, solar door sound, solar LED sign display
- Instructions booklet



## STEM KITS



### DIDAX Renewable Energy Kit

- Grades: 3-8
- Designed to make understanding of renewable and sustainable "green" energy generation an exciting and tactile experience using solar, wind, and water power
- Comes in a modular format with 4 interchangeable monitors to show differing outputs from the 4 interchangeable powerheads
- Designed specifically for the rigours of classroom use
- Includes suggested activities and general teacher's information.

### HORIZON EDUCATIONAL Horizon Energy Box

- Provides a complete understanding of how fuel cell technology interacts with renewable energy sources to create an entirely sustainable power grid
- Introduction to renewable energy: solar panel, wind turbine, temperature cell and hand crank.
- Includes CD with curriculum content for 40 hours of classroom activities.



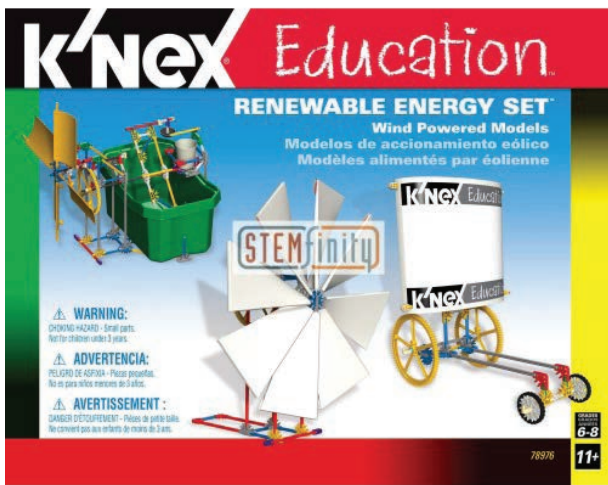

## K'NEX EDUCATION Renewable Energy Kit

- Grades: 5-9
- Supports 6 - 12 students working in teams.
- Designed to address critical science, technology and engineering concepts in the middle school classroom
- Includes 583 K'NEX parts, sufficiently to build 9 renewable energy models
- Includes a teacher's guide

## PICOTURBINE Savonius Vertical Wind Turbine V3

- Each student can create its own blades or modify the design for data analysis on the Turbine's efficiency
- Each STEM Plus interface provides to four alternating power sources to be compared at one time
- Students can see real-time data comparison of RPMs and power output of their alternators.
- The STEM Plus interface shows students exactly how well or poorly they constructed their alternators
- Includes interface and software

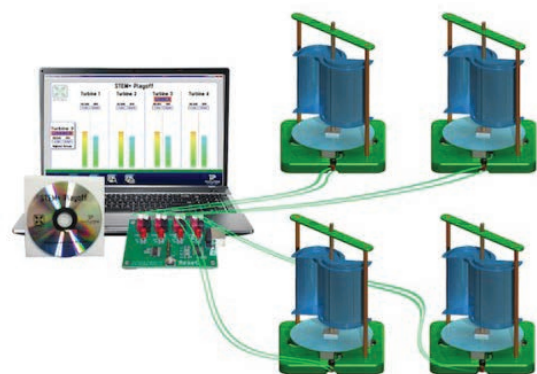

## APPENDIX E

### Extended topic research

#### Windmill

First of all, the windmill consists of three main components:

- The blades
- Generator
- Tower and cable

The windmill uses the wind to turn the blades, which then turn the generator and generate electricity. The generated electricity is carried by cables installed inside the tower and then transferred to the end-user. Following the Betz limit, maximum energy harvested by a wind turbine is 59.3%. The windmill has a considerable number of different designs but can be categorized into vertical axis and horizontal axis windmill.

First, a closer look at the modern horizontal windmill was studied. In this turbine, the blades rotate around an axis that is parallel to the wind direction. In order to make the blades turn, they have a special design with airfoil technology which uses the Bernoulli's principles (Scienceclarified.com, 2019). According to the theory, the sum of pressure, potential, and kinetic energy within any non-viscous, incompressible fluid is always conserved. Therefore, in order to maintain the fluid's energy, as its velocity increases, the pressure will be decreased accordingly.

In this case, the studied fluid is the flowing wind. The airfoil wind blade has two sides, a curve and a flat one. As the wind passes the blade, the wind velocity over the curve side is greater than on the flat side. This phenomenon is then subjected to the Bernoulli's principles, which results in lower pressure on the curved surface and higher pressure on the flat surface. According to the theory of aerodynamic lifting force, a lift perpendicular to the wind is generated on the blade, thus turns it.

As the blades turn, friction between them and the air is created, which directly affects the efficiency of the wind turbine. However, friction can be minimized by implementing a twist and taper along the length of the blades in order to increase the speed at the tip of the blades (where it creates most lift) and increase the overall turning speed. Also, the angle of attack (the angle between the coming wind and the pitch of the blade) and the turbine direction can be modified according to the wind to offer safe yet efficient energy ("Wind Turbine Blade Design, Flat Blades or Curved Blades", 2019).



*Horizontal axis wind turbine*

Different from a horizontal axis design, the vertical axis wind turbine has the blades rotating around a vertical shaft perpendicular with the wind direction.

The vertical axis allows it to capture wind from any direction, thus it does not need a sensing device. The turbine is installed close to the ground and therefore, this turbine can be powered by turbulent wind and makes it easier for maintenance.

However, being on the ground means that it captures less wind and the design itself has more drag than the horizontal turbine, resulting in less efficiency than the horizontal turbine.



*Vertical axis wind turbine*

## **Solar thermal heater**

Solar thermal heater or solar water heater (SWH) is different from most other energy collectors. Instead of generating electricity, it collects heat from the sun's radiation, transfers that heat into water and then supplies our daily use of hot water.

There are two types of SWH: flat plate and evacuated collector.

The flat plate has two main components: the solar panel and the water pipe. The panel is designed carefully in order to absorb the radiation energy from the sun, but at the same time not letting that heat to escape. In order to perform this, the special insulation material is placed inside the panel with a cover of double-glazed glass making the panel a greenhouse and trap the heat inside.

This heat is then transferred to the water pipe, letting hot water flow out. Since the crucial element to improve its power output is the insulation factor, the material has to be carefully selected. For the frame of the panel, aluminium is an ideal option to combine with

copper, mild steel or stainless-steel tubes. The cover glass is tempered glass, which has high durability and a reasonable price, made of thermoplastic such as PVC, Polycarbonate, etc. Then, another layer of glass is added on top with space in between. This space of air acts as an extra insulation layer. So as to bring the heat containment factor further, a special coating is applied to the panel interior. This coating is usually made from copper or aluminium fin. It has high absorbance of solar radiation but a low emittance of thermal radiation, which means that it has better insulation than the matt black coating.



*Flat plate solar water heater*

The evacuated collector has the same working principles as the flat plate, but instead of directly heating the water, the evacuated tubes transfer heat to a copper manifold to exchange the heat with the cold water flowing in, resulting in hot water released of the manifold. By using the vacuum as insulation, the efficiency of Evacuated plate is significantly higher but more expensive than the flat plate.

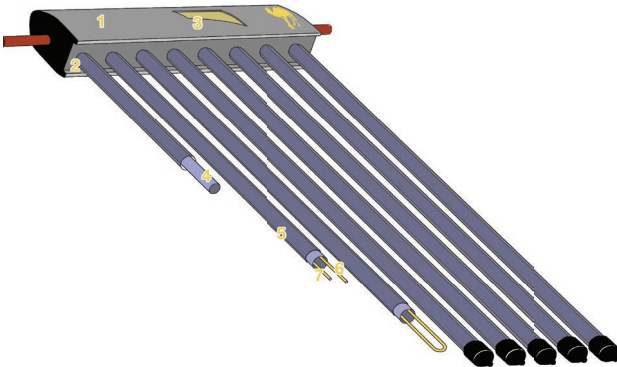

*Evacuated-tube solar water heater*

## Hydropower

Hydropower is the most popular source of electricity around the world. It uses the flow of water to turn a turbine, which powers a generator and produces electricity. Since it uses a river flow as the main source of running water, Hydropower is considered renewable energy and available everywhere in the world. However, the power and design of Hydropower vary in different situations.

### Hydropower stations

There are three types of Hydropower stations:

#### **1. Impoundment**

This station uses a dam to make a reservoir; the water inside is then released falling from the high ground to low ground. Consequently, the kinetic and potential energy of running water is transferred into mechanical energy, turning the turbine and generate electricity.

#### **2. Diversion**

This water turbine does not require a reservoir but instead requires a diversion of the

river in which the turbine is installed. With this method, the turbine does not require a high head nor a very large construction which is more environment-friendly.

Recently, diversion stations have proved its potential to be efficient, easy to install and friendly to aquatic life. One of the most advanced breakthroughs in this system is the invention of the gravitational water vortex power plant.

The vortex turbine uses a special structure that allows the running water to form a low-pressure vortex. The vortex turns a Kaplan turbine inside connected to a generator producing electricity. By installing the turbine onto the river, the electricity is stable and accessible to the local residents. In a vortex power plant, water is fed to a circular basin tangentially, forming a vortex. Both potential and kinetic energy of this whirlpool are then extracted by the Kaplan blade. In order to maximize the power of the vortex, the basin diameter and the outlet orifice has a ratio of 14% for low head and 18% for high head operation (Mulligan & Hull, 2010). Additionally, the position of the Kaplan turbine inside the basin is also crucial. It was found that optimum energy is extracted when the turbine is placed at 65-75% of the total height of the basin from the top position (Dhakal et al., 2015). Overall, the turbine has a simple design and works with an ultra-low head (the height between the water source and the turbine), which is different from the conventional hydropower station. For all of the advantages above, the vortex turbine was chosen as the experiment model in the Energy Wizards project.

#### **3. Pumped storage**

This station is almost similar to the impoundment, except that it stores energy. When on high demand for electricity, the water



*Impoundment hydropower*

is released from the reservoir to generate electricity. However, when the needs are low, the water will be pumped back to the upper reservoir, restoring the potential energy.

### **Turbine blades design**

The turbine blades operation is driven by two main mechanisms, thus divided into two types of water turbine:

#### **1. Reaction turbine:**

- The turbine blades are totally submerged in the flow of the water and enclosed within a pressurized casing.
- Powered by the aerodynamic lifting forces that are generated due to the pressure difference between two sides of the blades, creating an aerodynamic lifting force.
- Powered by the kinetic energy of running water.

*Francis turbine:* The highest power is achieved at medium head and medium flow rate. The turbine is submerged in the water and the pressure difference between two sides of the blade causes the motion of the turbine.



*Diversion hydropower*



*Francis turbine*





*Kaplan turbine*

*Kaplan turbine:* The turbine optimum position is at low head with a high flow rate of water. The water changes pressure as it moves through the turbine, then the turbine is turned by the difference of pressure.

## 2. **Impulse turbine:**

- The low-velocity water is accelerated into the high-speed jets.
- The jet hits the curved spoon or bucket-shaped turbine.
- Mechanical power from the kinetic energy.

*Pelton wheel:* The turbine operates in the condition of high head and low flow rate. High-pressure water is shot onto the cup of paddle geometry, thus turns the runner. Multiple nozzles can be installed to increase efficiency.

*Turgo turbine:* It is used at medium to high head and low flow rate. The high-speed water jet is directed to the runner, transfer kinetic energy of water to mechanical energy.

*Cross-flow turbine:* Operation is conducted at low head, medium to high flow rate. Inlet water passes through the turbine twice. First time at the guide vane and second time at the exit hole. By this special flow of water, it gains better efficiency.

## Conclusion

In conclusion, we need to use a turbine blade that does not require a high head. Besides, a high flow rate can be achieved by a pump. Therefore, we chose the Kaplan turbine to be used in the experiment.



*Pelton wheel*

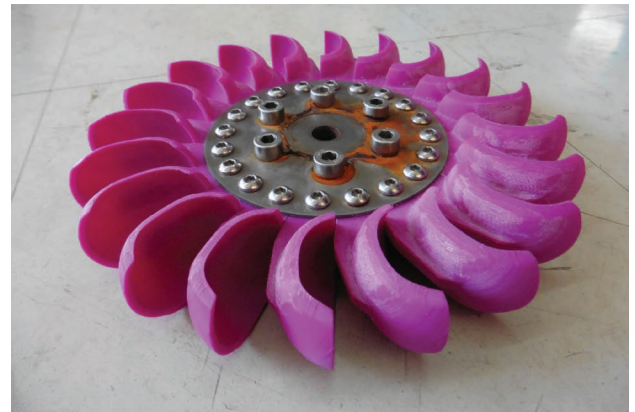

*Turgo runner*



*Cross-flow turbine*

# APPENDIX F

## Extended previous years' research

### Windmill

#### Conclusions from the report

In 2017, the EON team, the first Energy Wizards group from the EPS programme of the University of Antwerp, had the main objective to create products to make science classes more interesting and to teach children about STEM-related topics.

The solution they chose was to develop a workshop about Renewable Energy using a windmill as a resource to visualise the concepts. After all the development stages of the project, the EON team conducted the usability test with the target group, students from 15 to 16 years old from Belgian secondary schools.

The workshop was held in the school Heilige Familie in Berchem, in a two-hour meeting with six students from an ASO science class. The pupils received toolboxes with all the necessary materials for the experiment and the first step was to design and cut different shades of blades for the windmill. After that, they had to measure how much voltage was produced by combining the shades, number, and position of the blades.

The voltages gathered on the windmills were used to launch planes from each group, the group whose plane flew farther won since they had the best combination of blades and produced the highest voltage.

According to the teacher and students' feedbacks, they had fun during the workshop, it was inspiring and productive. However, the EON team noticed from the observations and also from the feedback that some changes could be performed:

- Students do not read before they act;
- Provide more space for the students to experiment and express their creativity;
- Control the time, a class hour has maximum of 50 minutes;
- Some components must be more self-explanatory.

#### FLOW team conclusions

From the EON report and also the test with the Windmill that we performed, we drew some conclusions. Firstly, about the corporate identity, all the graphic materials are well designed and follow the same visual identity, and even the prototype and packaging use the brand elements, the colours, and the logo. Secondly, even though the windmill has a great product design, the blades are different from the usual Windmills, but it would be easier to explain their performance if they were the same. Also, the blades connections could be improved functionally and aesthetically. Lastly, the launching device is really fun, but it is not the best solution to use as an example of an application of the energy generated, and also because it holds students' attention to the planes and the competitions, instead of making them talk about the windmill.

### Solar Thermal

#### Conclusions from the report

In the second year of Energy Wizards a new team of EPS students, the H2OME team developed two more experiments for the Renewable Energies workshop. The first Project was a Solar Thermal Panel that was also tested at Sint Willebrord de Heilige Familie school, in a 50-minute meeting with seven fourth grade students.

The pupils worked individually or in pairs, heating the water in the solar panel using lamps and measuring the final temperatures of the water. During the experiment, when the students were waiting for the water to heat,

the H<sub>2</sub>OME team prepared some exercises to help them to understand the principles and applications of the solar heater. The students also had to make some calculations; however, these were difficult and they required assistance to solve them. The lack of time was an obstacle as well.

The H<sub>2</sub>OME team drew some conclusions from the observations:

- Water spillage in the prototype, when students had to put it into the panel;
- Lampshades distorted due to the limitations of the 3D printing process;
- Exercises sheets had advanced level;
- Lack of time to solve the problems during the class.

### **FLOW team conclusions**

The solar thermal prototype is not a good design. The blue box is simple and it could have used better branding elements, the graphic materials are also poor and there is no packaging. About the toolkit, the team could have provided all the necessary items for the experiment, such as thermometer, measuring cups and funnel, instead of making this a school responsibility.

The method to fill and clear the tube is inefficient, the water spills when the funnel is used and it moves and drops while it is heated because the tube is open. Besides that, the students need to use air pressure to remove the water, but since there are no other options, they have to blow the tube with their mouths. The experiment did not use any element or context to apply and explain the use of solar energy.

## **Water turbine**

### **Conclusions from the report**

The second experiment developed by the H<sub>2</sub>OME team was the Water Turbine, and the prototype was also tested with the fourth grade ASO high school students of the Sint-Wille-

broed Heilige Familie, during a 50 minutes class.

Working in pairs, the pupils had to test the water speed changes using the Water Turbine and combining different nozzle diameters with a one-meter tube connected to a bottle filled with water. After the students collected all the data, they could complete the exercises about the influence of the nozzle on potential/ kinetic energy, in the worksheets that were prepared by the teacher, Christophe Heysels, as part of his teacher's training.

The experiment had problems with the Arduino during the measurements and the students required to note every value. While one student was holding the bottle one meter above the turbine the other had to note the value of instant speed displayed on the LCD-screen, at the same time it was necessary to have someone of the H<sub>2</sub>OME team or Christophe to track time. This led to the following conclusions:

- Problems with the Arduino probably because some water had reached the buttons;
- The measured values were displayed too quickly and the students did not have sufficient time to write them;
- One turbine for eight students was not sufficient, they should have increased the number of turbines.

### **FLOW team conclusions**

The product design of the turbine and the house are poor, the quality of the final prototypes is unsatisfactory and they look unfinished, once the wires and the vinyl tape are visible and there is no painting. The base could be covered with grass.

The team should have used more graphic elements and brand colours, the graphic materials are also poor and there is no packaging.

A large number of components in the experiment made it difficult for the students to handle everything since they had to take notes of the experiment's results at the same time as they were performing the tasks.

## APPENDIX G

### Technopolis

The Flow team visited Technopolis the first week of March with the objective of conducting a more detailed investigation of the target group of the experiment, as well as other variables that we must take into account when accomplishing the project.

#### What is Technopolis?

Technopolis is an interactive science museum, which is located in Mechelen. Its purpose is to bring science and technology to people, informing and sensitizing children and adults about its importance both in the present and in the future. In this way, Technopolis allows you to discover the wonderful world of exact and applied sciences through a large number of games and entertainment.

Furthermore, this museum offers us a wide variety of alternatives depending on whether we are visitors, we belong to a school either as students or teachers, or if we will attend a science event.

Whoever you are, you are invited to spend an exciting day at Technopolis, where you will find experiments, shows, demonstrations, and curiosities about science that will make your visit unforgettable:

- **PLAY (8 years and older):** This exhibition is full of thunderous rhythms and wonderful sounds. In this way, children have fun while playing different instruments and learn the physics of sounds.
- **Sports 2.0 (8 years and older):** Expand your boundaries adding some new technologies to your sports experience. Thus, you can experience virtual paragliding as well as climbing to the top yourself in augmented reality.

- **Xplora (8 to 14-year-olds):** Discover all your talents, detect what you are good at and what profession you like best, all while having a great time.

- **Main Exhibition (8 years and older):** A mix of original and interactive exhibits that show the role science and technology play in our daily lives. Besides the basic principles of science, there are also new technologies on offer such as augmented and virtual technology.

- **Children's Science Centre (4 to 8-year-olds):** Young children can go on a journey of discovery through the City, the Park, and the Wharf and they also learn about the Human Body. Moreover, they can now create their own playroom with the Hop Up Playground.

- **Science Garden (8 years and older):** Head outside and fill your lungs with some refreshing science in the Science Garden, where you will find a series of amazing experiments, such as a living bridge and a giant board for playing chess.



It is noteworthy that all of this is available in three languages: Dutch, French, and English, which helps make knowledge accessible to all, no matter where you come from.

### **And what about your results of the experiments?**

There is a large variety of surprises at Technopolis, one of which is the RFID (Radio Frequency Identification) bracelet.

Once you enter Technopolis, choose a bracelet depending on the size of your wrist, then place it against the scanner of the exhibition you intend to try, enter your personal data and... Voilà! In a few days, you will receive the results of the experiments you have performed in your mailbox.

### **Now, we can talk about parents and their main role in Technopolis**

Parents also are involved in the play and fun of their children, with the purpose of learning at the same time that they are having fun. Besides, they help their children in order to know the physics behind the experiment as well as the technology.

During our visit, we observed that while adults usually read the information that contains the explanation of the experiment, children prefer to try the trial and error method. If the experiment does not provide immediate results or does not allow interaction with it, the children are bored and leave quickly.

### **Teachers also become experimenters!**

Since they have the possibility to use experiments as a tool for children's learning in a didactic, simple and visual way.

In this sense, they can increase their knowledge of physics, mathematics, chemistry, and biology. This helps them relate the logical-mathematical background with a friendly and stimulating environment.

### **So, what is the most attractive to children?**

Kids feel highly attracted by the collective games in which their friends are also involved, as well as the presence of several inputs and outputs, water games and the interaction with the experiment in a continuous way.

### **All this has led us to make some conclusions...**

Firstly, we know first-hand which experiments attract the most to the children, what is the first thing they see and play, the degree of interaction experiment-child, experiment-adult and experiment-child-adult, the time they use playing experiments, the interest in individual or collective games and so on.

In addition, Technopolis is associated with numerous schools. In this way, students have the possibility to attend workshops, in which experimenting becomes part of their play.

Group games help them to solve problems together until they reach the optimal solution. What is different, new and exclusive appeals to them: scientific experiments allow children to discover and build new environments, being able to link them to the theory they have learnt and developed in school.

## **Cross Media in Technopolis**

### **What is the target group and its mission?**

Definitely, the main target group is children. From here, it is subdivided into parents and schools as well. In this way, Technopolis has been growing: children enjoy the experiments and have fun, transmitting their feeling to their families, friends, and teachers.

Similarly, FLOW presents the same target group as Technopolis, so we have taken into consideration various variables to connect mathematics, physics, chemistry, and biology with the aim of creating a stimulating and fun environment. In this sense, our mission is that our advertising becomes a satisfied client

### **How does Technopolis reach the target groups?**

Technopolis reaches target groups through various media, one of which is Facebook, in which it adds pictures, videos and several publications in order to reach everyone, regardless of age or nationality.

Likewise, there is the Technopolis website which they announce new shows, exhibitions, events, summer camps and much more. In addition, if you buy your ticket online you will have a guaranteed discount, a factor that encourages attendance at the museum.

Then, *s cool* magazine was created to contact the schools and transmit all the information about the workshops and experiments that take place at Technopolis.

Last but not least, word of mouth is the most important asset of this place, since it reaches children, parents and teachers. In reality, what could be better?

### **How is the Technopolis corporate identity?**

Its characteristic symbols and striking colours are what encompasses the Technopolis style.

Directed to both children and adults, its graphic design consists of very bright colours, such as pink, orange, blue, red, green and yellow, as well as its fun shapes that allude to scientific reasons.

As a result of all this, the museum manages to capture the attention of the public by transmitting accessibility, versatility and dynamism.

Consequently, its logo can be observed in various spaces and objects: experimental rooms, staff clothing, bags, experiment materials, informative articles, and so on.

### **What should we learn from Technopolis?**

The graphics style is clear and simple, which allows the accessibility of the museum to any age range.

Its popularity is due to the constant flow of different exhibitions and exhibitions, media and schools, as well as all the fun, simple and animated multimedia messages.

With all this, we can conclude that Technopolis appeals to the five senses to attract as well as to satisfy with their experiments.



# APPENDIX H

## Brand book

### Main Version



### Logo usage



### Construction

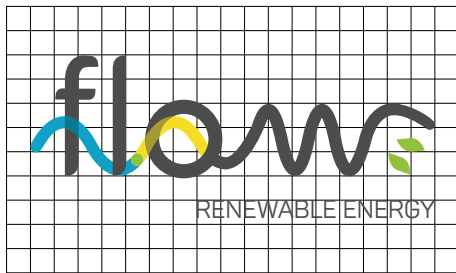

### Scale

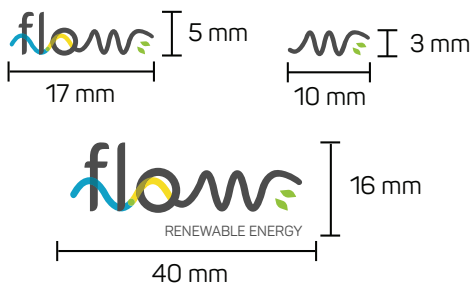

### Brand colors

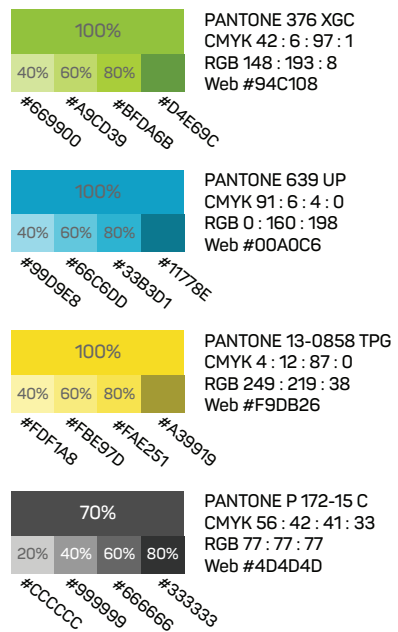

### Clear space

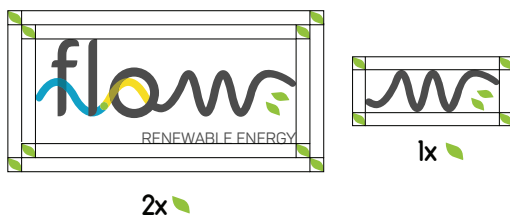

## Black and white



## Shades of grey



## Outline

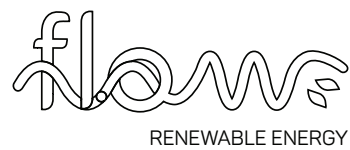

## White option



## Monochrome



## Brand colours backgrounds





# Typography

**Panton** Aa Bb Cc Dd Ee Ff Gg  
 ABCDEFGHIJKLMNOPQRSTUVWXYZ  
 abcdefghijklmnopqrstuvwxyz  
 1234567890

Thin  
 Light  
 Regular  
 Semi Bold  
**Bold**  
**Extra Bold**  
**Black**

**Arciform** Aa Bb Cc Dd Ee Ff Gg  
 ABCDEFGHIJKLMNOPQRSTUVWXYZ  
 abcdefghijklmnopqrstuvwxyz  
 1234567890

## Icons

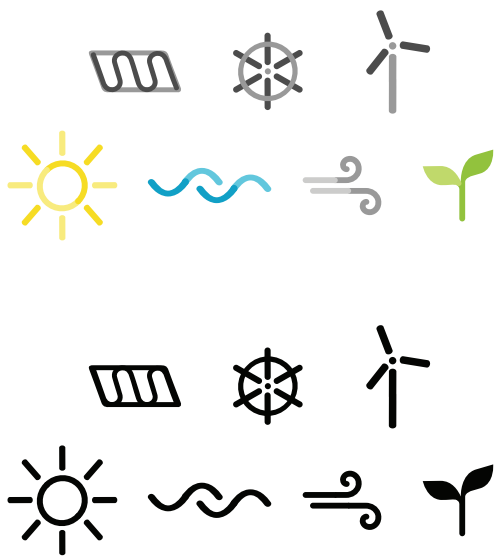

## Unacceptable usage



APPENDIX I  
Graphical materials

Students manual

flow

Solar  
thermal  
experiment

# Schedule

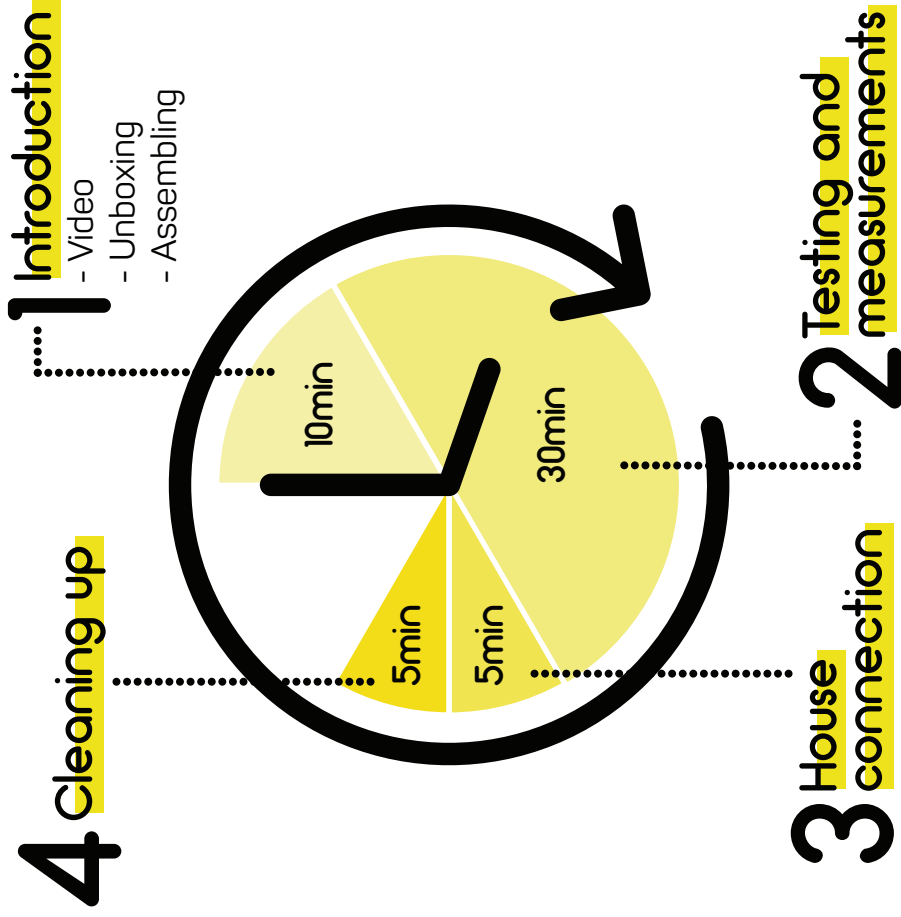

# Steps

Assemble the experiment following the instructions in the video.

Fill one cup with water, measure its temperature and write it down in the exercises sheet.

Measure 10ml of water with the syringe and fill the tube, pump air with the syringe to be sure that all the water is inside the box, and then close the tube.

Choose the 36W light bulb to start the experiment.

Set the correct distance between the panel and the lamp, set up an alarm for 15 minutes and turn on the lamp at the same time. While waiting, complete the exercises sheets.

When the time is over, use the syringe to pour the water into the empty cup and measure its temperature again.

Put data into the worksheet and start the calculations.

Restart the experiment with the 53W light bulb. Remember to use the same distance between the light bulb and the panel to compare the results.

Use the heated water with the house.

1

2

3

4

5

6

7

8

flows



# Windmill experiment

# Schedule

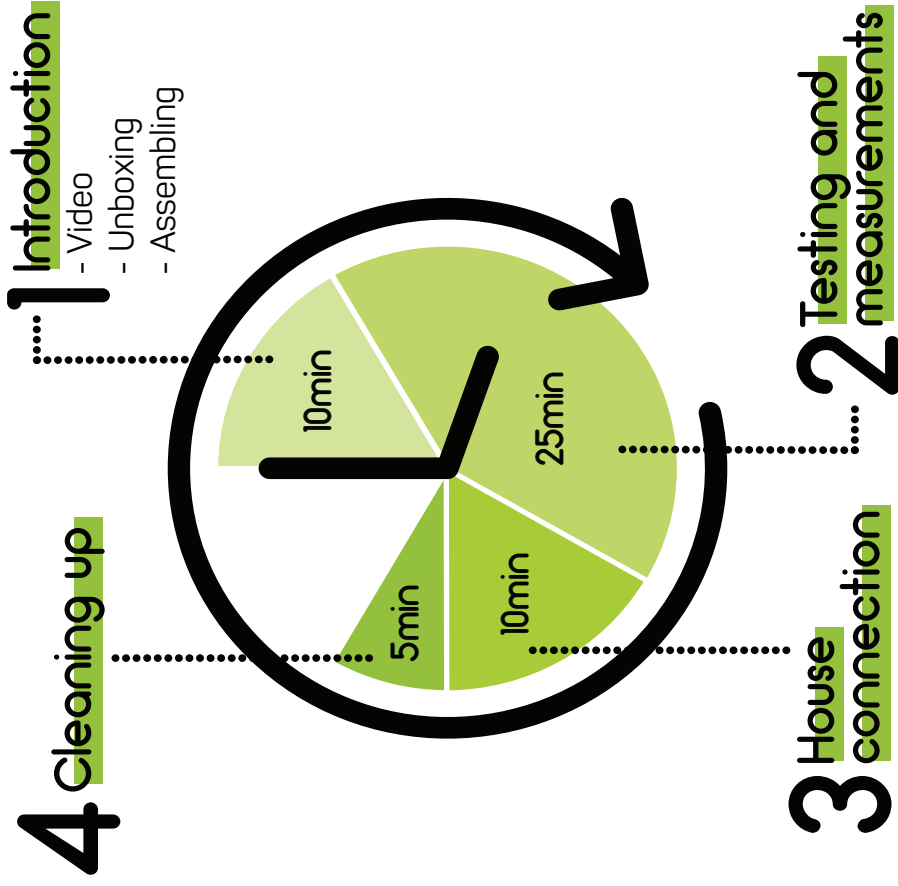

# Steps

- 1 Assemble the experiment following the **instructions in the video**.
- 2 Choose the **number and type of blades** for the windmill.  
Determine the **angle** you want them to be positioned in.  
Assemble the blades in the windmill.
- 3 Place the fan **20 centimetres** away from the windmill' base.  
**Turn it on**.
- 4 **Measure the voltage** with the multimeter and write down the measurements.
- 5 Test the 2 types of blades in **different configurations**, with 2, 3 or 4 blades in each angle, then, measure the voltage (in millivolts) generated.
- 6 **Write down** in the exercises sheets the voltage for each configuration in the best angle.  
Complete the **additional exercises at home**.
- 7
- 8 Connect your best configuration to the **house**.

flow



# Hydro power experiment

# Schedule

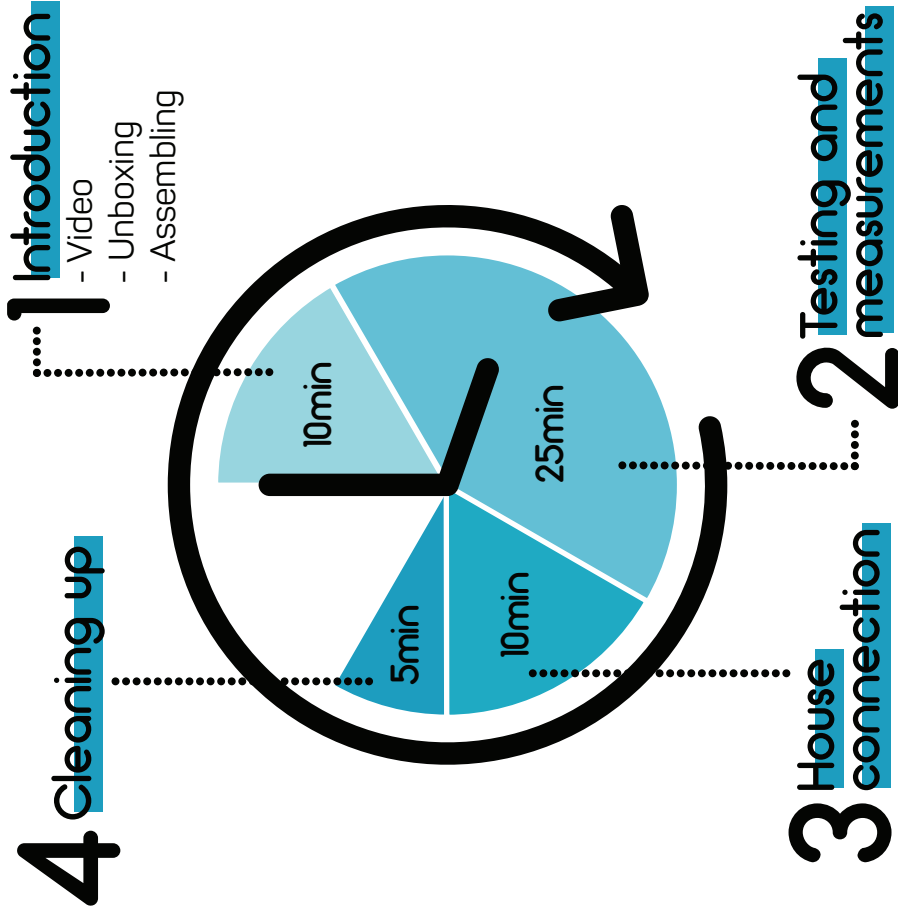

# Steps

- 1
- 2
- 3
- 4
- 5
- 6
- 7
- 8

Assemble the experiment following the [instructions in the video](#).

Choose the [nozzle](#) for the inlet valve.

Fill the [water pool](#) with about 900 ml of water.

Turn on the [flow meter](#) and connect the wires of the generator to the multimeter.

Start the [drill pump](#) and observe the flow meter. Try to keep the flow constant, then take note of the flow rate and the output voltage.

Change the [nozzle](#) and repeat the steps as the above.

Complete the [additional exercises at home](#).

Connect your best configuration to the [house](#).





Teacher guide

# flow

## TEACHER'S GUIDE

Solar  
thermal  
experiment

## What is this experiment?

The **Solar Thermal experiment** is one of the three **Flow workshops**, based on STEM education. The purpose of these workshops are to show alternative sources of energy, specifically solar, hydraulic and wind energy, as well as to teach the physics principles associated.

The **Solar Thermal experiment** has different configurations in which the students can study the efficiency and the heat transfer by measuring the temperature difference of the water. It will help the students to understand how solar panels work, and to place the theoretical knowledge about solar energy into a real-life context.

## Components for the experiment

### INCLUDED IN THE TOOLKIT:

- 1 solar thermal panel;
- 1 base;
- 2 measuring cups (35ml);
- 2 corks;
- 1 syringe (10ml);
- 1 waterproof thermometer;
- 2 light bulbs (36W / 53W);
- 1 printed manual about the experiment;
- 1 guide for the teacher;
- QR code to access the online teacher's guide, manual for the students and exercises files to print and the video.

### NOT INCLUDED:

- 1 Desk lamp.

## Schedule

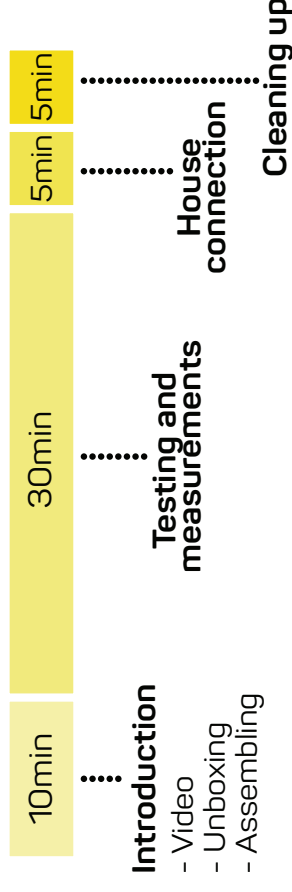

## Steps

- 1-** Assemble the experiment following the instructions in the video. Fill one of the cups with water and measure the initial temperature;
- 2-** Measure 10ml of water with the syringe and fill the tube. Pump air into the tube with the syringe to be sure that all the water is inside the box and put the corks;
- 3-** Choose the 36W light bulb to start the experiment.
- 4-** Set the correct distance between the panel and the lamp. Set up an alarm for 15 minutes and turn on the lamp at the same time. While waiting, complete the exercises sheets;
- 5-** When the time is over, use the syringe to pour the water into the empty cup and measure its temperature again;
- 6-** Put data into the worksheet and start the calculations;
- 7-** Restart the experiment with the 53W light bulb. Remember to use the same distance between the light bulb and the panel to compare the results;
- 8-** Use the heated water with the house.

## Assembling instructions

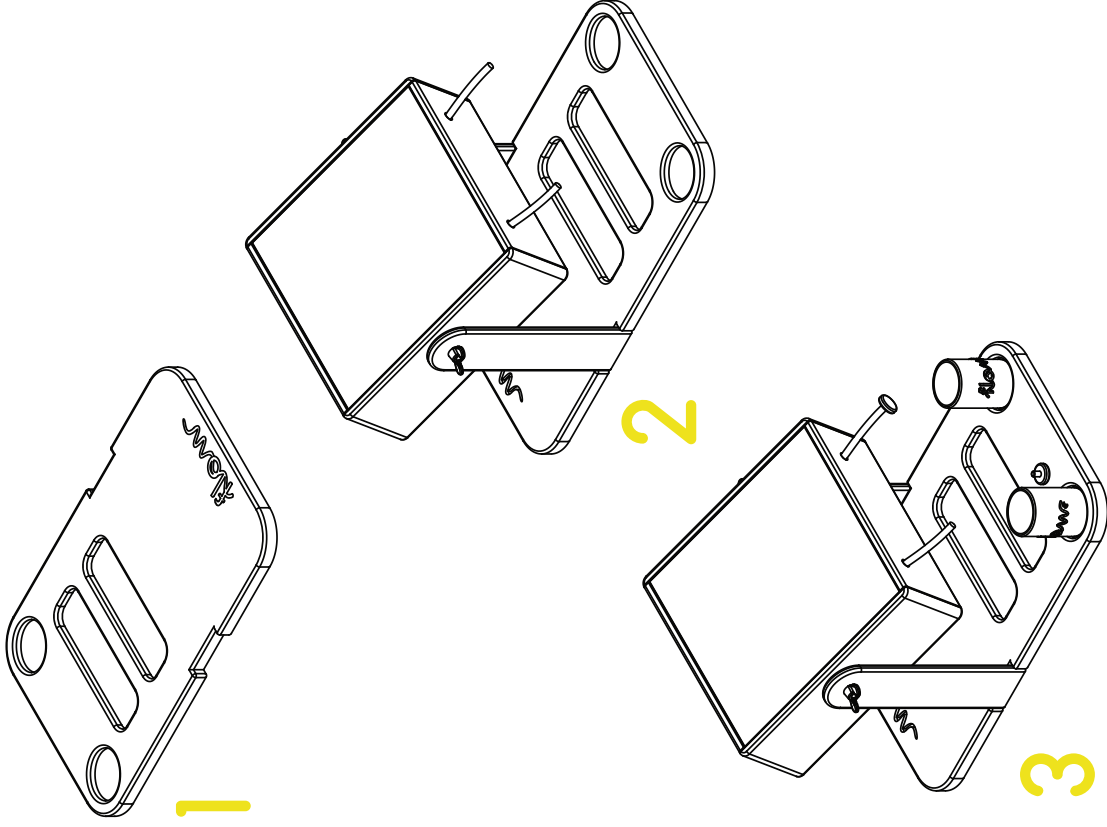

## Download materials

All the teaching material that support the **Solar thermal experiment** are available online, and they can be downloaded using the QR code:

Available files:

- Teacher's guide
- Manual for the students
- Exercises and model answers
- The video



flow

# TEACHER'S GUIDE

Windmill  
experiment



## What is this experiment?

The **Windmill experiment** is one of the three **Flow workshops**, based on STEM education. The purpose of these workshops are to show alternative sources of energy, specifically solar, hydraulic and wind energy, as well as to teach the physics principles associated.

The **Windmill experiment** has two types of blades that can be placed in different angle configurations. A fan powers the windmill and the students can measure the generated voltage. It will help the students to understand how windmills work, and to place the theoretical knowledge about wind energy into a real-life context.

## Components for the experiment

### INCLUDED IN THE TOOLKIT:

- 1 windmill;
- 16 blades (2 types, 8 of each);
- 2 connectors (for 3 and 4 blades);
- 1 base;
- 1 printed manual about the experiment;
- 1 guide for the teacher;
- QR code to access the online teacher's guide, manual for the students and exercises files to print and the video.

### NOT INCLUDED:

- 1 Multimeter;
- 1 Fan.

## Schedule

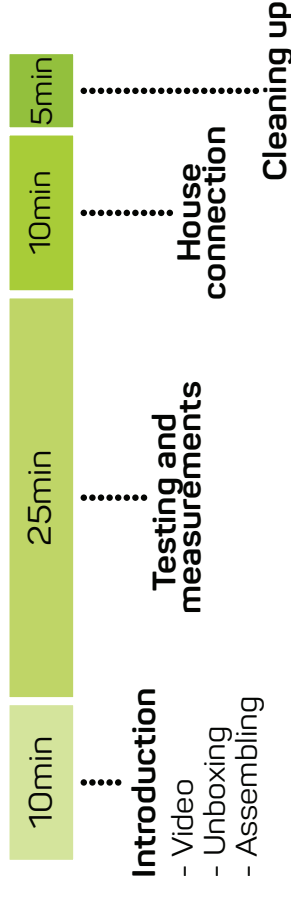

## Steps

- 1- Assemble the experiment following the instructions in the video;
- 2- Choose the number and type of blades for the windmill. Determine the angle you want them to be positioned in. Assemble the blades in the windmill;
- 3- Place the fan 20 centimetres away from the windmill' base. Turn it on;
- 4- Measure the voltage with the multimeter and write down the measurements;
- 5- Test the 2 types of blades in different configurations, with 2, 3 or 4 blades in each angle, then, measure the voltage (in millivolts) generated;
- 6- Write down in the exercises sheets the voltage for each configuration in the best angle;
- 7- Complete the additional exercises at home;
- 8- Connect your best configuration to the house.

## Assembling instructions

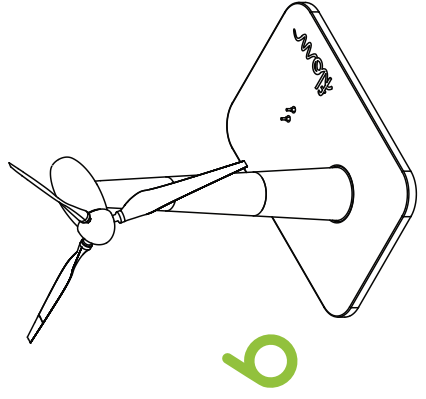
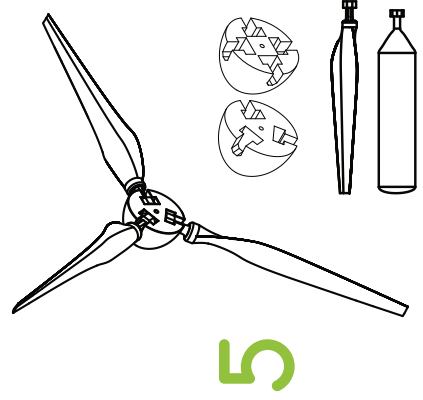
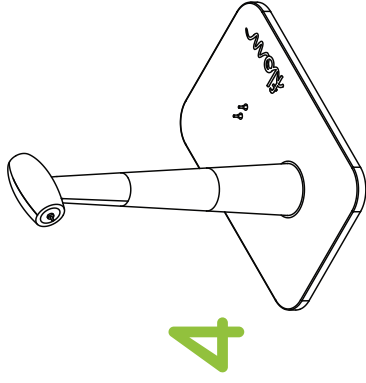
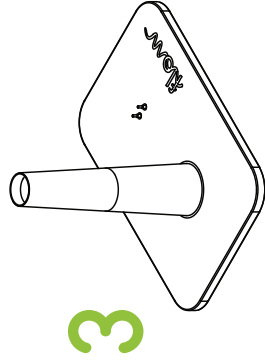
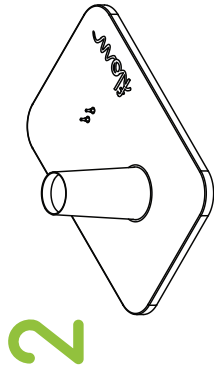
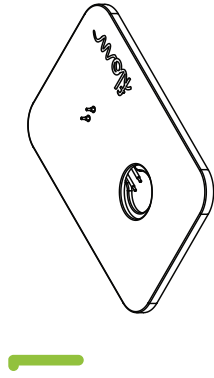

## Download materials

All the teaching material that support the **Windmill experiment** are available online, and they can be downloaded using the QR code.

Available files:

- Teacher's guide
- Manual for the students
- Exercises and model answers
- The video



# flow

## TEACHER'S GUIDE

### Hydro power experiment



## What is this experiment?

The **Hydropower experiment** is one of the three **Flow workshops**, based on STEM education. It is a water turbine in which the students can change the nozzles, the propellers, and the flow of the water, powering it with a drill. This experiment will help the students to understand how hydropower turbines work, and to place the theoretical knowledge into a real-life context.

## Components for the experiment

### INCLUDED IN THE TOOLKIT:

- 1 turbine basin;
- 1 generator with casing and electronic wire;
- 1 glass cover;
- 1 turbine blade;
- 4 nozzles;
- 2 plastic tubes with hose connectors;
- 1 waterpool;
- 1 flowmeter;
- 1 pump;
- 1 base plate;
- 1 miniature mountain;
- 1 printed manual about the experiment;
- 1 guide for the teacher;
- QR code to access the online teacher's guide, manual for the students and exercises files to print and the video.

### NOT INCLUDED:

- 1 Drill;
- 1 Multimeter;
- Volume cup.

## Schedule

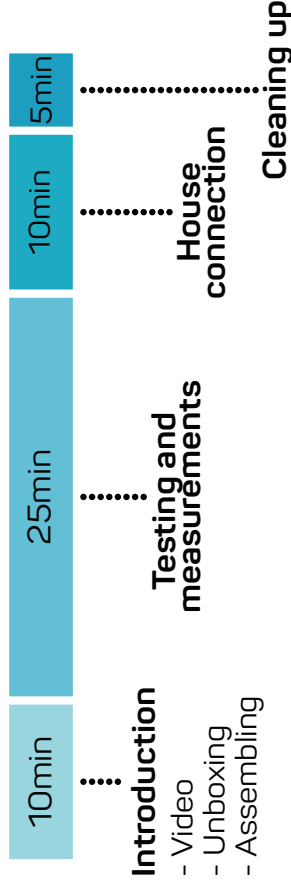

## Steps

- 1- Assemble the experiment following the instructions in the video;
- 2- Choose the nozzle for the inlet valve;
- 3- Fill the water pool with about 900 ml of water;
- 4- Turn on the flow meter and connect the wires of the generator to the multimeter;
- 5- Start the drill pump and observe the flow meter. Try to keep the flow constant, then take note of the flow rate and output voltage;
- 6- Choose a different nozzle and repeat the steps as the above;
- 7- Complete the additional exercises at home;
- 8- Connect your best configuration to the house.



## Assembling instructions

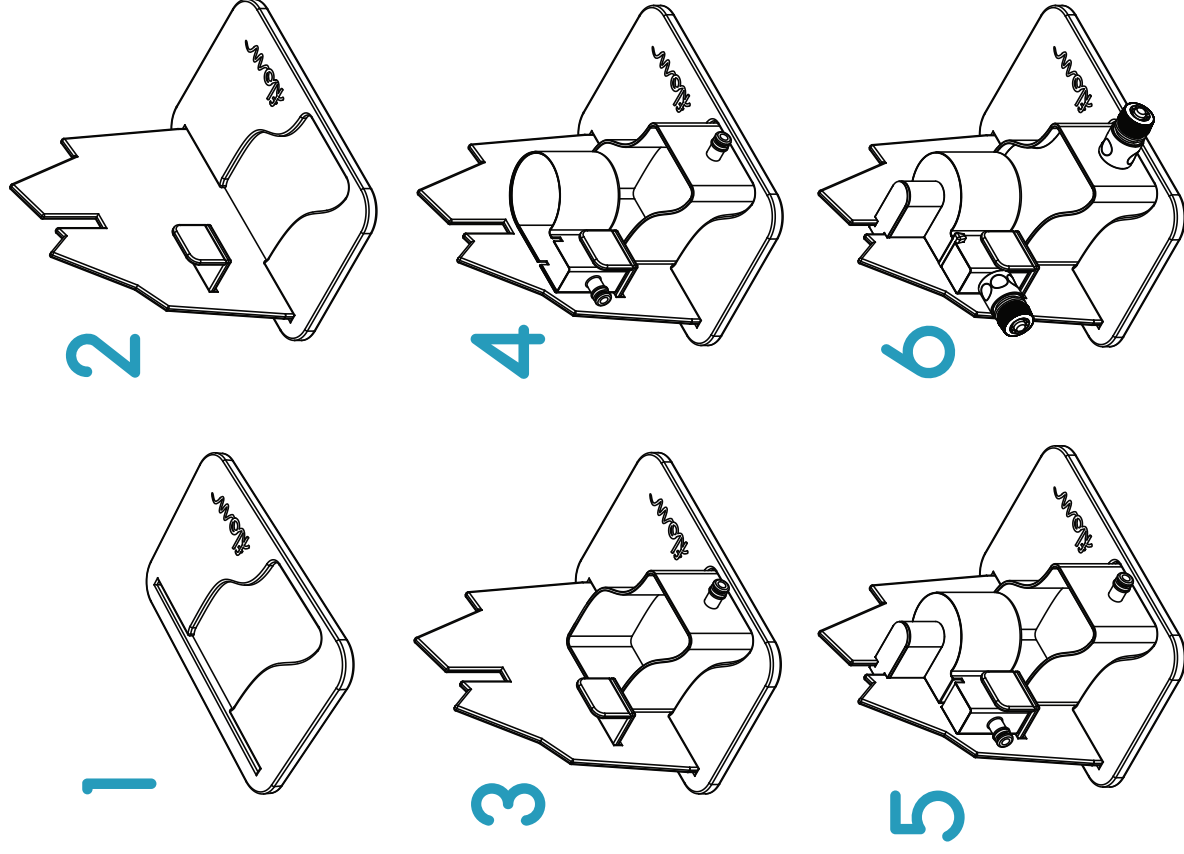

## Download materials

All the teaching material that support the **Hydropower experiment** are available online, and they can be downloaded using the QR code:

- Available files:
- Teacher's guide
  - Manual for the students
  - Exercises and model answers
  - The video





# Exercises

# Exercises

## SOLAR THERMAL



Name: \_\_\_\_\_ Class: \_\_\_\_\_ Date: / /

Write down the experiments datas

**1** Initial temperature:  
Lamp 1:  
Distance:  
Time: 15 minutes  
Final temperature:

**2** Initial temperature:  
Lamp 2:  
Distance:  
Time: 15 minutes  
Final temperature:

1. Shower time is 15 minutes and the temperature that you want to use is 42°C. The flow rate of shower is 8 litres per minute. The temperature of the water results from a mix of cold water and hot water. Knowing that the temperature of cold water is 15°C and hot water is 60°C, calculate how much cold and hot water you need to mix in order to achieve the desire temperature in mass.

In this question use:

- The calculation of heat transfer:  $Q = m \times c \times \Delta T$
- Water density is **997 kg/m<sup>3</sup>**

**Abbreviation:**

- **Q:** Heat gained or heat lost (Joules)
- **m:** Mass (kg)
- **c:** Heat capacity (J/°C)
- **ΔT:** Temperature difference (°C)

2. Measure the final temperature of the water after heating inside of the solar panel.
  
3. After the measurement, calculate the heat gained by the water, considering that there is 10 ml of water inside the tube
  
4. Calculate the heat energy in Joules that is produced by the bulb during the 15 minute experiment assuming that all of the power input is converted into heat energy.
  
5. Compare the result from question 3 with the heat gain that was calculated in question 2. Is there a difference? If yes, calculate the efficiency of the panel.
  
6. Which of the two light bulbs (36W and 53W) would be the best representation of the sun? Knowing that when the sun's radiation reaches the Earth surface, it provides a power of  $1000\text{W}/\text{m}^2$ .

# Exercises

## WINDMILL



Name: \_\_\_\_\_

Class: \_\_\_\_\_

Date: / /

Write down the experiments datas

**1** Number of blades:  
Blades shape:  
Best angle:  
Voltage:

**2** Number of blades:  
Blades shape:  
Best angle:  
Voltage:

**3** Number of blades:  
Blades shape:  
Best angle:  
Voltage:

**4** Number of blades:  
Blades shape:  
Best angle:  
Voltage:

**5** Number of blades:  
Blades shape:  
Best angle:  
Voltage:

**6** Number of blades:  
Blades shape:  
Best angle:  
Voltage:



1. Draw a graph that shows the relation between the output voltage and the blades angles.

2. What do you think is the explanation for the different results? Knowing the number of wings, angles and blades shapes are involved.

# Exercises

## HYDROPOWER

Name: \_\_\_\_\_ Class: \_\_\_\_\_ Date: / /

Write down the experiments datas

- |          |                                               |          |                                               |          |                                               |          |                                               |
|----------|-----------------------------------------------|----------|-----------------------------------------------|----------|-----------------------------------------------|----------|-----------------------------------------------|
| <b>1</b> | Nozzle:<br>Turbine:<br>Flow rate:<br>Voltage: | <b>2</b> | Nozzle:<br>Turbine:<br>Flow rate:<br>Voltage: | <b>3</b> | Nozzle:<br>Turbine:<br>Flow rate:<br>Voltage: | <b>4</b> | Nozzle:<br>Turbine:<br>Flow rate:<br>Voltage: |
|----------|-----------------------------------------------|----------|-----------------------------------------------|----------|-----------------------------------------------|----------|-----------------------------------------------|

1. Calculate the kinetic energy of water in the turbine and the height of mountain needed in order to achieve the measured flow rate. The tube's area is  $9.5 \times 10^{-5}$ , water volume is 900 ml, and water density is  $997 \text{ kg/m}^3$ .

In this exercise, you should use conservation of energy. In this case, when the water is on top of the mountain, there is potential energy but the water does not move, so there is no velocity, or kinetic energy. As the water runs down the hill, the potential energy is gradually converted to kinetic energy as the water gains speed. When the fluid reaches the bottom of the mountain and flows to the turbine, the kinetic energy is at its maximum value and there is no potential energy.

### Formulas:

- $m = d \times V$
- $Q = A \times v$
- $E_p = m \times g \times h$
- $E_k = 1/2 \times m \times v^2$

### Abbreviation:

- **m**: Mass of the water (kg)
- **d**: Water density ( $997 \text{ kg/m}^3$ )
- **V**: Water volume (litre)
- **v**: Water velocity (m/s)
- **Q**: Flow rate ( $\text{m}^3/\text{s}$ )
- **A**: Surface area of the tube ( $\text{m}^2$ )
- **$E_p$** : Potential energy (Joules)
- **$E_k$** : Kinetic energy (Joules)
- **g**: Gravitational acceleration ( $9.8 \text{ m/s}^2$ )
- **h**: Height of the mountain (m)



## 1. Calculations

2. Which nozzle gives the highest energy output? Can you explain why?

3. You can change the flow rate of water by adjusting the power of the pump. How does the flow rate affect the energy output? Can you make a graph showing the relationship? Use the blank space in the back side of the paper to draw.

# Brochure

flow

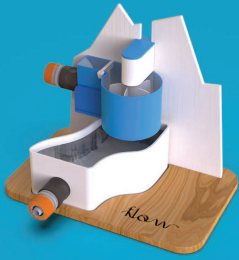

## Hydropower

The Hydropower experiment contains a water turbine in which the students can change the nozzles, the propellers, and the flow of the water, powering it with a drill and the students can measure the generated voltage.

This experiment will help the students to understand how hydropower turbines work, and to implement the theoretical knowledge into a real-life context.



flow  
RENEWABLE ENERGY



## What's included?

- 1 Windmill experiment
- 1 Solar Thermal experiment
- 1 Hydropower experiment
- 1 FLOW-house
- Additional teaching materials
- Link to downloadable exercises.



Video of one of the FLOW-experiments



Productontwikkeling  
Universiteit Antwerpen



flow

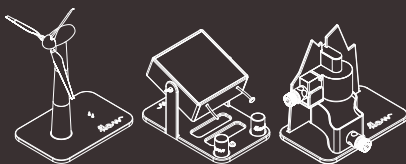

This toolkit consists of three Flow workshops, based on STEM education. The purpose of these workshops is to show alternative sources of energy, specifically solar, hydraulic and wind energy, as well as to teach the associated physics principles.

Our goal is to make pupils excited about science and implement their theoretical knowledge into a real-life context.

The toolkit has been developed during the European Project Semester in 2019, it is manufactured at the University of Antwerp. The experimental toolkit will be suitable for pupils from the 4th grade ASO in Flanders, Belgium.



flow



## Windmill

The Windmill experiment has two types of blades that can be placed in different angle configurations. A fan powers the windmill and the students can measure the generated voltage.

It will help the students to understand how windmills work, and to implement the theoretical knowledge about wind energy into a real-life context.



flow

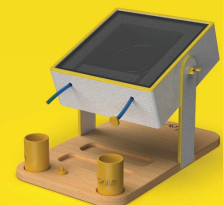

## Solar Thermal

The Solar Thermal experiment has different configurations in which the students can research the efficiency and the heat transference by measuring the temperature difference in the water.

It will help the students to understand how solar panels work, and to implement the theoretical knowledge about solar energy into a real-life context.



# APPENDIX J Video Storyboard

## Hydropower

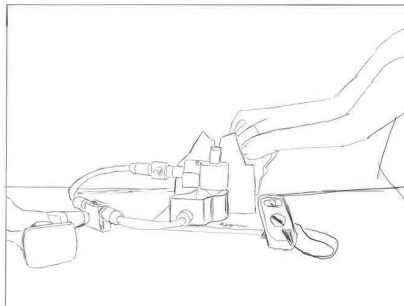
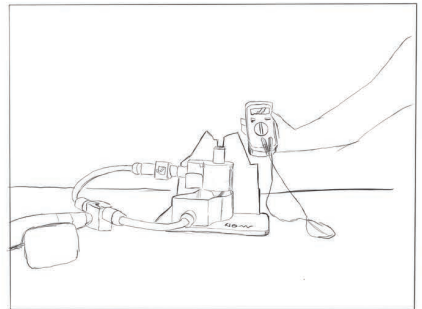
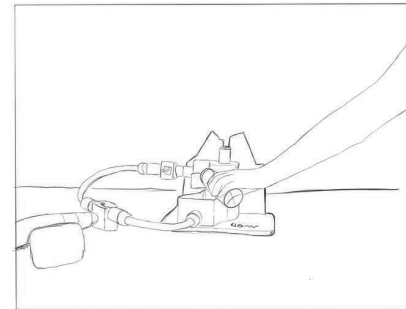
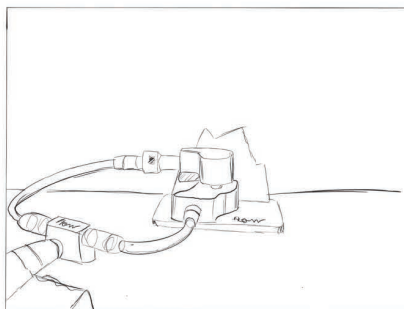
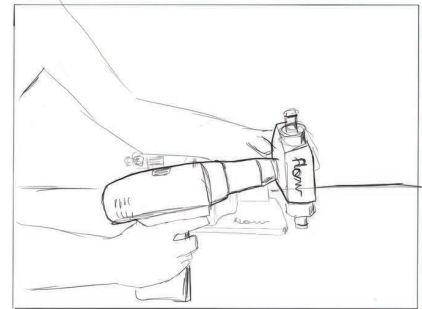
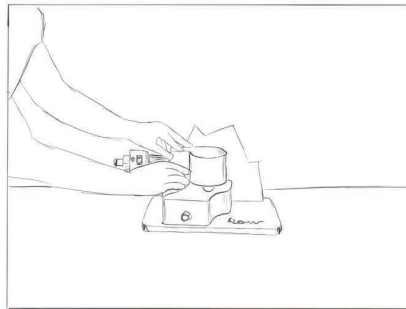
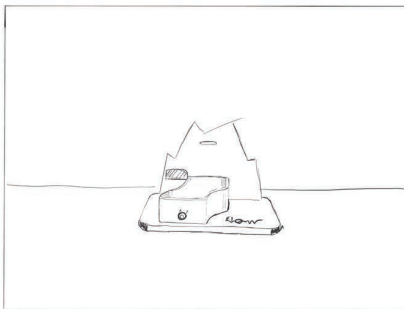
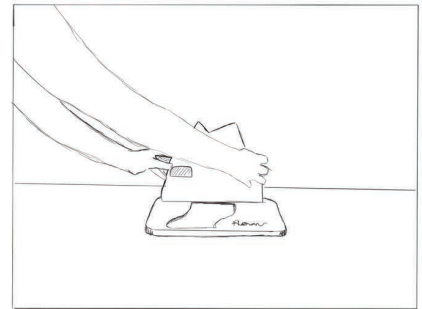
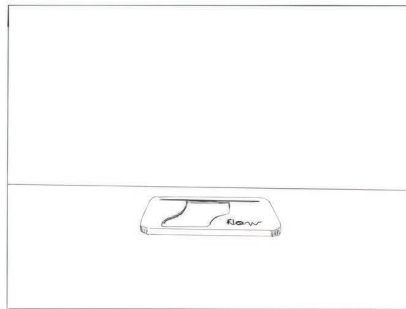
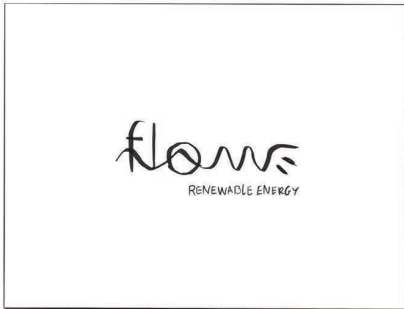

# Solar thermal

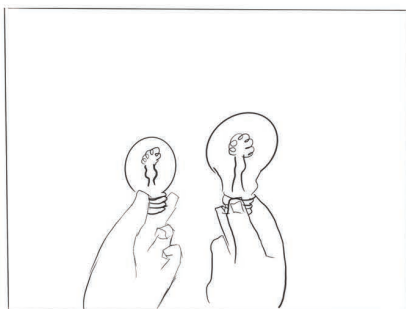
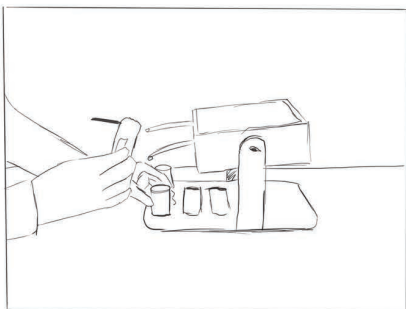
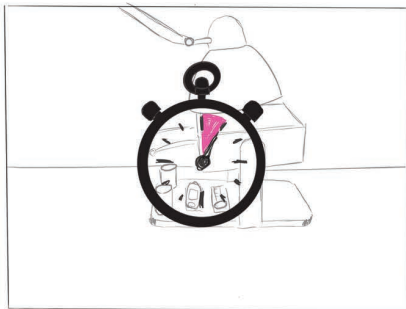
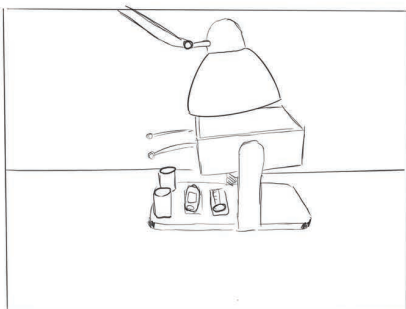
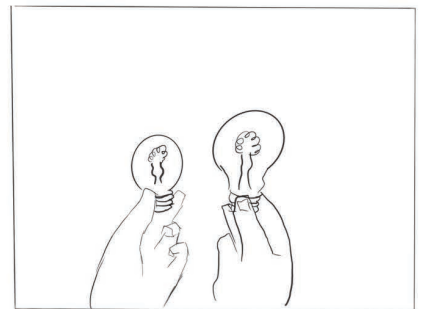
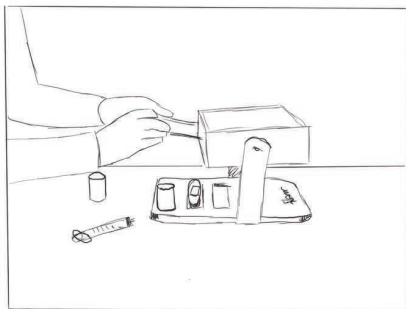
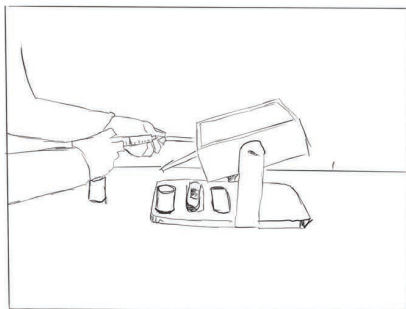
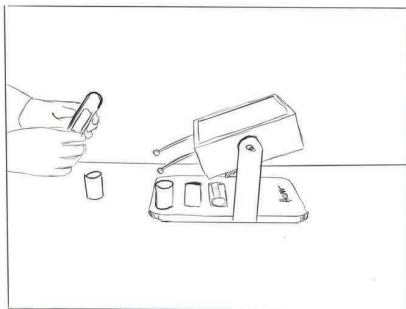
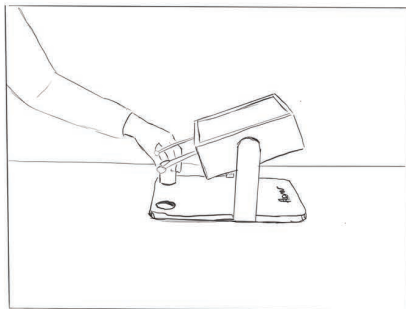
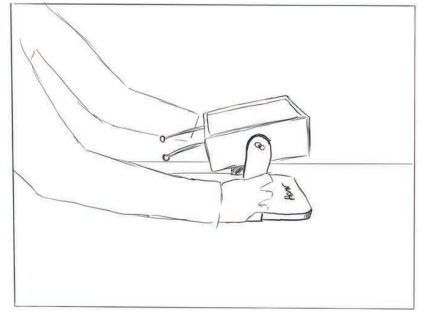
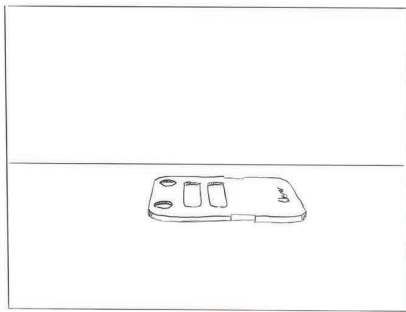
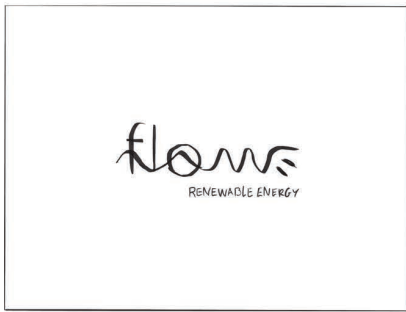

# Windmill

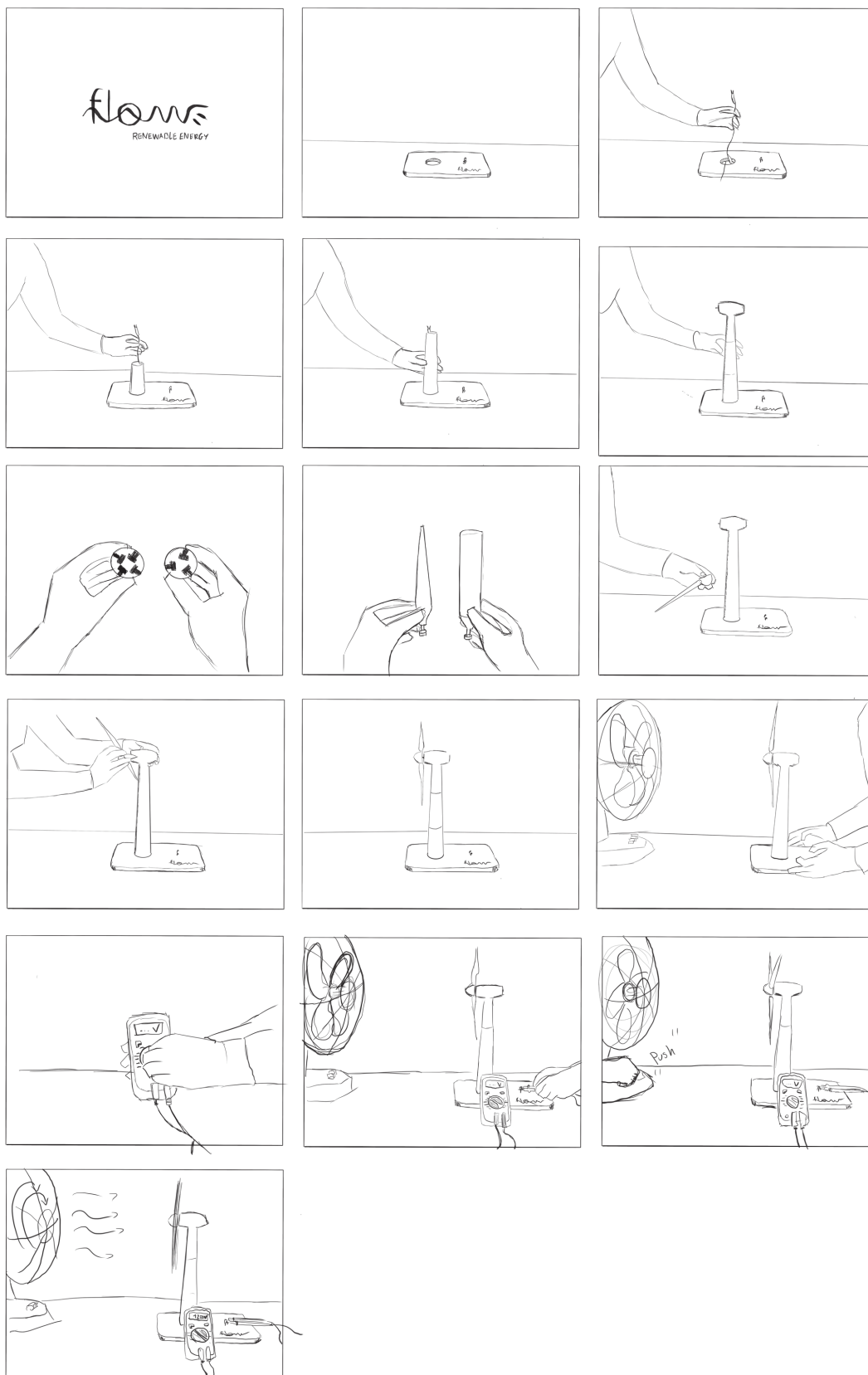

# APPENDIX K Product presentation

## Render



## Packaging



## Photos usability test





APPENDIX L  
Technical drawings  
Windmill

A-A

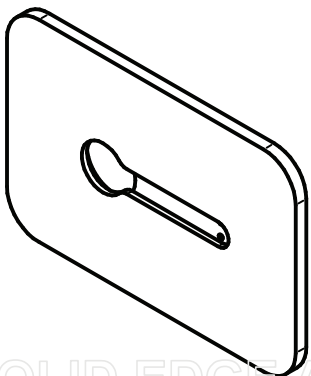
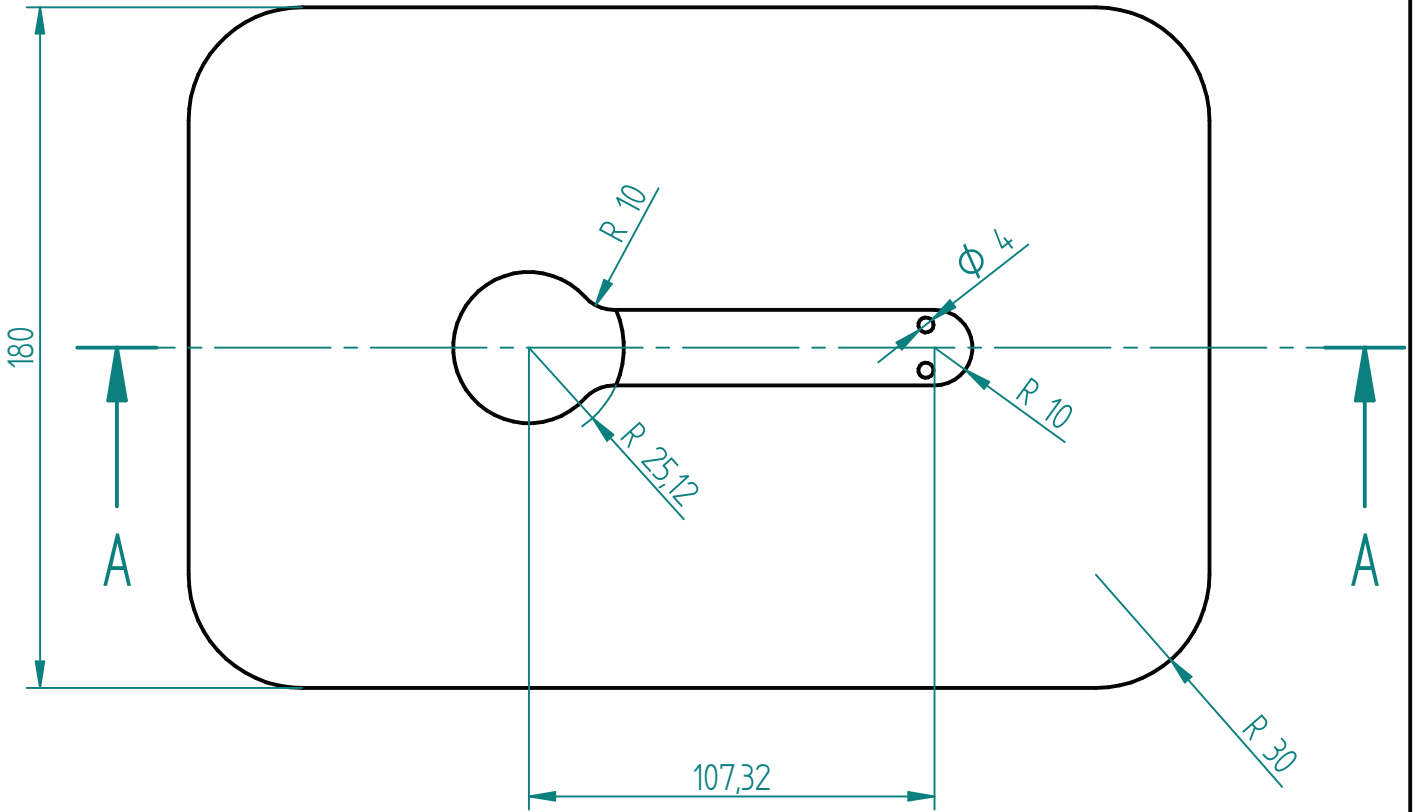
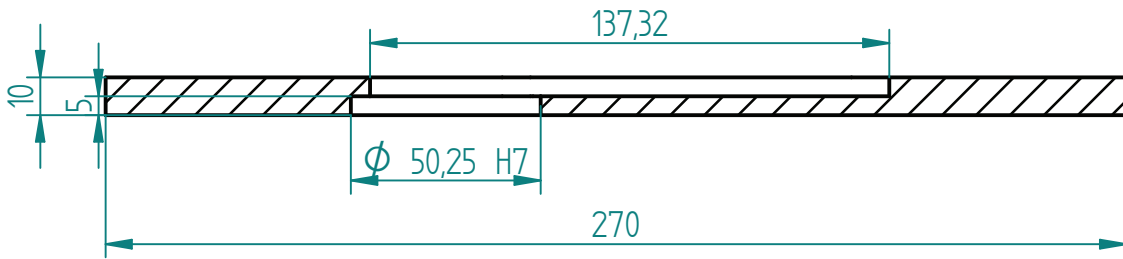

Baseplate		A4
	Universiteit Antwerpen	
	1	
		1:2

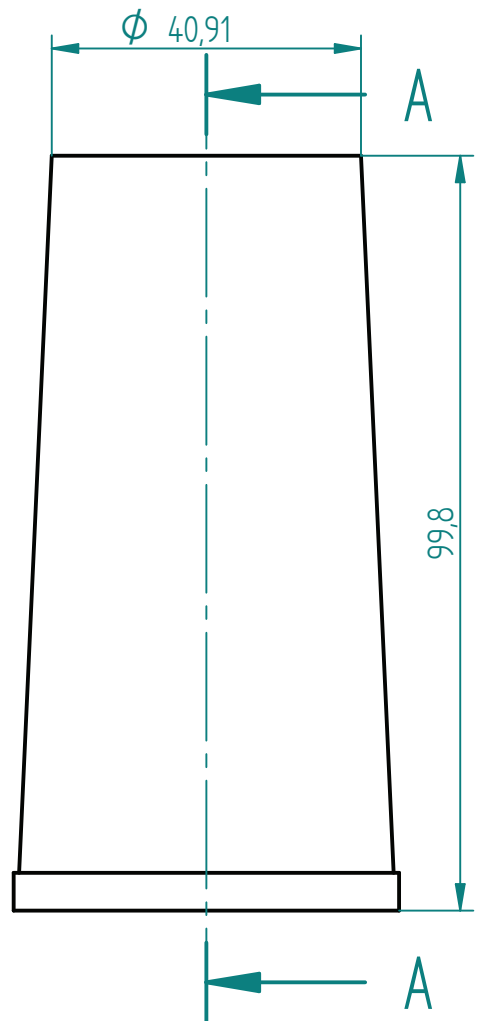
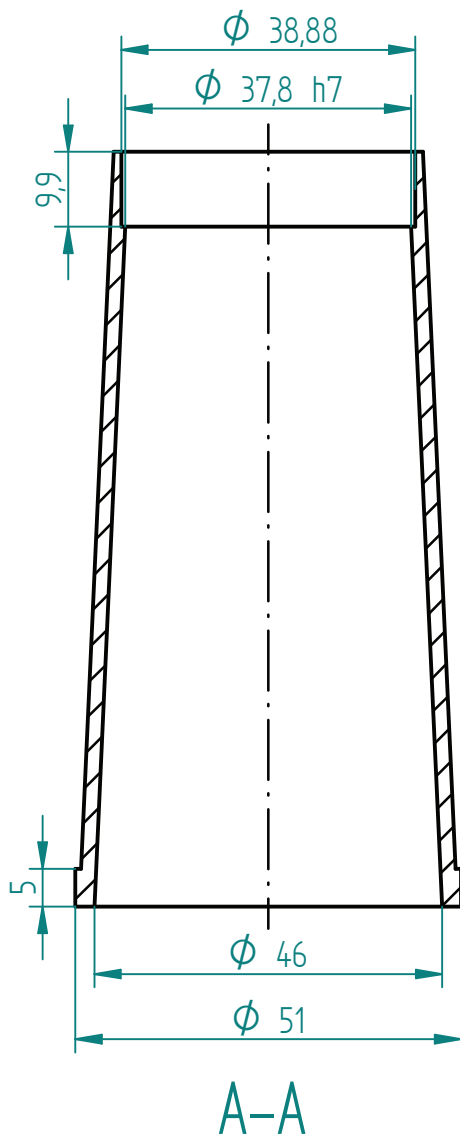
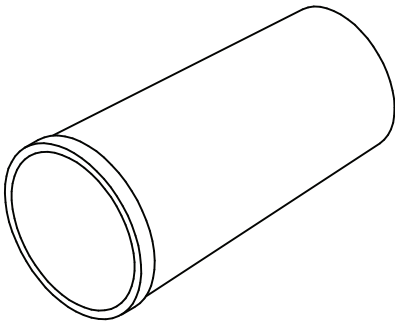

Down Tower	A4
	2
	1:1

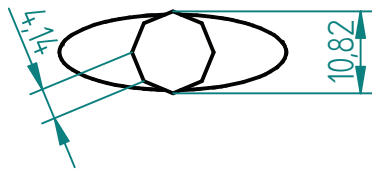
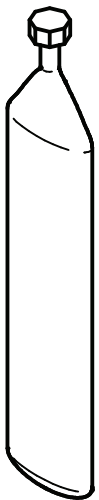
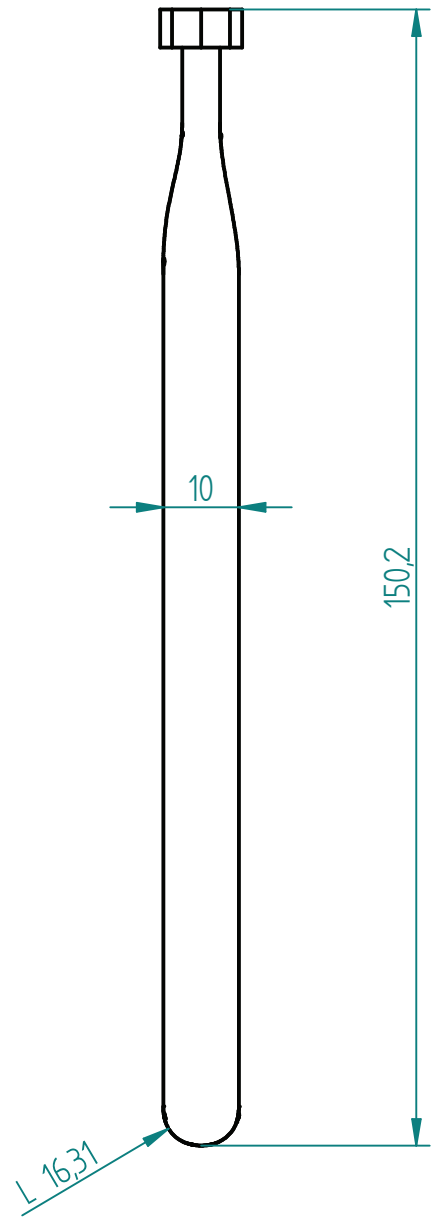
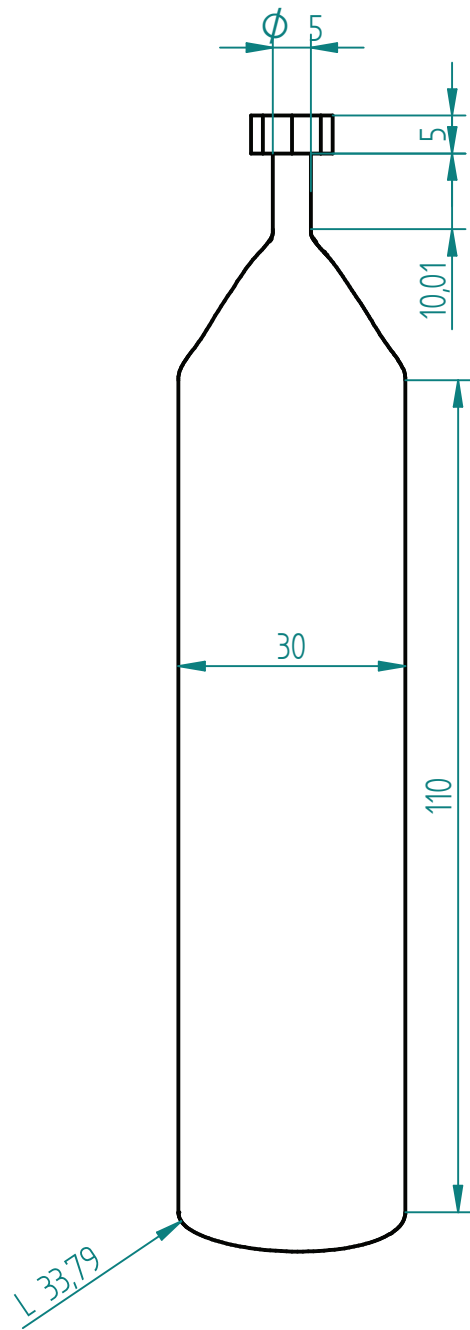

Flat wing	A4
	9
	1:1

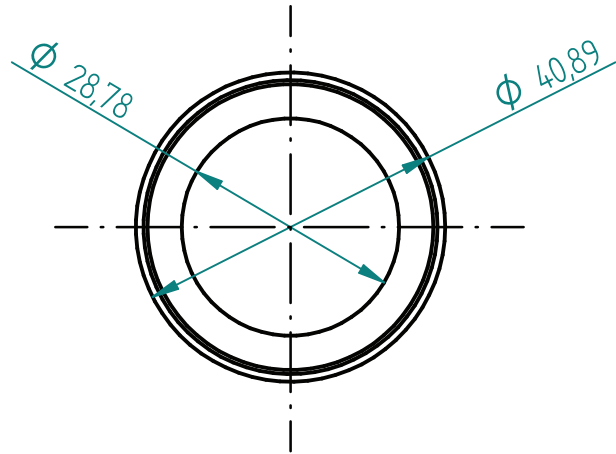
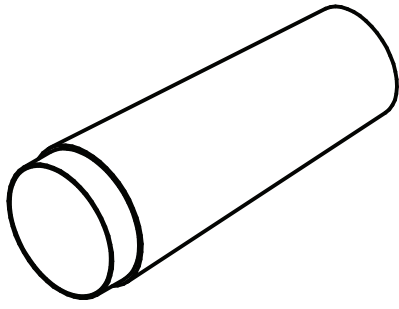

A-A

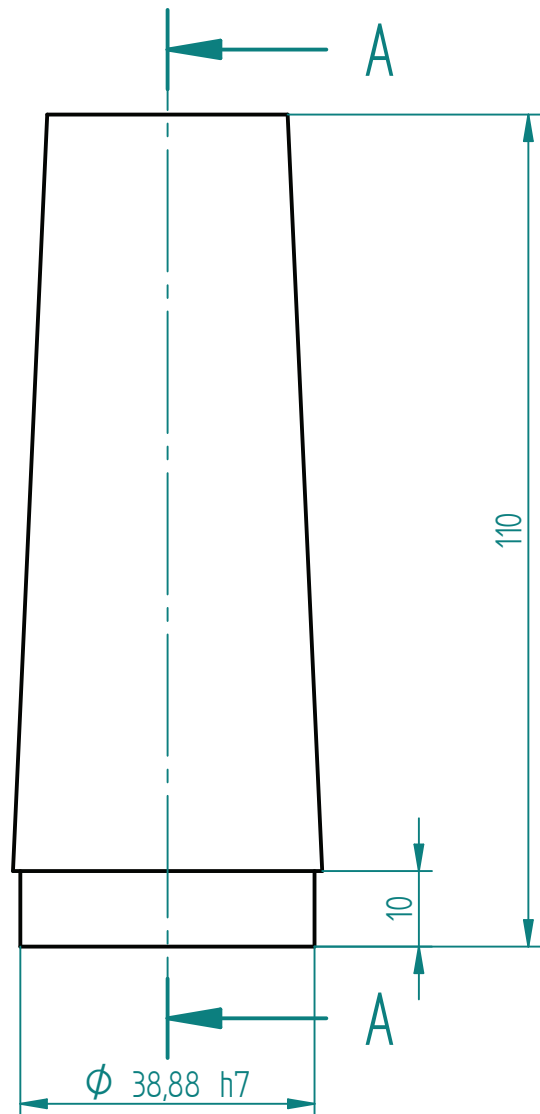
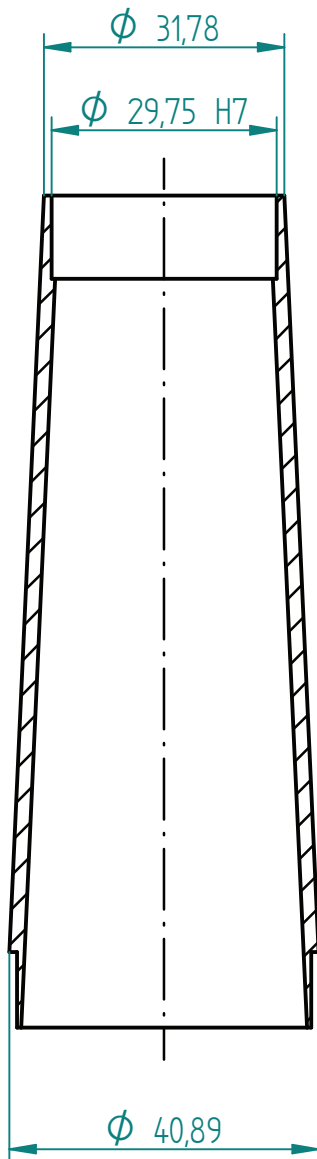

Mid Tower	A4
	3
	1:1

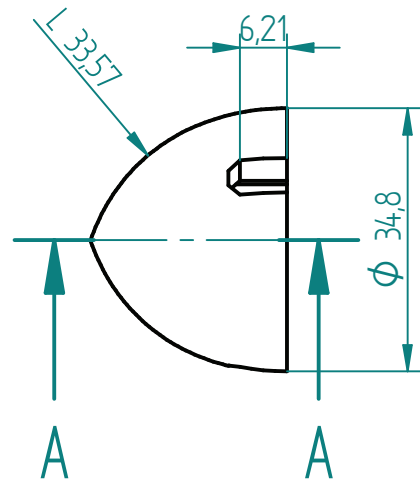
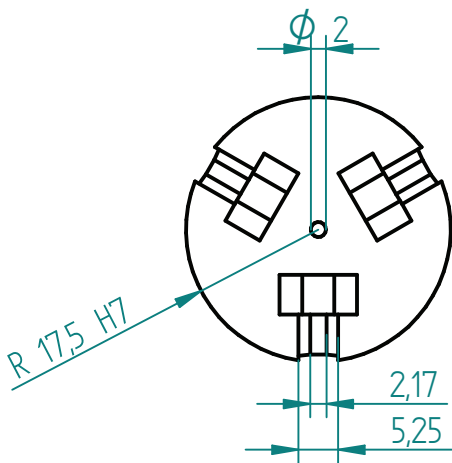
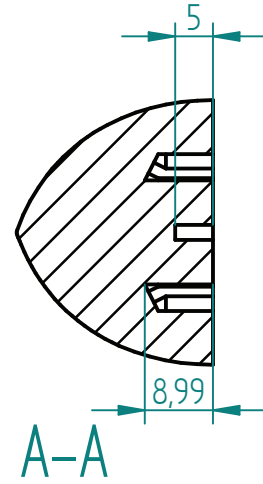
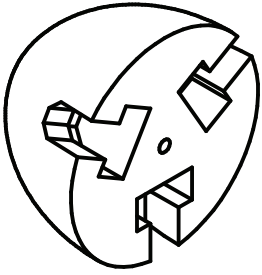

Hub 3	A4
	
8	
1:1	

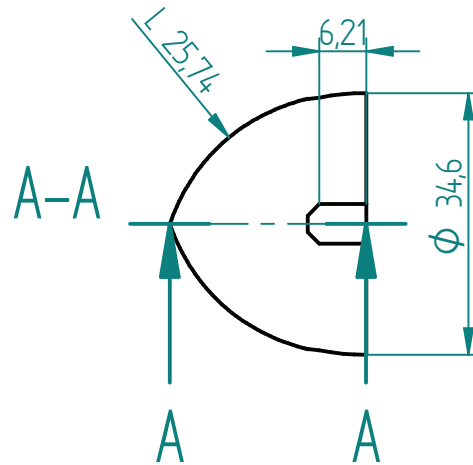
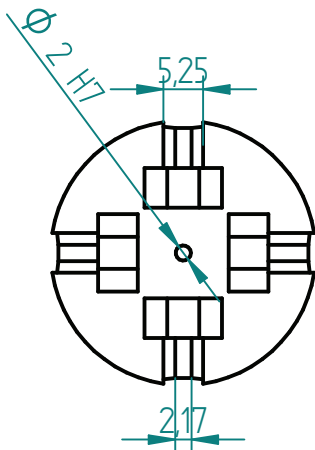
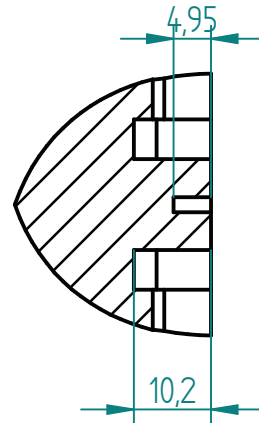
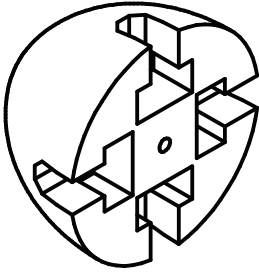

Hub	A4
	
7	
1:1	

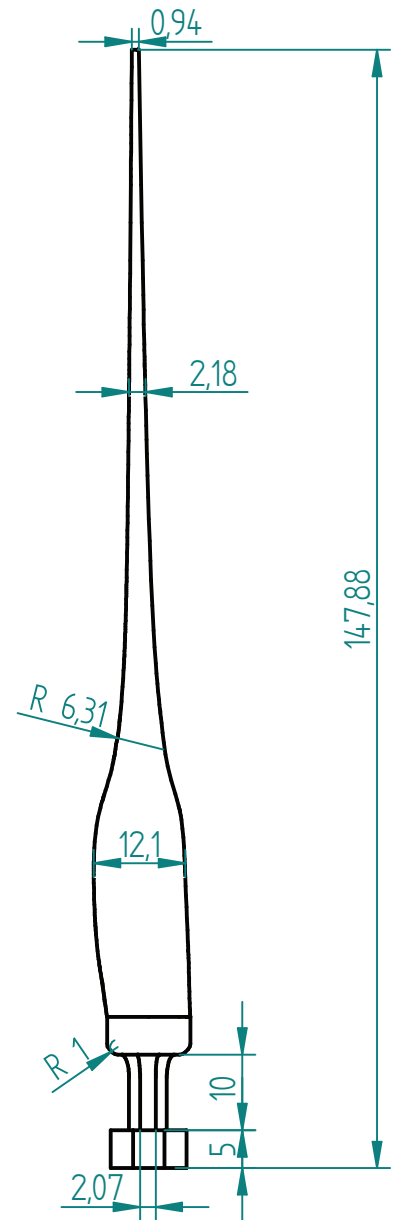
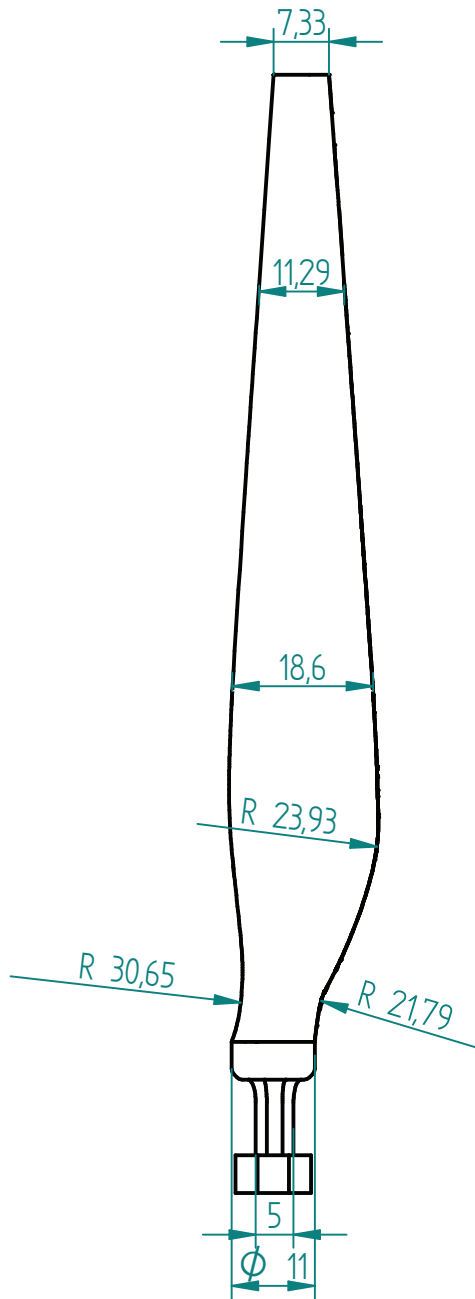
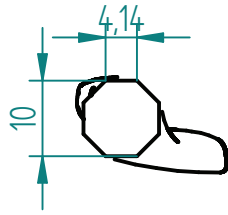

Wing		A4
		6
		1:1



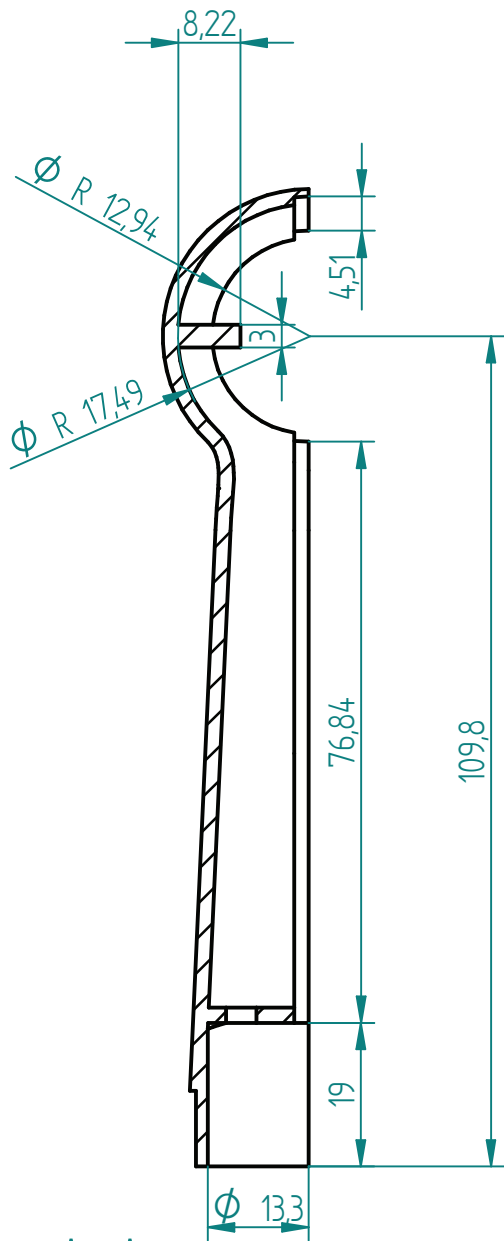

A-A

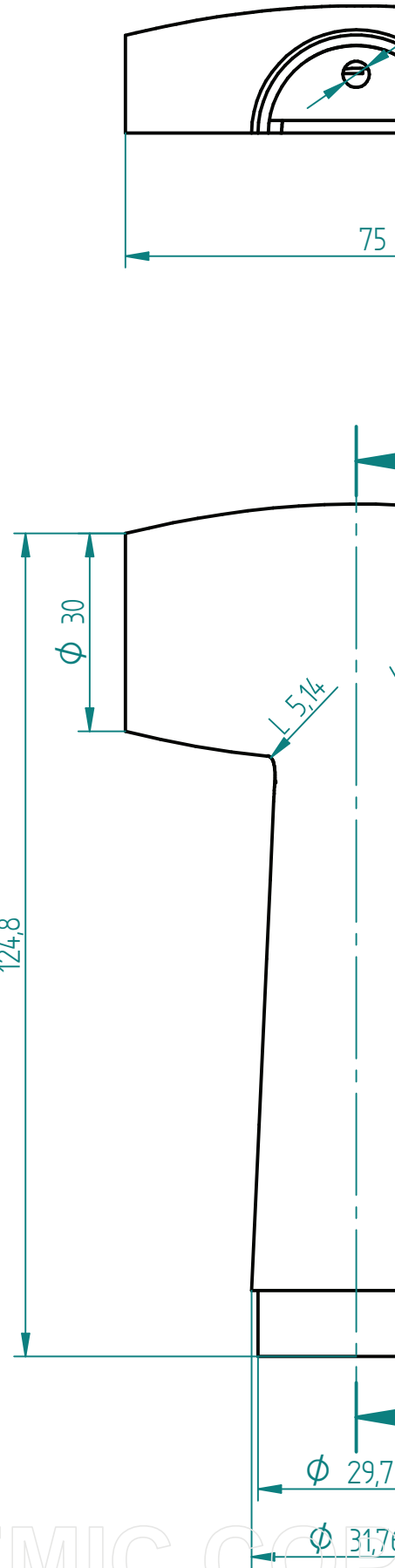

75

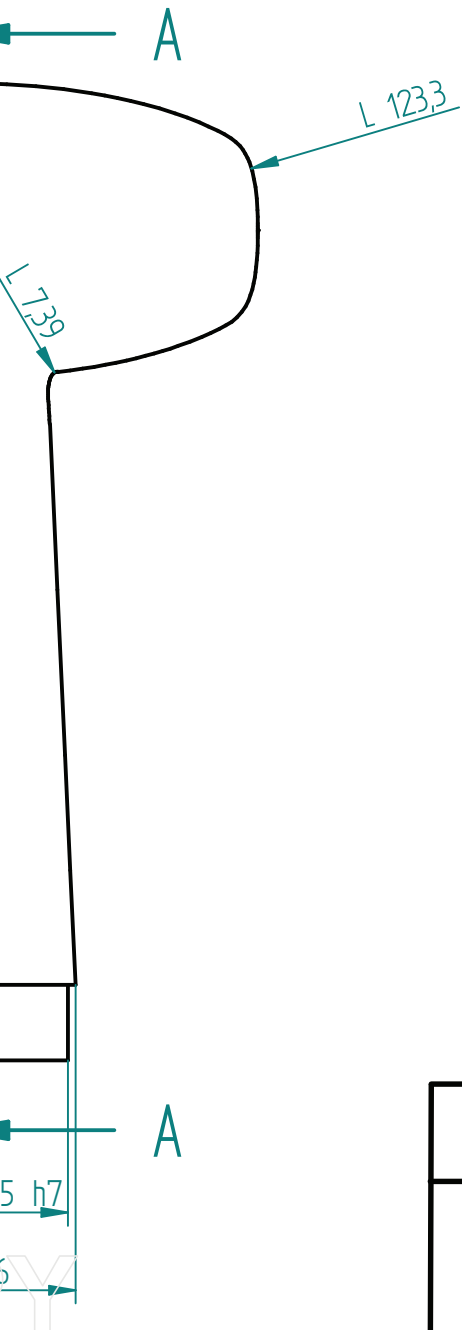
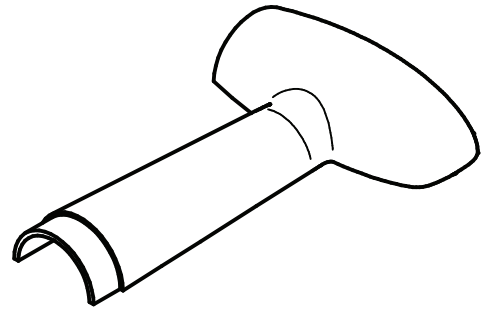
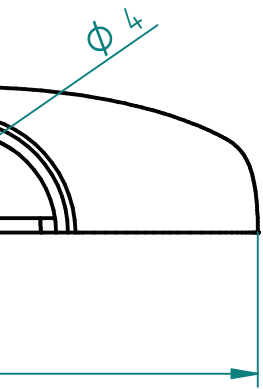

Left Shell		A3
		4
		1:1

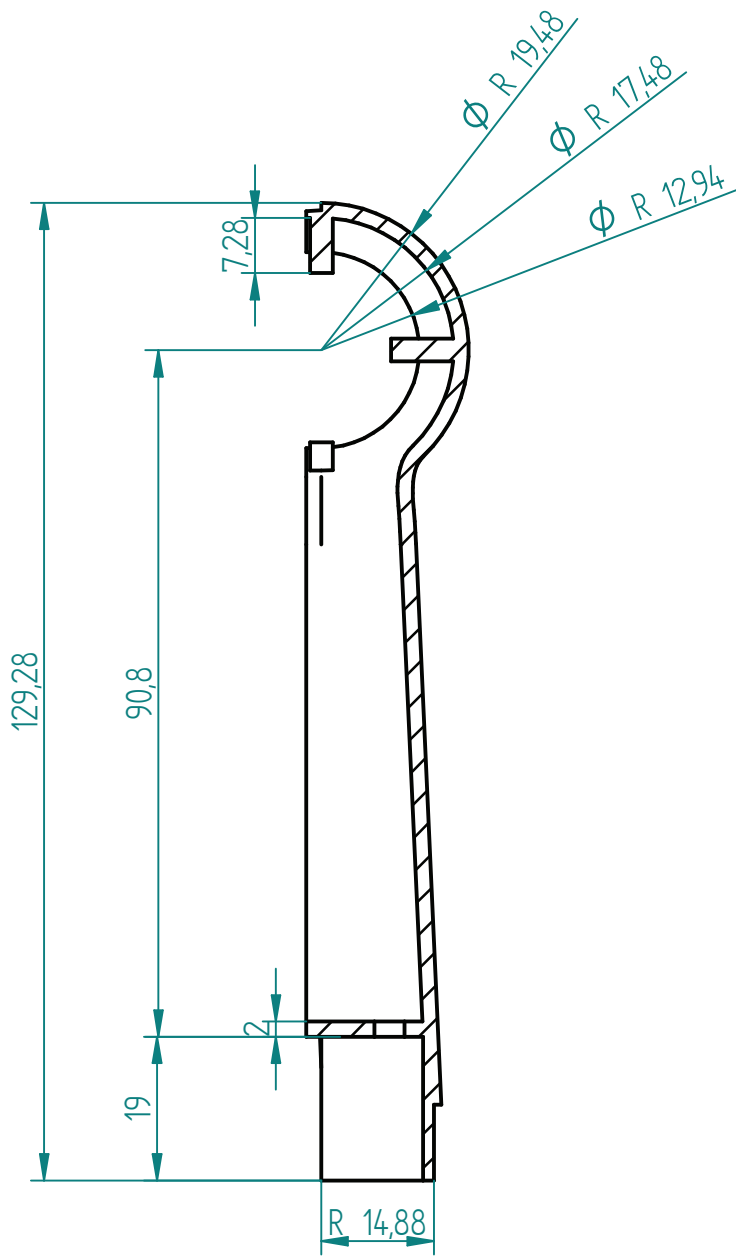

A-A

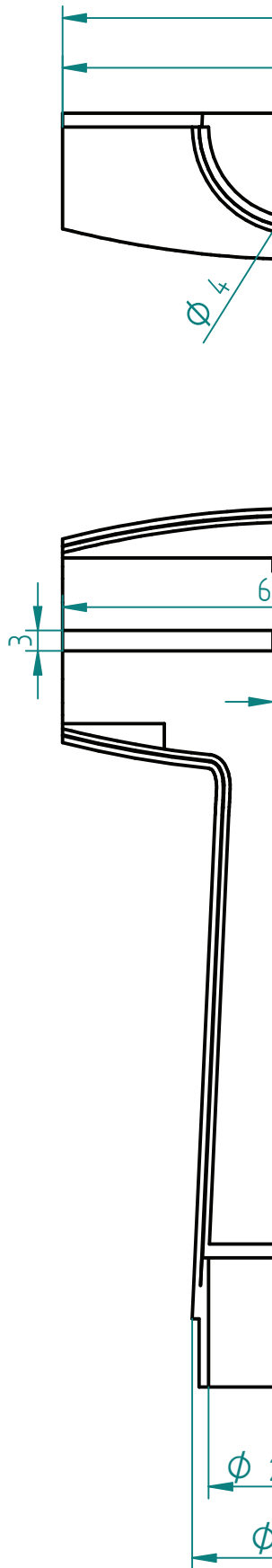

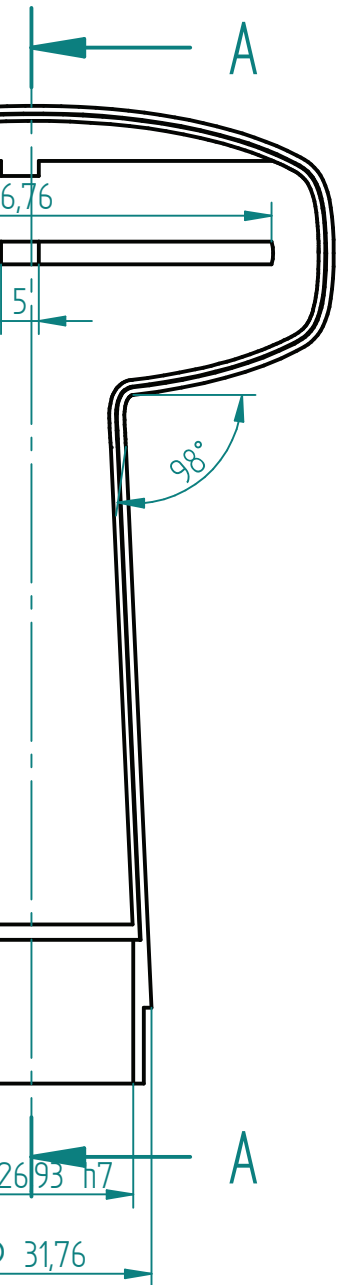
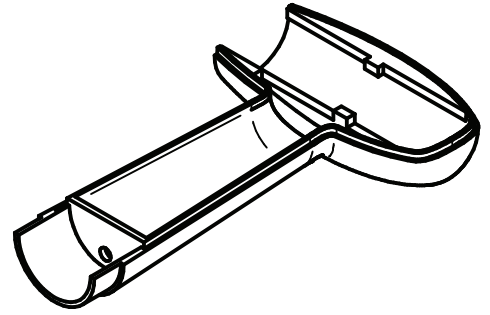
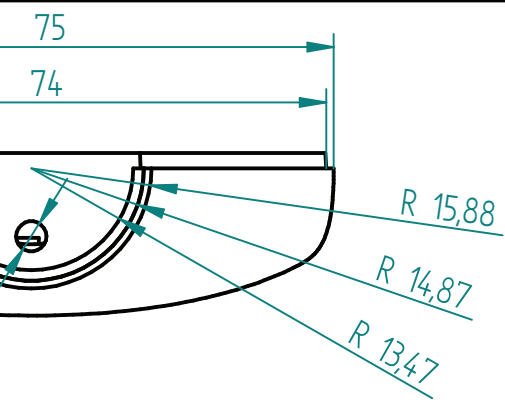

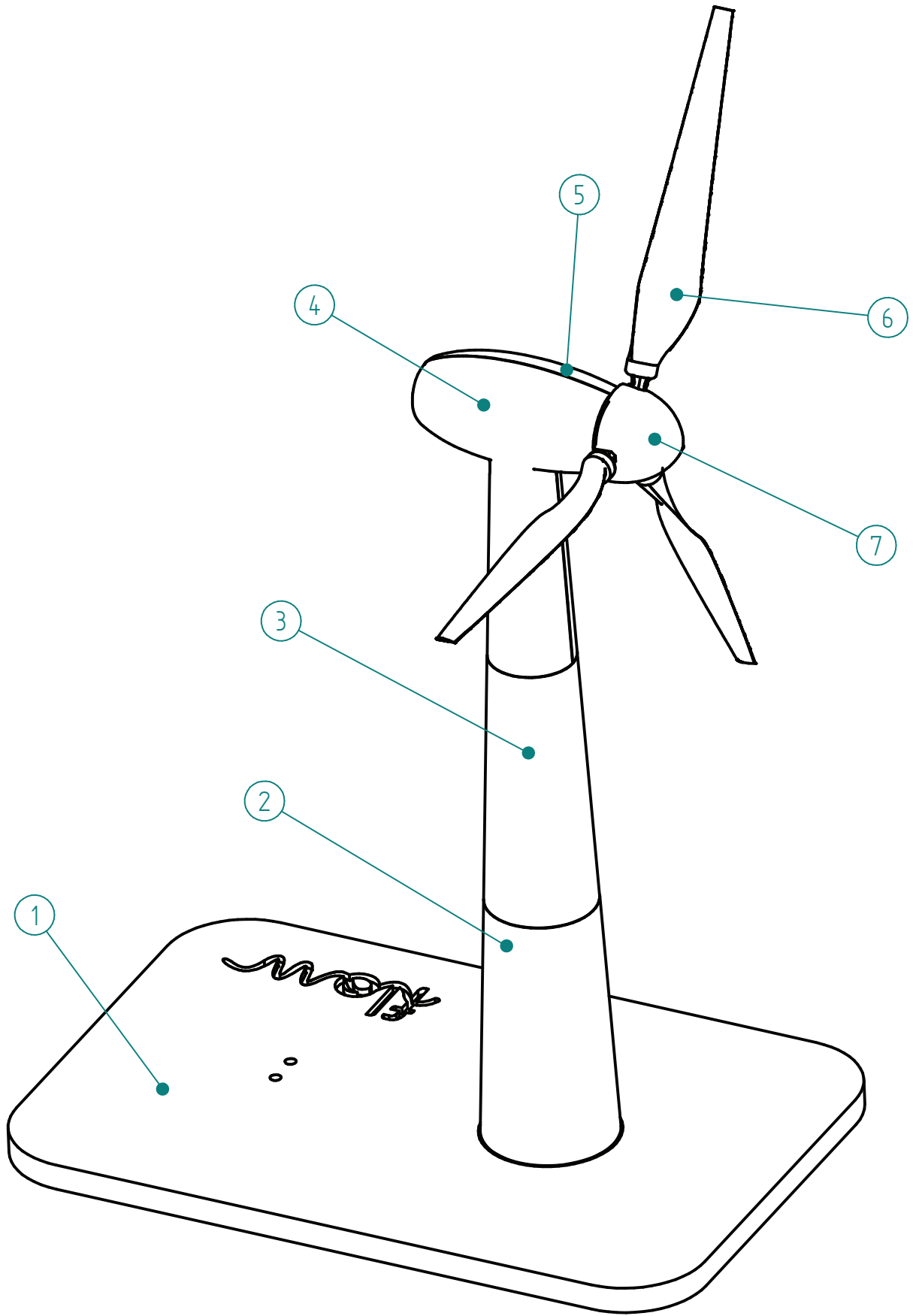

Down Tower		A3
		5
		1:1

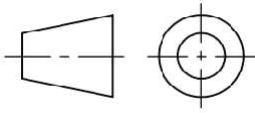

SOLID EDGE ACADEMIC COP

7	Hub	1	PLA	
6	Wing	3	PLA	
5	Right Shell	1	PLA	
4	Left Shell	1	PLA	
3	Middle Tower	1	PLA	
2	Down Tower	1	PLA	
1	Base	1	Plywood	
N°	Name	QTY	Material	Notes
Windmill				A3
		 <b>Universiteit Antwerpen</b>		

## Solar thermal

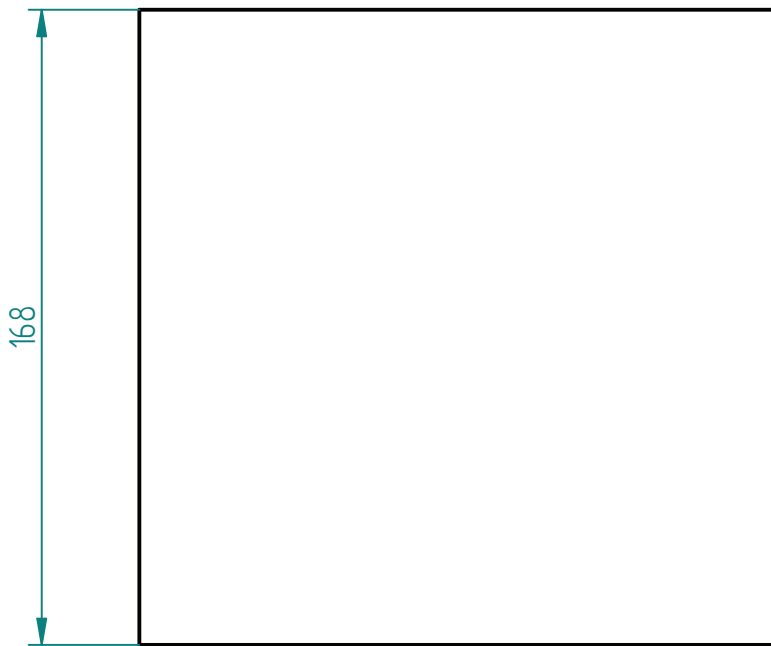
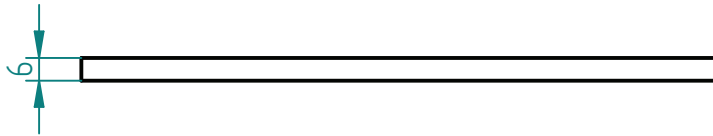
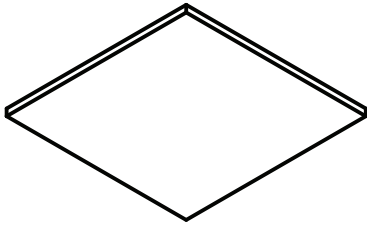

Box base	A4
	10
 Universiteit Antwerpen	1:2



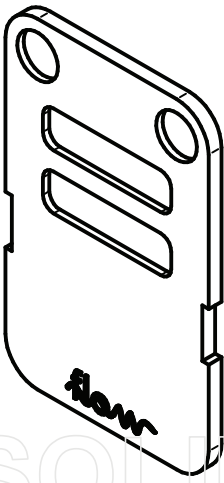
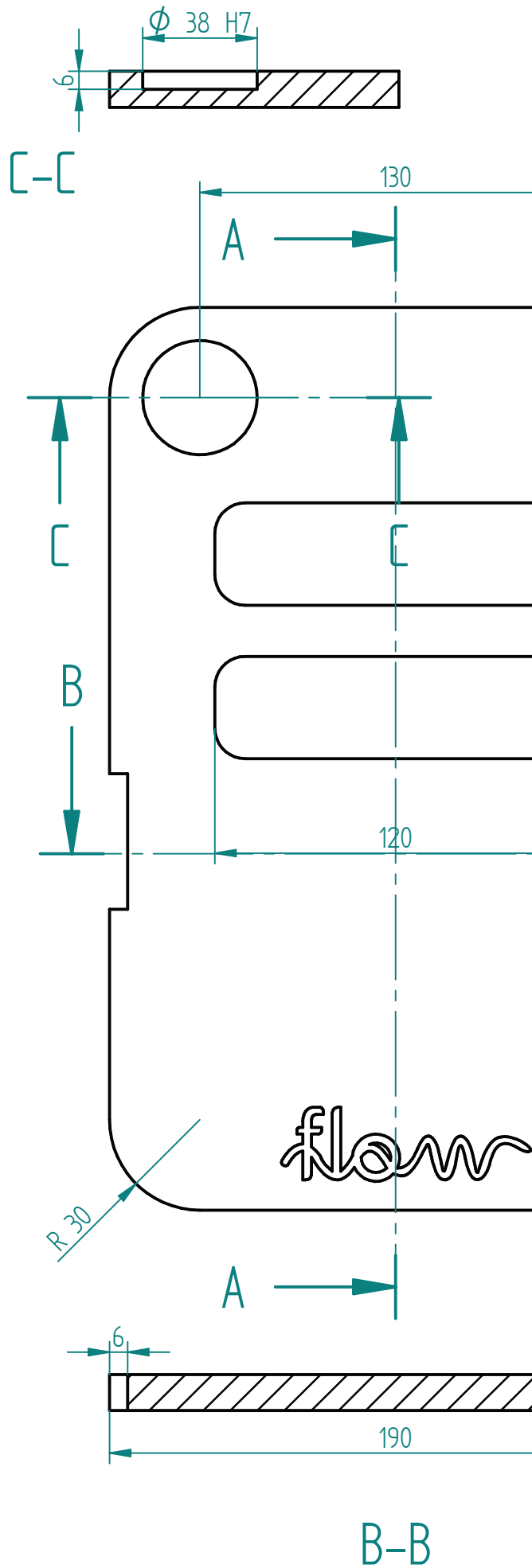

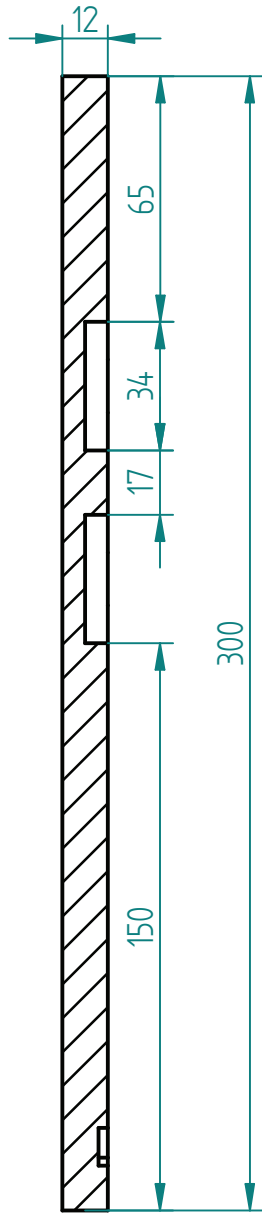
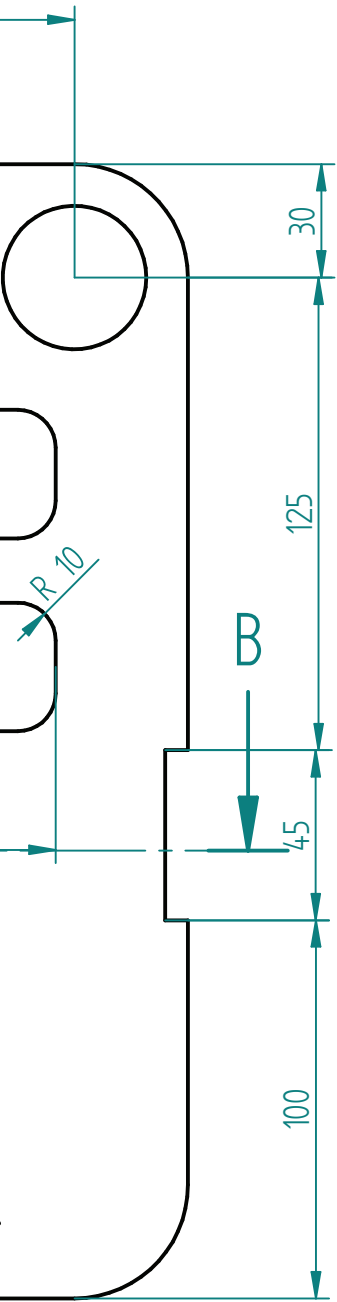

A-A

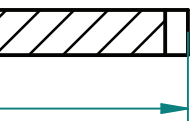

Base plate		A3
		1
		12

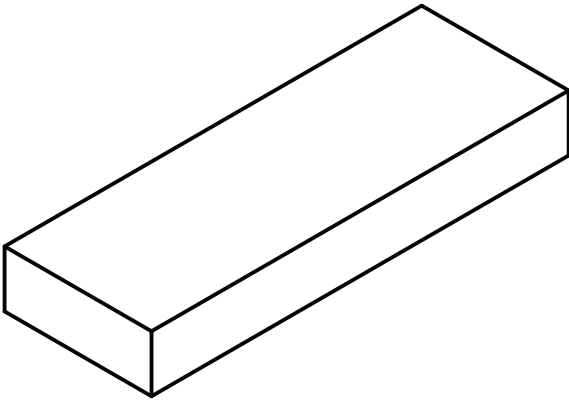

Foam 1	A4
	8
	1:1



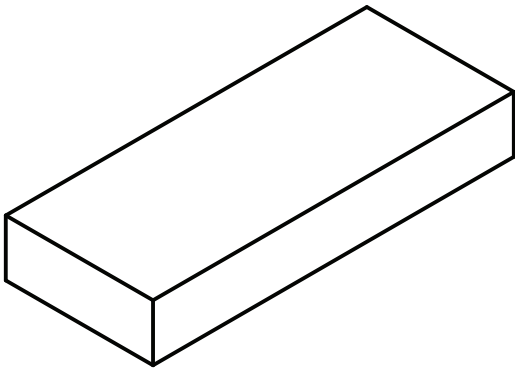

Foam 2	A4
	Universiteit Antwerpen
	1:1

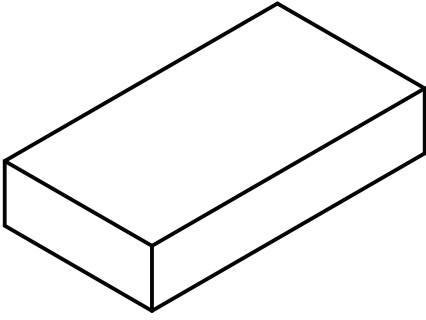

Foam 3	A4
	14
	1:1

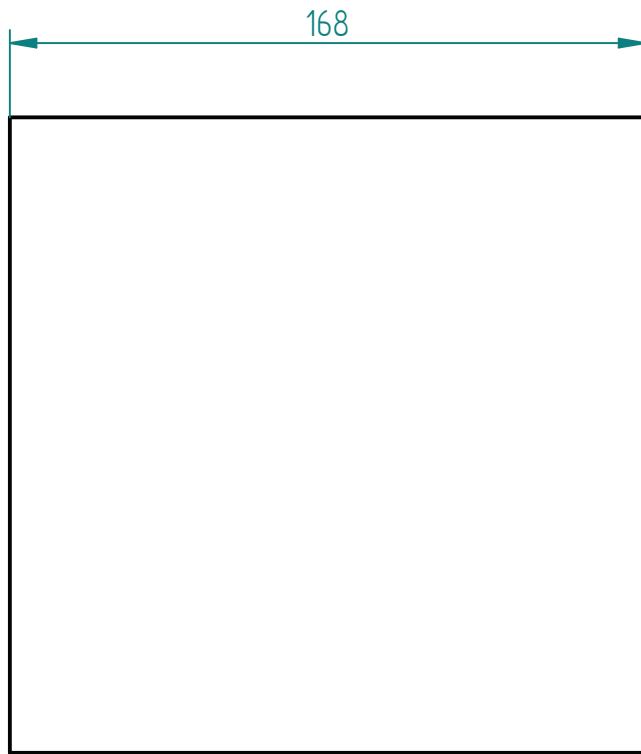
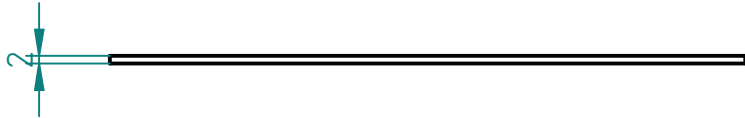
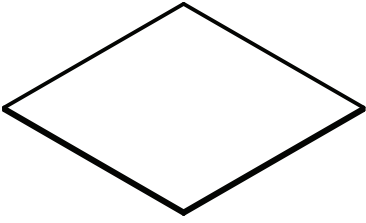

Glass	A4
	2
 Universiteit Antwerpen	1:2

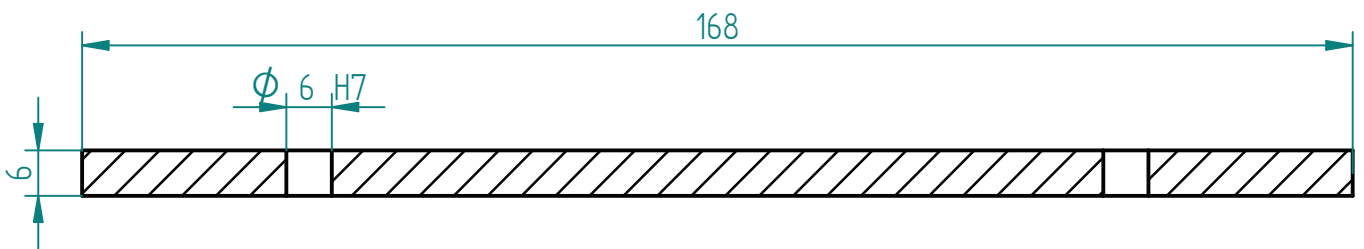
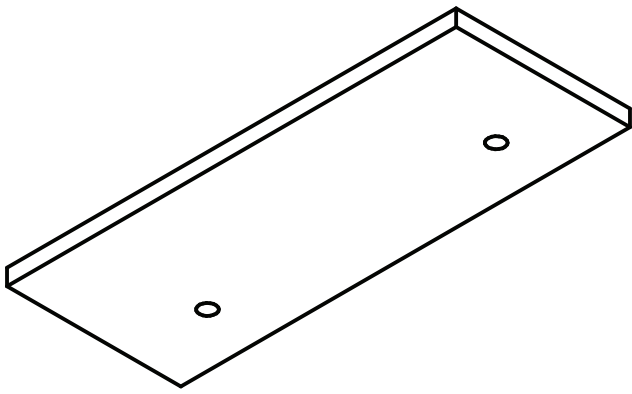

A-A

108

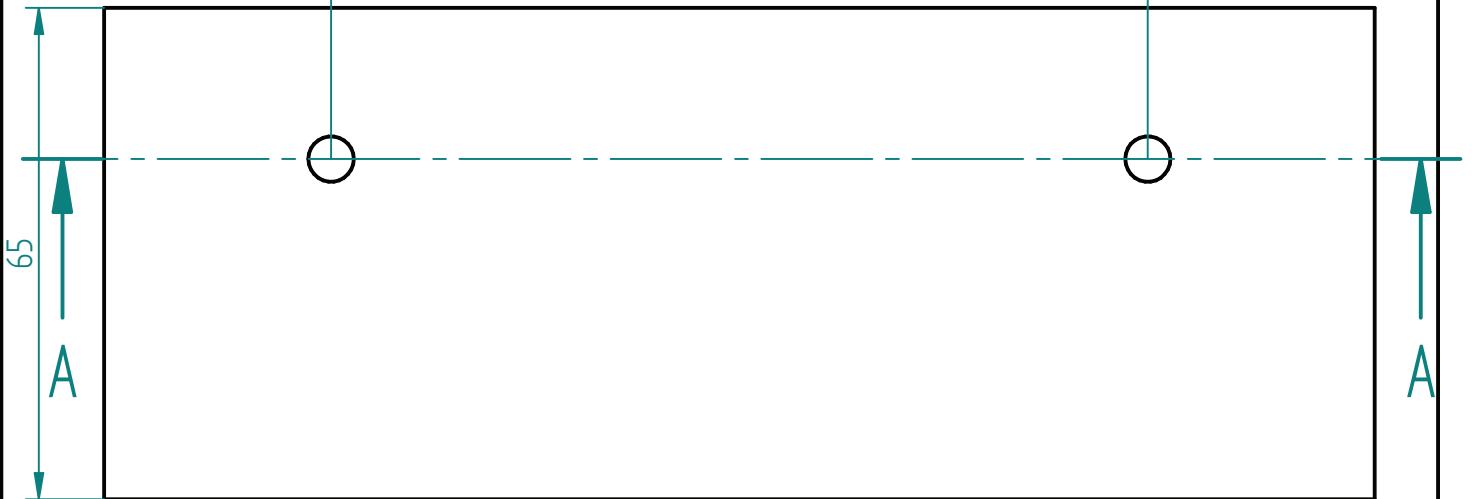

Side 1	A4
	4
 Universiteit Antwerpen	1:1

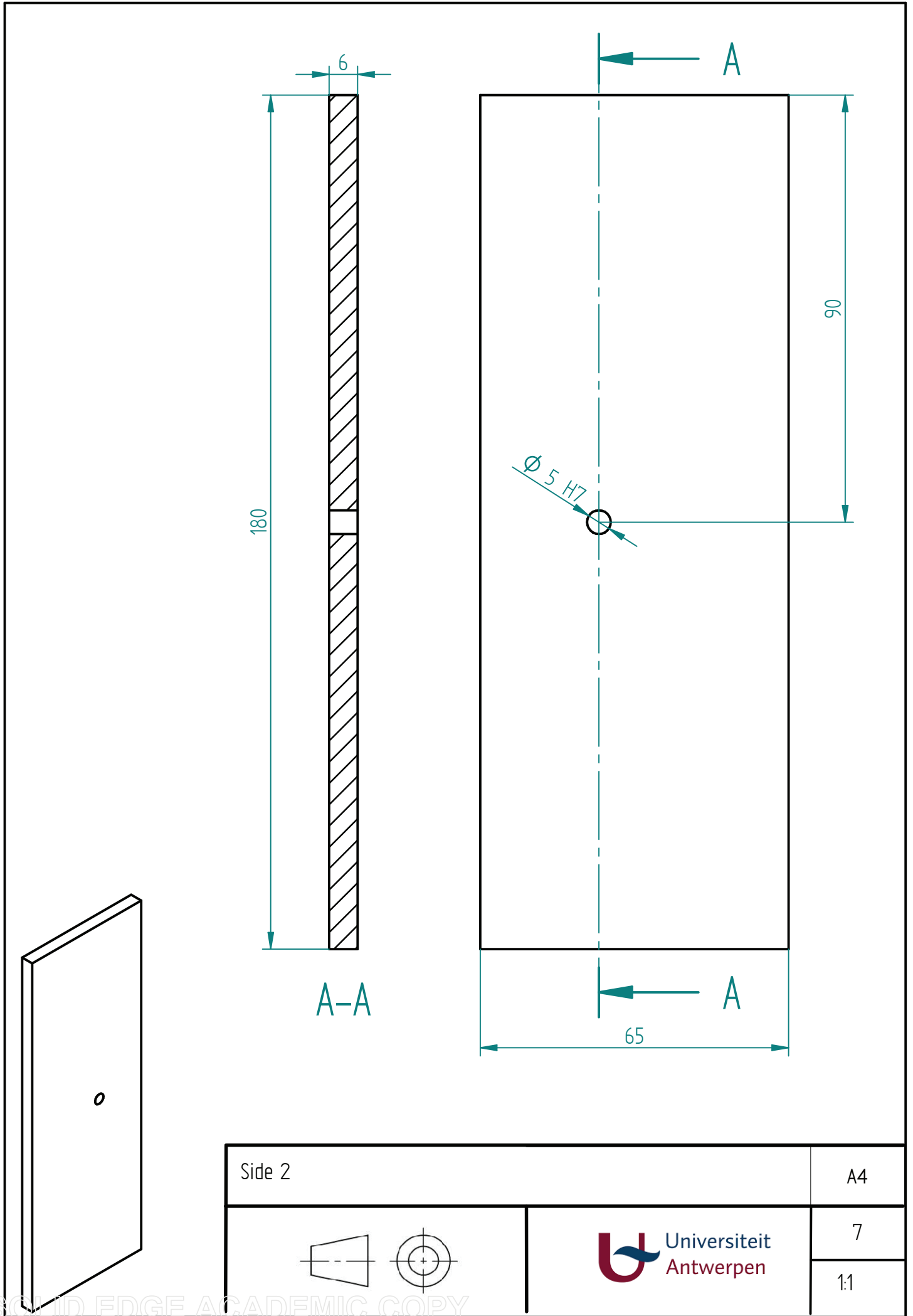

Side 2	A4
	7
	1:1



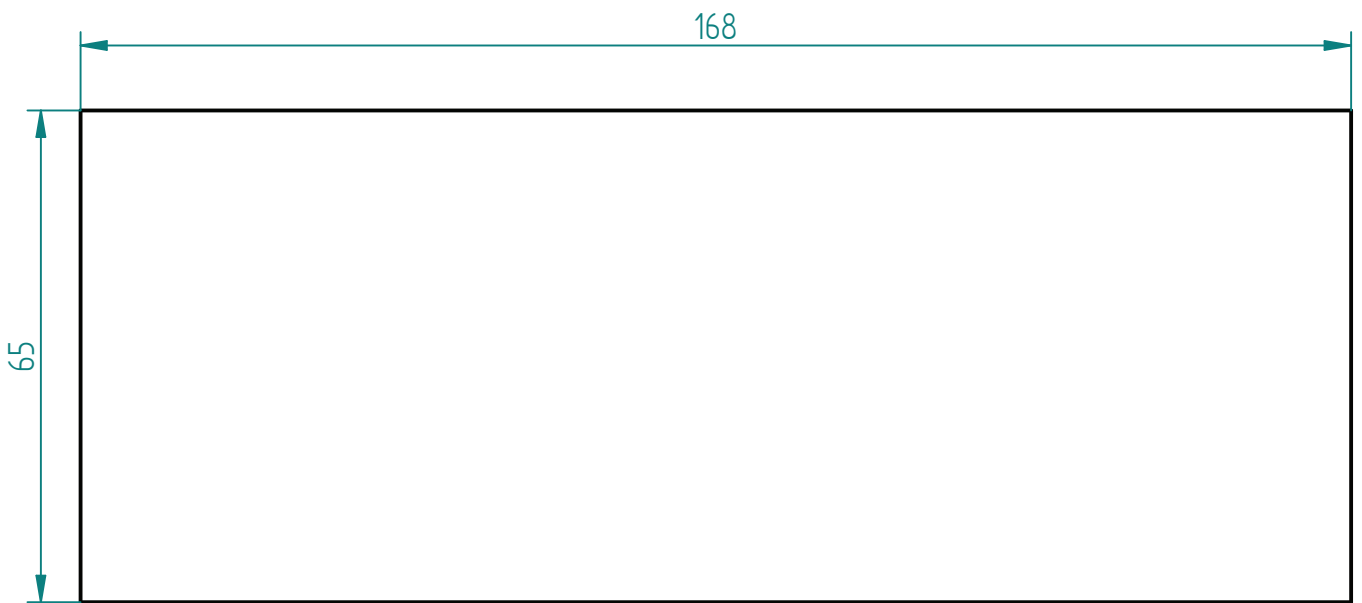
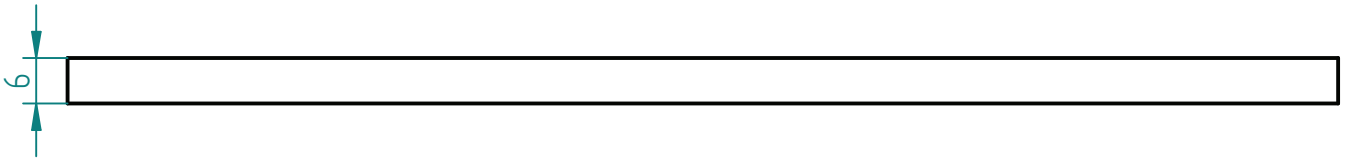
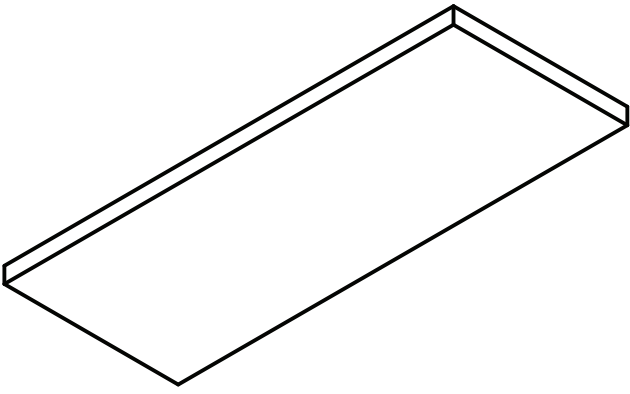

Side 3	A4
	13
 Universiteit Antwerpen	1:1

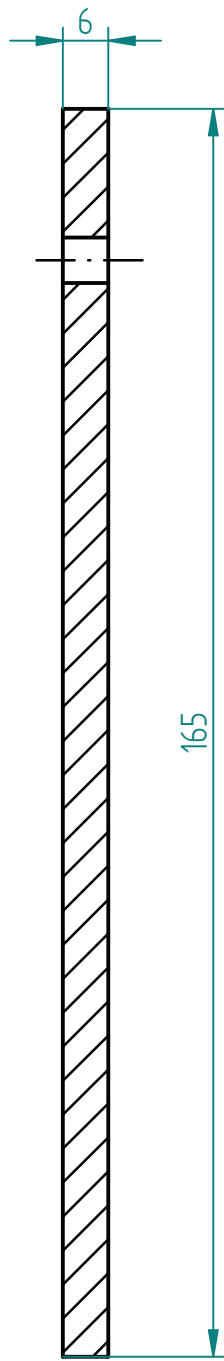
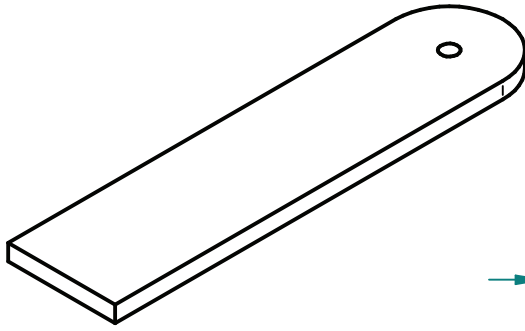

A-A

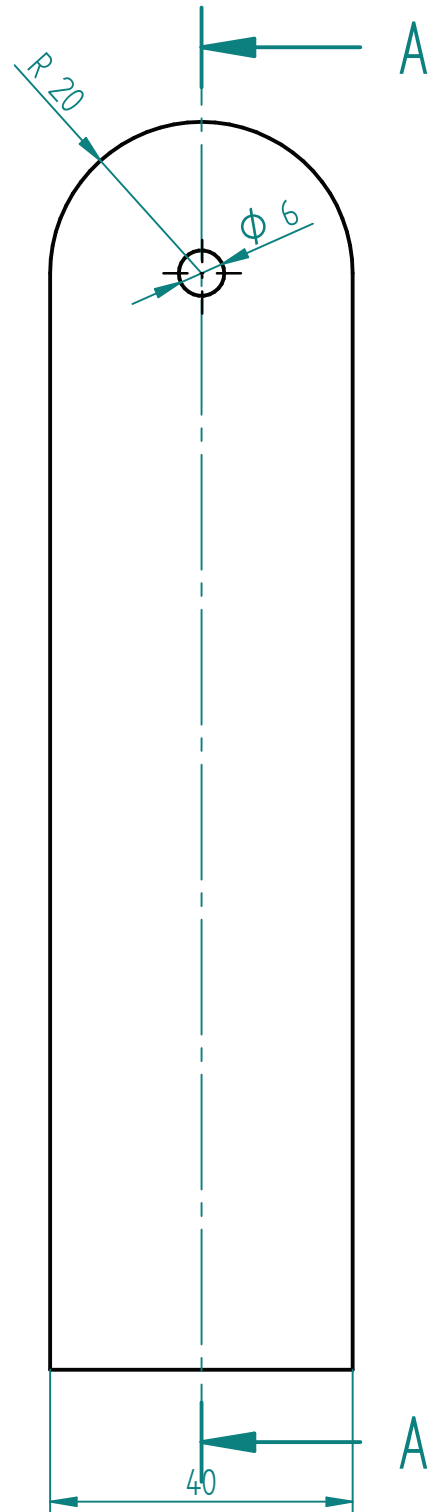

Stand	A4
	3
	1:1

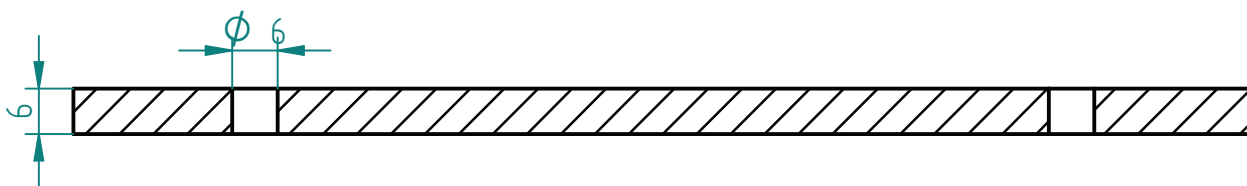
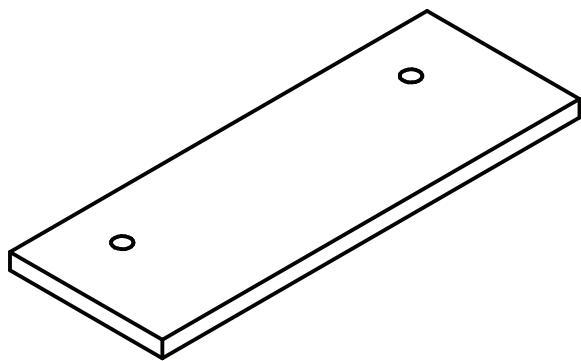

CORTE A-A

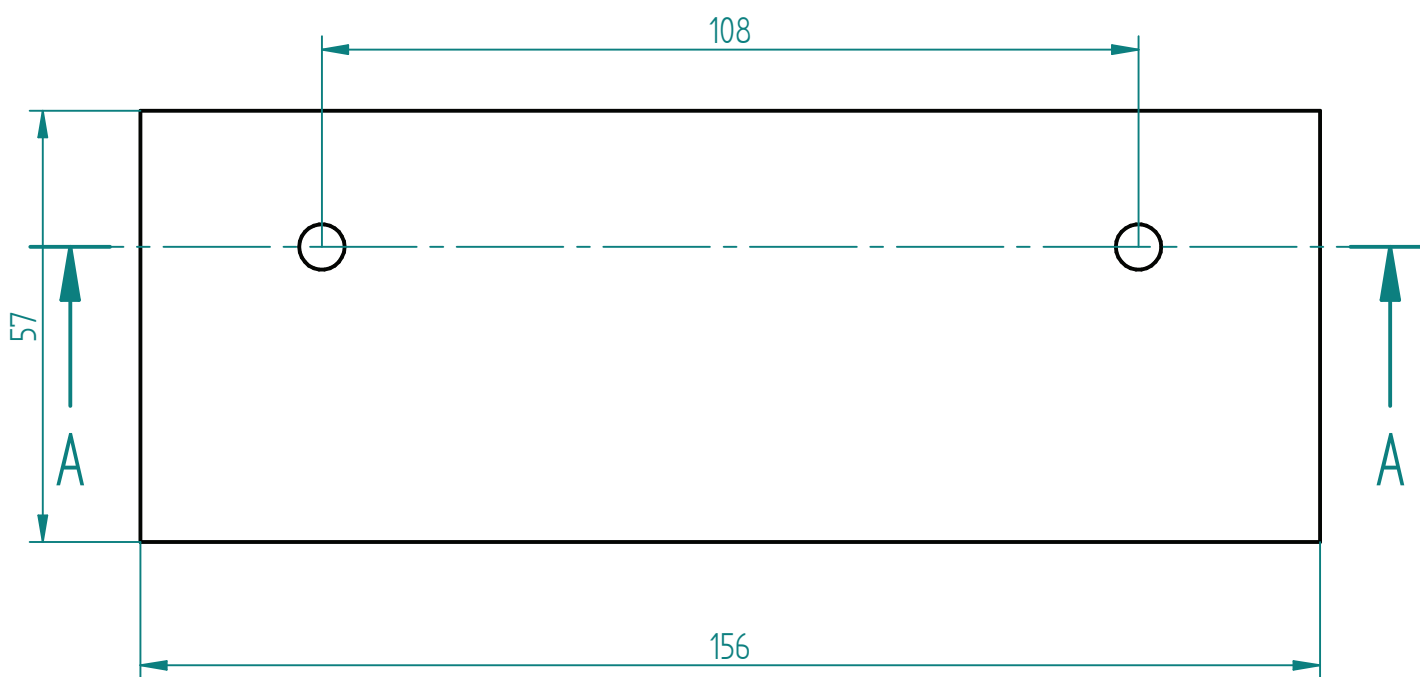

Support 1	A4
	6
	1:1

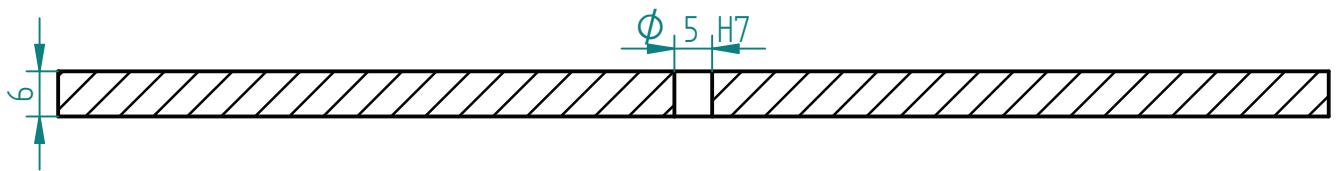
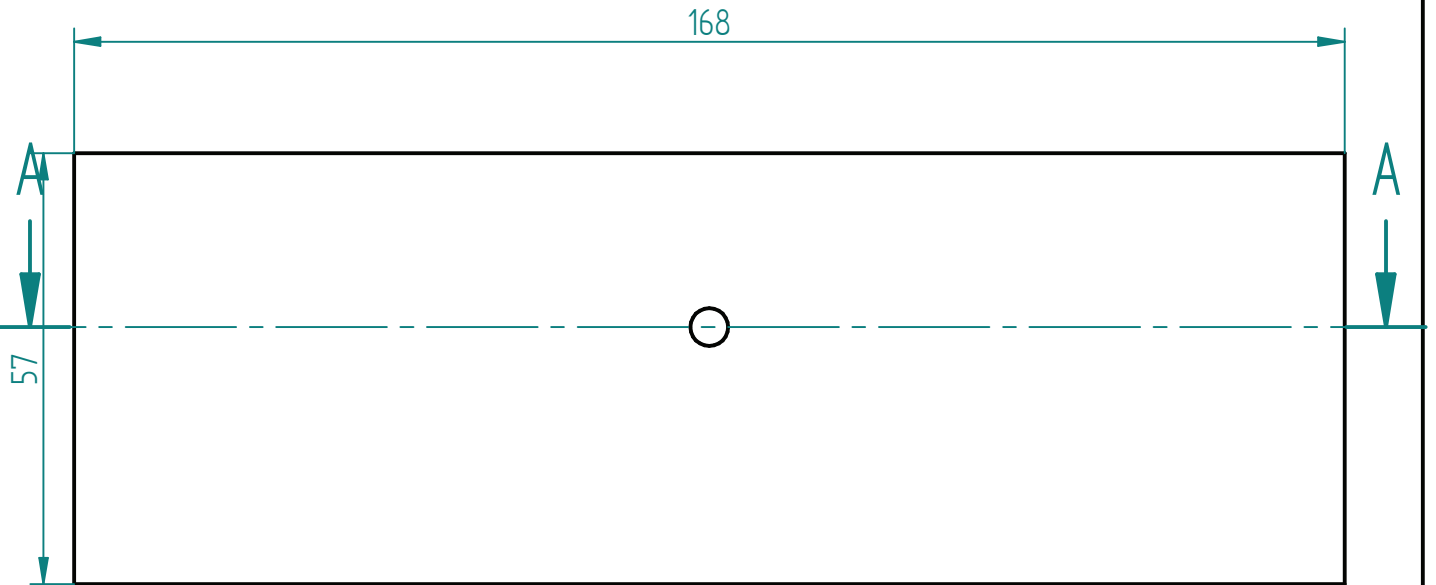
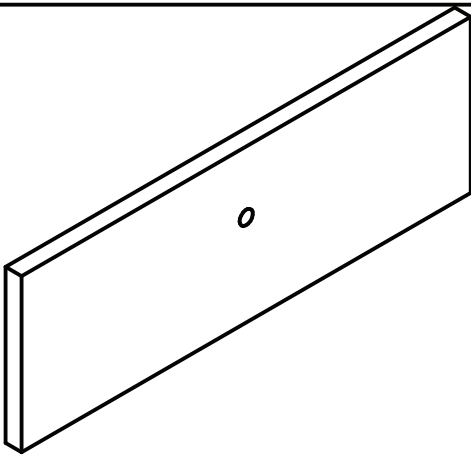

A-A

Support 2	A4
	9
	1:1

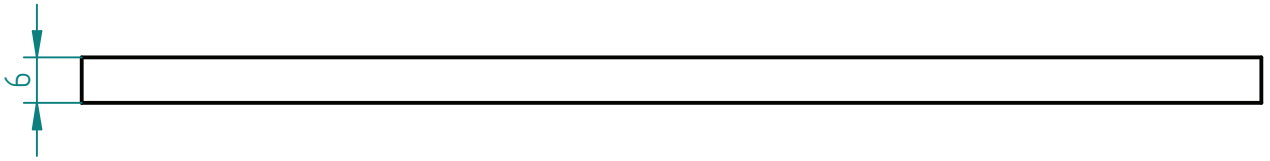
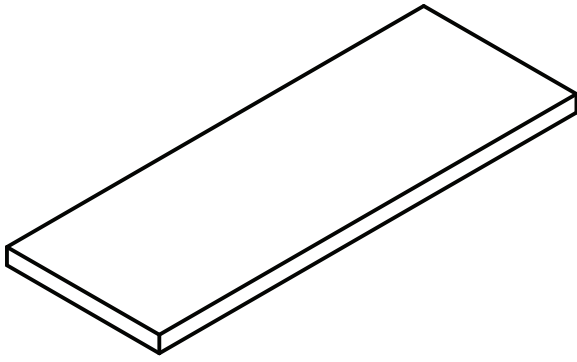

Support 3	A4
	12
	1:1

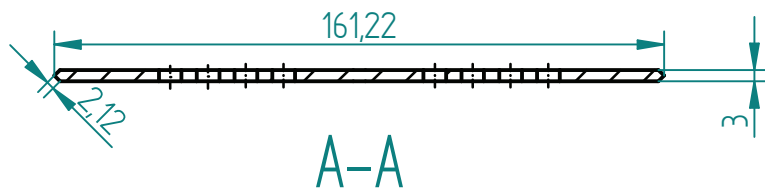
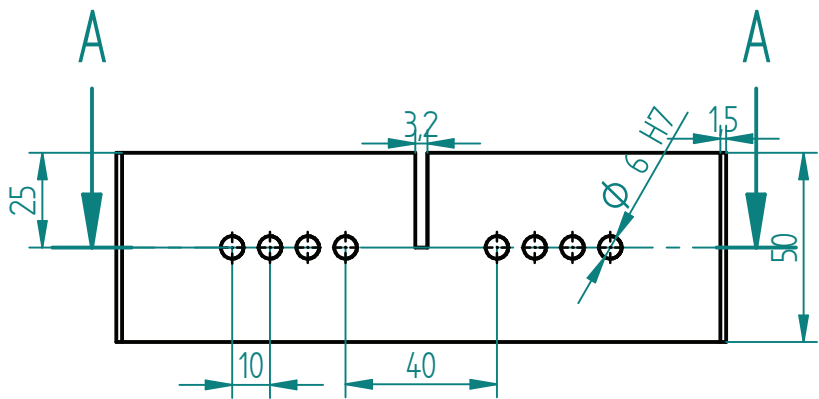
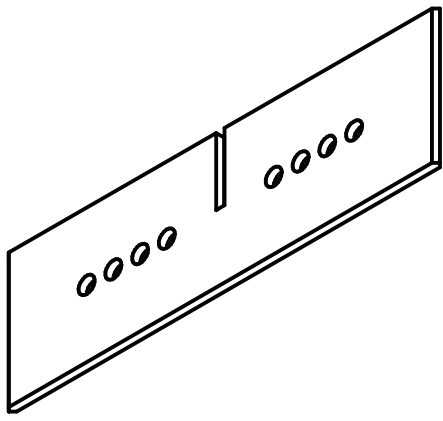

Tubes Support	A4
	 Universiteit Antwerpen 15 1:2

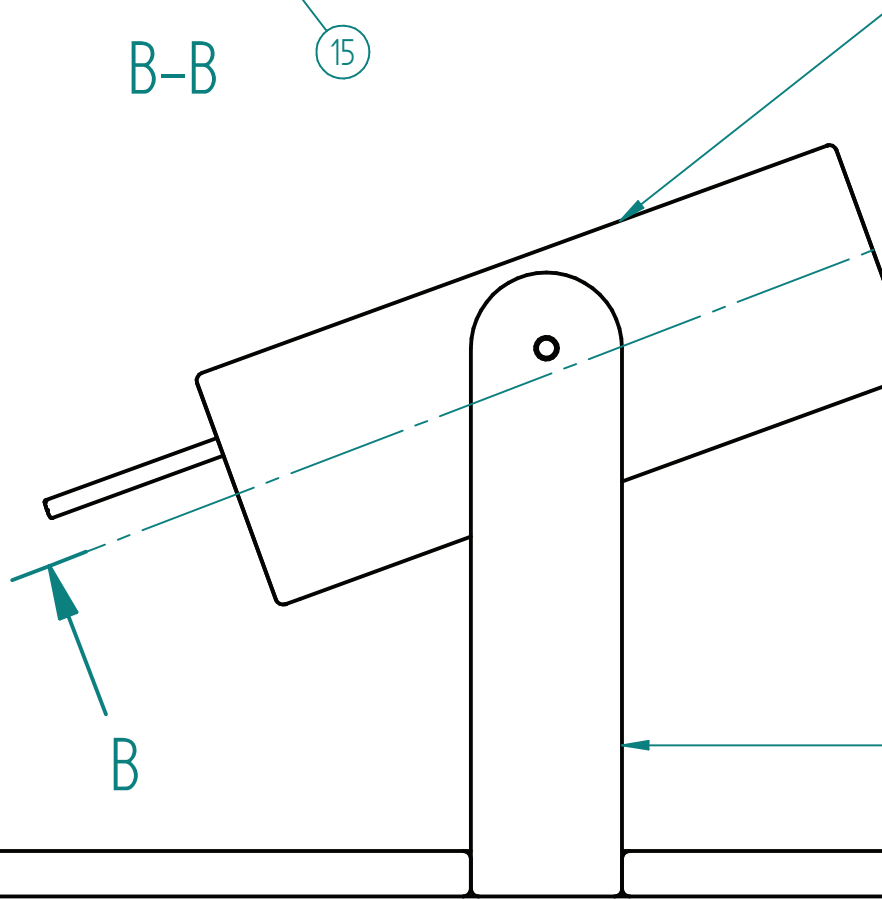
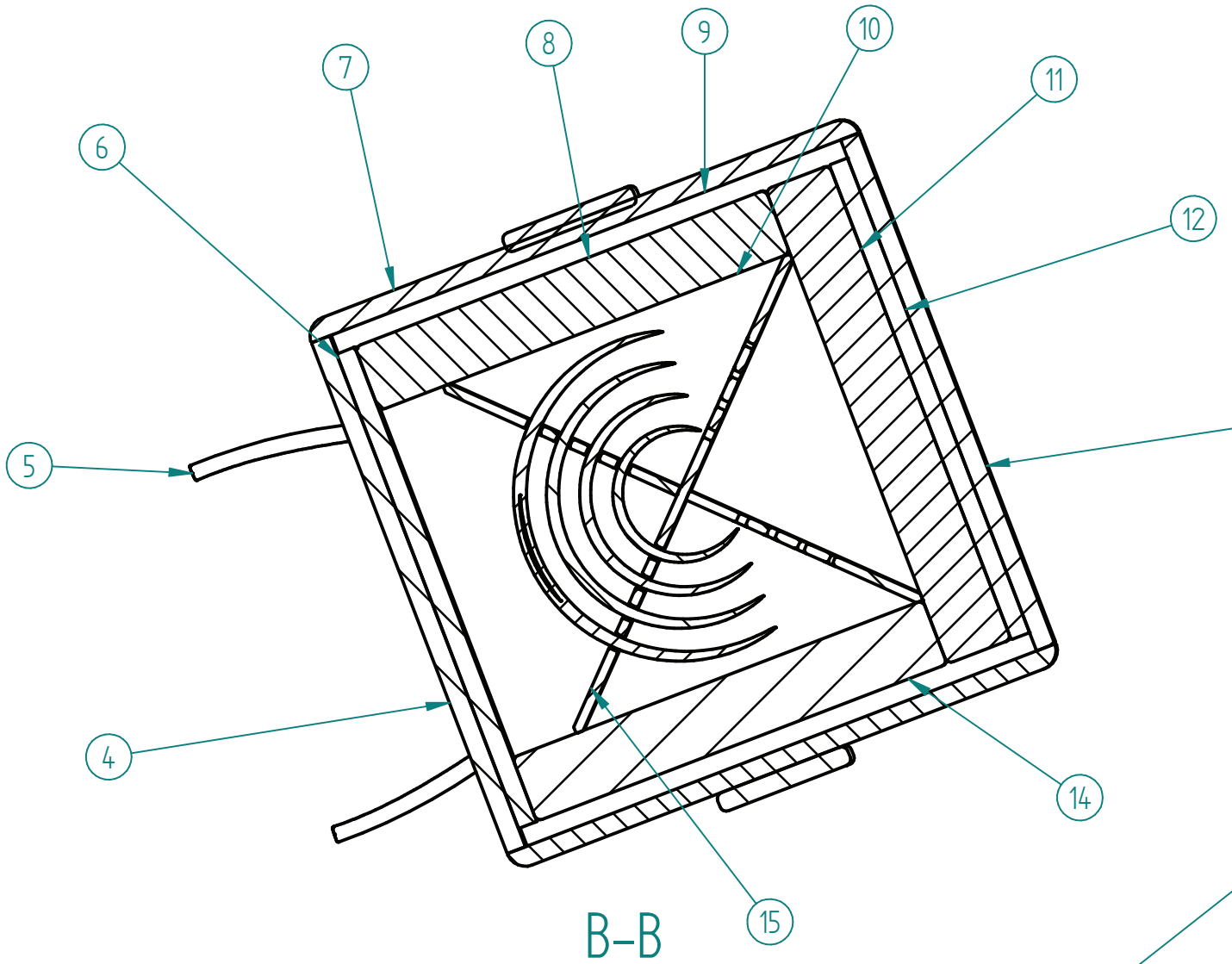

1

SOLID EDGE ACADEMIC COP

13

2



3

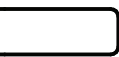

Y

15	Tube Support	2	Plywood	
14	Foam 3	1	Polyurethane foam	
13	Side 3	1	Plywood	
12	Support 3	1	Plywood	
11	Foam 2	2	Polyurethane foam	
10	Base	3	Plywood	
9	Support 2	2	Plywood	
8	Foam 1	1	Polyurethane foam	
7	Side 2	2	Plywood	
6	Support 1	3	Plywood	
5	Tubes	1	PVC	
4	Side 1	1	Plywood	
3	Stand	2	Plywood	
2	Glass	1	Plexyglass	
1	Base	1	Plywood	
N°	Name	QTY	Material	Notes

Solar thermal			A3
			8
			2:1



# Hydropower

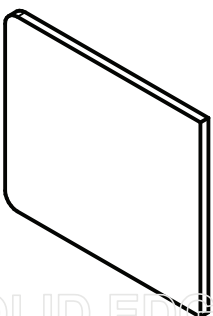
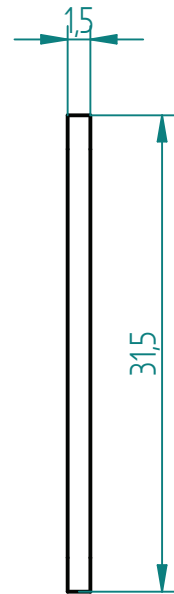
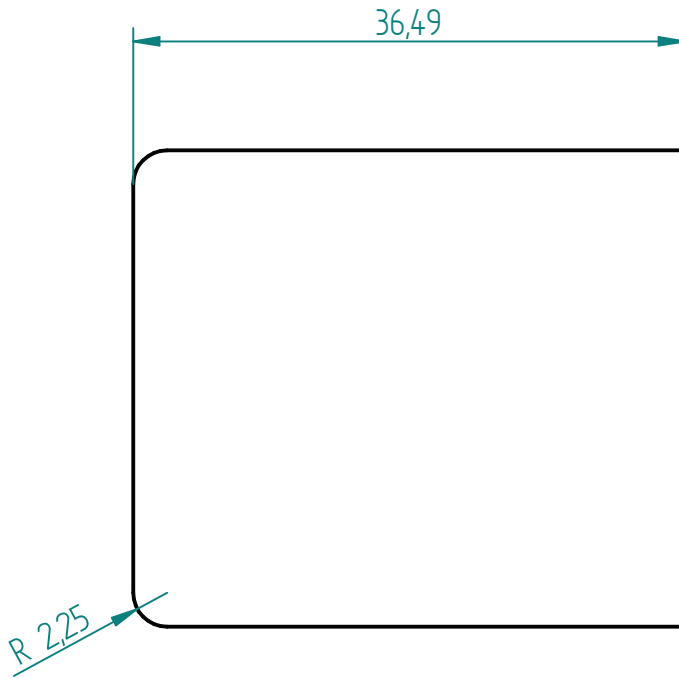

Glass	A4
	5
	2:1

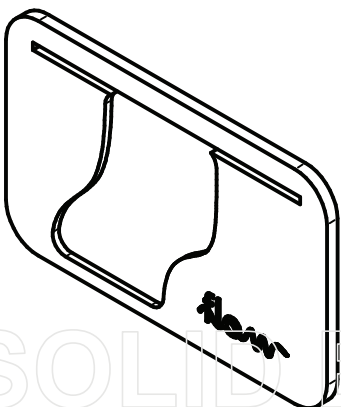
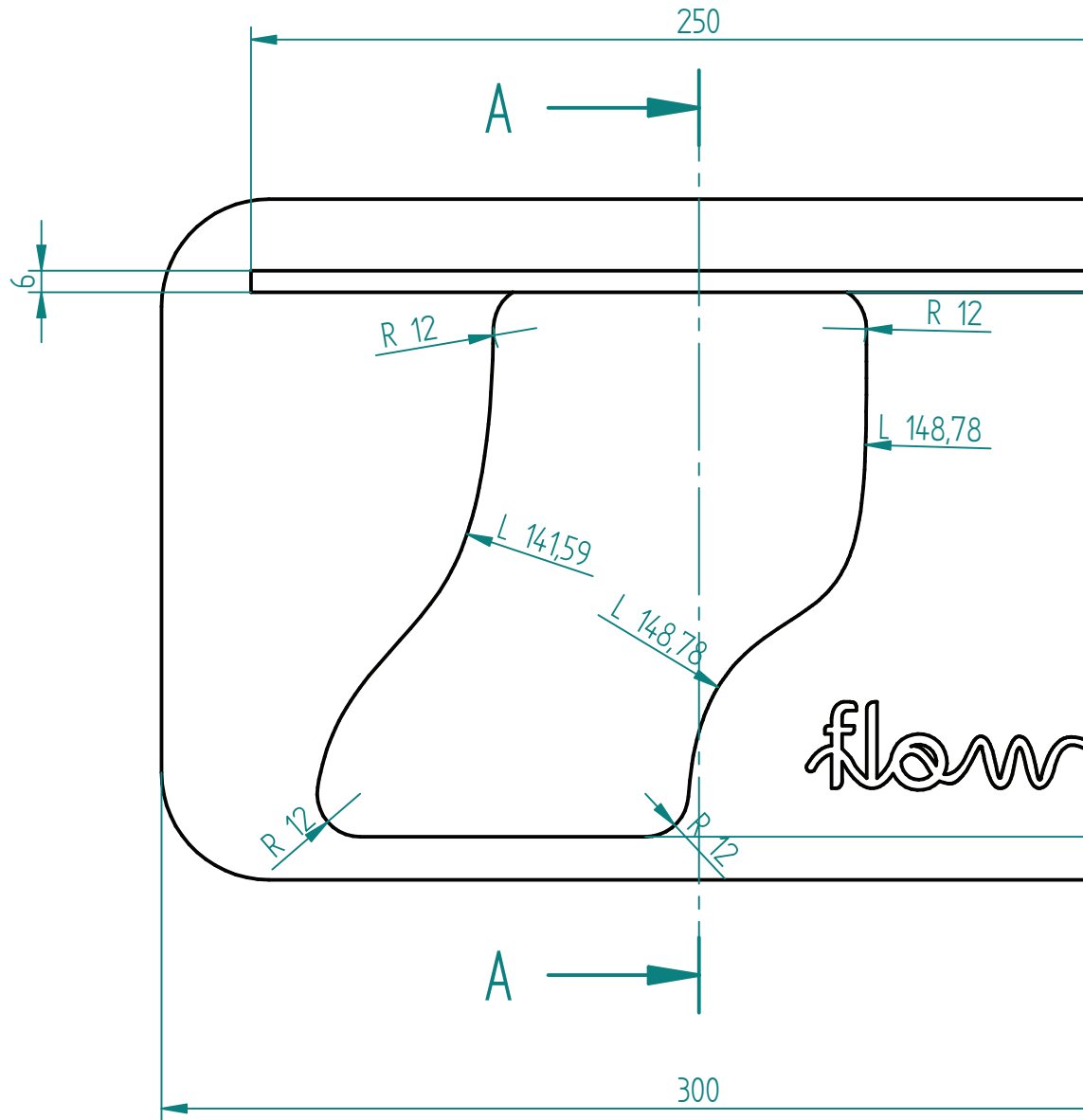

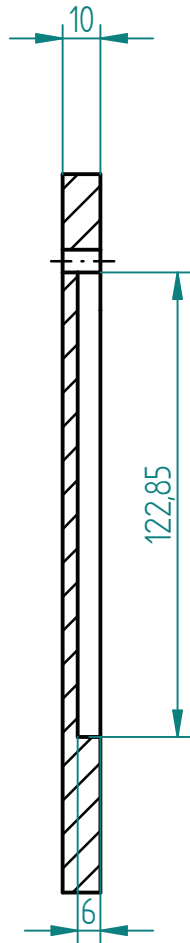
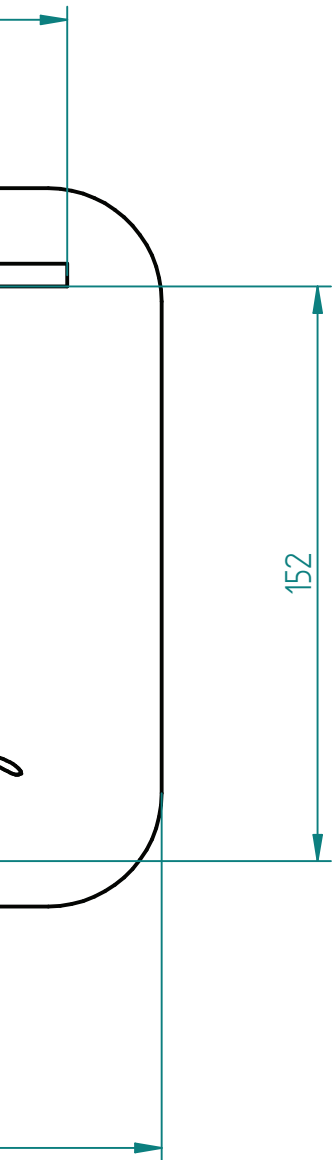

A-A

Base	A3
	1
	1:1

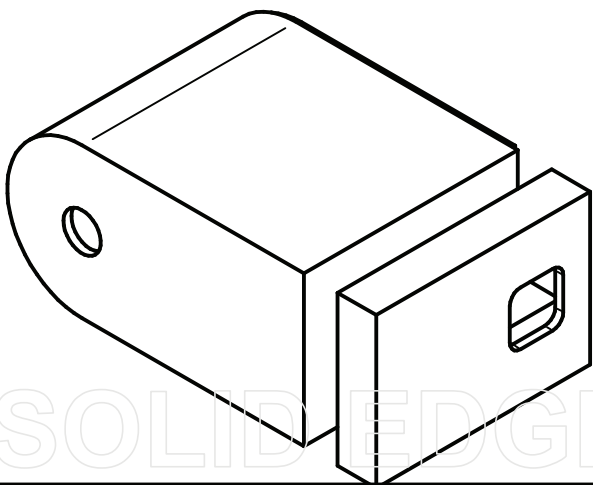
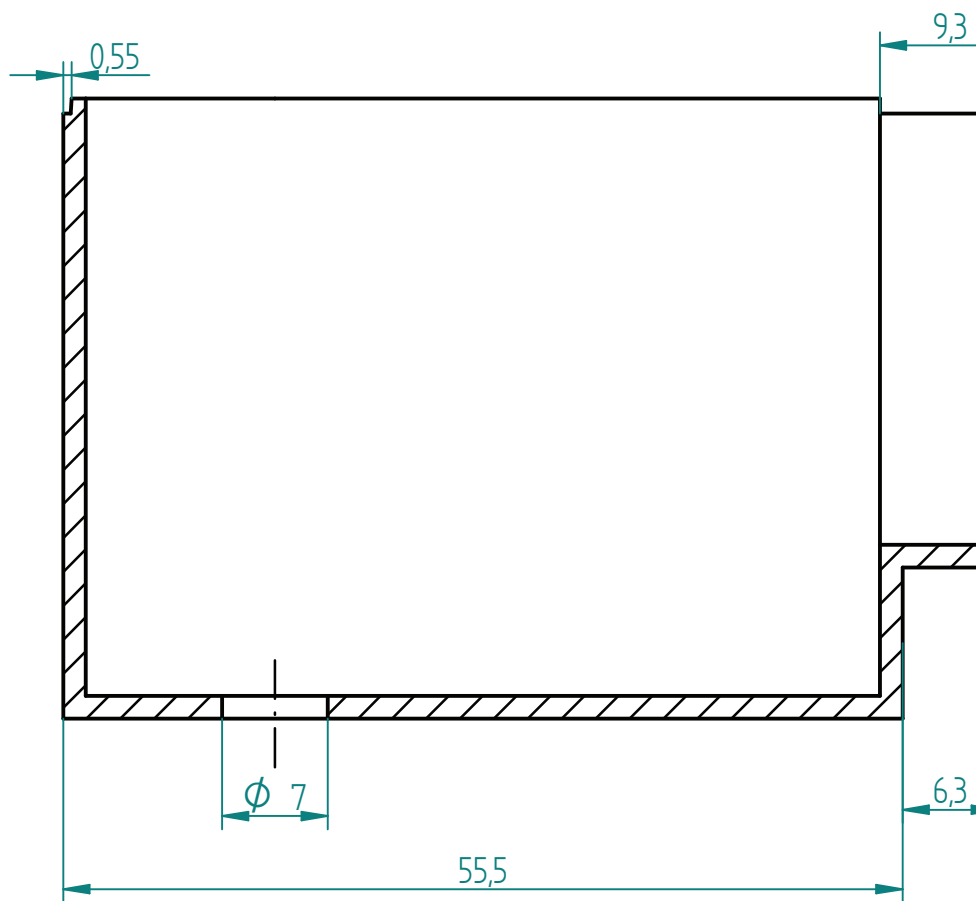
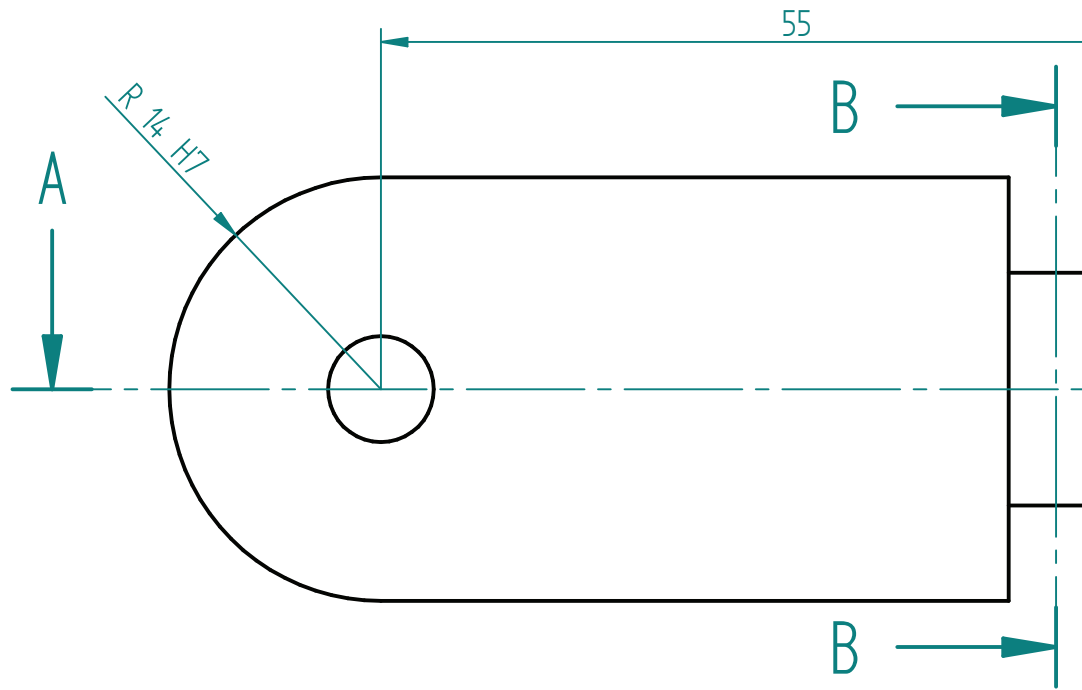

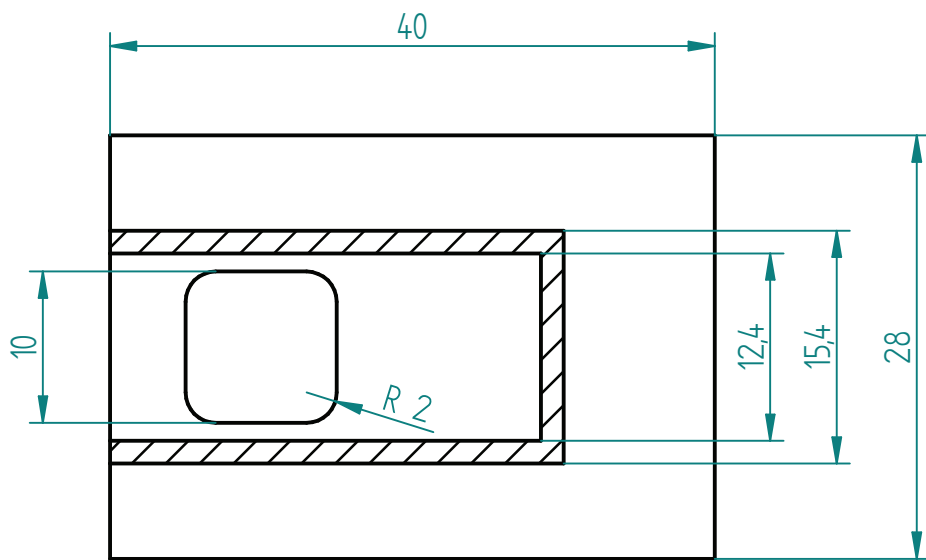
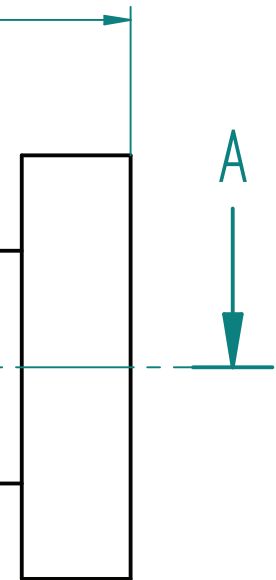

B-B

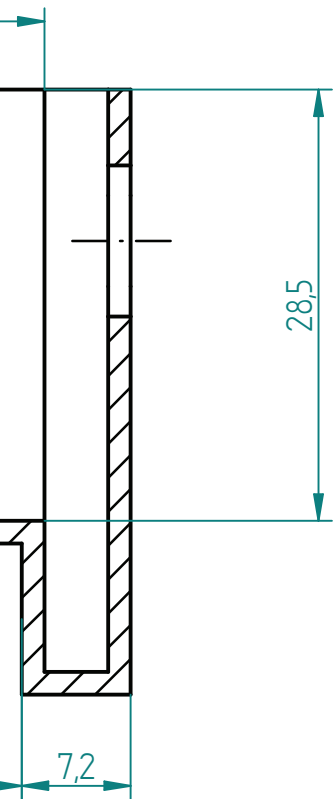

Engine case	A3
	7
	1:1

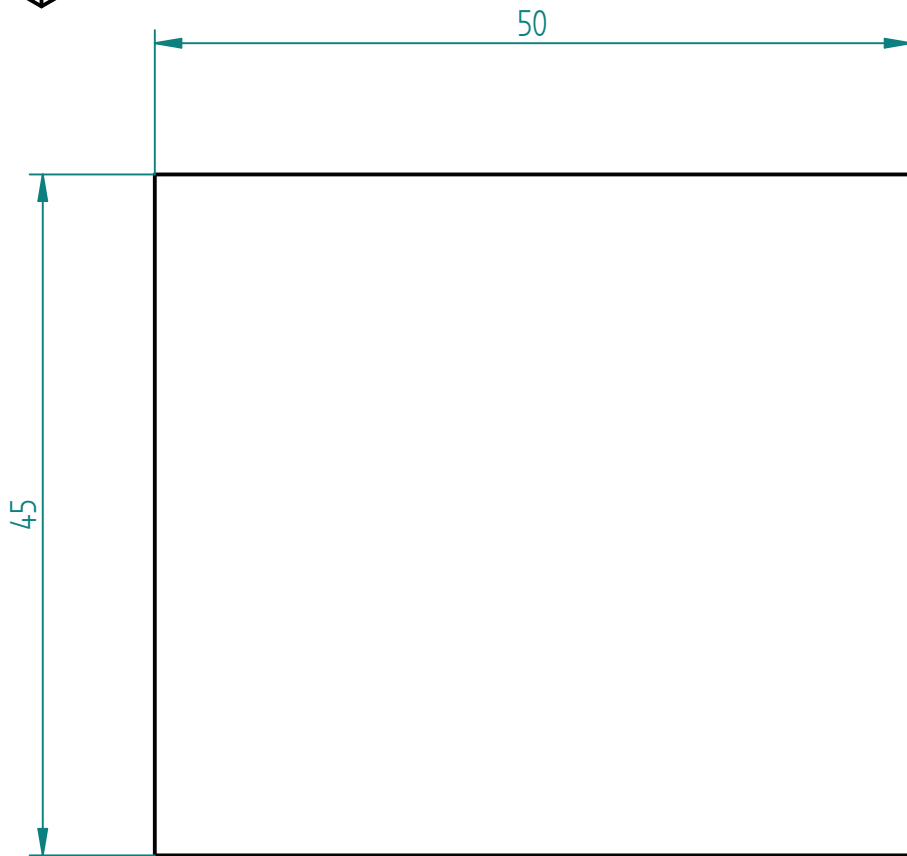
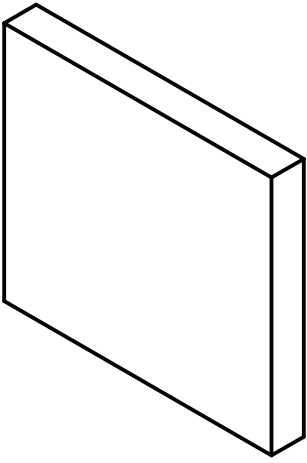

Horizontal base	A4
	3
	1:1

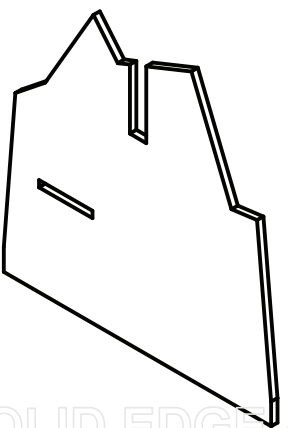
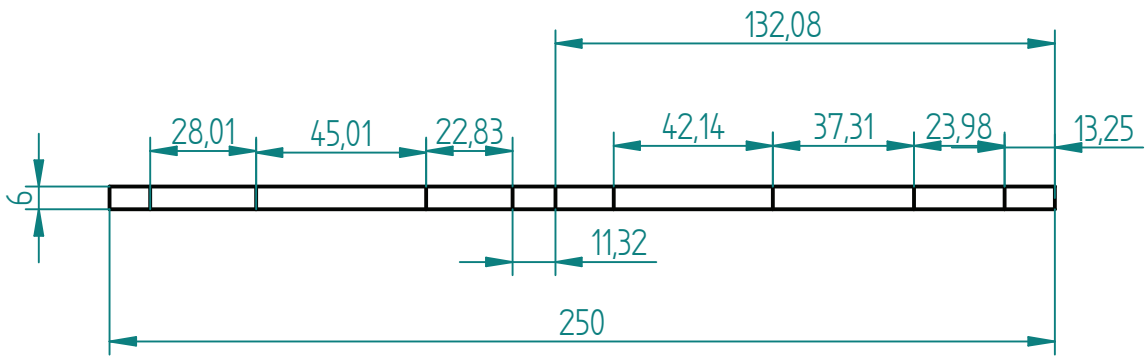
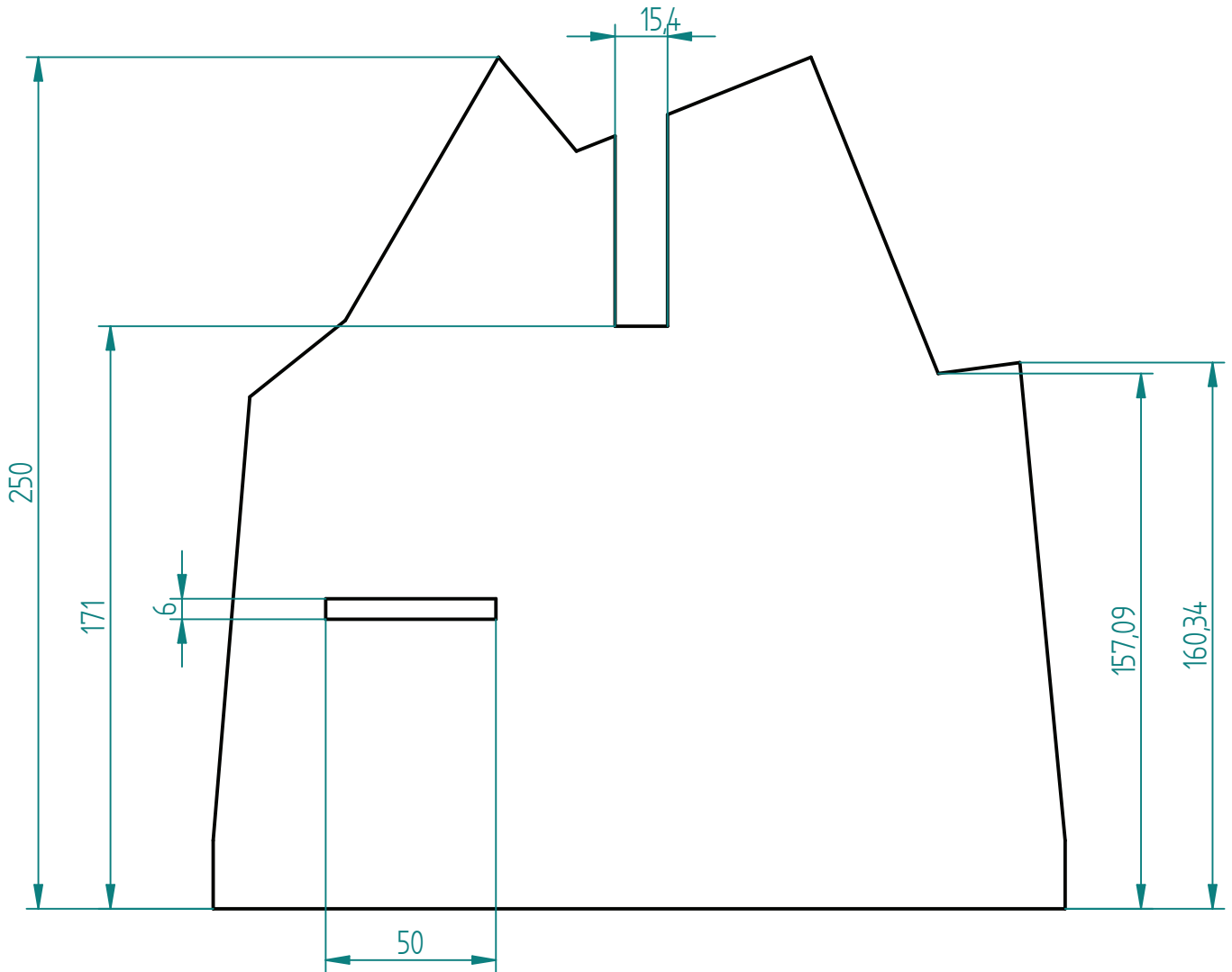



Mountain		A4
	2	
		1:2

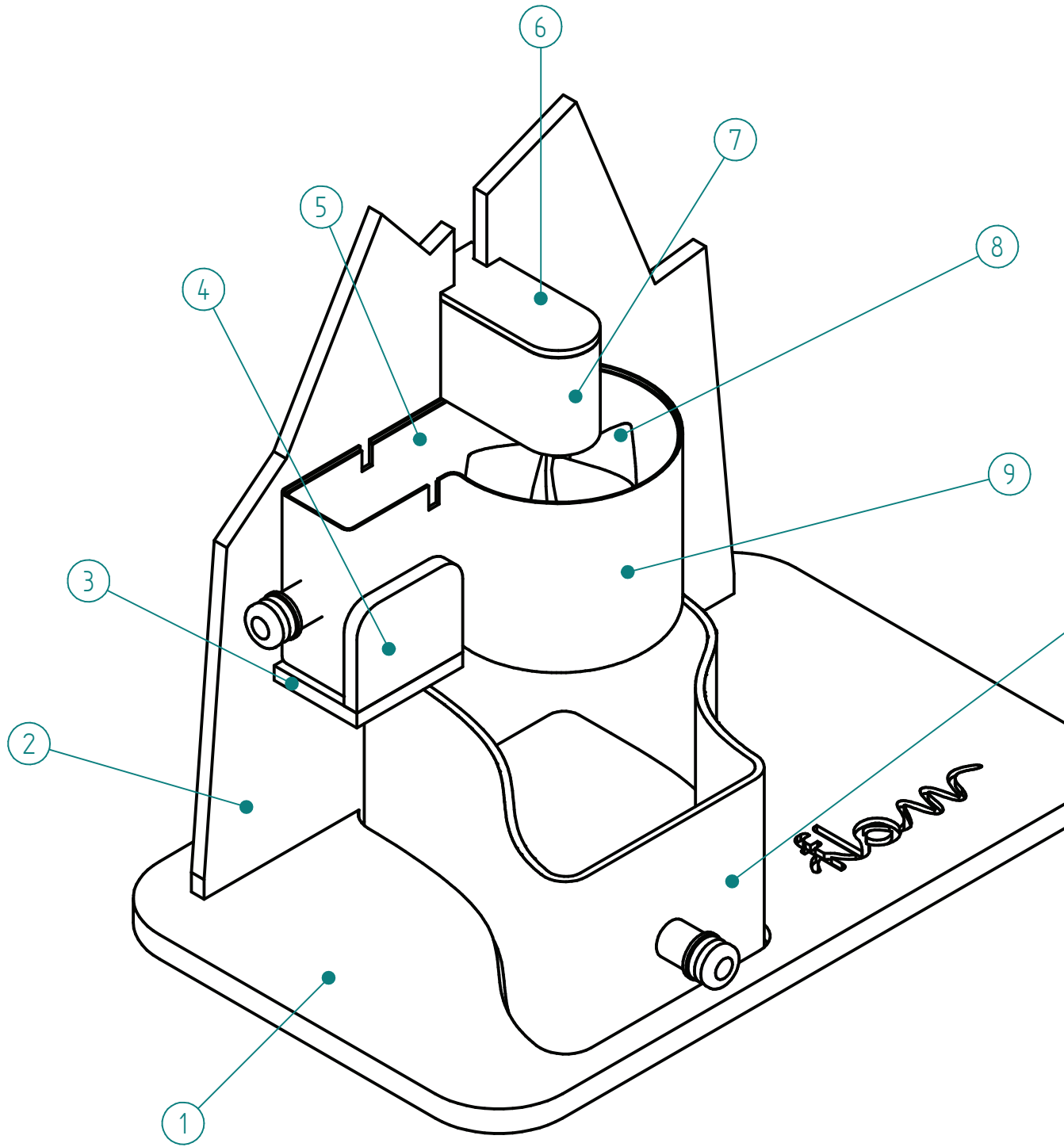

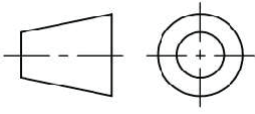

SOLID EDGE ACADEMIC COP

10	Pool	1	PLA	
9	vortex	1	PLA	
8	Turbine Kaplan	1	PLA	
7	Engine case	1	PLA	
6	Top Cover	1	PLA	
5	Glass	1	Plexiglass	
4	Vertical Base	1	PLA	
3	Horizontal Base	1	PLA	
2	Mountain	1	Plywood	
1	Base	1	Plywood	
N°	Name	QTY	Material	Notes
Hydropower				A3
				1
				1:1

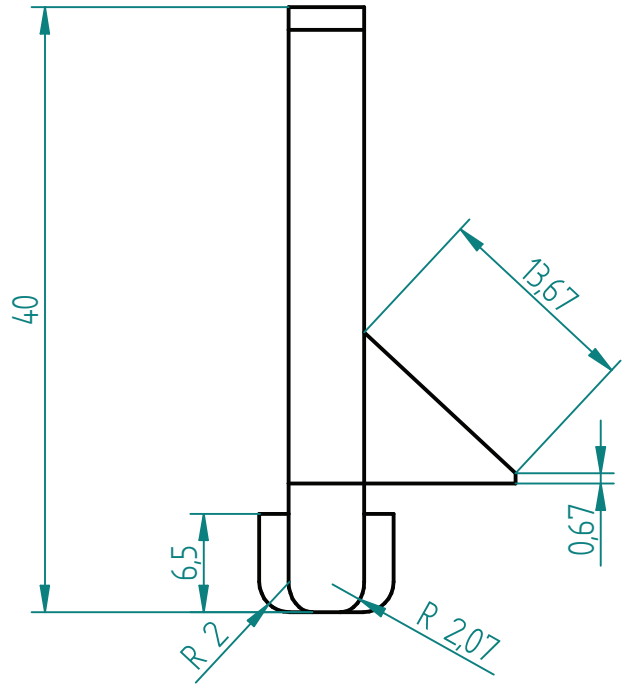
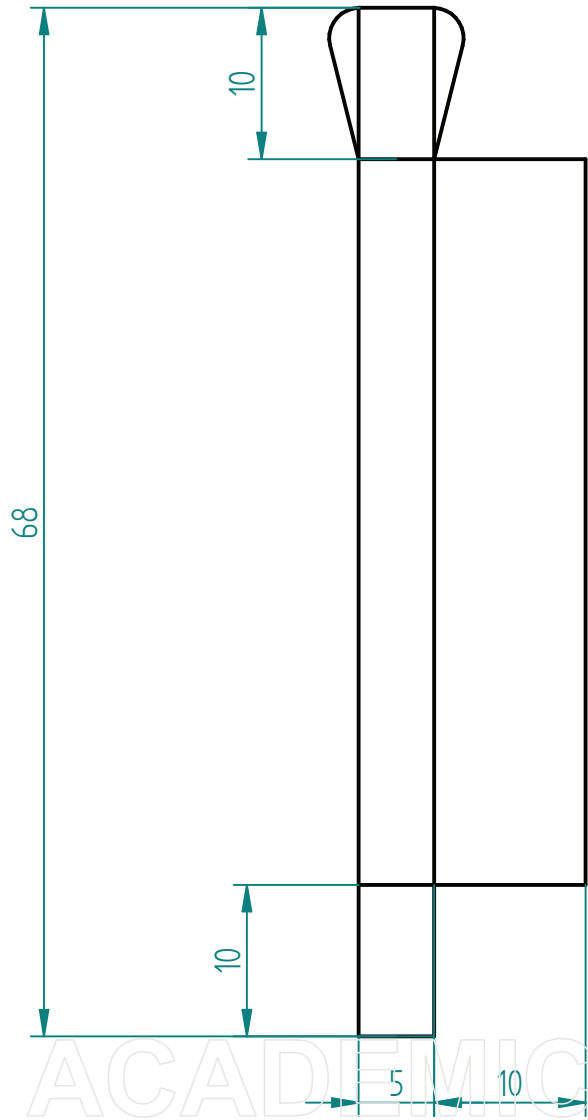
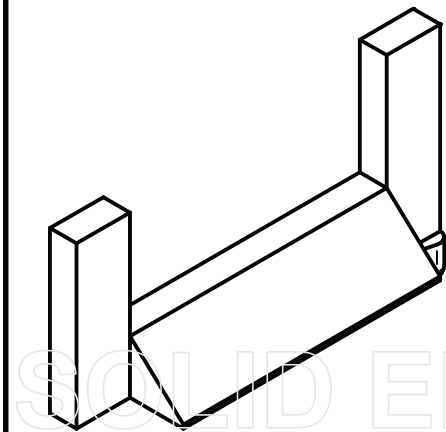

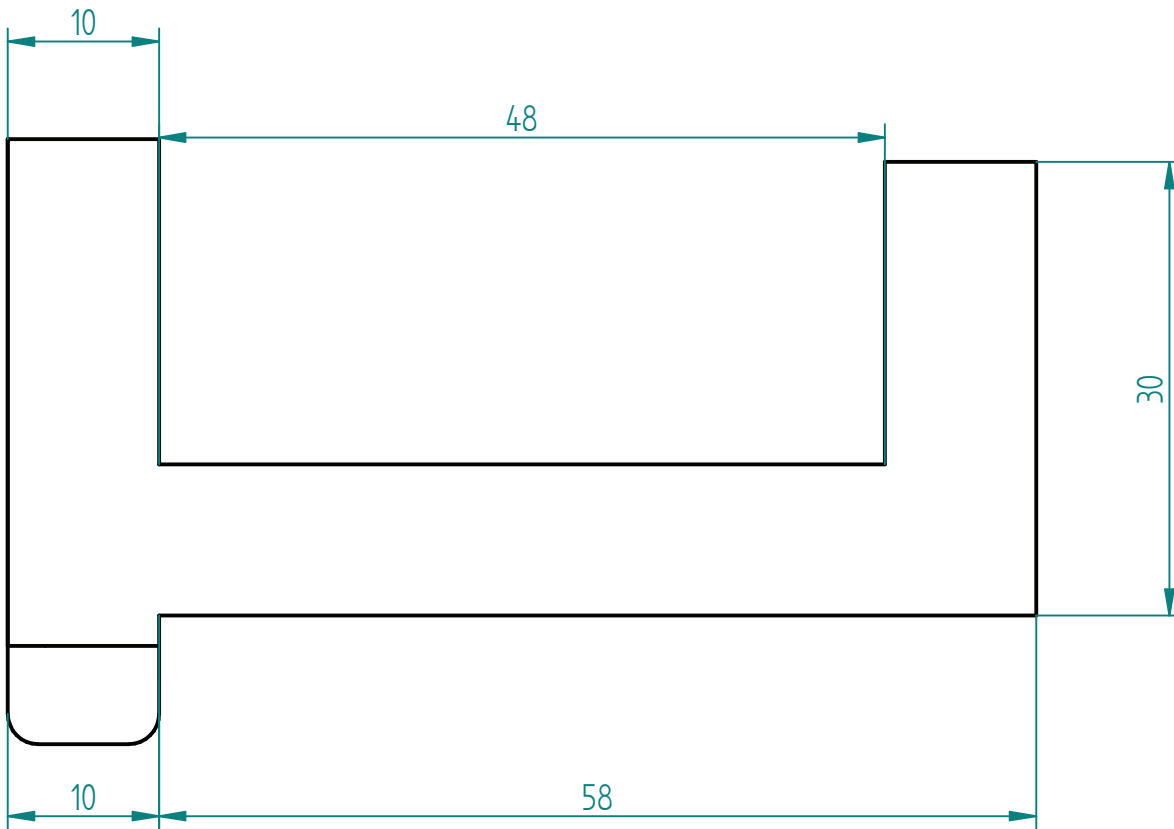

Nozzle 2		A3
		12
		2:1

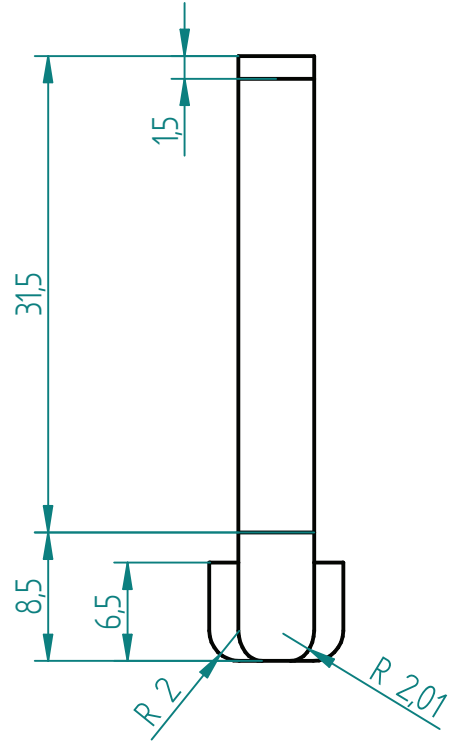
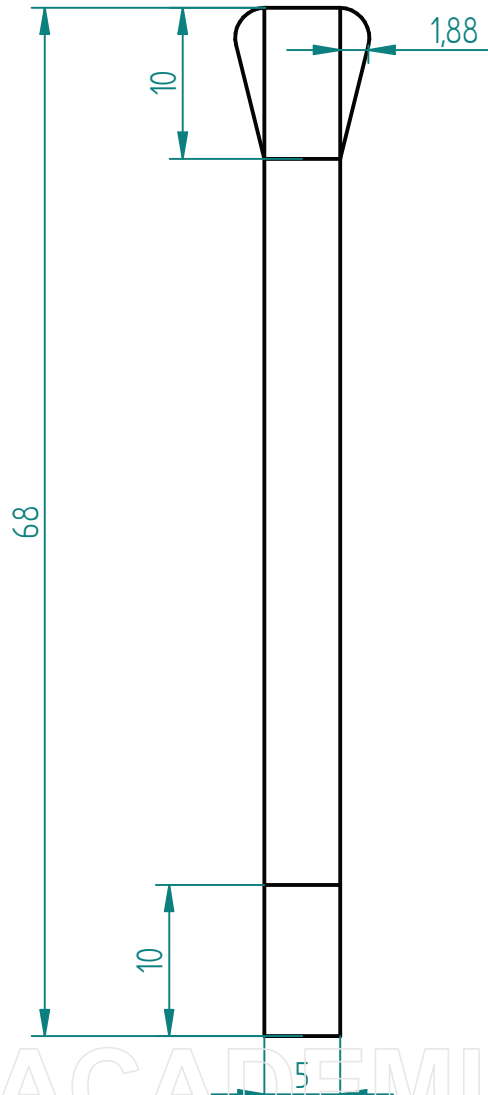
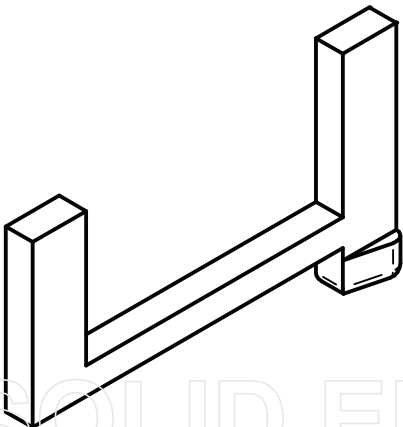

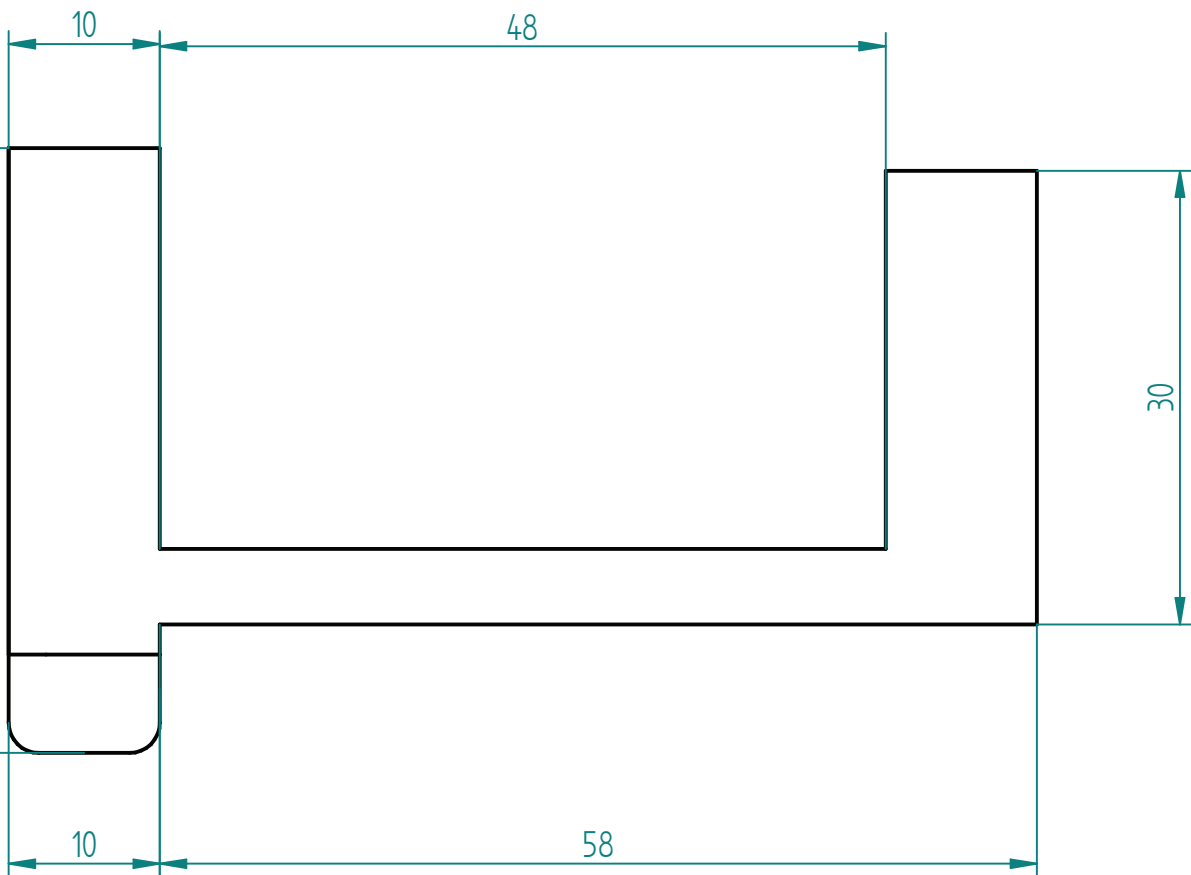

Nozzle 1	A3
	11
	2:1

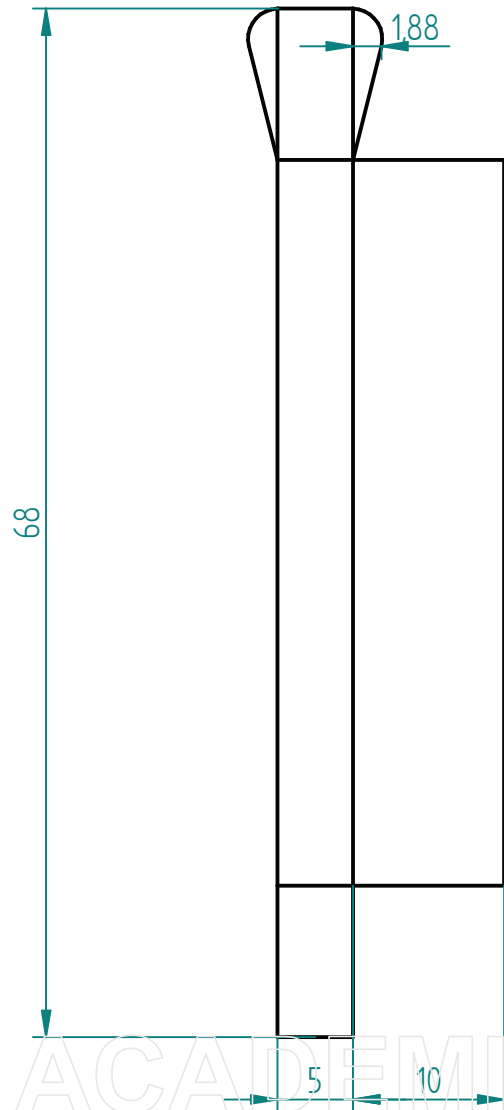
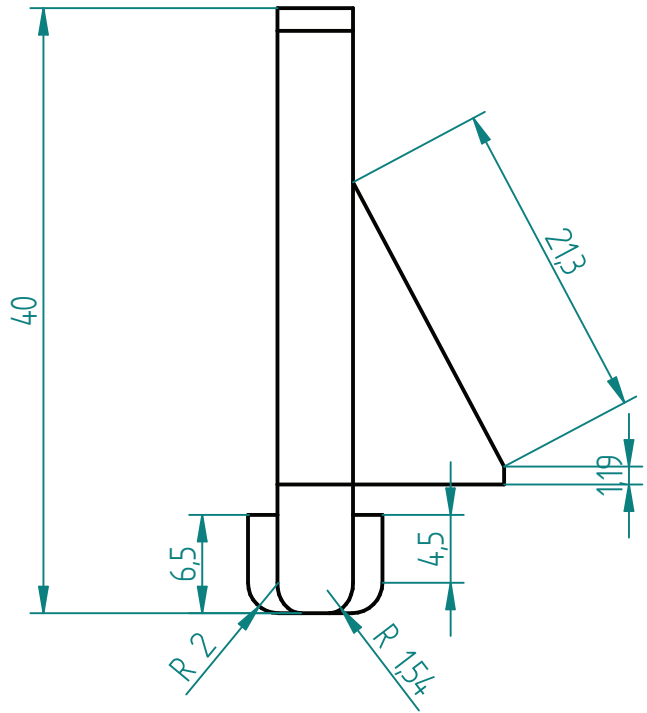
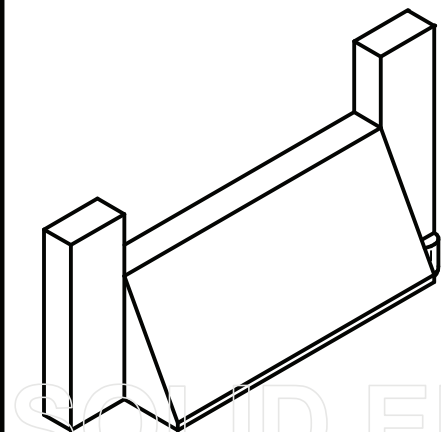

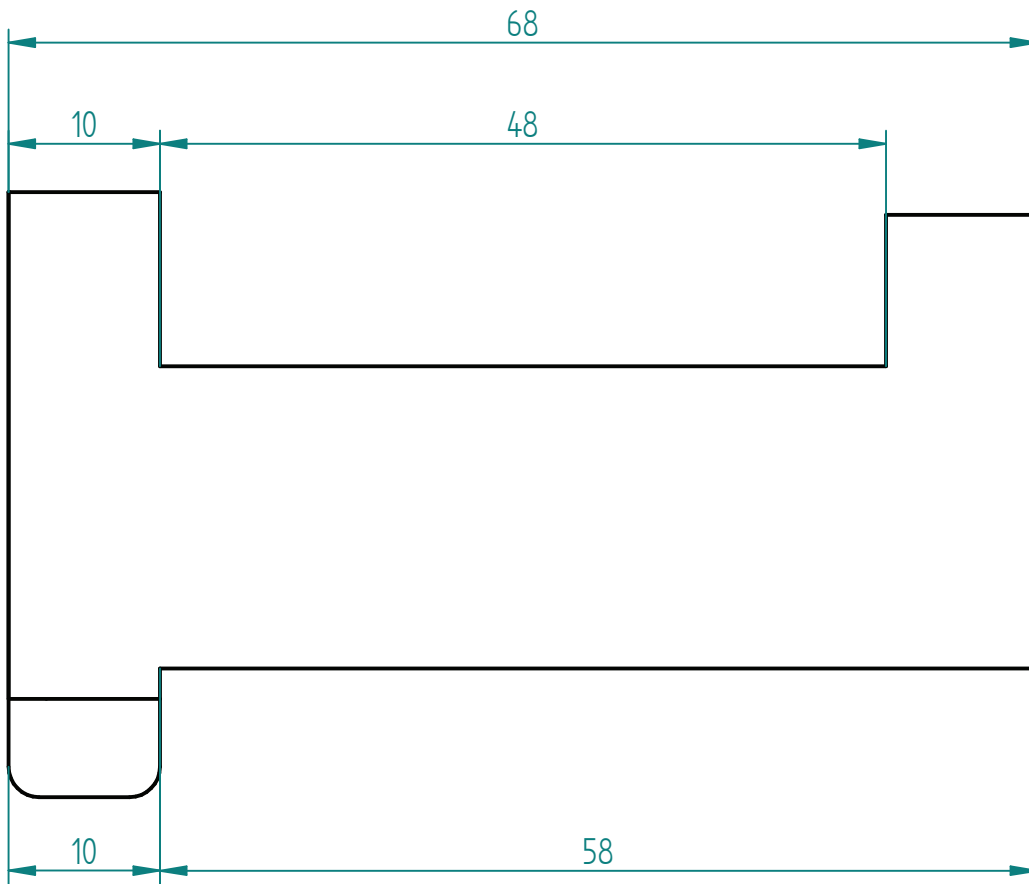



Nozzle 4		A3
		
	14	
		2:1

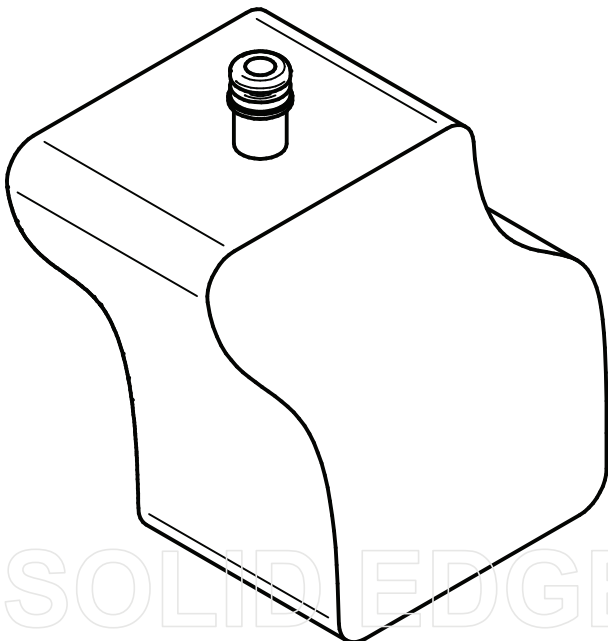
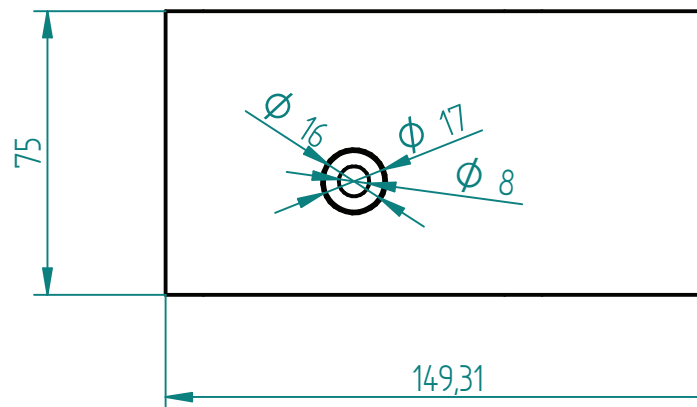
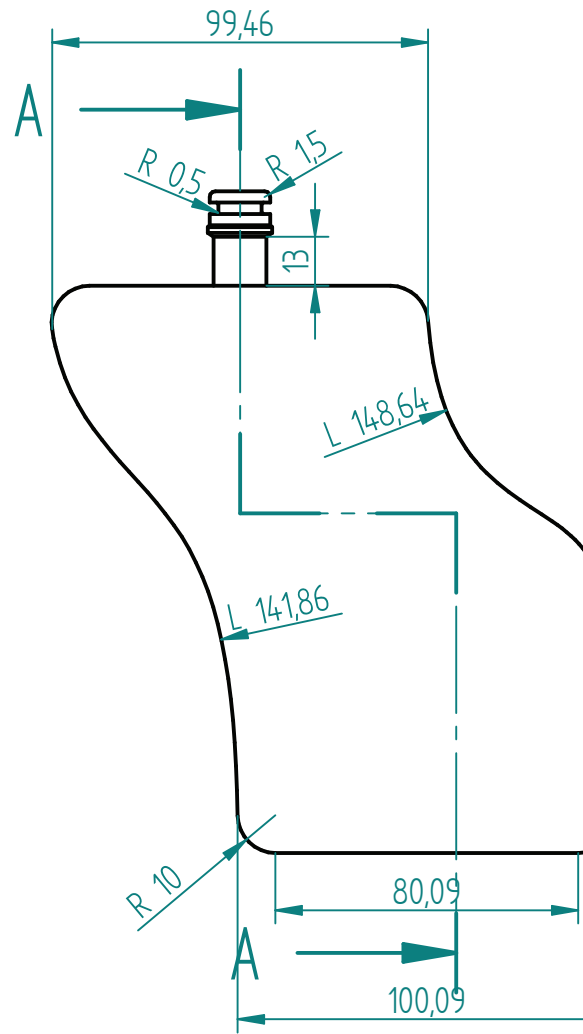

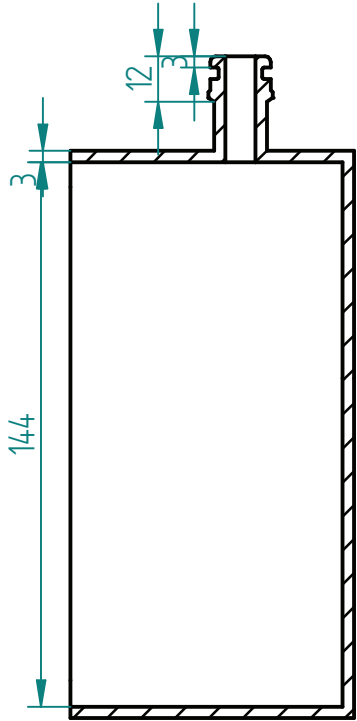

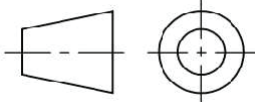

A-A

Pool	A3
	 Universiteit Antwerpen
	1:2

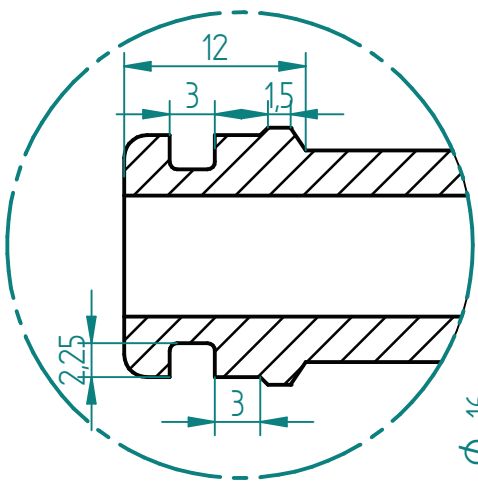
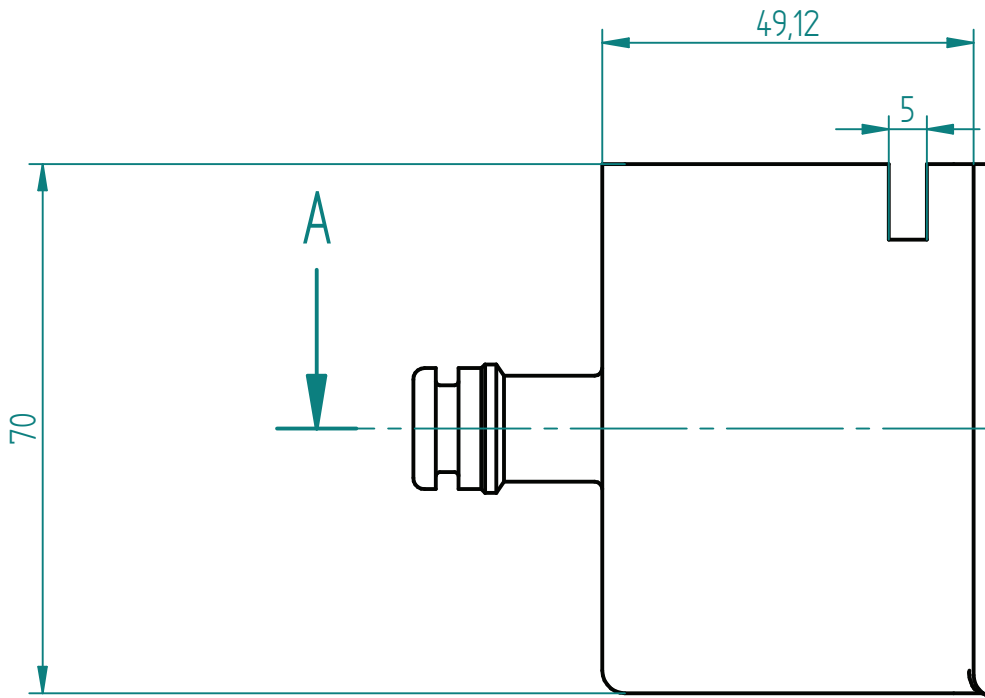

Detail B

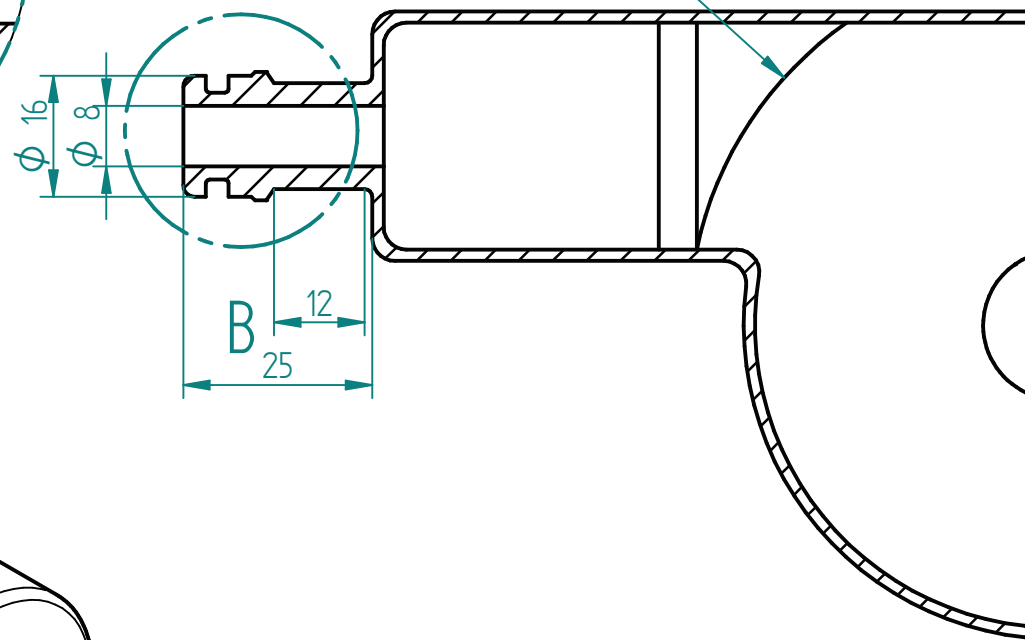

A-A

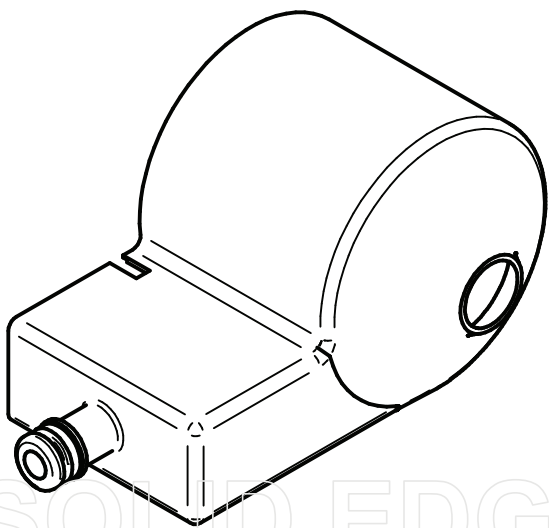

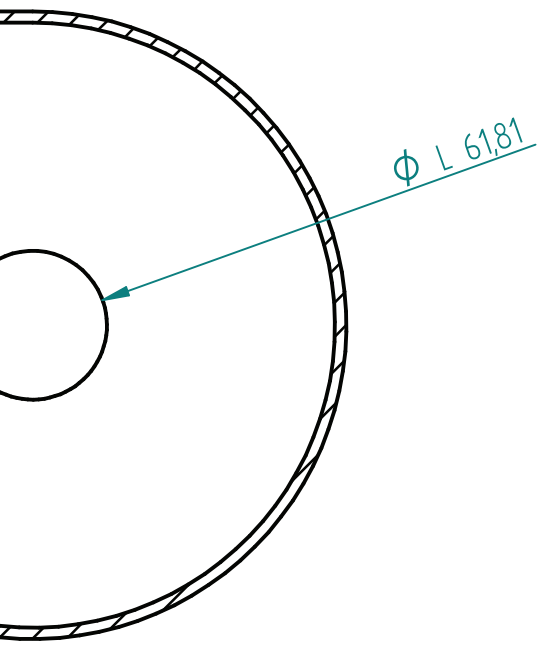
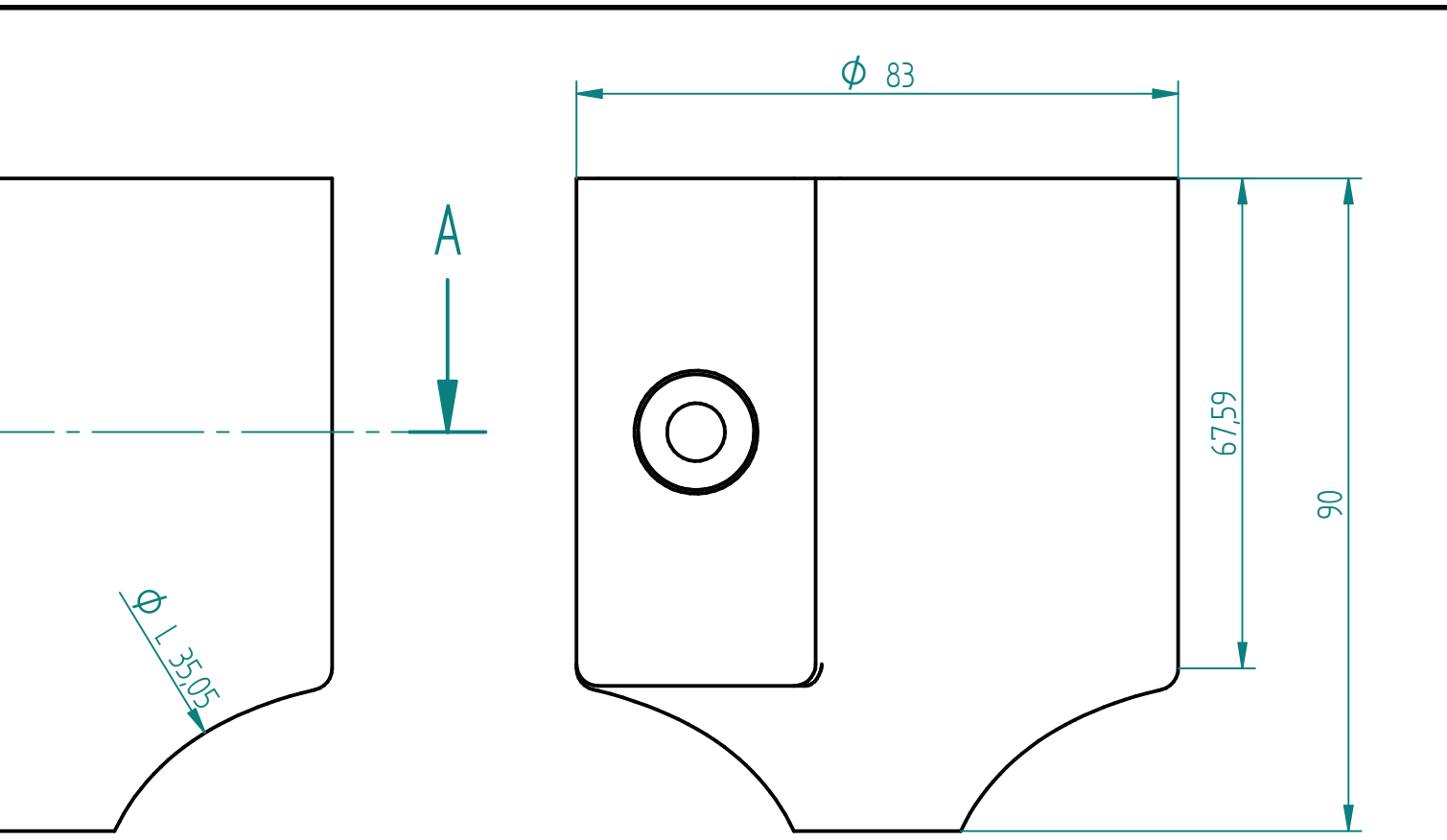

Vortex		A3
	9 1:1	

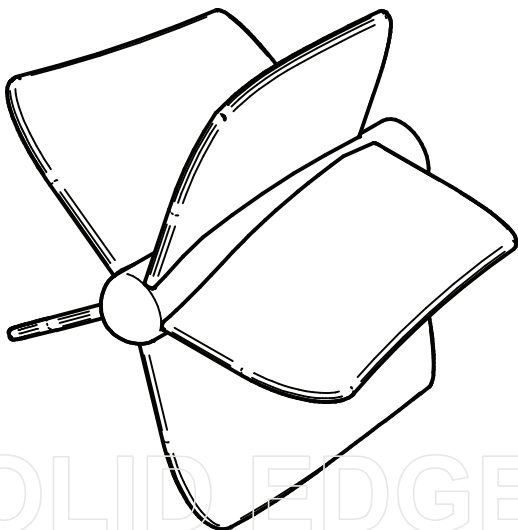
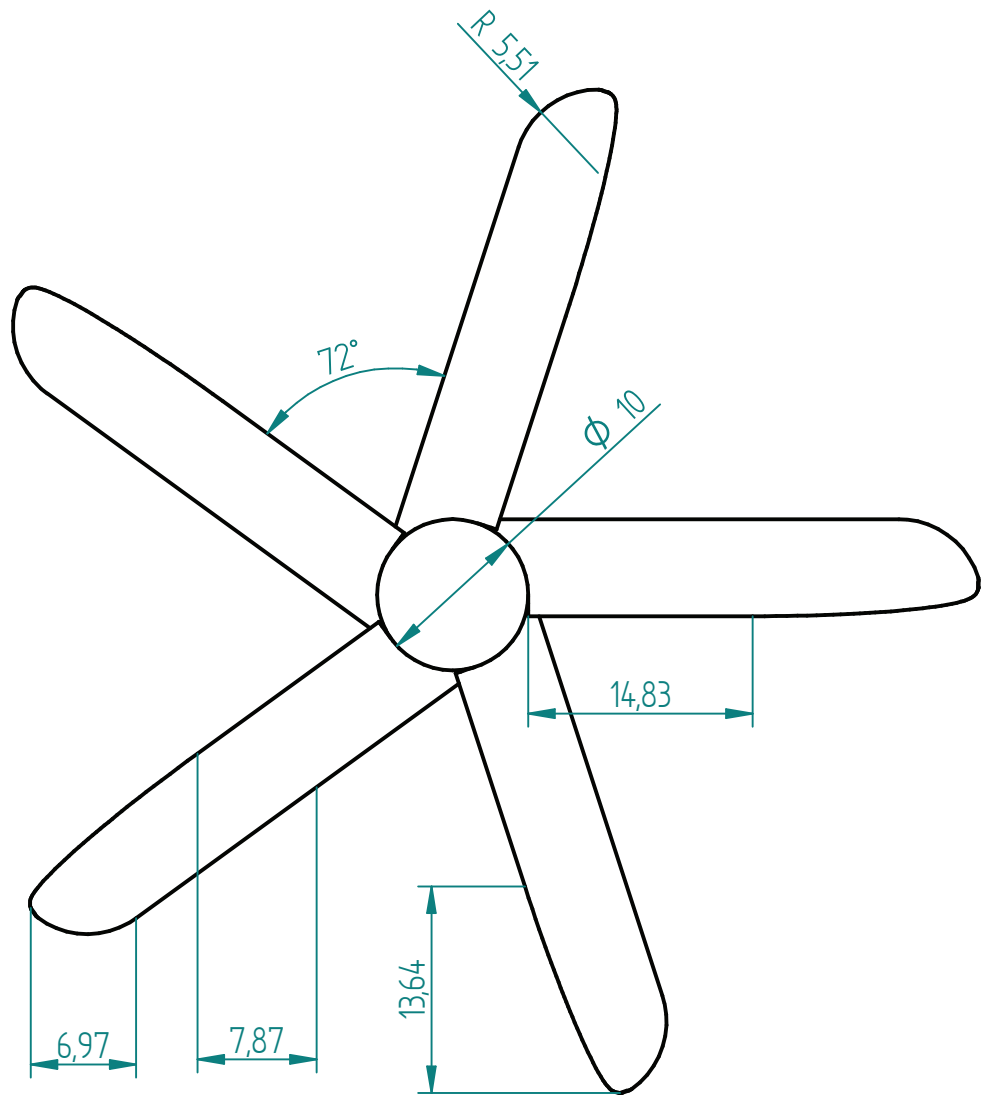

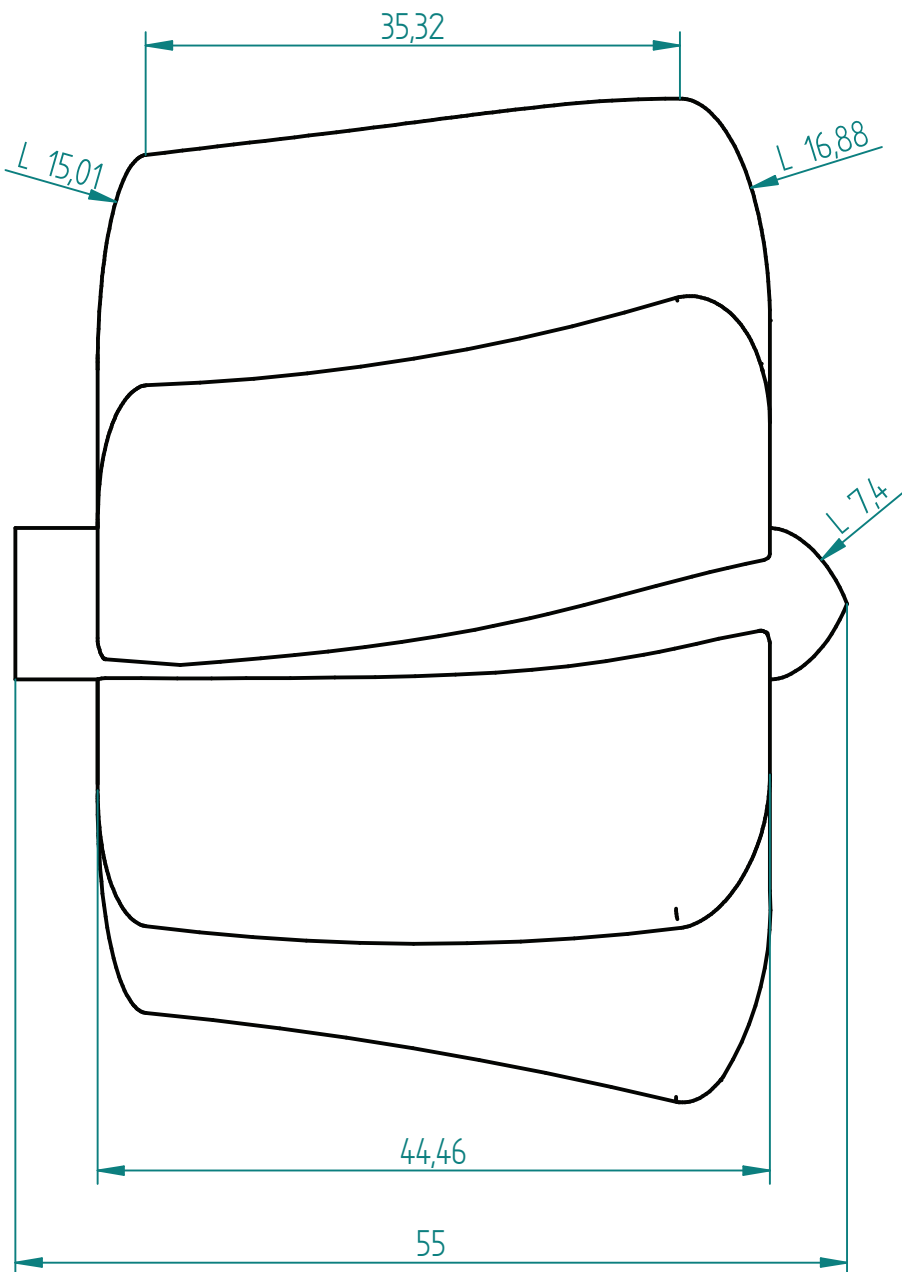

Turbine Kaplan	A3		
	<table border="1"> <tr> <td data-bbox="1364 1995 1519 2078">8</td> </tr> <tr> <td data-bbox="1364 2078 1519 2157">2:1</td> </tr> </table>	8	2:1
8			
2:1			

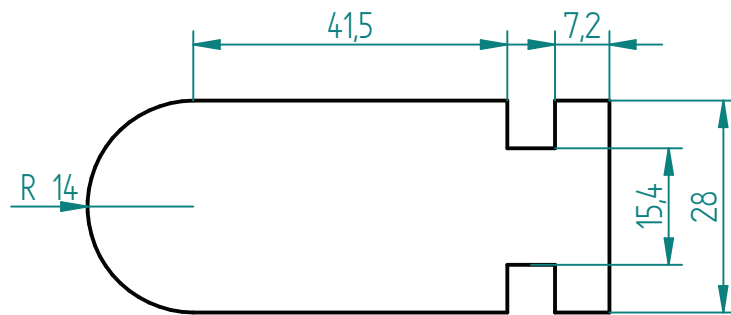
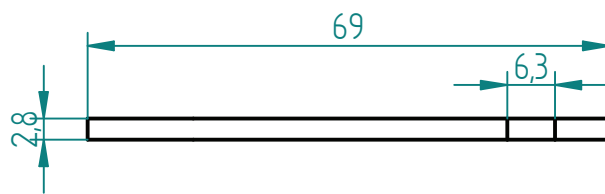
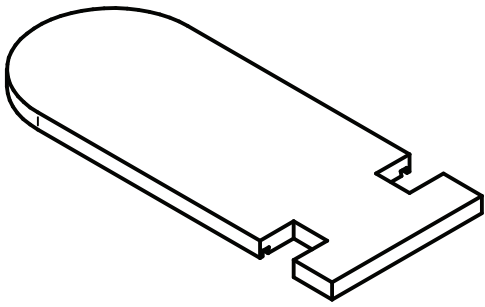

Top cover	A4
	6
	1:1





## APPENDIX M

### Arduino code and schematics

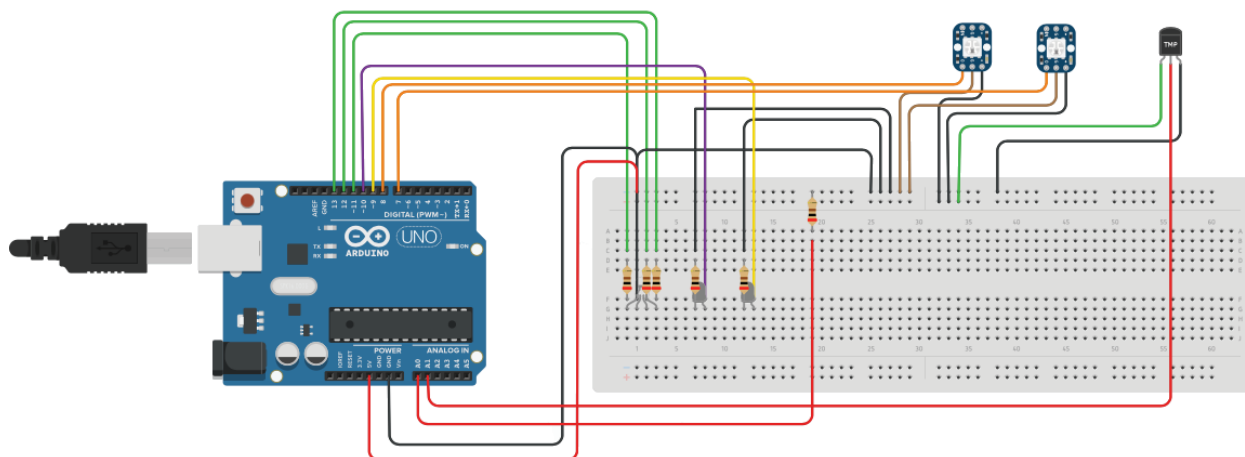

Schematics 1

Code for the windmill and the solar heater.

```
//Libraries and fixed variables
```

```
#include <Adafruit_NeoPixel.h>  
#include <dht.h>
```

```
dht DHT;
```

```
#define DHT11_PIN 6 // thermometer in digital 6
```

```
#define LightOneCount 1  
#define LightOnePin 8
```

```
#define LightTwoCount 1  
#define LightTwoPin 7
```

```
#define ledOne 10  
#define ledTwo 9
```

```
#define WindMill 0
```

```
//Objects
```

```

Adafruit_NeoPixel LightOne = Adafruit_NeoPixel(LightOneCount, LightOnePin, NEO_GRB +
NEO_KHZ800);
Adafruit_NeoPixel LightTwo = Adafruit_NeoPixel(LightTwoCount, LightTwoPin, NEO_GRB +
NEO_KHZ800);

//Variables

int analogVal = 0;
float voltage = 0;
int celsius = 0;

// limits

float WMmaximum = 1;
float WMmedium = 0.7;
float WMminimum = 0.5;

int redPinOne = 11;
int greenPinOne = 12;
int bluePinOne = 13;

long WarmYellow = LightOne.Color(253,184,19);

long ColdBlue = LightTwo.Color(45,100,245);
long LightBlue = LightTwo.Color(135,206,250);
long LightYellow = LightTwo.Color(255,255,224);
long WarmRed = LightTwo.Color(224,0,52);

long Tcolor = ColdBlue;
long Tnew = 0;

//Functions

void setup() {
  Serial.begin (9600); //serial monitor on

  // LED in output

  pinMode(redPinOne, OUTPUT);
  pinMode(greenPinOne, OUTPUT);
  pinMode(bluePinOne, OUTPUT);

  pinMode(ledOne, OUTPUT);
  pinMode(ledTwo, OUTPUT);

  LightOne.begin();

```

```

LightOne.clear();
LightOne.show();

LightTwo.begin();
LightTwo.clear();
LightTwo.show();

// LED on

digitalWrite(ledOne,HIGH);
digitalWrite(ledTwo,HIGH);
digitalWrite(greenPinOne,HIGH);

LightOne.setPixelColor(0,WarmYellow);
LightOne.show();

LightTwo.setPixelColor(0,ColdBlue);
LightTwo.show();
delay(1000);
}

void loop() {

// Shut down LED
digitalWrite(ledOne,LOW);
digitalWrite(ledTwo,LOW);
digitalWrite(greenPinOne,LOW);
digitalWrite(bluePinOne, LOW);

LightOne.setPixelColor(0,0,0,0);
LightOne.show();
delay(5);

//START WINDMILL
analogVal = analogRead(WindMill);
// Read voltage
voltage = 0.0048 * (analogVal);
Serial.println ( "Voltage: ");
Serial.println (voltage);

// PHASE ONE (0 - minimum)
if(voltage <= WMminimum){
digitalWrite (ledOne, HIGH);
}
}

```

```

// PHASE TWO (minimum - medium)
if(WMminimum < voltage && voltage <= WMmedium){
digitalWrite (ledOne, HIGH);

digitalWrite (ledTwo,HIGH);

}

// PHASE THREE (medium - maximum)
if(WMmedium < voltage && voltage < WMmaximum){
digitalWrite (ledOne, HIGH);

digitalWrite (ledTwo,HIGH);

for(int i = 0; i < 3; i++){
digitalWrite(redPinOne, HIGH);
digitalWrite(bluePinOne, LOW);
delay(50);
digitalWrite(greenPinOne, HIGH);
digitalWrite(redPinOne, LOW);
delay(50);
digitalWrite(bluePinOne,HIGH);
digitalWrite(greenPinOne, LOW);
delay(50);
}
}

// PHASE FOUR ( > maximum)
if(WMmaximum <= voltage){
digitalWrite (ledOne, HIGH);

digitalWrite (ledTwo,HIGH);

for(int i = 0; i < 3; i++){
digitalWrite(redPinOne, HIGH);
digitalWrite(bluePinOne, LOW);
delay(50);
digitalWrite(greenPinOne, HIGH);
digitalWrite(redPinOne, LOW);
delay(50);
digitalWrite(bluePinOne,HIGH);
digitalWrite(greenPinOne, LOW);
delay(50);
}
LightOne.setPixelColor(0,WarmYellow);
LightOne.show();
delay(1000);

```

```

}

// HEAT SHOWER
//Read temperature
int celsius = DHT.read11(DHT11_PIN);
delay(500);

    // Phase 1 (0 - 25)
    if(DHT.temperature <= 25){
        LightTwo.setPixelColor(0, ColdBlue);
        LightTwo.show();
    }
    // Phase 2 (25 - 35)
    if(25 < DHT.temperature && DHT.temperature <= 35){
        LightTwo.setPixelColor(0, LightBlue);
        LightTwo.show() ;
    }
    // Phase 3 (35 - 45)
    if(35 < DHT.temperature && DHT.temperature <= 45){
        LightTwo.setPixelColor(0, LightYellow);
        LightTwo.show() ;
    }
    // Phase 4 (45 - max)
    if(DHT.temperature > 45){
        LightTwo.setPixelColor(0, WarmRed);
        LightTwo.show() ;
    }

delay(1000);

}

```

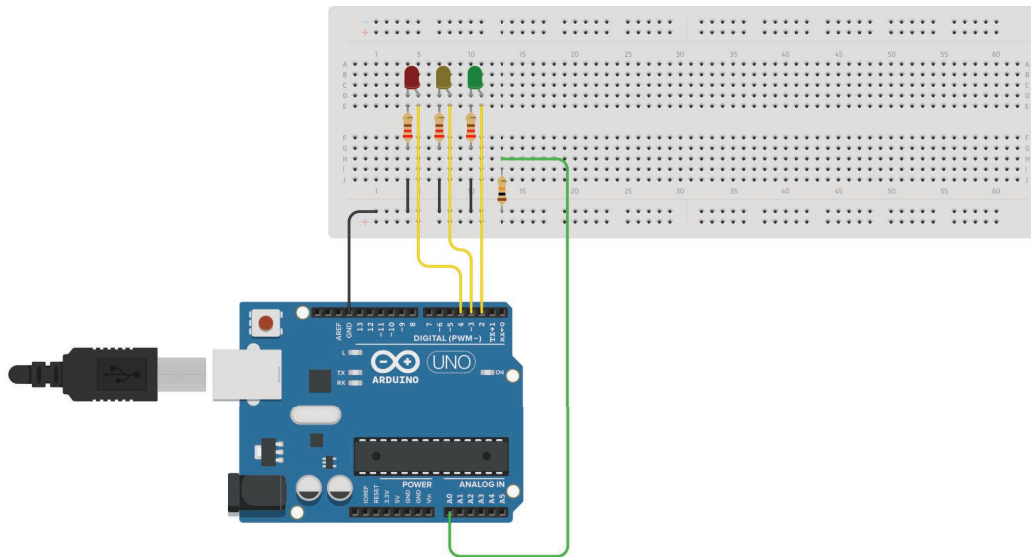

*Schematics 2*

Code for the water turbine

```
#define GREENLED 2
#define YELLOWLED 3
#define REDLED 4
#define ANALOGPILA 0

// Variables
int analogValor = 0;
float voltage = 0;
int ledDelay = 800;

// Limits
float maxim = 1;
float medium = 0.5;
float minimum = 0.2;

void setup() {
  // Serial monitor on
  Serial.begin(9600);

  // LED pines in output mode
  pinMode(GREENLED, OUTPUT);
  pinMode(YELLOWLED, OUTPUT);
  pinMode(REDLED, OUTPUT);
}

void loop() {
  // We read the analog input
```

```

analogValor = analogRead(ANALOGPILA);

// We obtain the voltage
voltage = 0.0048 * analogValor;
Serial.print("Voltage: ");
Serial.println(voltage);

// Depending on the voltage we show one LED or another
if (voltage >= maxim)
{
  digitalWrite(GREENLED, HIGH);
  delay(ledDelay);
  digitalWrite(GREENLED, LOW);
}
else if (voltage < maxim && voltage > medium)
{
  digitalWrite(YELLOWLED, HIGH);
  delay(ledDelay);
  digitalWrite(YELLOWLED, LOW);
}
else if (voltage < medium && voltage > minimum)
{
  digitalWrite(REDLED, HIGH);
  delay(ledDelay);
  digitalWrite(REDLED, LOW);
}

// All LEDs off
digitalWrite(GREENLED, LOW);
digitalWrite(YELLOWLED, LOW);
digitalWrite(REDLED, LOW);
}

```

# APPENDIX N

## Business Canvas

For the course Business Model Canvas, we had to create three different canvases on the Osterwalder format. See below an overview of our different canvases:

### 1. Energy Wizards:

An educational toolkit consisting of three experiments. These experiments link renewable energy to the physics learned in class. The toolkit is a STEM-initiative developed to be used in Flemish secondary schools.

<b>The Canvas</b>	<b>Key Partners</b> - STEM - School contact - UAntwerpen - Regan	<b>Key Activities</b> - Experiments - Keep contact with the teachers	<b>Value Propositions</b> - Raise awareness - Raise knowledge - Context and inspiration - Appetize for STEM - Science attractive	<b>Customer Relationships</b> - Follow up - Progress contact - Feedback - Midterm evaluation	<b>Customer Segments</b> - Kids - Teachers
		<b>Key Resources</b> - Data/information - Budget - Infrastructure - Testing with kids		<b>Channels</b> - Mail - Phone - Website - Face-to-face	
	<b>Cost Structure</b> -----		<b>Revenue Streams</b> -----		

### 2. Toy Company:

Flow Toys bring green energy concepts to life with STEM educational sets, which are designed to help investigate, discuss and evaluate the scientific aspect of renewable energy. Our main goal is to raise awareness as well as knowledge about renewable energy. Moreover, these toys are designed in order to perform the experiment anywhere: at home, schools, parks, etc. These toys are specially designed to address critical STEM engineering concepts of working machines. These kits can also be used in schools allowing students to engage in inquiry-based projects using green energy solutions. Each education kit includes a step-by-step coloured booklet with complete assembly guidelines, which allows the kids to follow easily. You can also bring these toys to the park and enjoy the fascinating process of creation with your family and friends.



<b>The Canvas</b>	<b>Key Partners</b>	<b>Key Activities</b>	<b>Value Propositions</b>	<b>Customer Relationships</b>	<b>Customer Segments</b>
	- Toy company - Shop - Marketing team	- Shop - Experiments at home		- Raise awareness - Raise knowledge - Allow experiment anywhere - Interest in STEM - Teaching about Renewable energy	
		<b>Key Resources</b>		<b>Channels</b>	
		- Research about educational experiments  - Knowledge from the toy company		- Social medias - Advertisements - Toy shops	
<b>Cost Structure</b>			<b>Revenue Streams</b>		
- Research and manufacturing - Publicity			- Education - Fun - Sustainability		

### 3. Mobile application:

The app is a mobile learning platform such as "Duolingo". However, it is a learning platform for science. You are able to go through different levels and subjects personalised on your skills. Daily goals will help you to obtain your aim. Furthermore, its secondary function is an online science library, where you can find all the formulas and short explanations about various scientific topics.

<b>The Canvas</b>	<b>Key Partners</b>	<b>Key Activities</b>	<b>Value Propositions</b>	<b>Customer Relationships</b>	<b>Customer Segments</b>
	- UX designers - Teachers - Science book company	- Design the app - Marketing - Keep the app up-to-date		- Portable science library - Personalized learning	
		<b>Key Resources</b>		<b>Channels</b>	
		- Design team - Educational people - Communicators - The app itself		- Commercials - App store - Website - Social medias	
<b>Cost Structure</b>			<b>Revenue Streams</b>		
- App developing + follow up - Commercials			- Free → in app advertisements - Subscription		

# APPENDIX O

## Moodboard



# Reference list

## 2. PROJECT DEFINITION

- Brown, I., Cools, E., Glowadzka, W., Hopchet, C., Pysson, C., & Sabater, M. (2018). H2OME Final Report Energy Wizards. Antwerpen: University of Antwerp
- Van Moere, J., Ramaekers, B., Chafai, H., Brecht, V., Van Emelen, E., Rafał, M., & Luque, A. (2017). EON Final Report Energy Wizards. Antwerpen: University of Antwerp.

## 3.1. MARKET RESEARCH

- Amazon. (n.d.). Retrieved 2019 from [www.amazon.com](http://www.amazon.com)
- Amazon. (n.d.). Retrieved 2019 from [www.amazon.com](http://www.amazon.com)
- Amazon. (n.d.). Retrieved 2019 from [www.amazon.com](http://www.amazon.com)
- Alternative Energy Tutorials. (n.d.). Retrieved 2019 from [www.alternative-energy-tutorials.com](http://www.alternative-energy-tutorials.com)
- ee publishers. (n.d.). Retrieved 2019 from [www.ee.co.za](http://www.ee.co.za)
- Educational Toys Planet. (n.d.). Retrieved 2019 from [www.educatoysplanet.com](http://www.educatoysplanet.com)
- Electropaedia. (n.d.). Retrieved 2019 from Battery and Energy Technologies:  
[www.mpoweruk.com](http://www.mpoweruk.com)
- Energy gov. (n.d.). Retrieved 2019 from [www.energygov.com](http://www.energygov.com)
- Gigo Toys. (n.d.). Retrieved 2019 from [www.gigotoys.com](http://www.gigotoys.com)

## 3.2. TOPIC RESEARCH

- Renewables first. (n.d.). Retrieved 2019 from [www.renewablesfirst.com](http://www.renewablesfirst.com)
- Renewables first. (n.d.). Retrieved 2019 from [www.renewablesfirst.com](http://www.renewablesfirst.com)
- Renewables first. (n.d.). Retrieved 2019 from [www.renewablesfirst.com](http://www.renewablesfirst.com)



- Science direct. (n.d.). Retrieved 2019 from [www.reader.elsevier.com](http://www.reader.elsevier.com)
- Science direct. (n.d.). Retrieved 2019 from [www.sciencedirect.com](http://www.sciencedirect.com)
- Science direct. (n.d.). Retrieved 2019 from [www.sciencedirect.com](http://www.sciencedirect.com)
- Science direct. (n.d.). Retrieved 2019 from [www.sciencedirect.com](http://www.sciencedirect.com)

### **3.3. CURRICULUM RESEARCH**

- © State of New South Wales, D. o. E., 2019. teaching-stem principles-of-stem-education. [Online] Available at: <http://stem-nsw.com.au/teaching-stem/principles-of-stem-education>
- Anon., 2012. INTERACTIE ET2012. Brugge: Die Keure.

### **3.4 PREVIOUS YEARS**

- Brown, I., Cools, E., Glowadzka, W., Hopchet, C., Pysson, C., & Sabater, M. (2018). H2OME Final Report Energy Wizards. Antwerpen: University of Antwerp
- Van Moere, J., Ramaekers, B., Chafai, H., Brecht, V., Van Emelen, E., Rafał, M., & Luque, A. (2017). EON Final Report Energy Wizards. Antwerpen: University of Antwerp.

### **APPENDIX D. EXTENDED MARKET RESEARCH**

- Amazon. (n.d.). Retrieved 2019 from [www.amazon.com](http://www.amazon.com)
- Amazon. (n.d.). Retrieved 2019 from [www.amazon.com](http://www.amazon.com)
- Amazon. (n.d.). Retrieved 2019 from [www.amazon.com](http://www.amazon.com)
- Alternative Energy Tutorials. (n.d.). Retrieved 2019 from [www.alternative-energy-tutorials.com](http://www.alternative-energy-tutorials.com)
- ee publishers. (n.d.). Retrieved 2019 from [www.ee.co.za](http://www.ee.co.za)
- Educational Toys Planet. (n.d.). Retrieved 2019 from [www.educatoysplanet.com](http://www.educatoysplanet.com)

- Electropaedia. (n.d.). Retrieved 2019 from Battery and Energy Technologies:
- www.mpoweruk.com
- Energy gov. (n.d.). Retrieved 2019 from www.energygov.com
- Gigo Toys. (n.d.). Retrieved 2019 from www.gigotoys.com

## **APPENDIX E. EXTENDED TOPIC RESEARCH**

- Renewables first. (n.d.). Retrieved 2019 from www.renewablesfirst.com
- Renewables first. (n.d.). Retrieved 2019 from www.renewablesfirst.com
- Renewables first. (n.d.). Retrieved 2019 from www.renewablesfirst.com
- Science direct. (n.d.). Retrieved 2019 from www.reader.elsevier.com
- Science direct. (n.d.). Retrieved 2019 from www.sciencedirect.com
- Science direct. (n.d.). Retrieved 2019 from www.sciencedirect.com
- Science direct. (n.d.). Retrieved 2019 from www.sciencedirect.com
- booster, m. (2018). Pelton Turbine Working, Main Parts, Application with Diagram. Retrieved from mechanicalbooster.com:  
<https://www.mechanicalbooster.com/2016/10/pelton-turbine-working-main-parts-application-with-diagram.html>
- dhgate. (2018). Asse verticale 500W 12V / 24V VAWT Helix Generatore eolico Kit generatore basso numero di giri per case. Retrieved from it.dhgate.com: <https://it.dhgate.com/product/500w-12v-24v-vertical-axis-vawt-helix-wind/422782889.html>
- energy, U. d. (2018). Episode 7: From Water to Wattage. Retrieved from energy.gov: <https://www.energy.gov/podcasts/direct-current-energygov-podcast/episode-7-water-wattage>
- Group, R. E. (2018). July 2016 – Laboratory testing of a 3D printed turgo turbine for a 350W pico hydro system. Retrieved from rureg: <https://rurerg.net/2017/12/19/july-2016-laboratory-testing-of-3d-printed-turgo-turbine-for-a-350w-pico-hydro-system/>
- hydropowerplant. (2018). FRANCIS TURBINE. Retrieved from Hydropowerplant: <https://hydropowerplant.com/products/francis-turbines/>

- jumia. (2018). Generic 200 Lt Closed Loop with Blue Selective Collector. Retrieved from [www.jumia.co.ke](http://www.jumia.co.ke):  
<https://www.jumia.co.ke/generic-200-lt-closed-loop-with-blue-selective-collector-147245.html>
- neromylos. (2018). CROSS-FLOW TURBINE. Retrieved from neromylos: <https://www.neromylos.com/en/cross-flow-turbine/>
- solar, c. (2018). evacuated-tubes-10. Retrieved from camel-solar: <http://www.camel-solar.com/cs/evacuated-tubes-10/>
- Tinck. (2018). Tinck engineering building and creating hydro turbines. Retrieved from .hydro-tinck.com: <http://www.hydro-tinck.com/>
- Tripbucker. (2018). see hoover dam nevada. Retrieved from tripbucket: <https://tripbucket.com/dreams/dream/see-hoover-dam-nevada-usa/>
- US, m. c. (2019). What is the most effective and efficient design for a wind generator? Retrieved from medium.com: <https://medium.com/the-future-is-electric/what-is-the-most-effective-and-efficient-design-for-a-wind-generator-6ccf100fc793>

## **APPENDIX G. TECHNOPSIS**

- Mechelen, T. (2018). Facebook Technopolis. Retrieved from Facebook:  
[https://www.facebook.com/pg/Technopolismechelen/photos/?ref=page\\_internal](https://www.facebook.com/pg/Technopolismechelen/photos/?ref=page_internal)
- Technopolis. (2018). Technopolis-visitors. Retrieved from Technopolis: <https://www.technopolis.be/en/visitors/>
- Van Moere, J., Ramaekers, B., Chafai, H., Brecht, V., Van Emelen, E., Rafał, M., & Luque, A. (2017). EON Final Report Energy Wizards. Antwerpen: University of Antwerp.
- vzvzeeland. (2018). vzv zeeland technopolis. Retrieved from vzv zeeland: <https://www.vzvzeeland.nl/en/technopolis-oid339195/>

