



ESCUELA DE INGENIERÍAS  
INDUSTRIALES

**UNIVERSIDAD DE VALLADOLID**

**ESCUELA DE INGENIERIAS INDUSTRIALES**

**Grado en Ingeniería electrónica industrial y automática**

**CONCEPTUAL DESIGN OF AN AUTOMATIC  
SYSTEM FOR FEEDING AND RECEIVING  
SHORT ELEMENTS IN SANDING PROCESSING  
LINE**

**Autor:**

**García del Amo, Alicia**

**Segismundo Samuel Izquierdo Millán**

**University of Applied Sciences in Nysa**

**Valladolid, junio 2021**

**TFG REALIZADO EN PROGRAMA DE INTERCAMBIO**

---

**TÍTULO:** Conceptual design of an automatic system for feeding and receiving short elements in sanding processing line

**ALUMNO:** Alicia García del Amo

**FECHA:** 25 de junio de 2021

**CENTRO:** Faculty of Technical Sciences – Computer Science

**UNIVERSIDAD:** University of Applied Sciences in Nysa

**TUTOR:** Dr. inz. Tomasz Wanat



## RESUMEN, PALABRAS CLAVE

El objetivo del presente Trabajo de Fin de Grado consiste en diseñar conceptualmente un sistema automático utilizando el programa de ordenador Autodesk Inventor 2021, concretamente de un proceso de lijado de láminas cortas de madera. Con este propósito se explican todos los pasos seguidos para el diseño en 3D de cada una de las máquinas presentes como pueden ser transportadores de rodillos, cadenas y cintas o robots manipuladores, así como su funcionamiento y finalidad. Así mismo se explican los componentes cuidadosamente elegidos de diferentes empresas reales que han sido empleados para cumplir todos los requisitos de la línea, concretamente motores, sensores, rodillos, robots, sistemas de agarre por vacío y cilindros neumáticos. El proceso dispone de sensores y actuadores distribuidos a lo largo de todo el recorrido con el fin de garantizar un flujo de materiales unidireccional, constante, funcional, monitorizado y completamente automatizado que logre devolver los materiales de entrada lijados.

Palabras clave: automatización, línea de proceso, máquina, diseño 3D, Inventor.

## ABSTRACT, KEY WORDS

The aim of this Final Degree Project is to conceptually design an automatic system using the Autodesk Inventor 2021 computer programme, specifically a process for sanding short sheets of wood. For this purpose, all the steps followed for the 3D design of each of the machines present, such as roller conveyors, chains and belts or manipulator robots, as well as their operation and purpose, are explained. It also explains the carefully selected components from different real companies that have been placed to meet all the requirements of the line, namely motors, sensors, rollers, robots, vacuum gripping systems and pneumatic cylinders. The process has sensors and actuators distributed along the entire length in order to ensure a unidirectional, constant, functional, monitored and fully automated flow of materials to return the sanded input materials.

Keywords: automation, processing line, machine, 3D design, Inventor.



# PAŃSTWOWA WYŻSZA SZKOŁA ZAWODOWA W NYSIE

University of Applied Sciences in Nysa

Faculty: Technical Sciences

Department: production management and engineering

Specialisation: Automation of production and mechatronic  
systems

Engineering Thesis:

## **CONCEPTUAL DESIGN OF AN AUTOMATIC SYSTEM FOR FEEDING AND RECEIVING SHORT ELEMENTS IN SANDING PROCESSING LINE**

Promotor:

**Dr. inz. Tomasz Wanat**

Autor:

**Alicia García del Amo**

Nysa 2021

## ***ACKNOWLEDGEMENTS***

I would like to thank the help of my tutor in Poland, Dr Tomasz Wanat, for guiding me in the realization of this TFG during my stay in Poland. I would also like to thank my supervisor in Spain, Segismundo Samuel Izquierdo Millán, who solved all my doubts quickly and efficiently. Thanks also to my family, for their unconditional support during the completion of this work despite the distance and throughout my life. And thanks also to all the people who have accompanied me in this Erasmus and who I take with me as friends, who have helped me to disconnect and have encouraged me to continue when I needed it.

To all of them, thank you very much!

## TABLE OF CONTENTS

<b>1. INTRODUCTION</b> .....	<b>1</b>
<b>2. COMPUTER SOFTWARE APPLIED TO ENGINEERING</b> .....	<b>3</b>
<b>3. AUTODESK INVENTOR: THE FUNDAMENTAL TOOL OF THE PROJECT</b> .....	<b>4</b>
3.1. GETTING STARTED WITH AUTODESK INVENTOR .....	5
3.2. FILE CREATION .....	8
3.2.1. <i>PIECE FILES (.ipt)</i> .....	8
3.2.2. <i>ASSEMBLY FILES (.iam)</i> .....	10
3.2.3. <i>PRESENTATION FILES (.ipn)</i> .....	12
3.2.4. <i>DRAWING FILES (.idw, .dwg)</i> .....	12
<b>4. OBJECTIVES AND ASSUMPTIONS ADOPTED</b> .....	<b>14</b>
4.1 PROJECT OBJECTIVES .....	14
4.2. ASSUMPTIONS MADE .....	14
<b>5. GENERAL DESCRIPTION OF THE LINE</b> .....	<b>17</b>
5.1. PROJECT DEVELOPMENT .....	17
5.2. GENERAL VIEW OF THE OPERATION OF THE LINE .....	17
<b>6. COMPONENT SUPPLIERS</b> .....	<b>24</b>
<i>MÄDLER GMBH</i> .....	25
<i>SMC GmbH</i> .....	26
<i>HIWIN GmbH</i> .....	26
<i>ABB</i> .....	26
<i>SICK</i> .....	27
<i>AB SKF</i> .....	27
<i>TECHNIK CNC</i> .....	28
<i>NORD</i> .....	28
<i>FAMAD SP. Z o.o.</i> .....	29
<i>COSTA LEVIGATRICI S.p.A.</i> .....	29
<i>PIAB AB AND KENOS</i> .....	30
<i>SEW WURODRIVE GmbH &amp; CO KG</i> .....	31
<b>7. CHAIN CONVEYOR FOR THE PALLETS</b> .....	<b>32</b>
7.1. INDIVIDUAL CHAIN CONVEYOR .....	33
7.1.1 <i>CREATION OF THE CHAIN AND SPROCKETS</i> .....	34
7.2. MOTORS, SHAFT AND BALL BEARING WITH OVAL FLANGE .....	41
7.2.1. <i>PRELIMINARY CALCULATIONS FOR THE MOTORS</i> .....	41
7.2.2 <i>CHOICE OF MOTORS</i> .....	43
7.2.3. <i>MOTOR SHAFT</i> .....	46
7.2.4. <i>BALL BEARING WITH OVAL FLANGE</i> .....	46
7.3. CHAIN CONVEYOR STRUCTURE .....	48
7.4. CHAIN CONVEYOR SENSORS.....	49
7.4.1. <i>ELECTION OF THE SENSORS</i> .....	49
7.4.2. <i>FIXING PART OF THE SENSOR</i> .....	51
7.4.3. <i>SENSOR ASSEMBLY AND MOUNTING SYSTEM</i> .....	53
7.4.4. <i>PLACEMENT OF THE SENSOR ON THE CHAIN CONVEYOR</i> .....	53
7.5. INDIVIDUAL CHAIN CONVEYOR .....	54
7.6. CHAIN CONVEYOR ON THE LINE .....	55

<b>8. CHAIN ROLLER ON LIFTING TABLE .....</b>	<b>56</b>
8.1. CHAIN ROLLER .....	57
8.2. LIFTING TABLE .....	58
8.3. STOPPERS .....	59
8.3.1. PNEUMATIC CYLINDERS.....	60
8.3.2. MOUNTING PART.....	64
8.3.3. ELEMENTS THAT STOP THE PALLET .....	65
8.4. SENSORS.....	65
8.4.1. SENSOR FOR DETECTING THE HEIGHT AT WHICH THE TABLE IS POSITIONED.....	66
8.4.2. SENSORS FOR DETECTING THE PRESENCE OF WOODEN SLATS ON THE PALLET .....	69
8.4.3. SENSORS FOR DETECTING THE MATERIAL INFEEED AND OUTFEED OF THE MACHINE .....	74
8.4.4. MAGNETIC SENSORS FOR DETECTING THE CYLINDER POSITION.....	74
<b>9. ROBOT WITH VACUUM SYSTEM.....</b>	<b>75</b>
9.1. ROBOT IRB 760 .....	75
9.2. VACUUM GRIPPERS .....	78
9.3. CONNECTING STRUCTURE OF THE ROBOT AND THE VACUUM GRIPPING SYSTEMS.....	81
9.4. TABLE FOR THE ROBOT .....	82
9.5. ROBOT WITH VACUUM GRIPPERS IN THE LINE .....	83
<b>10. ROLLER CONVEYOR BEFORE GRINDING MACHINE.....</b>	<b>84</b>
10.1. ROLLERS.....	84
10.2. MOTOR .....	87
10.3. STRUCTURE OF THE ROLLER CONVEYOR .....	90
10.4. SENSORS.....	92
10.5. ROLLER CONVEYOR IN THE LINE .....	93
<b>11. CALIBRATING SANDING MACHINE .....</b>	<b>94</b>
<b>12. ROLLER AND BELT CONVEYOR AFTER SANDING MACHINE .....</b>	<b>99</b>
12.1. ROLLER CONVEYOR .....	100
12.2. STRUCTURE TO SUPPORT TWO ROLLER CONVEYORS.....	103
12.2.1. MAIN STRUCTURE.....	103
12.2.2. CYLINDERS.....	104
12.3. BELT CONVEYOR .....	106
12.3.1. BELT ARMS.....	106
12.3.2. MOTOR .....	110
12.3.3. STRUCTURE THAT HOLDS THE BELT CONVEYOR.....	111
12.4. STOPPERS .....	112
12.4.1 STOPPERS IN THE ROLLER CONVEYOR .....	112
12.4.2. STOPPERS IN THE BELT CONVEYOR .....	113
12.5. SENSORS.....	114
12.5.1. SENSORS IN THE ROLLER CONVEYOR.....	114
12.5.2. SENSORS IN THE BELT CONVEYOR .....	115
12.6. BELT AND ROLLER CONVEYOR IN THE LINE .....	116
<b>13. ROBOT WITH MOVING VACUUM GRIPPING SYSTEM .....</b>	<b>116</b>
13.1. LINEAR GUIDEWAYS .....	117
13.2. CYLINDERS THAT MOVE THE LINEAR GUIDEWAYS.....	123
13.3. ROBOT WITH MOVING VACUUM GRIPPERS IN THE LINE .....	125
<b>14. ROLLER CONVEYORS FOR THE PALLETS .....</b>	<b>126</b>

14.1. ROLLERS.....	126
14.2. MOTOR.....	129
14.3. GENERAL STRUCTURE.....	129
14.4. SENSORS.....	131
14.5. ROLLER CONVEYORS THAT TRANSPORT PALLETS IN THE LINE.....	131
<b>15. ROLLER AND CHAIN CONVEYORS .....</b>	<b>132</b>
15.1. CHAIN CONVEYORS .....	135
15.2. ROLLER CONVEYORS.....	138
15.2.1. <i>FIRST ROLLER CONVEYOR</i> .....	139
15.2.2. <i>SECOND ROLLER CONVEYOR</i> .....	140
15.2.3. <i>THIRD ROLLER CONVEYOR</i> .....	142
15.2.4. <i>FOURTH ROLLER CONVEYOR</i> .....	142
<b>16. LINE PROTECTION FENCES.....</b>	<b>143</b>
<b>REFERENCES.....</b>	<b>146</b>
<b>BIBLIOGRAPHY.....</b>	<b>149</b>
<b>ANNEX I: DRAWING OF MACHINES DESIGNED WITH AUTODESK INVENTOR 2021 .....</b>	<b>150</b>
<b>ANNEX 2. DATASHEET OF THE COMPONENTS LOCATED ON THE LINE PROVIDED BY COMPANIES .....</b>	<b>164</b>

## TABLE OF FIGURES AND CHARTS

<i>Figure 1.1. Automatic system for sanding short wooden elements designed by me in this project</i> .....	2
<i>Figure 3.1. Starting page of Autodesk Inventor Professional 2021.</i> .....	5
<i>Figure 3.2. Window in Autodesk Inventor for selecting the type of project to be created.</i> .....	6
<i>Figure 3.3. Window in Autodesk Inventor where the user selects the name and location of the new project</i> .....	6
<i>Figure 3.4. Window in Autodesk Inventor where the libraries for the new project are chosen</i> .....	7
<i>Figure 3.5. Window used to move a file and associated files from one project to another in Autodesk Inventor.</i> .....	7
<i>Figure 3.6. Window in Autodesk Inventor for creating a new file.</i> .....	8
<i>Figure 3.7. Example of a part file in Autodesk Inventor</i> .....	9
<i>Figure 3.8. Example of a Sheet Metal.ipt in Autodesk Inventor.</i> .....	9
<i>Figure 3.9. Window of application options in Autodesk Inventor</i> .....	10
<i>Figure 3.10. Plane in part file .ipt.</i> .....	11
<i>Figure 3.11. Same plane as before with machining operations in assembly file .iam.</i> .....	11
<i>Figure 3.12. Window of the Autodesk Inventor Content Centre</i> .....	12
<i>Figure 3.13. Example of a drawing file that is attached to annex 2.</i> .....	13
<i>Figure 4.1. Short wooden elements that enter in the line together.</i> .....	14
<i>Figure 4.2. Wooden pallet with standardized dimensions.</i> .....	15
<i>Figure 4.3. Pallet with 20 wooden elements on it.</i> .....	16
<i>Figure 5.1. Automatic system of sanding wooden pieces. The numbers correspond to Chart 5.1</i> .....	18
<i>Chart 5.1. Relation between the numbers written in Figure 5.1 and the name of that machines.</i> .....	18
<i>Figure 5.2. View of the system from the entrance of material</i> .....	19
<i>Figure 5.3. Wooden elements entering in the sanding machine by the roller conveyor.</i> .....	20
<i>Figure 5.4. Image from the wooden sheets going out of the sanding machines to the belt roller conveyor.</i> .....	21
<i>Figure 5.5. Robot that puts the wood sheets together with the vacuum gripping systems.</i> .....	21
<i>Figure 5.6. Double chain conveyors that transport the pallets under the roller conveyor.</i> .....	22
<i>Figure 5.7. Roller conveyors that transport the pallets.</i> .....	22
<i>Figure 5.8. Single chain conveyors that transport the pallets.</i> .....	23
<i>Figure 5.9. Image of the pallets in the last part of the system.</i> .....	24
<i>Figure 6.1. Logotypes of the enterprises producing machine components and equipment related to automatization used in the project.</i> .....	25
<i>Figure 7.1. Chain conveyor for transporting the pallets.</i> .....	32
<i>Figure 7.2. Chains used in the chain conveyor</i> .....	33
<i>Figure 7.3. Rectangular tube with dimensions, used in chain structure and taken from Content Centre.</i> .	33
<i>Figure 7.4. Screenshot on Autodesk Inventor on how to select a sprocket and create a chain.</i> .....	34
<i>Figure 7.5. Characteristics of a sprocket 10B-2-58 with 19 teeth</i> .....	35
<i>Figure 7.6. Chain created in Autodesk Inventor with 19 teeth.</i> .....	35
<i>Figure 7.7. Technical data of the chain wheel 10B-2-z19 from website TECHNIK CNC.</i> .....	36
<i>Figure 7.8. Sprocket edited as the ones available in the market and used in the chain conveyors.</i> .....	36
<i>Figure 7.9. Cut view of the final chain with sprockets inside the structure.</i> .....	37
<i>Figure 7.10. Deep groove ball bearing placed inside the sprocket.</i> .....	37
<i>Figure 7.11. Clamping piece introduced inside the deep groove ball bearings.</i> .....	38
<i>Figure 7.12. Part in the side of the chain transporter</i> .....	39
<i>Figure 7.13. Profile of the guideline type T2 of the chain.</i> .....	39
<i>Figure 7.14. Dimensions of the guideline of the chains.</i> .....	40
<i>Figure 7.15. Half view of frontal side and full view back side of the central part of the chains where the power is transmitted.</i> .....	40
<i>Figure 7.16. Protection part of the three sprockets situated in the biggest plane in the chain</i> .....	41

Figure 7.17. On the left, a picture of the motor Worm Gears UNIVERSAL SI. On the left, the pieces that form that motor.....	44
Figure 7.18. CAD drawing of the motor Worm Gears UNIVERSAL SI, SK 1SI63 - IEC80 - 80LP/4 B14 C120. ....	44
Figure 7.19. Axis that connects the motor and three chain sprockets.....	46
Chart 7.1. General information about the FYTJ 30 TF oval flanged ball bearing.....	47
Figure 7.20. Comparison between a real FYTJ 30 TF Oval flanged ball bearing units and the CAD drawing. ....	47
Figure 7.21. FYTJ 30 TF Oval flanged ball bearing in the assembly. ....	47
Figure 7.22. Structure that holds and fixes the chains to the main structure.....	48
Figure 7.23. Group of components that join the structure with the floor. ....	48
Figure 7.24. Small photoelectric sensor WL12-3V2431 from the company SICK.....	50
Chart 7.5. Detailed technical data provided about the photoelectric sensor WL12-3V2431 from the company SICK. ....	50
Figure 7.25. Dimensional drawing of the sensor WL12-3V2431 from the company SICK. Dimensions in mm (inch).....	51
Figure 7.26. Picture of the mounting system type BEF-WG-W12. ....	51
Chart 7.7. Technical specifications of the mounting system type BEF-WG-W12.....	52
Figure 7.27. Dimensional drawing of the mounting system type BEF-WG-W12. Dimensions in mm (inch). ....	52
Figure 7.28. Assembly of the sensor and the mounting system seem from opposite corners.....	53
Figure 7.29. Position of a sensor in the chain conveyor.....	54
Figure 7.30. Roller conveyor with only one flow of pallets. Dimensions in mm.....	54
Figure 7.31. Image of the two existing conveyors at the beginning of the line.....	55
Figure 7.32. Roller conveyor that takes the pallets with full load out of the line. ....	55
Figure 7.33. Location of the chain conveyors that transport one flow of pallets in the line.....	56
Figure 8.1. Machine consisting of a chain roller on a lifting table.....	57
Chart 8.1. Technical data of the scissors lift DBNA - 2,5 t. ....	58
Figure 8.2. CAD Drawing of the scissor lift DBNA – 2.5 t. ....	59
Figure 8.2. Structure of the stoppers of the pallets with material.....	60
Figure 8.3. Parameters of the Compact Guide Cylinder MGPM80TF-30Z for the stoppers in the lifting table.....	61
Figure 8.4. Scheme explaining the name of this type of cylinder in the company SMC.....	61
Figure 8.5. Imagen of a real pneumatic compact guide cylinder MGPM80TF-30Z. ....	62
Figure 8.6. pneumatic compact guide cylinder MGPM80TF-30Z with two switches.....	63
Figure 8.7. On the left, moving part of the cylinder. On the right side, half view of the still part of the cylinder. The arrows indicate the surfaces which should be selected for applying the constraint with movement.....	63
Figure 8.8. Window for placing constraint where the restriction of movement has a maximum and a minimum. ....	64
Figure 8.9. Green mounting plane of the cylinder with bolts. ....	64
Figure 8.10. Structure that stops the pallets with material which is attached to the cylinder. ....	65
Chart 8.2. Technical data specification of the wire draw encoder EcoLine, type BCG08-P1BM0336. ....	67
Figure 8.11. Dimensional drawing of the wire draw encoder EcoLine, type BCG08-P1BM0336. Dimensions in mm (inch). ....	67
Figure 8.12. Real image of a wire draw encoder EcoLine, type BCG08-P1BM0336. ....	68
Figure 8.13. Sensor with fixing part, on the left view form the from and on the right opposite side with measurements.....	68
Figure 8.14. wire draw encoder EcoLine, type BCG08-P1BM0336 under the lifting table.....	69
Figure 8.15. Real picture of the fiber-optic sensor GLL170T-B434.....	70
Chart 8.3. Technical details of the fibre optic sensor GLL170T-B434.....	70
Figure 8.16. Dimensional drawing of the fiber-optic sensor GLL170T-B434. Dimensions in mm (inch). ....	71



Figure 8.17. Mounting system BEF-WLL180 suitable for fibre-optic sensor type GLL170. ....	71
Figure 8.18. Dimensional drawing in mm (inch) of the mounting system BEF-WLL180. ....	72
Figure 8.19. On the left, fibre-optic sensor on its structure. On the right, image of the full structure with dimensions in mm. Drawings from Autodesk Inventor. ....	72
Figure 8.20. Fiber-optic sensors in the line detecting the wood sheets on the pallets on the chain conveyor on the lifting table. ....	73
Figure 8.21. Two pieces of M9B--Solid State, Gen. Purpose, 2 Wire, Horizontal in cylinder. ....	74
Figure 9.1. Real image of the IRB 760 robot. ....	75
Figure 9.2. Working range and dimensions of the robot IRB 760. ....	76
Chart 8.9. Specification of the IRB 760 robot. ....	77
Figure 9.3. IRB 760 robot, CAD drawing in Autodesk Inventor, views from to opposite sides. ....	77
Figure 9.4. Construction scheme of KENOS KVG series vacuum gripping system. ....	78
Chart 9.2. Technical data of KENOS KVG120 vacuum gripping system. ....	79
Figure 9.5. Dimensional drawing of KENOS KVG120 vacuum gripping system. Dimensions in mm (inch). ....	80
Figure 9.6. Pneumatical diagram of KENOS KVG120 vacuum gripping system. ....	80
Figure 9.7. Image of the 3D CAD drawing of KENOS KVG120 vacuum gripping system in Autodesk Inventor. ....	80
Figure 9.8. 3D drawing of a DIN 188 bolt in Autodesk Inventor. ....	81
Figure 9.9. Structure with to vacuum grippers that joins them with the IRB 760 robot. Dimensions in mm. ....	82
Figure 9.10. Image of the table that elevates the robot with dimensions (mm). ....	83
Figure 9.11. The IRB robot with the vacuum grippers on a table located in the line. ....	83
Figure 10.1. Roller conveyor before grinding machine in Autodesk Inventor. ....	84
Chart 10.1. Technical data of the heavy-duty conveyor roller series 3560 of Interroll. ....	85
Chart 10.2. Maximum load capacity of the heavy-duty conveyor roller series 3560 depending on the length. ....	86
Figure 10.2. Dimensional drawing of the heavy-duty conveyor roller series 3560 in mm. ....	86
Figure 20.3. 3D image of the heavy-duty conveyor roller series 3560 in Autodesk Inventor with dimensions in mm. ....	87
Figure 10.4. Basic structure of helical gear units R of the company SEW. ....	88
Figure 10.5. Perspective, frontal and side views of the R..DR.. helical gearmotor in foot-mounted design. ....	88
Chart 10.3. Technical data of the SEW helical gearmotor R17DRN80M4. ....	89
Figure 10.5. Image of the helical gear motor R17DRN80M4 in Autodesk Inventor with dimensions in mm. ....	90
Figure 10.6. Chains that connect the rollers between them and with the motor in the roller conveyor. ....	90
Figure 10.7. Plane that fixes the motor to the main structure in the roller conveyor with dimensions in mm. ....	91
Figure 10.8. Piece that holds the roller by each side in the roller conveyor. ....	91
Figure 10.9. Parts resting on the floor on roller conveyors with dimensions in mm. ....	92
Figure 10.10. WL12-3V2431 photocell from SICK on a square tube with the length in mm. ....	93
Figure 10.11. Roller conveyor on the line transporting wood sheets in groups of 14 elements. ....	93
Figure 11.1. Calibrating sanding machine series K, company Costa Levigatrici. ....	94
Figure 11.2. Inside view of the Series K calibrating sanding machine of the company Costa Levigatrici. ....	95
Figure 11.3. Scheme on how the Costa Levigatrici Series K calibrating sanding machine works. ....	95
Figure 11.4. Automatic centering system of the wood sheets in the Series K calibrating sanding machine by Costa Levigatrici. ....	96
Figure 11.5. Scheme of how the automatic feed speed control system works in a Series K calibrating sanding machine of Costa Levigatrici. ....	96
Figure 11.6. Example of what can be seen in the screen of the PLC in the Costa Levigatrici Series 6 calibrating sanding machines. ....	97
Figure 11.7. Drawing of selective air jet blowers in Costa Levigatrici machines. ....	97

Figure 11.8. Efficient centralized dust connector in Costa Levigatrici calibrating-sanding machines. ....	98
Figure 11.9. Explanation how the PLC height control process works in the Costa Levigatrici Series 6 calibrating sanding machine. ....	99
Figure 12.1. Belt roller conveyor with dimensions in mm. ....	100
Figure 12.2. Close view of the way of transmitting the movement from the motor to the rollers with chains. ....	101
Figure 12.3. Roller conveyor after sanding machine with dimensions in mm. ....	102
Figure 12.4. Structure that holds the two roller conveyors. ....	103
Figure 12.5. Views of the MGPM80TF-30Z-M9B cylinder with the bore side of 80 mm. ....	104
Figure 12.6. Image of the MGPM80TF-30Z-M9B cylinder with the bore side of 80 mm, on the left the full view of the cylinder, on the right, half view of it with dimensions in mm. ....	105
Figure 12.7. Structure that connects the cylinders with the main structure that rests in the floor and with the chain conveyor. Dimensions in mm. ....	105
Figure 12.8. Close view of one of the four cylinders that lift the moving roller conveyor. ....	106
Figure 12.9. Window of Synchronous Belts Component Generator in Autodesk Inventor. ....	107
Figure 12.11. Shape and dimensions of the pulley 25-T10-32. ....	108
Figure 12.12. Pulley 25-T10-32 with 32 teeth in Autodesk Inventor. ....	108
Figure 12.13. Guideline of the belt 25-T10. Dimensions in mm. ....	108
Figure 12.14. Structure that holds the belt arm with dimensions in mm. ....	109
Figure 12.15. Structure on one of the sides of the belt arm. ....	109
Figure 12.16. Structure on the side to support the axis that connects to the motor and transmits the movement. Dimensions in mm. ....	110
Figure 12.17. Gearmotor R07DRN80M4 located in the belt conveyor. Dimensions in mm. ....	111
Figure 12.18. Structure situated in the extremes of the belt arms that holds them. ....	111
Figure 12.19. Moving stopper in the roller and belt conveyor after sanding machine. ....	113
Figure 12.20. Still stoppers in the end of the belt conveyor. Dimensions in mm. ....	113
Figure 12.21. View of the position of the sensors from the top in each roller and belt conveyor. ....	115
Figure 12.22. View from the top of the four photocell sensors located in each belt conveyor. ....	115
Figure 12.23. Both roller and belt conveyors in the line with wooden sheets on them. ....	116
Figure 13.1. Image of the structure that joins the robot with the vacuum grippers. ....	117
Figure 13.2. Image of the elements of series HG HIWIN Lineal guideway block. ....	118
Figure 13.3. Scheme of a T-rail/Mounting from below. ....	119
Figure 13.4. Technical data and model number for coatings of HIWIN Coating HICOAT CZS. ....	120
Figure 13.5. Image of lineal guideway HGH20CA of HIWIN. ....	120
Figure 13.6. Dimensional drawing of lineal guideway HGH20CA of HIWIN. Dimensions in mm. ....	121
Figure 13.7. Moments of the block of HGH20CA2T1400Z0H+CZS by the company HIWIN. ....	121
Figure 13.8. Dimensional drawing of the rail of the HGH20CA2T1400Z0H+CZS by the company HIWIN. ....	122
Figure 13.9. CAD drawing in Autodesk Inventor of the assembly block + rail of a lineal guideway HGH20CA2T1400Z0H+CZS by the company HIWIN. ....	122
Figure 13.10. Image on Autodesk Inventor of four blocks of lineal guideways joined by a plane. Dimensions in mm. ....	123
Figure 13.11. CAD drawings in Autodesk Inventor of the MGPL50TF-100Z-M9B cylinder up and down. Dimensions in mm. ....	124
Figure 13.13. Structure of the MGPL50TF-100Z-M9B cylinder joined to the structure of the robot. Dimensions in mm. ....	125
Figure 13.14. Robot that takes two rows of fourteen wooden sheets and puts them together working in the line. ....	125
Figure 14.1. Roller conveyor for transporting the pallets, with dimensions in mm. ....	126
Chart 14.1. Technical data of the heavy-duty conveyor roller Series 3600 from Interroll. ....	127
Figure 14.2. Parameters chosen for the heavy-duty conveyor roller Series 3600 from Interroll. ....	127
Chart 14.2. Force each heavy-duty conveyor roller Series 3600 from Interroll can stand according to its length. ....	128

Figure 14.3. Dimensions of the heavy-duty conveyor roller Series 3600 from Interroll. ....	128
Figure 14.4. CAD drawing in Autodesk Inventor of the heavy-duty conveyor roller Series 3600 from Interroll. Dimensions in mm. ....	129
Figure 14.5. Legs of the roller conveyor that transports empty pallets. Dimensions in mm. ....	130
Figure 14.6. Protective component of the sprockets of the rollers. ....	130
Figure 14.7. Close view of a WL12-3V2431 photocell from SICK, located in the roller conveyor to detect the presence of pallets on the it. ....	131
Figure 14.8. The three roller conveyors transporting pallets in the line. ....	132
Figure 15.1. First roller chain conveyor that transports pallets. Dimensions in mm. ....	133
Figure 15.2. Second chain roller conveyor transporting pallets. Dimensions in mm. ....	133
Figure 15.3. Third chain roller conveyor transporting pallets. Dimensions in mm. ....	134
Figure 15.4. Fourth chain roller conveyor transporting pallets. Dimensions in mm. ....	134
Figure 15.5. Image of Compact Cylinder – CQ2-Z from the company SMC. ....	135
Figure 15.6. Parameters chosen for the Compact Cylinder – CQ2-Z from the company SMC. ....	136
Figure 15.7. Explanation of the name of the Compact cylinder CDQ2 with auto switch. ....	136
Figure 15.8. Drawing and chart explaining the component parts of the compact cylinder CDQ2 and its materials. ....	137
Figure 15.9. Dimensions of the cylinder Compact cylinder CDQ2 with auto switch. ....	137
Figure 15.10. Views from the front and the back of the structure of the cylinders that lift the chain conveyors. Dimensions in mm. ....	138
Figure 15.11. First roller conveyor of the chain roller conveyor machine that transports pallets. Dimensions in mm. ....	139
Figure 15.12. Still stoppers for the pallets in the first roller conveyor. Dimensions in mm. ....	140
Figure 15.13. Still stopper in the roller conveyor part of the chain roller conveyor that transports pallets. Dimensions in mm. ....	141
Figure 15.14. Second roller conveyor of the chain roller conveyor machine that transports pallets. Dimensions in mm. ....	141
Figure 15.15. Second roller conveyor of the chain roller conveyor machine that transports pallets. Dimensions in mm. ....	142
Figure 15.16. Moving stopper of the fourth chain roller conveyor. ....	143
Figure 16.1. Elementary panel that forms the structure of the surrounding protection fences. Dimensions in mm. ....	144
Figure 16.2. Vertical structure that holds the fences surrounding the line with zoom in the joining pieces. Dimensions in mm. ....	144
Figure 16.3. Different standing structures to hold the pallets. On the left, it holds to panels in the same plane. In the middle, it is situated in a corner. On the right, it is situated in the end of a row. Dimensions in mm. ....	145
Figure 16.4. General view of the surrounding protection fences in the production line. ....	145

## 1. INTRODUCTION

Woodworking in Poland is one of the most promising and fastest growing sectors of the national economy. Most of the sector's products in the country are furniture, doors and windows made of wood, which account for a large volume of exports worldwide.

Furniture is one of the most dynamic sectors of industry in Poland, where manufacturers strive to adapt to a competitive market and its development, demonstrating their ability to adapt over the years. Currently, it is positioned in the leadership of the world furniture trade, and growth continues to be positive. This is due, among other reasons, to a good workforce, specialization, low production costs, proximity and wealth of wood and its derivatives, good location within the European West and long experience in the sector, seeking to continuously meet the technical requirements and high quality and design demanded in these markets. Therefore, there is a rapid development and investment in the factories of this product, resulting in an improvement of the production lines, and consequently, a constant introduction of new technologies that promote automation.

Industrial automation consists of the use of electromechanical machines of industrial robotics or computer systems, which perform the processes of a company automatically and autonomously. Automating a process allows the control and monitoring of production systems through digital technologies. This came with Industry 4.0 where human operators are replaced by an automatic machine, robot or software. The process allows to reduce cycle times, increase productivity and quality of the process and improve the competitiveness of companies, a key point of an efficient and competitive industry.

The process that concerns the project is an automated production system, where human intervention is not necessary because everything is controlled by a computer system that receives information from sensors and transmits it to the actuators.

The advantages of automation are, among others:

- Improved efficiency of the production process.
- Improves product quality by reducing the number of errors and increasing precision.
- Increases the productivity of the company since the execution time is reduced.
- Costs are reduced by reducing the number of personnel required.
- Increases the competitiveness of the company in the market.
- Improves the management and logistic control of materials and elements of the production process.
- Stress, fatigue and, consequently, accidents at work are reduced, as people are replaced by machines in the most dangerous or monotonous jobs.

However, the adaptation of this technology also presents a series of disadvantages:

- High initial investment.
- Frequent and strict control of the maintenance of industrial automation systems.
- Loss of employment in the social aspect, as people are replaced by machines.
- Difficulty of flexibility when adapting the machines to different jobs.

Every day more and more companies understand the usefulness of this industrial automation and introduce it in their factories, improving the process and obtaining results of higher quality, while the technology of automated machines and software programs control what happens in a large number of manufacturing processes. All these tools allow the wood market in Poland to continue to grow in the 21st century despite the large number of new materials and products that have been introduced in the market in recent years. Not only the enterprises related to this sector, but more and more companies are implementing these technologies recently and obtaining profitable results.

The designed automated line that will be explained throughout this project can be seen in Figure 1.1.

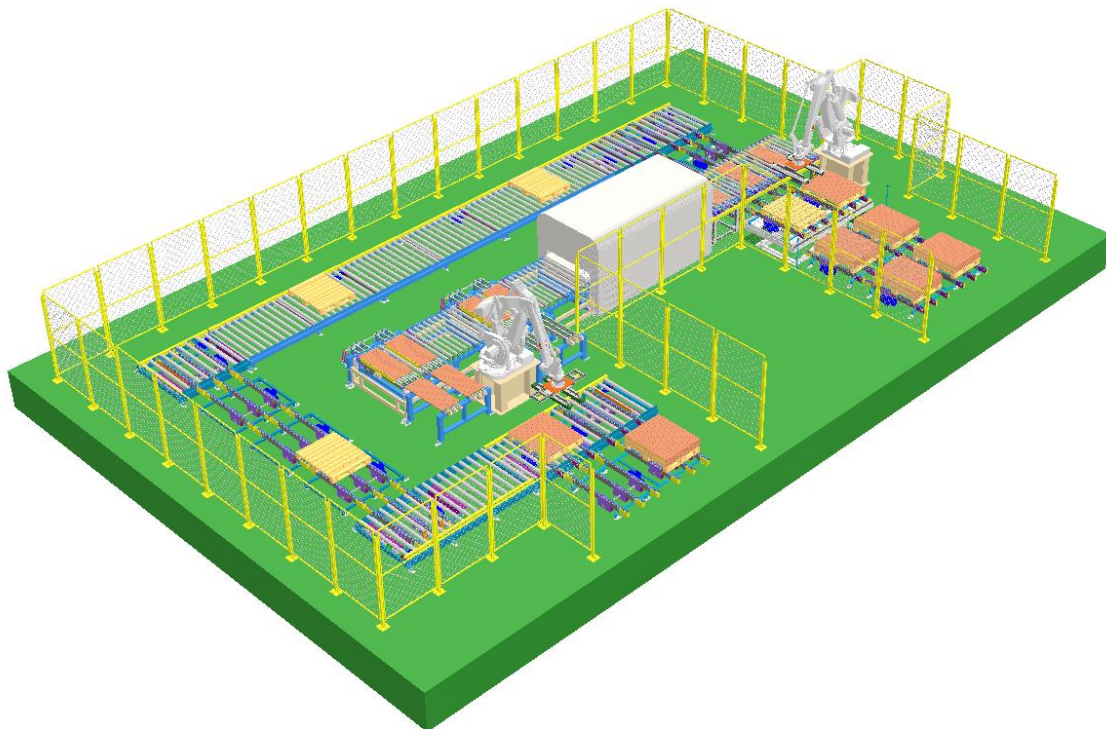

*Figure 1.1. Automatic system for sanding short wooden elements designed by me in this project.*

## 2. COMPUTER SOFTWARE APPLIED TO ENGINEERING

All technological advances applied in a company go through numerous phases in which computer software plays a fundamental role. Engineers stopped sketching by hand some time ago and started using different programs that facilitate the work prior to the implementation of machines in a company, allowing to evaluate different options before putting them into practice. A large number of resources can be found on the web, which leads to the need to distinguish the different types of software and their functionalities.

- CAD or Computer Aided Design allows the design of elements through the computer in an interactive and dynamic way. It is also possible to assemble different components, study their interactions, and subsequently create drawings of the assembly and the part, which greatly facilitates production. This software is used in fields as wide-ranging as mechanics to design machines, in electricity to create connection diagrams, and in civil engineering to design structures.

There are three types of CAD:

- 2D CAD, for two-dimensional technical drawings, creating flat drawings of products or structures from various types of geometric lines and shapes. This type includes AutoCAD, CATIA v4, CADkey or Medusa programs.
  - 2 ½ CAD, an extension of 2D that includes some two-dimensional features, i.e. prismatic drawings, which show depth.
  - 3D CAD, which allows the handling of complete three-dimensional technical drawings. A realistic sample of the object to be designed is created, allowing errors to be detected more quickly and reducing production costs. Examples of this software are SOLIDWORKS, Unigraphics NX, CoCreate Solid Design and Autodesk Inventor, among others. The latter will be the one used in this project and will be discussed in more detail later.
- CAM or Computer Aided Manufacturing. Once the CAD model has been made, this is the next phase, where we work in a more manufacturing-oriented way, since the aim is to obtain the model from a metal cube after performing different operations. In short, it is about obtaining the CNC code for the machine to perform the operations automatically. Some examples of this software are Catia, SolidWorks, NX, etc.
  - CAE or Computer Aided Engineering. It consists of the analysis of the CAD model focusing it from the profitability, manufacturing feasibility, simulation, to check if the created product could have a place in the market of the moment. ANSYS, ABAQUS or NASTRAN software stand out.

### 3. AUTODESK INVENTOR: THE FUNDAMENTAL TOOL OF THE PROJECT

For the design of the automatic feeding and receiving system of the elements in the sanding processing line, constant use has been made of one of the best-known CAD software for assisted design: Autodesk Inventor Professional.

Autodesk Inventor is a design software application for solid modelling, intended for the creation of 3D digital prototypes for product design, visualization and simulation, as well as the creation of related documents, through professional tools. It is an efficient way of working combining standardized, parametric, direct and free-form design functions. Its origin is due to the software company Autodesk, which initially started creating a parametric 3D solid modelling package.

Autodesk Inventor stands out from other CAD programs for several reasons, most notably:

- Belonging to the Autodesk group, allowing to use AutoCAD drawings as sketches in Autodesk Inventor, so users of this other tool will find it very useful due to its compatibility.
- The design interface is easy to understand, intuitive and dynamic, so starting to work with it from scratch without knowing it will not be a hard task.
- 3D models can be published on the Web, allowing them to be viewed remotely. This facilitates the realization of a project by several people or concurrently, due to it has collaboration tools integrated with design reviews in the cloud. There is even the possibility of requesting feedback from a customer who can view the project without having the Autodesk Inventor program installed.
- Tools capable of optimizing quality, time and cost in product manufacturing.
- Simple and quick modification of assemblies with iLogic technology.

In this project we have used the version of Autodesk Inventor Professional 2021, the most recent so far and with all the functions created up to the present day.



## 3.1. GETTING STARTED WITH AUTODESK INVENTOR

The first thing to do in order to start working with Inventor and design any component is to create a project. To do this, it is necessary to know the layout of the different options of the program. Once initialized, a screen similar to the one shown in Figure 3.1 appears.

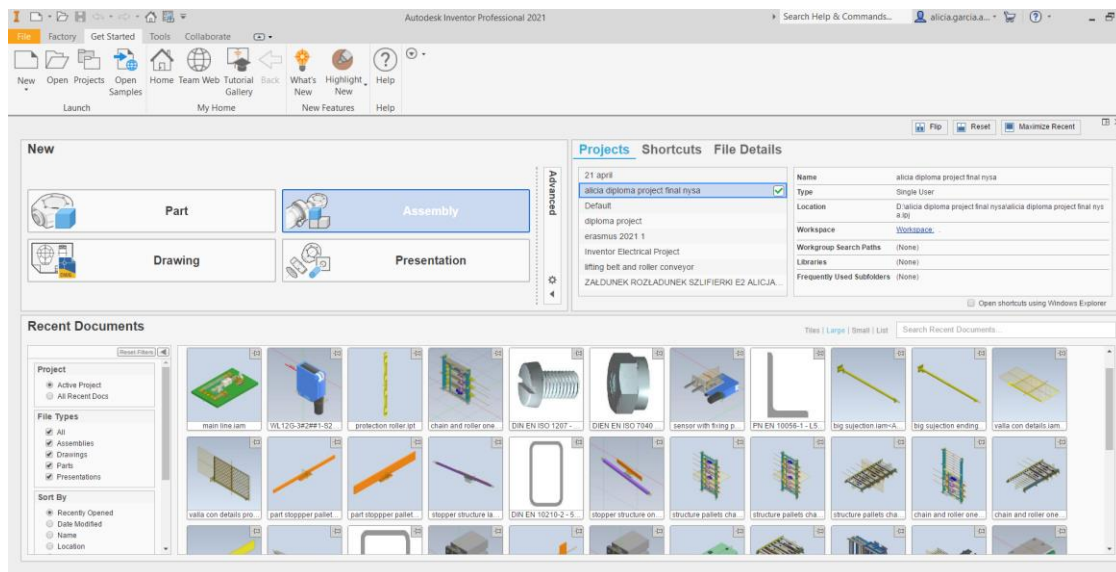

Figure 3.1. Starting page of Autodesk Inventor Professional 2021.

At the top is the toolbar. Below it on the left are the different options with which you can start working. To the right of it you can see the projects part: in the program on my computer there are different projects created and one of them is selected, highlighted in blue and with a tick. This means that this is the currently active project. Underneath you can see the different files that have been used most recently, which allows quick access to them once you have logged out and logged back in.

In case you do not have any project created, which happens when you use the program for the first time, you need to create a new one. To do this you need to select the Projects section, third option starting from the left of the upper toolbar, as shown in Figure 3.1. Then click on New New Single User Project. If the project is to be used remotely, New Vault Project would be selected instead of this option, but this is not the case. These options are shown in Figure 3.2.



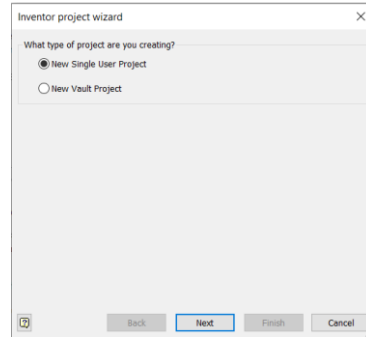

Figure 3.2. Window in Autodesk Inventor for selecting the type of project to be created.

After that, choose a name and the location where you want to save the project on your computer in the window shown in Figure 3.3.

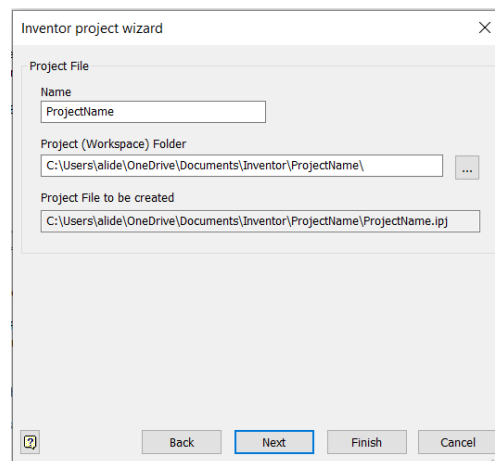

Figure 3.3. Window in Autodesk Inventor where the user selects the name and location of the new project

Finally, the libraries must be selected. It is important to choose the libraries well, since in the creation of assemblies you can save a lot of time if you already have structures and certain elements, such as screws and nuts that have already been created. Autodesk has a large library of standardized elements that can easily be incorporated into assemblies. The elements are standardized according to standards: ANSI, ISO, DIN, BSI, GB, GOST and JIS. Libraries can be modified or new ones can be created to speed up the process of inserting the users own parts into assemblies. Once the process is completed, press Finish in the window shown in Figure 3.4.

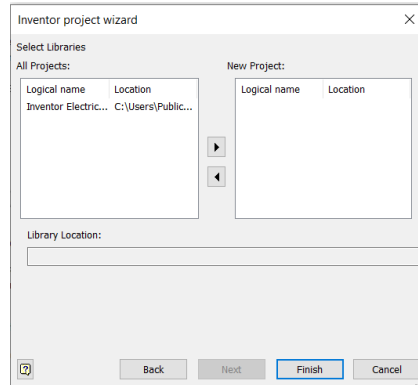

Figure 3.4. Window in Autodesk Inventor where the libraries for the new project are chosen.

It is important to note that you cannot open files from different projects at the same time, only from the active one. If you want to move a file from one project to another, it is best to perform a *Pack and Go*, since it allows all the documents on which that file is supported to move with it, so there will be no problem when opening it. The realization of a *Pack and Go* can be seen in Figure 3.5, where the Source File and the Destination Folder are selected, and by pressing the *Search Now* button all the files on which that assembly is based are searched, found and appear in the box below: Files Found. Once this has been done, *Start* is selected, and the process takes a few seconds.

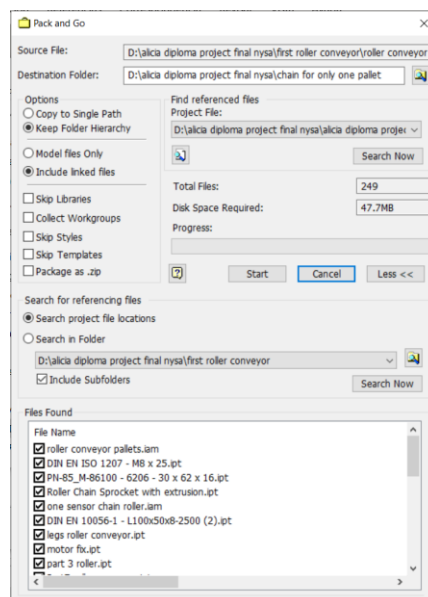

Figure 3.5. Window used to move a file and associated files from one project to another in Autodesk Inventor.

Once you have a project created, it is time to start designing a new element by creating a new file.

## 3.2. FILE CREATION

To start creating a file, press the button at the top right of the home page shown in Figure 3.1, called New. A window like the one shown in Figure 3.6 will appear.

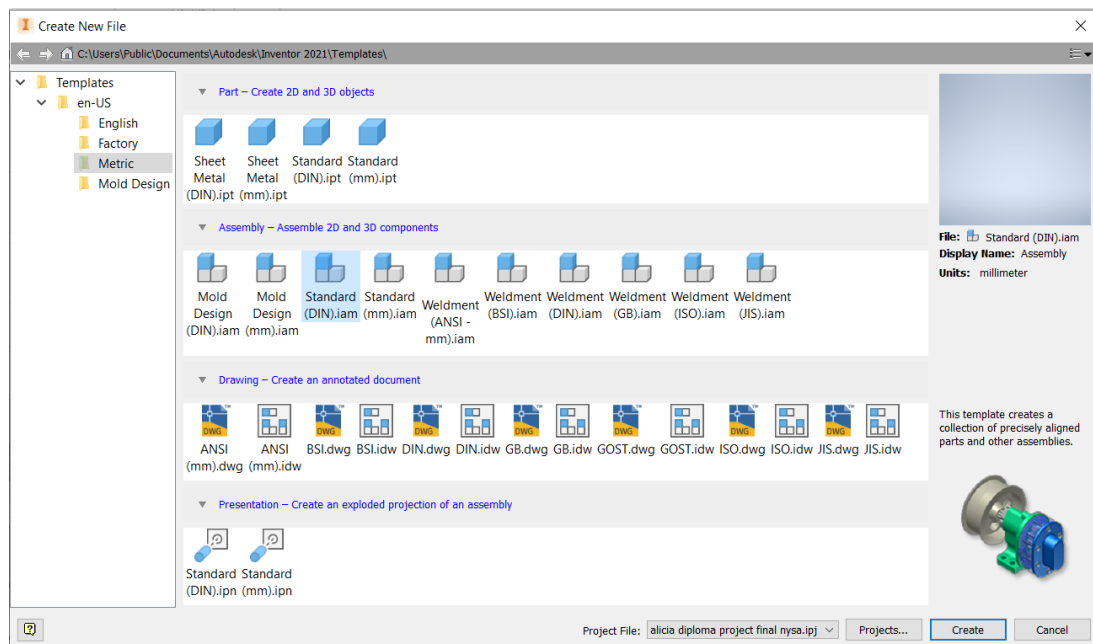

Figure 3.6. Window in Autodesk Inventor for creating a new file.

Figure 3.6 clearly shows the difference between four fundamental blocks or types of files, within each of which there are several according to the standard to be followed. Each of these file types will be discussed in more detail.

### 3.2.1. PIECE FILES (.ipt)

When you open a part file, the part environment is activated. Part commands allow you to manipulate sketches, features and bodies that are combined. To begin, it is necessary to create a sketch: the profile of an operation and any necessary geometry. To create this sketch you select the plane you want to work on and draw different lines or shapes. Once created, it is common to make an extrusion or hole to give different shapes.

A part model is basically a set of operations. It is possible for solid bodies in a part file to share operations. The sketch has constraints that control geometric relationships, such as parallelism. Dimensions control the size. This method as a whole is called parametric modelling: you can adjust relationships or dimension parameters, and automatically see the effect of these modifications. Figure 3.7 shows an example of a part file, chosen as Standard.ipt. This part has two extrusions, two holes where the others have been

created with the mirror or rectangular pattern effect, making use of the orange auxiliary planes that can be seen, and whose visibility is optional. Fillets have also been applied to give a more realistic look to the piece.

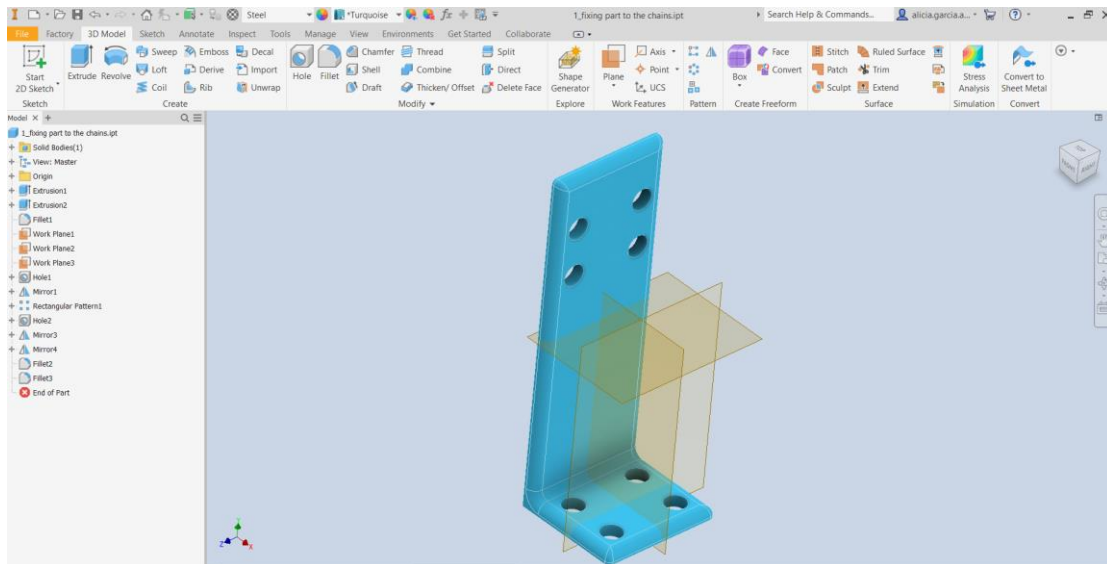

Figure 3.7. Example of a part file in Autodesk Inventor.

All part files have been selected according to the DIN standard.

There is the possibility to choose Sheet Metal.ipt, which allows the user to create different types of operations, as it is shown in Figure 3.8. It includes the option called Sheet Metal, where it is possible flange, cut or bend planes, among other operations, so thin figures as the yellow one in the picture can be created faster.

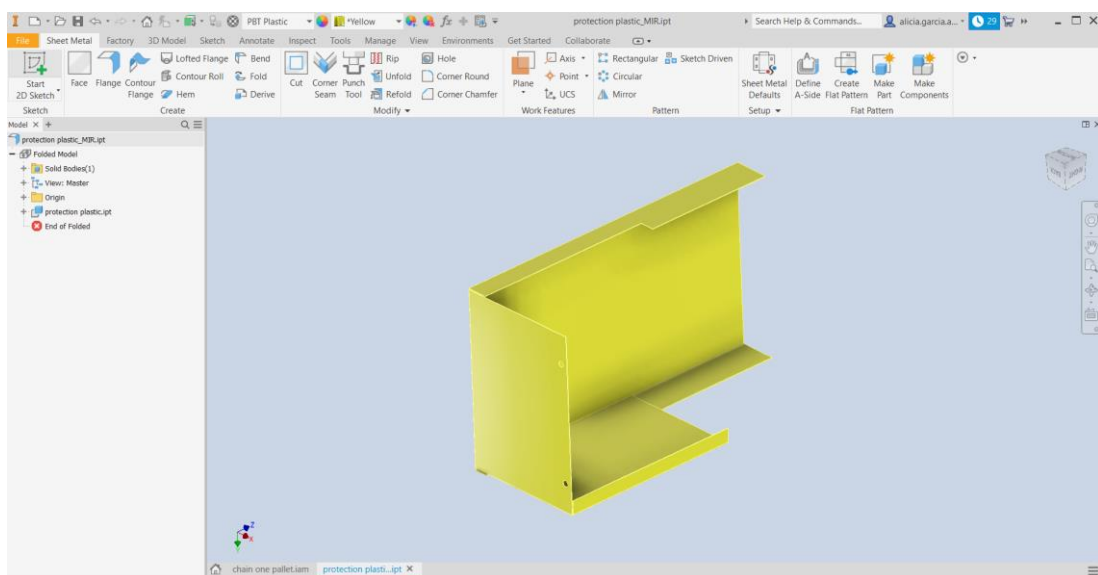

Figure 3.8. Example of a Sheet Metal.ipt in Autodesk Inventor.

### 3.2.2. ASSEMBLY FILES (.iam)

In these files you insert components that will act as a single functional unit in an assembly document. Assembly joints and constraints define the position and behavior of the elements. It is convenient to ground the first component so that everything does not move at once, and then start establishing relationships between the different part files. To ground the first part file that is always placed in an assembly file, you can go to the Toolbar → Tools → Application options → Assembly and check the box that grounds the first part: *Place and ground first component at origin*. This window can be seen in Figure 3.9.

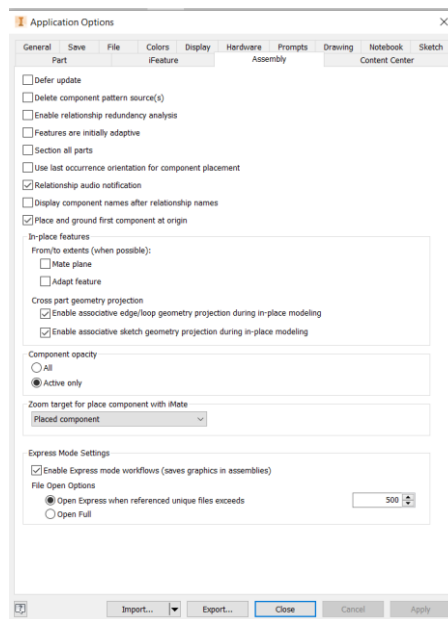

Figure 3.9. Window of application options in Autodesk Inventor.

When an assembly file is created or opened, the assembly environment is accessed. The commands in this environment manipulate subassemblies and assemblies as a whole. You can group parts that work together as a unit. To do this, select the parts to go together, right-click, component, demote, name, and save it.

In addition, in this environment it is possible to insert parts into an assembly and use part commands to create new parts, while the rest of the components are visible.

There are assembly operations that affect more than one component. This is known as machining, an option that allows manufacturing processes that are only visible in the assembly file, but not in the file *.ipt* of that part, such as a hole. This is shown in Figures 3.10 and 3.11. In the first one, only the *.ipt* drawing, part file, is visible, where no hole or other manufacturing process is visible. However, in Figure 3.11 it is exactly the same part seen in an assembly file, where you can see the machining operations that have

been performed, in this case, holes to insert screws or let pass elements that are part of the assembly.

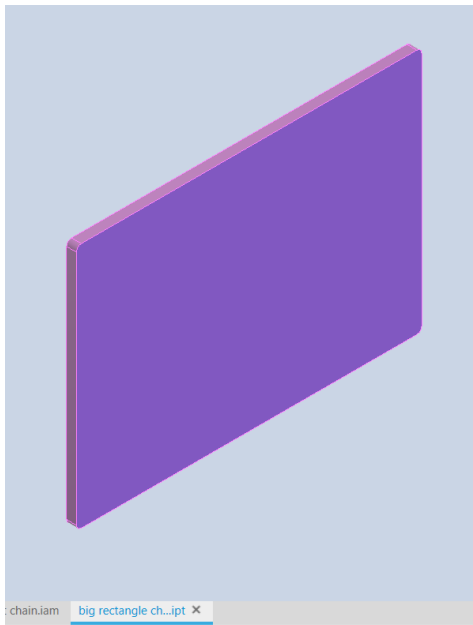

Figure 3.10. Plane in part file .ipt.

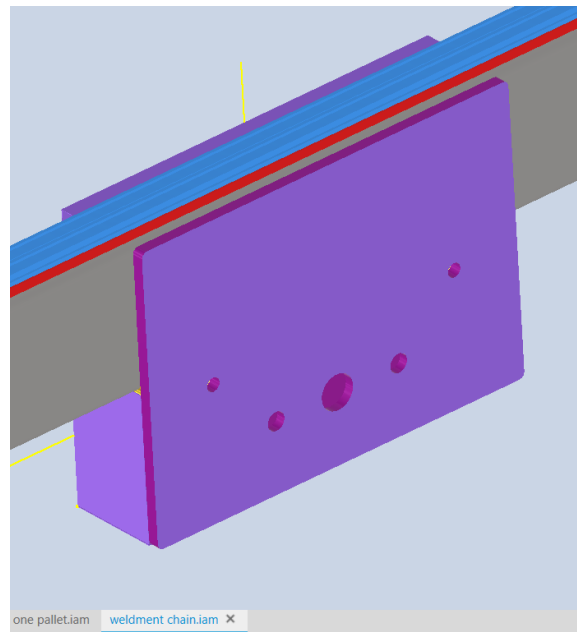

Figure 3.11. Same plane as before with machining operations in assembly file .iam.

It is possible to insert components from the Content Centre. This is a set of libraries with a total of about 750000 elements according to different standards. Once you have chosen one of them, you can select certain parameters such as length or diameter, always according to the indicated standard, and put them in the assembly as if it were another part file. This standardized database can be extended by creating custom content. To use the Autodesk Inventor Content Centre, select Place Component from Content Centre under Assemble, and the window shown in Figure 3.12 will appear. Once this is open, a category from the left column can be chosen and then a particular element that the user wishes to place in their assemble.

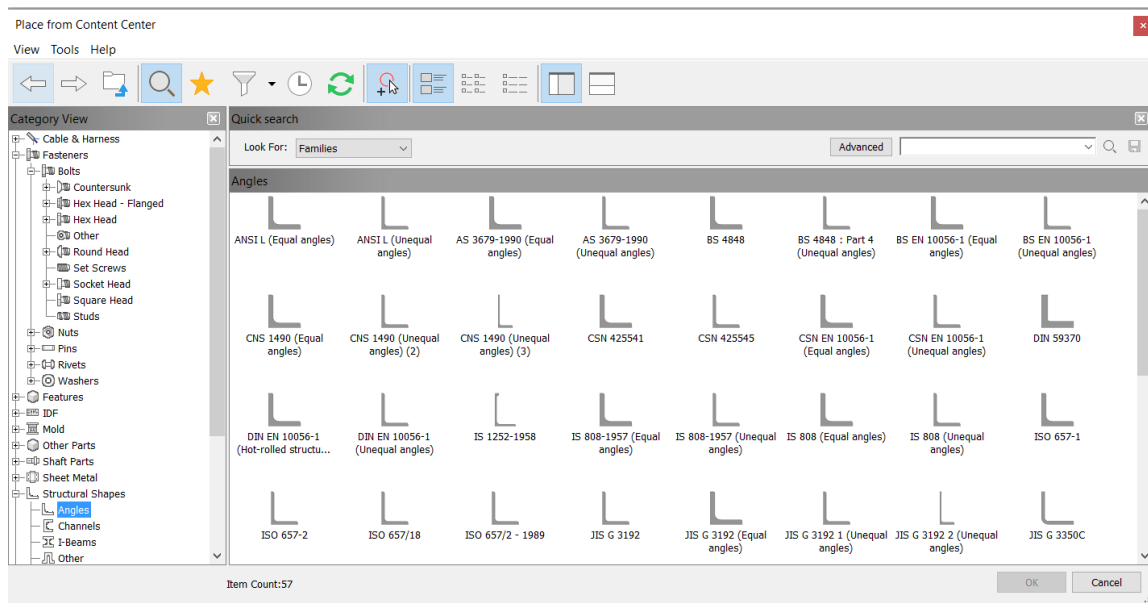

Figure 3.12. Window of the Autodesk Inventor Content Centre.

With assembly files the user can create complex machines composed of multiple parts, which is computationally heavy on the computer, and greatly slows down the operation of the program. For this purpose, in the Toolbar → Assemble → Simplification → Create Simplified Part, a kind of "drawing" is created, a part file from the assembly file, but which is much faster to process and is considered as a joint part. The relationship between the two files can be maintained, so that a change in the .iam will be automatically changed in the .ipt, or conversely, break the relationship and make them completely independent files.

### 3.2.3. PRESENTATION FILES (.ipn)

Presentation files are used to create an exploded view of an assembly for later use in a drawing file, or the creation of an animation that shows the order in which the assembly has been performed step by step. These types of files have not been used in this project.

### 3.2.4. DRAWING FILES (.idw, .dwg)

When the model is finished, it is possible to create a drawing showing the views of the model and to include dimensions and comments in the document. You can also include an automatically generated parts list and a list of elements. Drawings created from models are automatically changed when the component is modified, saving the user the process of redrawing when specific elements are changed. These types of files have been used to create the planes of the different views of the machines created that are attached to the annex 1. In Figure 3.13 there is an example of one of this created files.

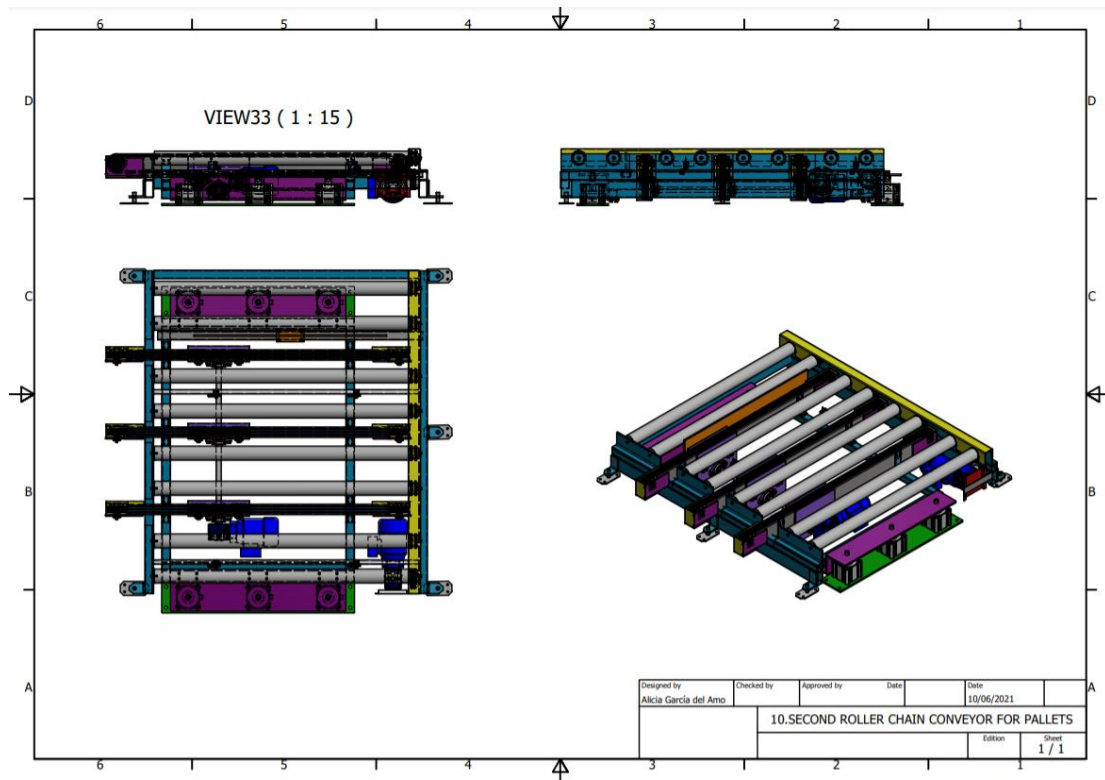

Figure 3.13. Example of a drawing file that is attached to annex 2.



## 4. OBJECTIVES AND ASSUMPTIONS ADOPTED

### 4.1 PROJECT OBJECTIVES

The objective of this project is to conceptually design an automatic system that is receives and returns small items on a sanding processing line. The scope of this project reaches:

- Designing the automatic sanding line in the most practical and economical way so that no human intervention is required at any intermediate point in the process.
- Construction of the machinery as solids in 3 dimensions, and later of the complete automatic line with the program Autodesk Inventor Professional 2021.
- Evaluation and summary of the project that has taken place.

### 4.2. ASSUMPTIONS MADE

The assumptions to be taken into account to carry out this project are the following:

- The incoming wooden parts to be treated have dimensions of 500 x 80 x 20 mm. They consist of oak chipboard. This means that it consists of 5 mm of solid oak wood, a layer of glue and then oak wood fragments of different sizes joined together by a resin or the same glue and then pressed under controlled temperature and pressure. The fact that the material is such a good but expensive wood means that after the sanding process as little wood as possible is lost in the process, so that the thickness of the plates will decrease by 0.3 to 0.4 mm. These sheets will be moved along the line as sets of 14 of these elements separated from each other by 5 mm, so the dimensions of the set of elements that will be transported together are 1070 x 500 x 20 mm.

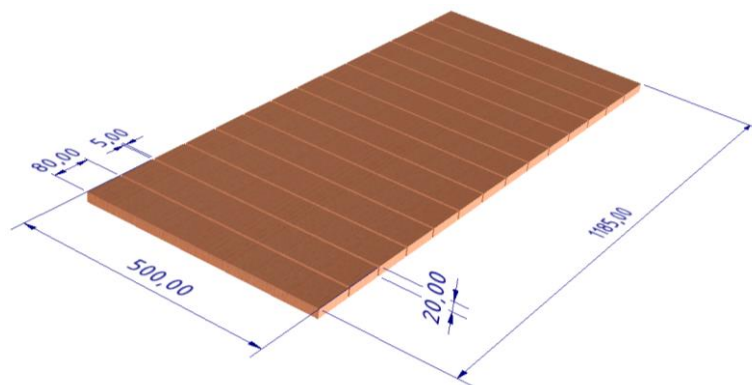
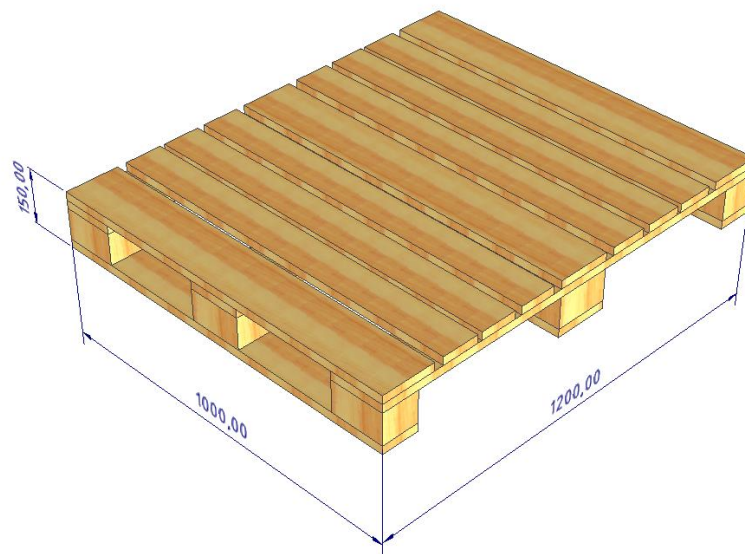

Figure 4.1. Short wooden elements that enter in the line together.

- The pallets that arrive and are automatically transported to the end of the line have dimensions of 1000 mm x 1200 mm, and a thickness of 150 mm, as shown in Figure 4.2. They support a static load of up to 3000 kg and a dynamic load of up to 1000 kg. Their raw material is pine wood. It is a 4-entry pallet, where the windows allow the forklift nails to penetrate through the four sides of the pallet, which makes it possible to load it in any type of vehicle, as it can be placed both frontally and laterally. Their quality follows ISO standards. They are Europallet type pallets. It has the standard pallet dimensions commonly used in Europe, which has to be taken as a reference to favour the logistic operations of cargo handling in storage and transport. Each pallets weights 25 kg approximately.



*Figure 4.2. Wooden pallet with standardized dimensions.*

- The flow of the line must be unidirectional.
- Two pallets of material arrive at a time, with a total of 28 pieces of lumber distributed in two columns, whereas another two pallets with wood elements leave the process line. These bundles of wooden sheets and pallets can be seen in Figure 4.3.

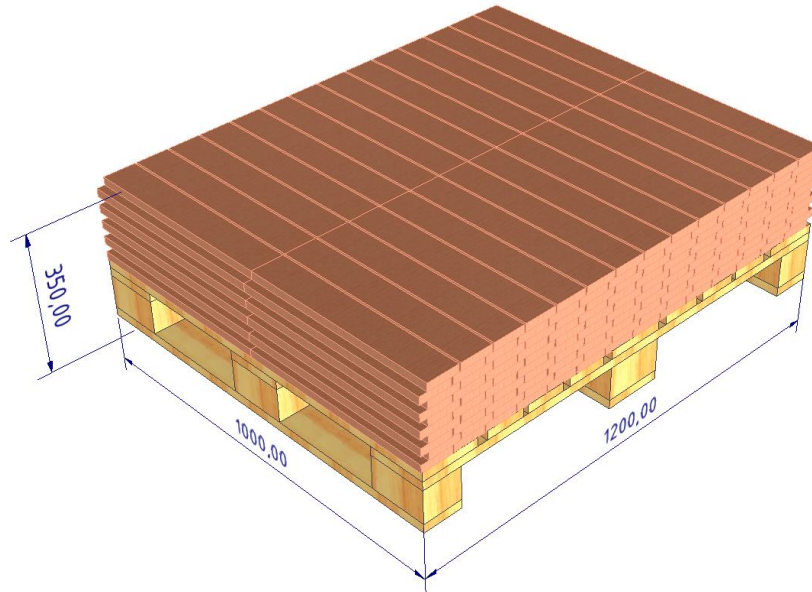

Figure 4.3. Pallet with 20 wooden elements on it.

- The grinding machine is obtained directly from the factory already built, so it is not necessary to go into detail when designing it on the computer. It will be like a box on my line, whose material inlet is 900 mm above the floor.
- The pallets enter and leave the line being transported at a distance of 300 mm above the floor, facilitating their transport once out of the process.
- The pallets must arrive from the beginning to the end of the line automatically, and once there, wait until they are loaded with another 20 sheets already processed.
- The machines to be used must be functional, considering the use of materials and elements suitable for each purpose.
- The process area must be enclosed with protective fences to avoid accidents, except for the material entry and exit areas.

## 5. GENERAL DESCRIPTION OF THE LINE

### 5.1. PROJECT DEVELOPMENT

The line began to be designed by making a conceptual analysis of the tasks to be carried out and in what way, i.e. the sanding of the wooden parts following a fully automated process. Once these guidelines had been established, it was necessary to determine what equipment would be available in the process to ensure proper operation: not conveyor machines, but also robot manipulators were needed. After this initial analysis of the necessary components for the creation of these machines, many companies where the best products considering quality could be obtained and their availability was studied.

I started the design of the line in Autodesk Inventor from the beginning, the first machine to receive the materials, the chain conveyor for the pallets with the material. I then designed the rest of the machinery step by step, following the itinerary that the wooden elements would follow, until I reached the end of the processing of these pieces. When the design was functional, it was time to include the stoppers and sensors needed for a fully automated process.

Once this was done, I started by transporting the pallets from the beginning to the end of the line, taking as a reference the dimensions of the other line and bordering it, creating a flow parallel to it and whose junction only occurred at the infeed and outfeed.

Lately, the safety fences surrounding the process area have been placed to allow working in a safe environment.

Finally, the functionality of the line was studied and checked in order to work the best way possible and obtain reliable results.

### 5.2. GENERAL VIEW OF THE OPERATION OF THE LINE

I will proceed to explain how the process line works, which can be appreciated in Figure 5.1 with the number of each machine, and in Chart 5.2 the name of those numbers will be indicated.

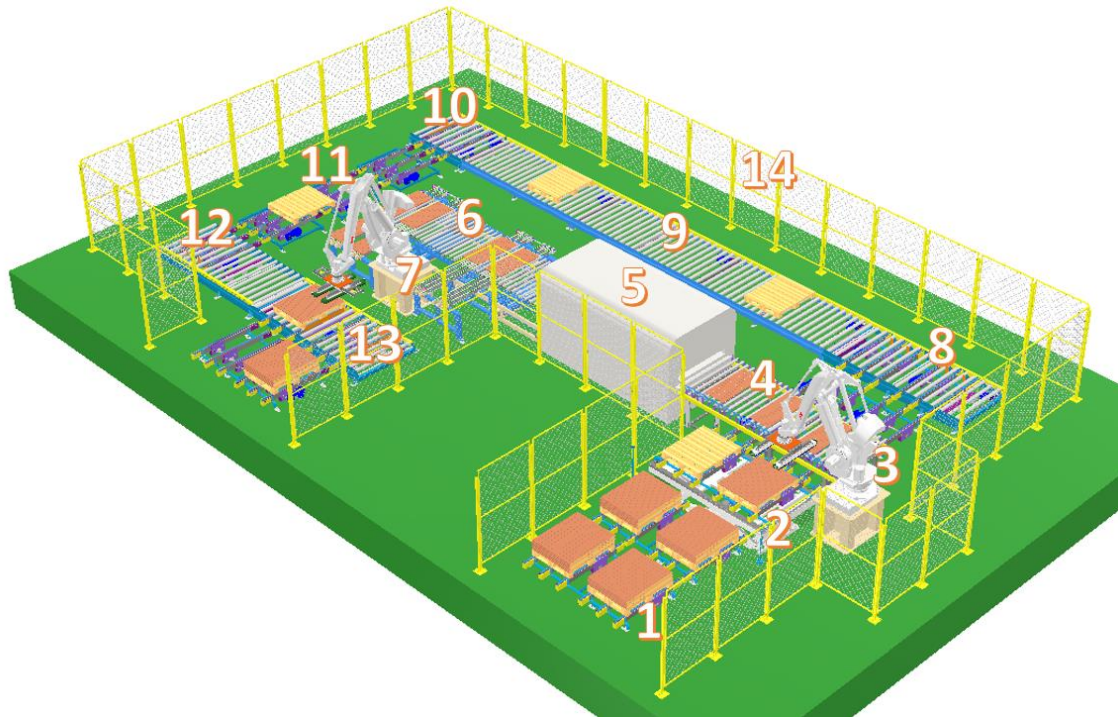

Figure 5.1. Automatic system of sanding wooden pieces. The numbers correspond to Chart 5.1.

Number of the machine	Name of the machine
1	Double chain conveyor
2	Chain conveyor on lifting table
3	Robot with still vacuum gripping systems
4	Roller conveyor for wooden sheets
5	Sanding machine
6	Roller belt conveyor
7	Robot with moving vacuum gripping systems
8	First roller chain conveyor for the pallets
9	Roller conveyor for the pallets
10	Second roller chain conveyor for the pallets
11	Single chain conveyor
12	Third roller chain conveyor for the pallets
13	Fourth roller chain conveyor for the pallets
14	Surrounding protection fences

Chart 5.1. Relation between the numbers written in Figure 5.1 and the name of that machines.



The designed line is U-shaped. A U-shaped layout gives maximum flexibility to the plant, as it is easier to increase or decrease the number of machines in case of a future refurbishment. Furthermore, this gives the possibility to pick up the resulting products from the same side from which they are dropped off, achieving the minimum forklift displacement and reducing the drop-off and pick-up times.

In the following, I will explain in general terms how the machine works, and later on in the rest of the sections I will explain each machine with all its elements in detail.

The pallets with the load have been left by external elements on the chain conveyor. There are two material flows at the beginning of the line. When the lifting table, the rear machine, is free, the two chain conveyors, one behind the other, move the material towards this lifting table. Once the pallet is on top of the chains on the lifting table and these chains have stopped, the table is raised, facilitating the transfer of the oak sheets by vacuum grippers operated by a robot at the side. The robot picks up fourteen sheets of wood with each vacuum gripper, i.e. a whole row of the twelve on the pallet with maximum load from the chain conveyor on the lifting table, and places it on the roller conveyor. Figure 5.2 shows this part of the process line.

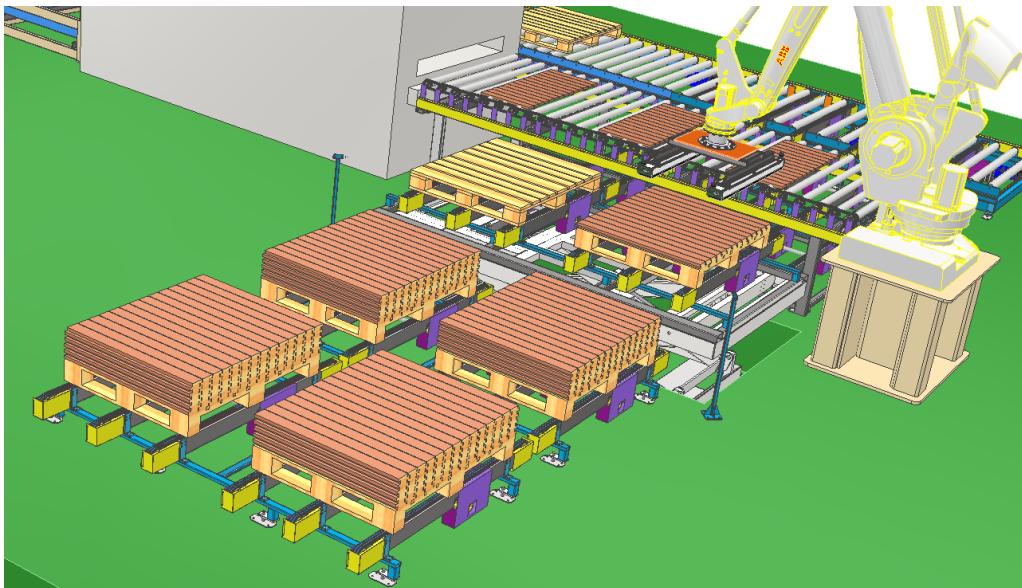
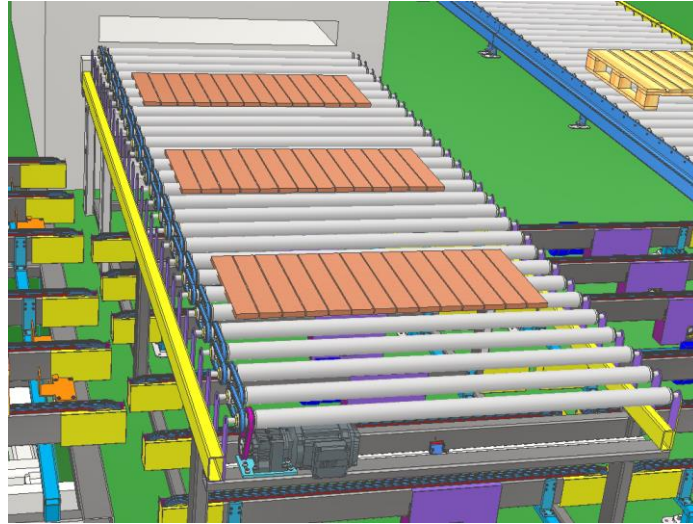

*Figure 5.2. View of the system from the entrance of material*

Then there are two different paths: the one for the wooden sheets to be sanded, and the one for the pallets that go to the end of the line.

The wooden sheets move on the roller conveyor once the robot has released them to the entrance of the calibrating sanding machine. This machine will be responsible for sanding the oak chipboard sheets, which could later be used as flooring, to leave a good

finish. This operation is the main reason for this line, which is a fragment of the processing of this wood. A view of this piece of the route can be seen in Figure 5.3.



*Figure 5.3. Wooden elements entering in the sanding machine by the roller conveyor.*

The lamellas are transported out of the sanding machine by another roller conveyor. Now they have to change direction, so up and down stoppers stop the groups of 14 wooden slats on chain conveyors interspersed with these roller conveyors. When two rows of timber are complete with 14 oak planks each on them, the part of the timber conveyors, which moves up and down, lowers its height and leaves the planks resting on the chain conveyor. The chain conveyor transports them to a place near the next robot. When the twenty-eight blades, fourteen in each flow, are at the end of the chain conveyor, a robot picks them up with vacuum grippers. This line fragment can be seen in Figure 5.4.

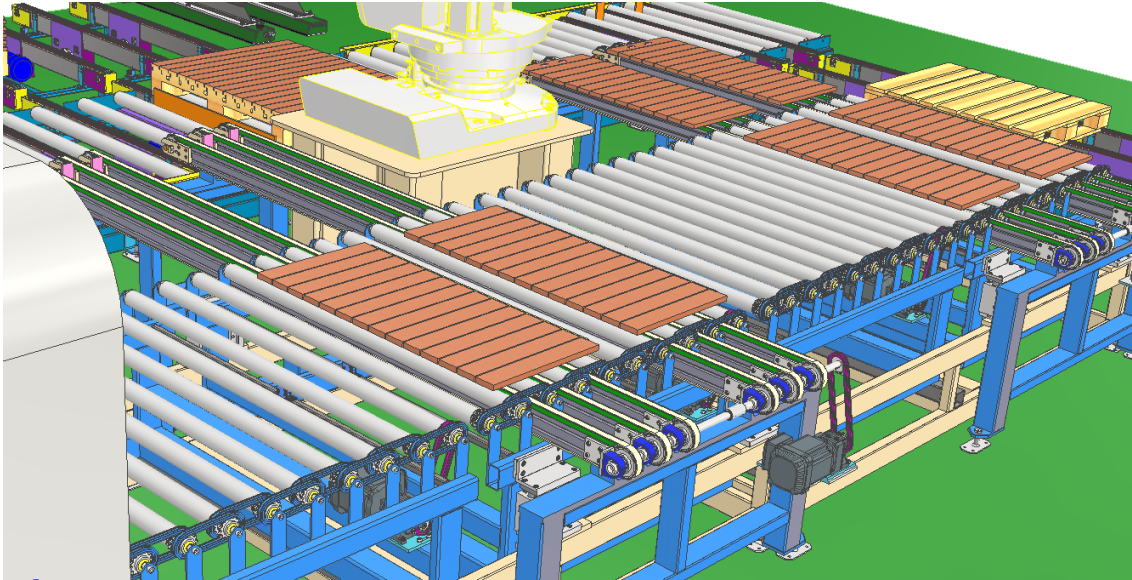

*Figure 5.4. Image from the wooden sheets going out of the sanding machines to the belt roller conveyor.*

This robot picks up fourteen sheets with each vacuum gripper and with a mechanism joins them together so that they fit perfectly on the size of the pallet and places them on these pallets that are on a chain conveyor. He can pick them up from his right or left, as there are two flows of pallets on either side. This last step of handling only the wooden slats is shown in Figure 5.5.

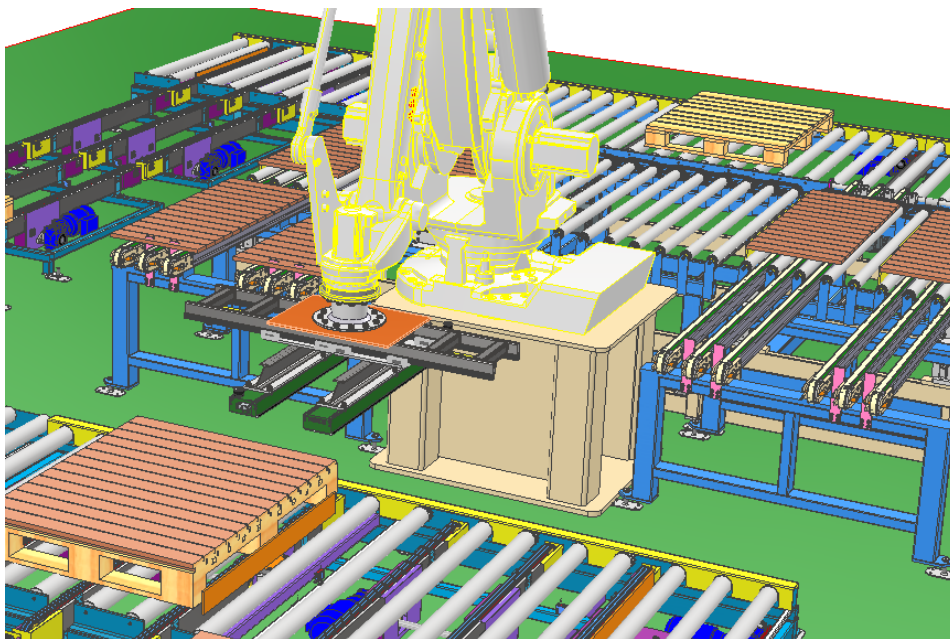

*Figure 5.5. Robot that puts the wood sheets together with the vacuum gripping systems.*



The pallets make a U-shaped path around the line of wooden slats to be processed so that the last robot can automatically place the slats on them. First, the lifting table folds down, lowering its height and allowing the pallets to pass underneath the roller conveyor that transports the wooden slats. Two chain conveyors take it to a roller chain conveyor, where the chains lower their height and the pallet passes over the roller conveyor to change direction to the left. This section of the route can be seen in Figure 5.6.

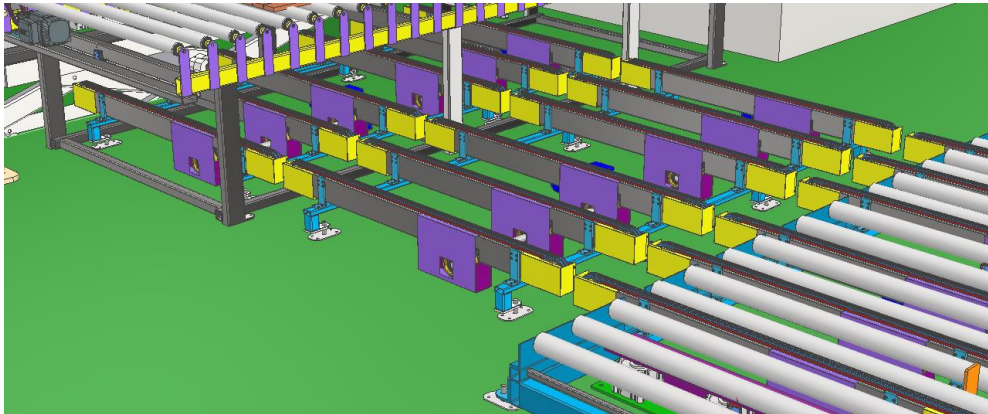

*Figure 5.6. Double chain conveyors that transport the pallets under the roller conveyor.*

The pallets are transported by three roller conveyors until they reach another change of direction, where they are placed on chains because these are raised and take over their movement. For this route, see Figure 5.7.

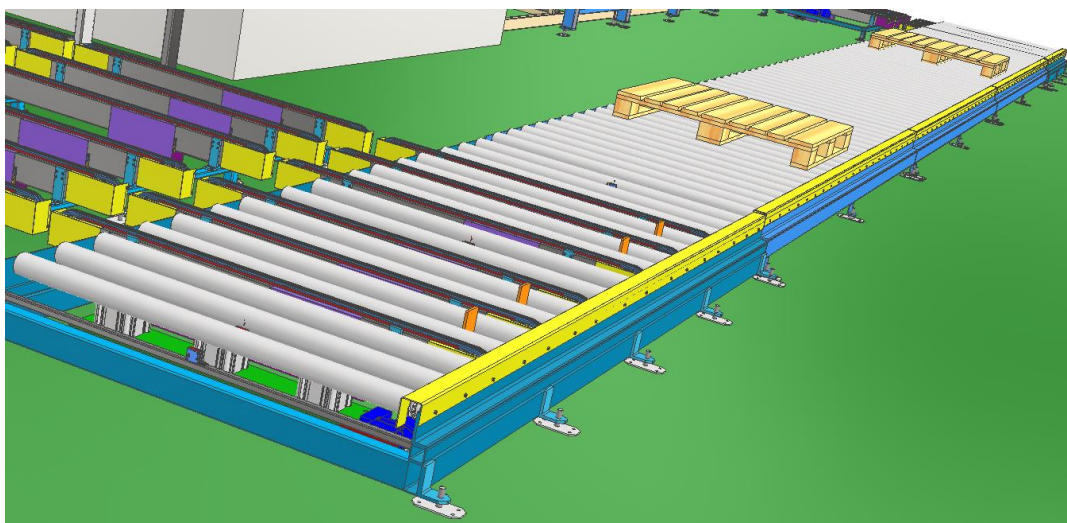

*Figure 5.7. Roller conveyors that transport the pallets.*

The pallets are transported by three fixed chain conveyors until they reach another one that also descends downwards, resting on a roller conveyor and causing the change of direction back to the left. This fragment is shown in Figure 5.8.

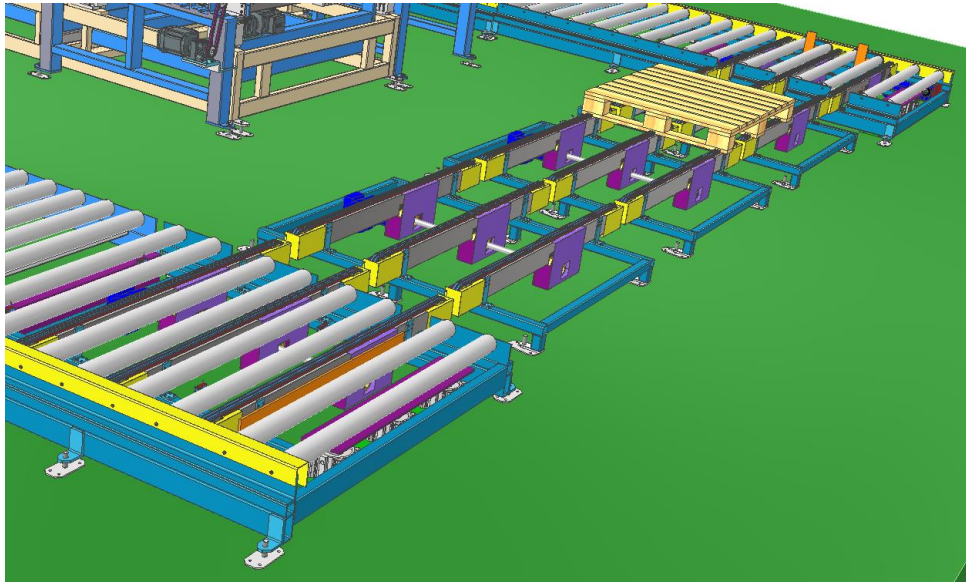

*Figure 5.8. Single chain conveyors that transport the pallets.*

Finally, the pallets arrive at another roller conveyor with interleaved chains. These pallets are stopped in two different places, as the outgoing flow is also double, avoiding agglomerations of outgoing material in case there is a delay in picking them up. Once the chains are lifted, placing the pallets on them, the robot leaves the wooden slats on them once it has put them together. When the pallet is completely filled with twelve rows of wooden slats, which the robot calculates thanks to the way it is programmed, that chain begins its movement towards the end of the line, placing itself on the last chain conveyor and waiting to be picked up. This end of the process is shown in Figure 5.9.

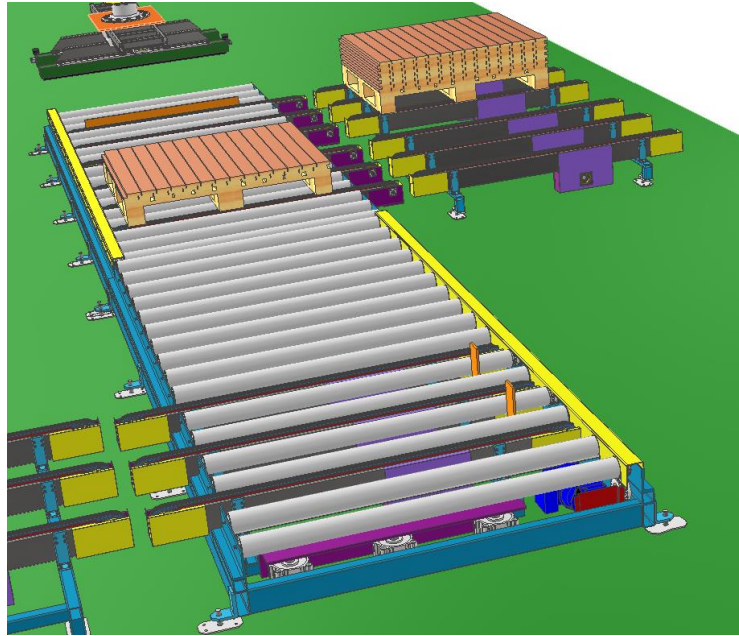

Figure 5.9. Image of the pallets in the last part of the system.

## 6. COMPONENT SUPPLIERS

In order to be able to build the machines, it is necessary to obtain the material from reliable companies that offer good quality at a reasonable price. For this purpose, different companies have been consulted, whose material can be easily shipped to Poland and whose popularity makes them reputable and satisfied customers.

The parts needed have been selected taking into account the needs to be satisfied, as well as the requirements of the material to be handled, since the weight and dimensions of the material will influence the decision. No less important is the guarantee of an efficient and safe product, with a long life cycle that allows its use over time.

The offer of various manufacturers has been studied by consulting their websites, where they explain who they are and show the catalogues of all the products they offer.

It should be noted that these companies make available to the user CAD drawings of their products that can be downloaded free of charge in .STP format by selecting the parameters that the customer wishes. These drawings can be opened with the Autodesk Inventor program and included in the desired assembly.

The manufacturers chosen to supply elements to the process in question are MÄDLER GMBH, SMC GmbH, HIWIN GmbH, ABB and SICK. The logos of these companies are shown in Figure 6.1.



Figure 6.1. Logotypes of the enterprises producing machine components and equipment related to automatization used in the project.

## MÄDLER GMBH

MÄDLER GMBH is a German company founded in 1882, one of the leading producers and suppliers of power transmission elements and standardized parts. It has two manufacturing plants in Germany and three sales branches. They do business all over the world. It stands out for its wide range of products with good availability, as you can find drive elements, shock absorbers, pneumatic components, gears, adhesion elements and guide rails.

A large number of products are manufactured in Germany, and those that are not, follow German quality standards. This means top quality, precision and reliability. MÄDLER's quality management is certified according to DIN 9001:2015.

On their website you can find all products with their instruction manual, certificates, safety data sheet, price and an indication of their availability. It is possible to download CAD drawings, which have been used in this project. They offer about 28000 products with the necessary information, and about 96% of these can be purchased directly from stock.

## SMC GmbH

SMC Corporation was established in 1959 in Tokyo, Japan, under the trade name of Sintered Metal Corporation. It used to manufacture synthesized metal filters and filtration elements.

Today, they are experts in industrial automation, making use of the most advanced motion control technology. Their product range covers a total of 12,000 products, with 700,000 possible variations, and their solutions cover air preparation, instrumentation, valves and actuators, covering virtually every step in the automation process.

Its staff is responsible for offering tailor-made solutions and ensuring the supply of components and products that best suit the customer's requirements. Its global market share is 31%, it has sales offices in 83 countries, has 36 manufacturing plants around the world with ISO9001 and ISO14001 accreditation.

## HIWIN GmbH

HIWIN Technologies Corporation was founded in 1989 in Taiwan. It is currently the second largest manufacturer of linear motion control and system technology in the world. Its product line includes precision pocket spindles, linear guides, linear motors, servo motors, precision bearings for spindle tips and industrial robots.

Its features include high speed and precision, as well as multi-functionality and environmental protection. It covers fields as diverse as medical equipment, industrial automation, material handling, automotive, food, energy, or textile machinery, among others.

It is a company that strives to produce Industry 4.0 solutions, being a global supplier with a catalogue and investment in R&D more outstanding. It is also possible to download its products in CAD format for use in computer programs such as this project.

## ABB

ABB or ABBN: SIX Swiss Ex has a history of more than 130 years. They seek excellence by innovating, taking advantage of the electricity that was new at the time. It is a company concerned with transforming society and industry with productive and sustainable technology. It stands out for its energy efficiency, reliability and productivity. They advocate fast response, good product life cycle, availability and productivity.



Its leading businesses span four core sectors:

- Electrification. Supplies components such as distribution automation, EV infrastructure, metering, cabling and control, from substation to outlet.
- Process Automation. This is number two in the global market, offering digital and electrification solutions, control technologies, software, advanced services and metering.
- Motion. ABB is the world's largest supplier of drives and motors: electric motors, generators, drives, services, mechanical transmission services and complete solutions. They serve many automation applications in the transportation and industrial process industries.
- Robotics & Discrete Automation. Its focus on innovation-focused artificial intelligence, integrated automation solutions, robotics and expertise place it in a major global presence.

It is located in more than 100 countries with a workforce exceeding 110,000 employees.

## SICK

SICK is a company founded in 1946 in Munich, Germany by Erwin Sick, engineer and optician. It offers intelligent sensor solutions for factory automation technology in logistics and process automation. Today, the company is a technology and market leader, providing safe and efficient products for process control, as well as for the protection of people and the environment. It is committed to constant innovation, investing in R&D and establishing relationships with universities and schools, ecological sustainability and customer satisfaction. It offers sensor solutions for mobile platforms, robotics and machine vision.

It has international standardized certificates for quality management, environmental management and industrial safety. It has a worldwide presence, with more than 50 subsidiaries and participations, with 10,000 employees last year.

## AB SKF

The SKF Group, or Aktiebolaget Svenska Kullagerfabriken, meaning ball bearing factory in Swedish, was founded in 1907 in Gothenburg, Sweden. The inventor of the double row spherical ball bearing, Sven Wingquist, was one of the founding members and the first managing director. On June 6, they filed their first patent application and the first factory.

Thus was born a now multinational company, present in about 130 countries, whose expertise lies in developing, designing and manufacturing bearings, seals, lubrication systems, power transmission and mechatronic products. They also offer machine condition assessment, reconditioning and reliability engineering services. Their flagship product is bearings, ranking among the world's largest bearing manufacturers.

SKF aims to be at the heart of industrial reality, the biggest challenge in today's age, with reliable performance for the real world. They are committed to innovation, the constant improvement of their rotating equipment. They are present in virtually all sectors, from the aerospace industry, construction, oil industry, through the food industry to the transport or paper industry, among others.

## TECHNIK CNC

This Polish company deals with the sale of machine parts and tools used in CNC. It is a new company whose aim is to develop the company itself. They are flexible and adapt their offer to the customer's needs.

They offer high quality tools and machine parts and industrial devices from leading manufacturers worldwide. They guarantee reliable and professional execution of demands as well as urgent consultation services.

Among their products, you can find a wide variety of products, such as rail guides, chain tensioners, sprockets, pulleys, linear bearings, ball screws, rail guides and gear wheels are some examples.

## NORD

The company NORD was founded in 1965 by G. Schlicht and G.A. Küchenmeister. Since then, it has been manufacturing all components required for drive technology, both mechanical and electronic. This includes gearboxes, electric motors and drive technology. They offer individual drive solutions because they manufacture all their products themselves.

Today their group has become one of the world's leading full-range suppliers of this technology, thanks to their forward-looking character and the offer of reliable, safe, long-life and flexible products. They have subsidiaries in 36 countries and agencies in 52 countries.

The principles of their factories are to respect the environment and thus achieve energy savings and higher performance. They offer the highest quality standards at all their

locations, complying with DIN ISO 9001, DIN 3990, NIEMANN, AGMA and ATEX. They are even the originators of an international standard for monobloc crankcases.

### FAMAD SP. Z o.o.

FAMAD Sp. Z o. o. Industrial machines and Devices Factory, based in Paczków, Poland, has been producing high quality machines and devices with modern design solutions that are highly competitive in order to better meet customer demands for over 60 years.

Its products are divided into the groups listed below:

- Machines and devices for the woodworking industry, such as doors and windows, making the best use of high quality wood material and not wasting it.
- Machines and devices for the furniture industry, with operations such as veneering and varnishing.
- Hydraulic cylinders, whose use can be adapted to multiple sectors such as automotive, agriculture or civil engineering.
- Process transport and automation of loading and unloading operations on these lines.

The company has a quality management system and complies with the specifications of the standard PN-EN ISO 9001:2001 for the design, production and sale of devices and machines. All its products have the CE declaration of conformity and comply with the European Machinery Directive and harmonised standards.

### COSTA LEVIGATRICI S.p.A

Costa Levigatrici company manufacturing wide belt sanding machines was established in 1982 in Schio, after another company with the same name that manufactured since 1900 hydraulic turbines, flower mills and stows. It is a world-leading manufacturer of automatic sanding equipment for the treatment of wood, metal and hard surfaces. High quality, reliability and innovation are the most remarkable characteristics of its machines.

Nowadays the company manufactures deburring, finishing and dross removal machines for wet and dry process of sheet metal and wooden parts after different processes. These processes can be punching, laser cutting or treatments that require cleaning, grinding, polishing and finishing.



They count with an official distributor of globally known high class sheet wood and metal fabrication machinery brands.

## PIAB AB AND KENOS

Piab group is a company created in 1951 by Sven Tell, who developed his unique drawing compass due to his fascination with number  $\pi$ . The name of the company has its origin in this number and AB, the Swedish word for Incorporated (Inc.). Since then, new inventions have been made. It develops progressive solutions for gripping, lifting and moving. They believe in an automated world where no resources are wasted. They always strive to improve, as their more than 65 patents and countless innovations show. Moreover, that innovations are increasing every day.

They are specialized in automated process components and solutions, so its products are mostly related with automatization:

- Vacuum pumps and ejectors.
- Suction cups and soft grippers.
- Robot End Of Arm Tooling (EOAT) components.
- Robot and Cobot gripping solutions.
- System and solution accessories.
- Vacuum conveyors for powder and bulk.

All its components have multiple applications related to different industries: Packaging, Pharmaceutical, Plastics and Automotive, Logistics and Warehouse and Chemical.

They count with 650 employees, 100 countries presence, 900 partners globally and 25 sales offices throughout the world.

In June 2016 Piab acquired Italian-Based Kenos. KENOS is a company established in 2021 in Montegrotto Terme, Italy. It had 9 employees and 1000 square/meter factory. It is a leading company in the market of large area vacuum grippers in various applications, e.g. packaging, wood, food, etc. Its main purpose is design and manufacture vacuum grippers: generators like venturi ejectors and blower pumps, and technologies as check valves and flow reductions.

## SEW WURODRIVE GmbH & CO KG

Sew Eurodrive is a German company that manufactures drive technology. It was founded in 1931 by the Blicke family. It combines the concepts of Industry 4.0 with the principles of Lean management.

The company produces gear units, motors, gearmotors, electronically controlled drives, control technology and mechanical variable-speed drives. Also a lot of services are available, like engineering or selection from the start to the maintenance of the product.

They produce compact drives in the motor power and also powerful gear units with very high input torques.

Their products stand for diversity, reliability and the power of innovation. As one of the leading manufacturers of drive technology in the world, having 16,000 employees all over the world, they offer customize parameters for their products. Moreover, automation is another field where they are operating now, offering system solutions for factories and machine automatization.

## 7. CHAIN CONVEYOR FOR THE PALLETS

The machine shown in figure 7.1 illustrates the chain conveyor that conveys two pallets with or without material. As explained before, the movement of the pallets that feed and go out the process must be 300 mm high. The conveyor total length is 1760 mm and the width of the machine 2600 mm.

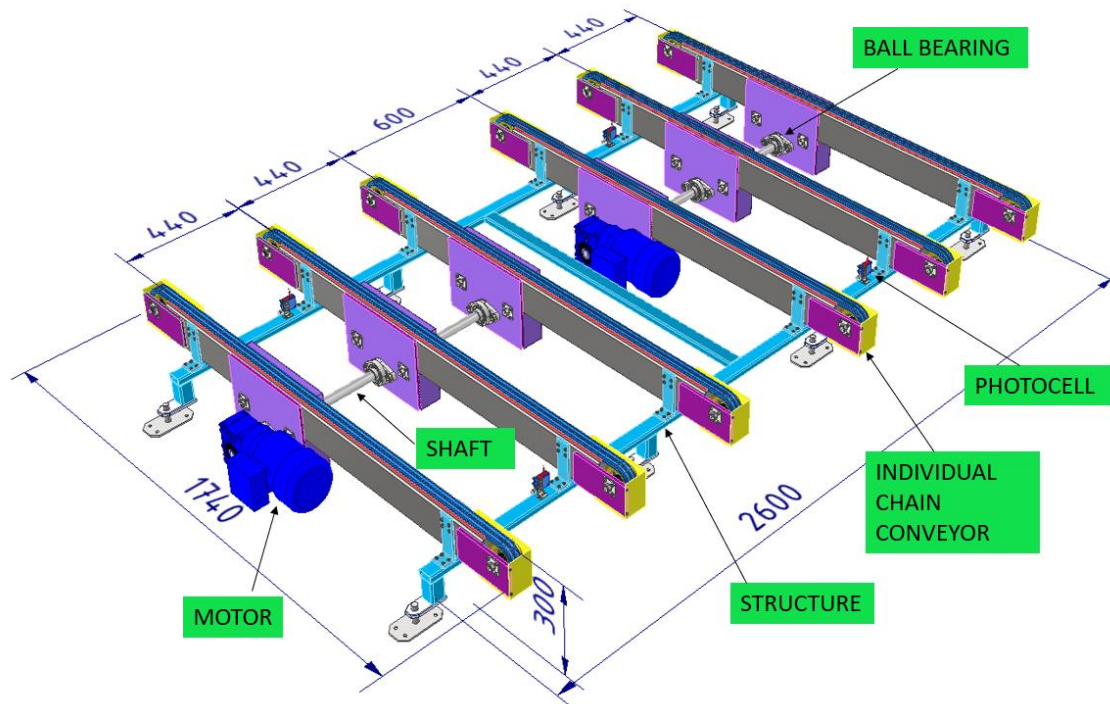

Figure 7.1. Chain conveyor for transporting the pallets.

A total of six chains are placed on this machine. The three chains on each side are used to transport a different pallet, either with or without material. Each group of three chains is 440 mm apart, allowing each 1000 mm wide pallet to be supported by three chains at the same time, on the sides and in the middle, ensuring reliable transport. They are controlled by independent motors to guarantee the independence of one pallet flow from the other. The separation between the two lines is 600 mm, guaranteeing that there will be no interference between the two flows. I will explain each part in detail.

## 7.1. INDIVIDUAL CHAIN CONVEYOR

The chains are the main element of this machine. Figure 7.2 shows a single chain on both sides.

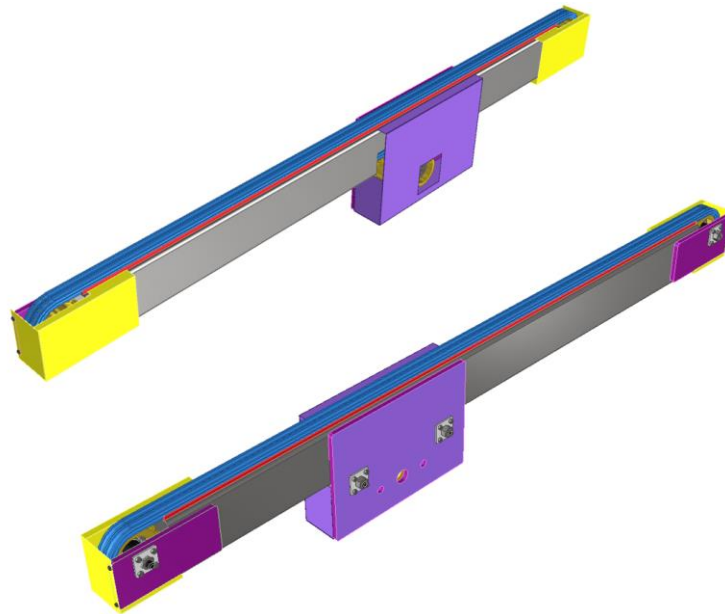

Figure 7.2. Chains used in the chain conveyor.

The total length of the structure is 1730 mm. It consists of a structural element on which the whole structure is supported, a hollow rectangular tube, grey in colour, which follows the DIN EN 10210-2 standard, with dimensions 120X60X4 mm, and a length of 1500 mm. This component can be easily obtained from the Autodesk Inventor Content Centre. The element obtained is shown in Figure 7.3 with its dimensions. The hole it has will later be used to place the sprockets necessary for the transmission of power, and consequently the movement of the chain.

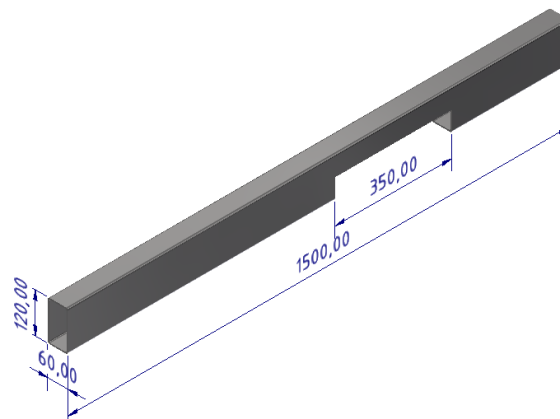

Figure 7.3. Rectangular tube with dimensions, used in chain structure and taken from Content Centre.

## 7.1.1 CREATION OF THE CHAIN AND SPROCKETS

The chain drives have been created using one of the functions of the Design Accelerator module. With this option, a customised chain can be easily created. To start, the Roller Chains option is selected and a window like the one shown in figure 7.4 on the left appears. Once there, you select the type of sprocket you need from a list, shown in the same figure on the right.

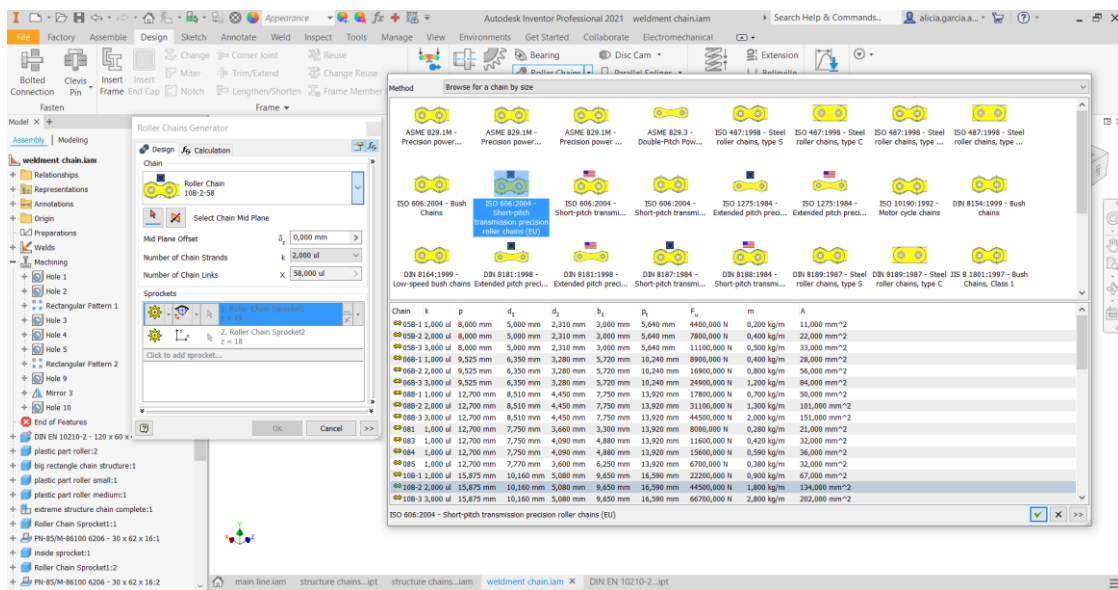

Figure 7.4. Screenshot on Autodesk Inventor on how to select a sprocket and create a chain.

The ones chosen for this chain are from the ISO 606:2004 standard - Short-pitch precision transmission roller chains (EU), model 10B-2-58, whose characteristics are shown in the same window highlighted in blue. Once accepted, the number of teeth is chosen, parameter  $z$ , which has been chosen as 19. To know the sprocket in more detail, just select the option highlighted in blue in the Roller Chains Generator window in figure 7.4, and the information shown in Figure 7.5 will appear.

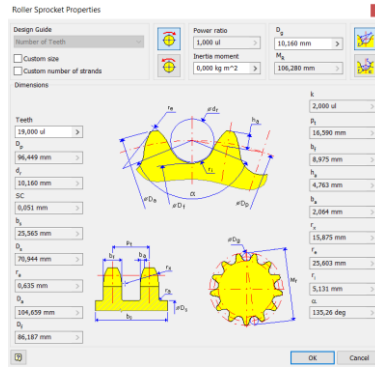

Figure 7.5. Characteristics of a sprocket 10B-2-58 with 19 teeth.

Once this process has been completed, a structure with two sprockets and a chain at a given distance will be available, as shown in figure 7.6.

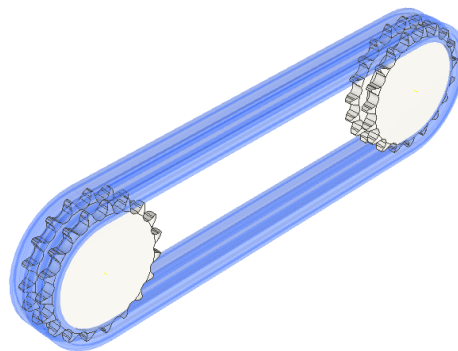

Figure 7.6. Chain created in Autodesk Inventor with 19 teeth.

However, this is not exactly what I want. If you search on the Internet on the TECHNIK CNC page, you can find the chain wheel with the desired characteristics that can be found on the market. You can see that the number of teeth is the same, i.e. the sprocket does not change, but it has a protruding part, called a bulge, and a hole in the middle with certain standardised dimensions, information shown in figure 7.7.

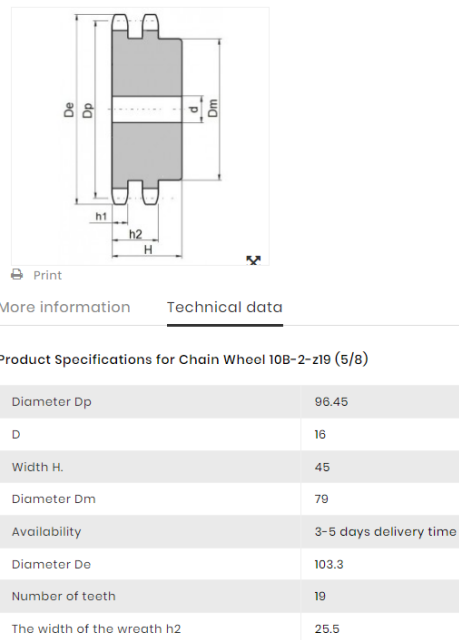

Figure 7.7. Technical data of the chain wheel 10B-2-z19 from website TECHNIK CNC.

In order to modify the cogwheel I have obtained with the Design Accelerator tool, just select one of the cogwheels and save it independently as a .ipt part file. Now I can change the colour and edit it by making sketches and extrusions, to get to that same figure. The result is shown in Figure 7.8.

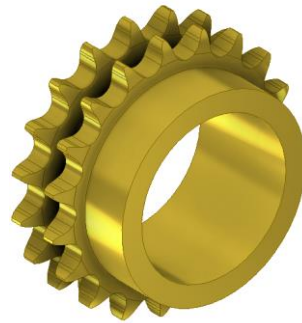

Figure 7.8. Sprocket edited as the ones available in the market and used in the chain conveyors.

Now all that remains is the last step, which is to place the wheels at the desired distance in a new assembly and attach the chain that passes through them. The positioning of the wheels is simple, the first one is selected and copied several times in the desired places. The distance between the two wheels at the ends is 1600 mm. Now, for the chain, it is necessary to use the Design Accelerator again, but this time, instead of using the wheels provided by Autodesk Inventor, I select the ones I have placed myself. It is necessary to specify in which direction the chains are going to turn, and finally accept to arrive at the chain shown in Figure 7.9.

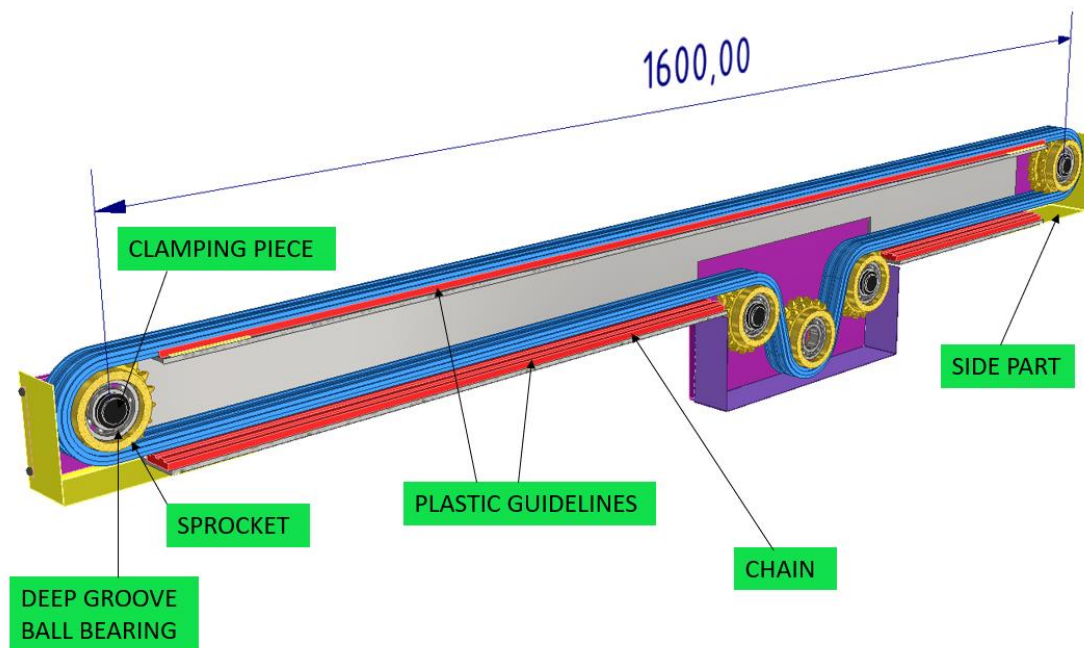

Figure 7.9. Cut view of the final chain with sprockets inside the structure.

It should be mentioned that a Deep Groove ball bearing is inserted inside each gear wheel. A ball bearing is composed of rolling balls, separated by two bearing rings, whose function is to reduce the contact surface and friction in the moving planes. The presence of the balls reduces the coefficient of friction. Deep groove ball bearings are the most widely used bearings because of their versatility. They are optimised for low noise and low vibration, allowing high rotational speeds. They require less maintenance than other types of bearings. The specific type chosen can be found in the Autodesk Inventor Content Centre → Shaft Parts → Bearings → Ball Bearings → Deep Groove Ball Bearings. It follows the Polish standard PN-85/M-86100, 6206, with dimensions 30x62x16 mm. It is shown in figure 7.10.



Figure 7.10. Deep groove ball bearing placed inside the sprocket.

Inside this ball bearing, all the wheels, except the middle one through which the shaft leading to the motor passes, have a part like the one shown in figure 7.11. This black part is used to hold the gear wheels, as the narrower part is inserted in the purple planes.



The ball bearing is placed in the middle part, between two slightly wider cylinders, to prevent transverse displacement.

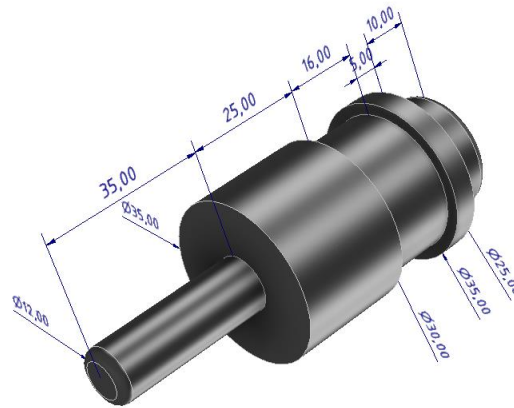

Figure 7.11. Clamping piece introduced inside the deep groove ball bearings.

The purple end flats have dimensions 210x100x10mm, and a 5mm fillet at the corners. They are welded to the grey rectangular structure. It has a 13 mm diameter hole made by machining in the assembly, not in the part file, for a correct insertion of the black part. This part is held by a standardised nut DIN EN 28673 M14 X 1.5 mm. Between this nut and the purple plane there is a grey rectangular piece of dimensions 45x45x3mm, which separates both parts, and is fixed to the purple plane thanks to the presence of four standardised screws, one in each corner, DIN EN ISO 1207 M6, nominal length 15 mm.

To complete the ends of this chain, there is a yellow plastic safety piece whose main function is to protect the area where the toothed area is located, so that, on the one hand, it prevents particles from entering, rubbing against it and causing its deterioration, and on the other hand, to protect human beings, in the event that a worker is near the chain, so that no accident occurs. This piece has been created with the Sheet Metal file, creating a main face and then flange it to create the desired shape. Finally, it has two holes for the screws that hold it to the purple plane. The screws are DIN EN ISO 7045 H, M4 x 10, where 10 is the nominal length in millimetres.

This assembly at the end of the chain is shown in detail in Figure 7.12.

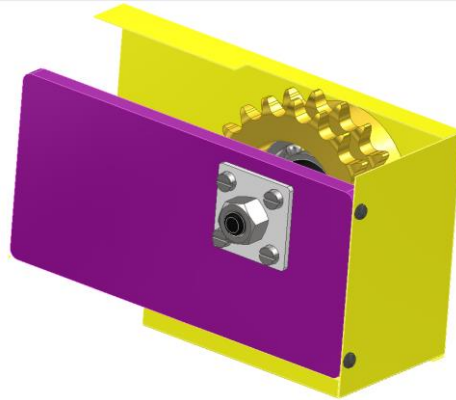
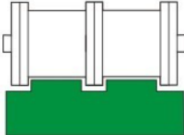
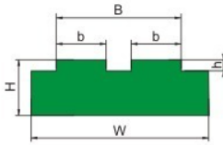

Figure 7.12. Part in the side of the chain transporter.

On the other hand, the chain has a standardised profile and a guide to this chain is required. Its information can be seen in figure 7.13, which is taken from the DAGAR company website.

Home /Chain guides /Type T2 /

## Type T2

Product code	DIN 8187 chain	Chain dimensions	ln (mm)	H (mm)	b (mm)	h (mm)	B (mm)
	<input type="text" value=""/>						
D00129	06B-2	3/8 "x 7/32"	25	10	5.4	1.5	15.6
D00130	08B-2	1/2 "x 5/16"	35	10	7.4	2.2	21.2
D00131	08B-2	1/2 "x 5/16"	35	15	7.4	2.2	21.2
D00132	08B-2	1/2 "x 5/16"	35	twenty	7.4	2.2	21.2
D00133	08B-2	1/2 "x 5/16"	35	thirty	7.4	2.2	21.2
D00134	10B-2	5/8 "x 3/8"	40	10	9.3	2.6	25.7

Figure 7.13. Profile of the guideline type T2 of the chain.

It is necessary to create a plastic part that is attached to the grey beam with this T2 profile, DIN 8187 chain 10B-2, so that it guides the chain during its movement, and in case of contact, there is no wear of the chain. This is the red part that can be seen in Figure 7.14.

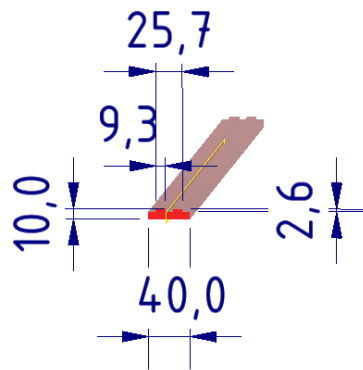

Figure 7.14. Dimensions of the guideline of the chains.

The rectangular plane that holds three sprockets has dimensions of 240x350x10mm. It has a hole in the middle for the central sprocket through which the motor shaft passes. This sprocket is the one that receives the power, and consequently, the movement of the motor, transmitting it to the chain that causes the movement in the rest of the sprockets. It also has two holes to hold an oval shaped ball bearing which I will talk about later. There are another two holes to hold the sprockets as in the side planes, with their holes and with the same type of bolts and nuts. Figure 7.15 shows the front and rear view of this area of the structure.

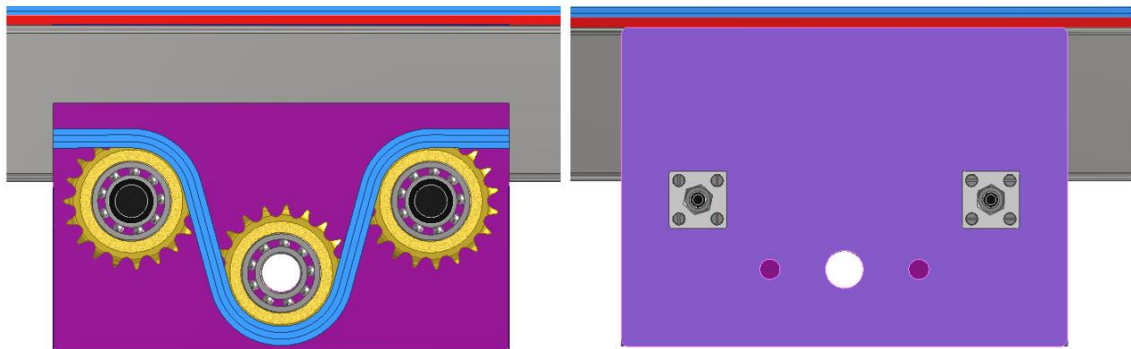
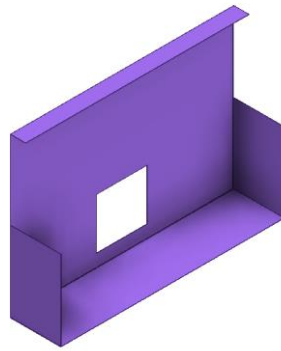

Figure 7.15. Half view of frontal side and full view back side of the central part of the chains where the power is transmitted.

These sprockets are also covered by a purple protection created as a Sheet Metal, with a hole to allow the shaft to pass through to the motor and partly observe the movement of the sprocket. This component can be seen in Figure 7.16.



*Figure 7.16. Protection part of the three sprockets situated in the biggest plane in the chain.*

This part concludes the general explanation of a specific chain. I will now go on to explain the components that produce the movement in these chains.

## 7.2. MOTORS, SHAFT AND BALL BEARING WITH OVAL FLANGE

### 7.2.1. PRELIMINARY CALCULATIONS FOR THE MOTORS

The motor is responsible for delivering the necessary power to produce the movement of the wooden shafts. The motor chosen to carry out this task must meet a series of characteristics that ensure the proper functioning of the chain.

### TRANSPORT OF PALLETS WITH MAXIMUM LOAD

The first two chain conveyors have to transport the pallets with  $14 \times 12 = 168$  wood sheets.

It is known that the wood is made of oak conglomerate. A block of 1 cubic metre,  $m^3$ , of this material ( $1000 \times 1000 \times 1000 \text{ mm} = 10^9 \text{ mm}^3$ ) weighs 800 kg.

If I have each piece of wood with dimensions  $500 \times 80 \times 20 \text{ mm} = 8000000 \text{ mm}^3$ , or  $8 \cdot 10^{-3} \text{ m}^3$ .

On each pallet loaded to the maximum, there are 28 wood elements in each row (14 on each column), and there are 12 rows, making a total of 336 wood elements.

In total, all the pieces of wood on a full pallet occupy  $336 \text{ elements} \cdot 8 \cdot 10^{-3} \text{ m}^3 = 0,2688 \text{ m}^3$ .

Therefore, a complete set of wooden slats weighs  $0.2688 \text{ m}^3 * 800 \text{ kg/m}^3 = 215.08 \text{ kg}$ .

This calculation corroborates that the assumption of placing this number of wooden slats on the pallet that supports a maximum of 1000 kg in a dynamic situation, as specified in section 4.2. *Assumptions made*, is adequate. Putting more rows of slats, increasing the height, would compromise stability, so it is considered an ideal choice.

To this must be added the weight of the pallet, which is about 25 kg, which is also discussed in section 4.2. In total I have  $215.08 + 25 = 234.08 \text{ kg}$ .

Therefore, the force of gravity exerted by the whole assembly will be  $234.08 \text{ kg} * 9.81 \text{ m/s}^2 = 2296.33 \text{ kg} * \text{m/s}^2$ , or in other words, 2296.33 N.

On the other hand, using the formula for calculating the revolutions per minute on machine tools with the metric system in millimetres, I have:

$$RPM = \frac{1000 \times V_c}{\pi \times d}$$

Where:

- $V_c$  the linear transport speed of the chain in [m/min].
- $D$  is the diameter of the sprocket in [mm].

We want the linear transport speed to be 10 m/min, since a higher speed would compromise the stability of the pallet and the load on it as it reaches a height of 350 mm. Bearing in mind that the diameter  $D_p = 96.5 \text{ mm}$ , as shown in figure 7.5, we have the following operation:

$$RPM_{motor\ 1} = \frac{1000 \text{ mm/m} \times 10 \text{ m/min}}{\pi \times 96,5 \text{ mm}} = 32,99 [1/min]$$

In conclusion, a rotational speed of 33 [1/min] is required, with slightly higher rotational speeds being acceptable.

### TRANSPORT OF PALLETS WITHOUT LOAD

The pallets without load, as calculated in this chapter previously, is 25 kg. Consequently, the force of gravity exerted by the pallet will be  $25 \text{ kg} * 9.81 \text{ m/s}^2 = 245.25 \text{ kg} * \text{m/s}^2$ , or in other words, 245.25 N.

Moreover, the pallets without load can go a little faster, and less power is required as the load is lighter. The speed can be between 15 m/min and 20 m/min.

$$RPM_{motor\ 2, 15 \text{ m/min}} = \frac{1000 \text{ mm/m} \times 15 \text{ m/min}}{\pi \times 96,5 \text{ mm}} = 49.48 [1/min]$$

$$RPM_{motor\ 2, 20\ m/min} = \frac{1000\ mm/m \times 20\ m/min}{\pi \times 96,5\ mm} = 65.97\ [1/min]$$

To summarize, the rotational speed required is between 49.48 [1/min] and 65.97 [1/min] for the pallets with load and without it, respectively.

## 7.2.2 CHOICE OF MOTORS

Taking into account the data calculated in the previous section, a motor can be chosen that meets the required characteristics.

The choice on the basis of this data has been made in the NORD catalogue. I have chosen the product with the name Worm Gears UNIVERSAL SI.

These motors are modular, have universal coupling facilities and are available in IEC versions. Quality assurance is based on ISO 9000 standards, also following global standards such as CE. The NORD modular worm products are designed with high strength, aluminium alloy housing. This makes it corrosion resistant, aids heat dissipation, lowers the temperature, extends the life of the product and is lightweight and durable. The FLEXBLOC™ universal worm gear housing offers modularity and adaptability since all worm modules and input and output accessory kits are stocked at the factory for easy assembly by NORD or the customer. This product has Oversized Output Shaft Bearings, which extends bearing life, allows it to support large cantilever and thrust loads, increases strength by having larger internal shaft diameters and has larger hollow bore capacities. The motors are internationally accepted to meet North American NEMA MG 1 and international IEC standards. The motor materials are designed for cool running and long life. They are able to operate at maximum performance in dynamic applications due to low motor inertia and high starting torque. They offer high efficiency meeting worldwide energy requirements. They have thermal overload protection, forced cooling fans, heaters and encoders, and can withstand voltage peaks.

### MOTOR FOR THE CHAIN CONVEYORS TRANSPORTING MAXIMUM LOAD

The motor type is SK 1SI63 - IEC80 - 80LP/4 B14 C120. The main features are:

- Input speed 1415 1/min.
- Ratio of 40
- Output speed 35 1/min, slightly higher than required.

- Output torque 131 Nm.
- Overhung load of 5.9 kN, sufficient for the load it supports.
- Axial load 7.8 kN.
- Power of 0.75 kW, which is valid for transporting the pallet and the material.

Figure 7.17 shows an image of the motor on the left, and its component parts on the right.

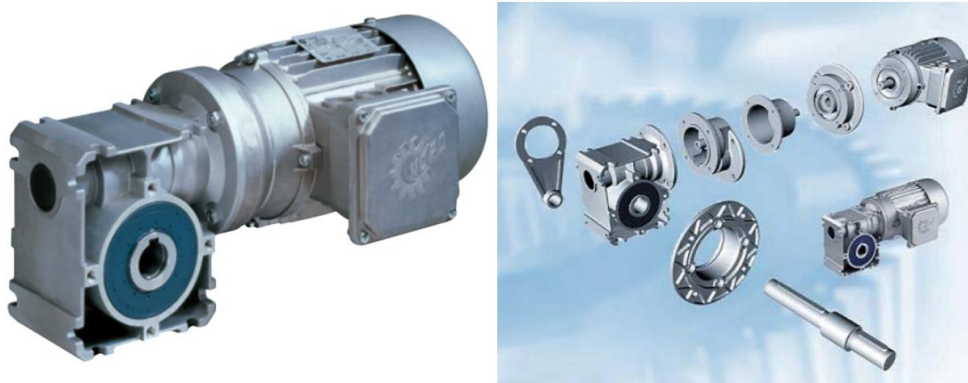

*Figure 7.17. On the left, a picture of the motor Worm Gears UNIVERSAL SI. On the right, the pieces that form that motor.*

It is possible to download this engine in CAD drawing format and place it in the project I am working on. This drawing can be seen in Figure 7.18.

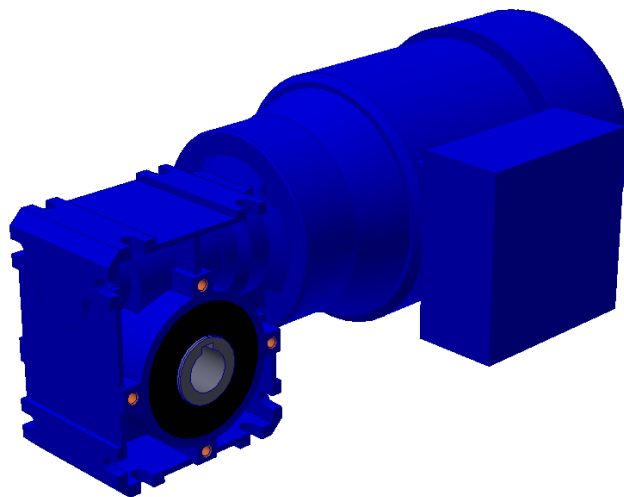

*Figure 7.18. CAD drawing of the motor Worm Gears UNIVERSAL SI, SK 1SI63 - IEC80 - 80LP/4 B14 C120.*

Annex 1 contains a drawing of the engine in question, with all its views including its dimensions. Annex 2 contains the documentation with the detailed characteristics of the same engine.

### MOTOR OF THE CHAIN CONVEYOR TRANSPORTING ONLY PALLETS

For the chain conveyors that transport only pallets the model and type of motor is the same, SK 1SI63 - IEC80 - 80LP/4 B14 C120, as well as the appearance, but some of the characteristics must change:

- Input speed 1420 1/min.
- Ratio of 25.
- Output speed 57 1/min, between the numbers calculated for the speed between 15 and 20 1/min. With this specific rotational speed, the lineal speed will be:

$$V_C = \frac{\pi \times 96,5 \text{ mm} \times 57 \text{ 1/min}}{1000 \text{ mm/m}} = 17.28 \text{ [m/min]}$$

- Output torque 70.5 Nm.
- Overhung load of 5.1 kN, sufficient for the load it supports.
- Axial load 7.8 kN.
- Power of 0.55 kW, which is valid for transporting just the pallet.

This are the most remarkable differences compared to the other motor, but there are also more changes in parameters in the motor. This information is contained in the datasheet in the annex 2.



### 7.2.3. MOTOR SHAFT

The shaft which has to pass through three different gears has been designed as one piece file. The diameter of the part that goes inside the ball bearings is 30 mm. The part that goes inside the motor is somewhat different. Its diameter is 25 mm, and it also has a small part that protrudes by 4 mm. The resulting shape is shown in figure 7.19.

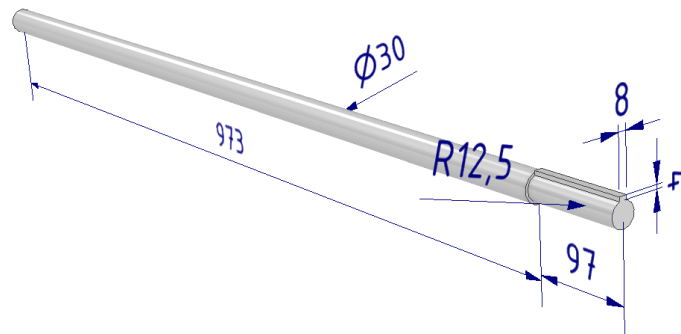

Figure 7.19. Axis that connects the motor and three chain sprockets.

### 7.2.4. BALL BEARING WITH OVAL FLANGE

This bearing is placed on the outside of each chain, facing the motor, ensuring a clean entry at exactly the right place to each of the sprockets.

The SKF FYTJ 30 TF oval flange ball bearing unit has been chosen. SKF flange-mounted ball bearing units consist of an insert bearing mounted in a housing. An insert bearing is a deep groove ball bearing with a spherical outer surface and an extended inner ring. The latter includes a mechanism whose function is to fix the unit on the shaft.

The housing can also be bolted to the wall or to the machine frame. It has a spherical bore corresponding to that of the ring, but the ring is concave. The product follows the Japanese industrial standard JIS. The ball bearing units can withstand moderate initial misalignment. However, they do not allow axial displacement. In addition, they are very versatile and cost-effective, which makes them a feature in a wide range of industrial applications.

The product is shipped ready to install. The bearings are lubricated and sealed, and locking on the shaft is fast. Concentric locking options are available for high speeds and low vibration.

Its main characteristics can be seen in the documentation in Chart 7.1 below.

Compliance with standard	JIS
Purpose specific	For material handling applications
Housing material	Cast iron
Sealing solution	Standard seals with additional fingers

#### CALCULATION DATA

Basic dynamic load rating	C	19.5 kN
Basic static load rating	C <sub>0</sub>	11.2 kN
Fatigue load limit	P <sub>u</sub>	0.475 kN
Limiting speed with shaft tolerance h6		6 300 r/min

Chart 7.1. General information about the FYTJ 30 TF oval flanged ball bearing.

For more technical information, the annex 2 contains all the technical specification of the FYTJ 30 TF Oval flanged ball bearing unit, including all its dimensions and mounting information.

A comparative image between the real element on the left and the element obtained by downloading the CAD drawing on the right is shown below in Figure 7.20.

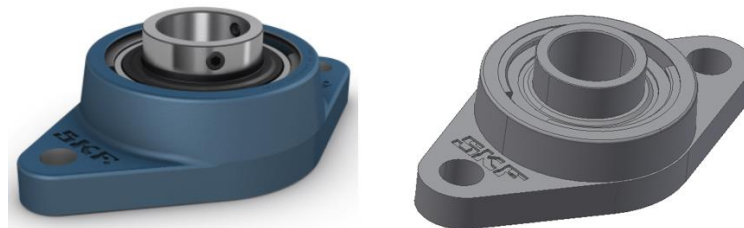

Figure 7.20. Comparison between a real FYTJ 30 TF Oval flanged ball bearing units and the CAD drawing.

These bearings have been fixed to the larger rectangular plane of the chain with DIN 6912 M14 X 20 bolts (diameter 14 mm as recommended by their technical specifications in annex 2), and the final result of their position can be seen in Figure 7.21.

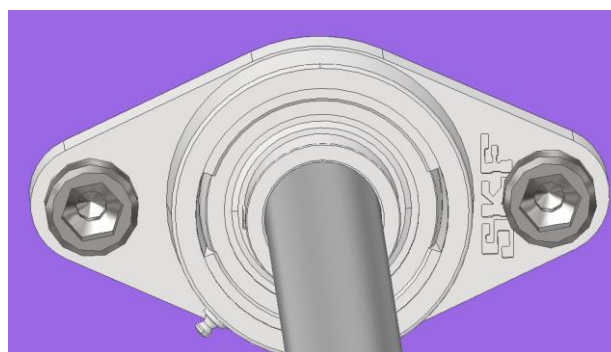

Figure 7.21. FYTJ 30 TF Oval flanged ball bearing in the assembly.

### 7.3. CHAIN CONVEYOR STRUCTURE

Each chain is supported by four L-shaped pieces, two at each end, with four DIN 920 M8 X 8 bolts on each of the two flat surfaces. The dimensions can be found in Figure 7.22.

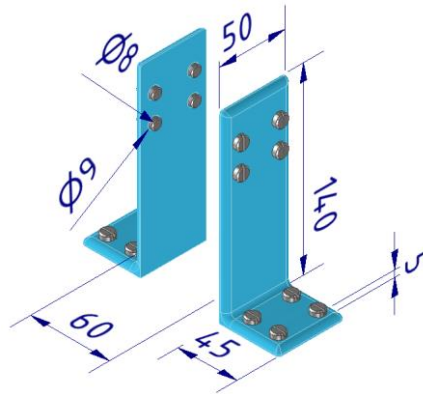

Figure 7.22. Structure that holds and fixes the chains to the main structure.

The structures to which these parts are attached are standardised rectangular tubes DIN EN 10210-2 - 50 x 25 x 3 mm, length 1600 mm. Four other vertical rectangular frames DIN EN 10210-2 - 50 x 50 x 4 and 70 mm long are placed under each of the two long tubes, at a distance of 250 mm from each other. These legs are attached to a rectangular-shaped structure with two fillets at the front and a hole. Through this hole passes a screw that is welded to a geometrically shaped plane, which has four holes that can be anchored to the floor. With this part we ensure that, despite the tolerance that can vary some dimensions, I can adjust the height of the machine to 300 mm, complying with the standards and facilitating its transport, since the pallets that reach this chain do so from a forklift. Figure 7.23 shows one of these three-piece assemblies with its dimensions.

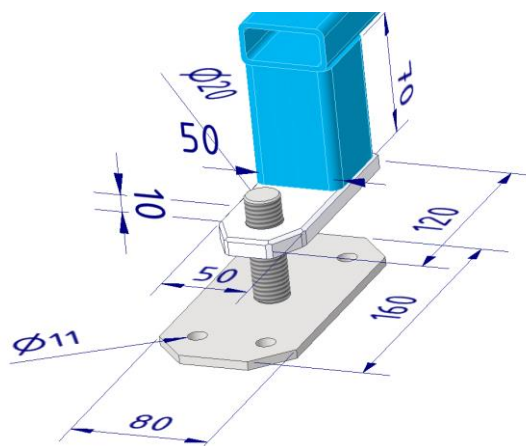

Figure 7.23. Group of components that join the structure with the floor.

## 7.4. CHAIN CONVEYOR SENSORS

### 7.4.1. ELECTION OF THE SENSORS

As mentioned at the beginning, the line must be fully automated. Therefore, it must be constantly known where each element is in the process, whether it be the wooden slats or the pallets. To achieve this, sensors have been placed along the entire length of the line for this purpose.

The most suitable sensors for detecting the presence or absence of an object in a certain position are photocells.

A photocell is an electronic device that acts as a photoelectric sensor depending on the intensity of light in the environment: it detects light levels and reacts to them according to its programming, model, and functionality.

The chosen device belongs to the W12-3 photocell group from SICK. The characteristics of this sensor are as follows:

- Reliable detection due to the innovative chip technology, which is highly insensitive to optical interference, making it suitable for industrial environments.
- The localisation technology enables clear, small and precise light spots, making alignment of the sensor quick and easy.
- It can be used universally thanks to the variety of robust metal housings.
- The switching process is precise. This factor together with its high detection quality guarantees universal object detection.
- Quick and easy integration using function blocks.
- Simple mounting and installation process as well as parameter setting.
- Simple access to the information contained in the PLC thanks to IO-Link.
- It has a CE compliance declaration.

The specific article type is type WL12-3V2431, with article number 1041537. A picture of this sensor can be seen in Figure 7.24.



Figure 7.24. Small photoelectric sensor WL12-3V2431 from the company SICK.

The main technical data of this sensor are the following explained in Chart 7.5.

<b>Sensor/ detection principle</b>	Photoelectric retro-reflective sensor, autocollimation
<b>Dimensions (W x H x D)</b>	15.6 mm x 48.5 mm x 42 mm
<b>Housing design (light emission)</b>	Rectangular
<b>Sensing range max.</b>	0 m ... 7 m <sup>1)</sup>
<b>Sensing range</b>	0 m ... 5 m <sup>1)</sup>
<b>Focus</b>	Approx. 1.5°
<b>Type of light</b>	Visible red light
<b>Light source</b>	LED <sup>2)</sup>
<b>Light spot size (distance)</b>	Ø 100 mm (3 m)
<b>Angle of dispersion</b>	Approx. 1.5°
<b>Wave length</b>	640 nm
<b>Adjustment</b>	Potentiometer, 5 turns

Chart 7.5. Detailed technical data provided about the photoelectric sensor WL12-3V2431 from the company SICK.

The mean time between failures of the asset, MTBF, i.e. the mean time when the equipment is working properly between failures, is 1.543 years, which provides a long time operation without any failure.

The dimensions of all the elements present in the sensor can be seen in Figure 7.25.

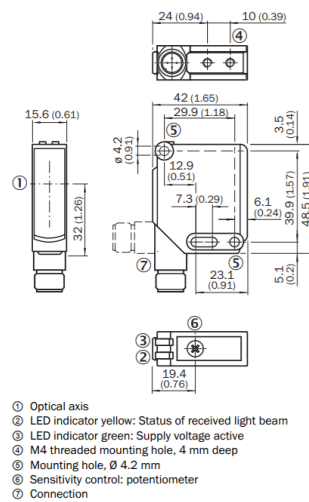

Figure 7.25. Dimensional drawing of the sensor WL12-3V2431 from the company SICK. Dimensions in mm (inch).

In order to know more detailed information about the sensor, check in the annex 2 the datasheet of the sensor, looking at the reflector PL80A, that contains information about the wiring scheme, the characteristic curve, electronics and mechanics of this photoelectric sensor, among other data.

#### 7.4.2. FIXING PART OF THE SENSOR

The sensor must be fixed to a surface. For this purpose, a mounting element is required to fit the sensor. In the SICK catalogue there is an L-shaped part with several screw holes. It is a mounting system type BEF-WG-W12 and part number 2013942, which is normally available from stock. The part itself can be seen in picture 7.26.



Figure 7.26. Picture of the mounting system type BEF-WG-W12.

Its detailed technical data can be seen in the Chart 7.7.

<b>Accessory group</b>	Mounting brackets and plates
<b>Accessory family</b>	Mounting brackets
<b>Suitable for</b>	W11-2, W12-3, W16
<b>Material</b>	Stainless steel
<b>Items supplied</b>	Mounting hardware included
<b>Description</b>	Mounting bracket, large

Chart 7.7. Technical specifications of the mounting system type BEF-WG-W12.

Finally, the Figure 7.27 shows an scheme of the piece indicating its dimensions.

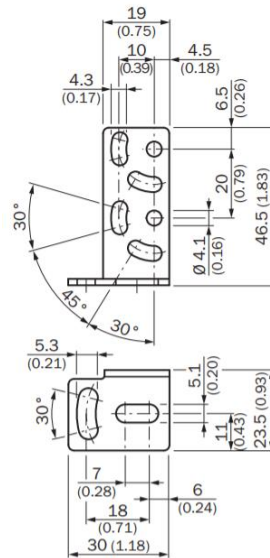

Figure 7.27. Dimensional drawing of the mounting system type BEF-WG-W12. Dimensions in mm (inch).

The datasheet of the mounting system is attached in the annex 2 of this project.



### 7.4.3. SENSOR ASSEMBLY AND MOUNTING SYSTEM

The assembly of the sensor with the mounting system has been carried out with two DIN EN ISO 1207 M4 X 25 screws, inserting them through the holes in the sensor for this purpose. Two DIN EN ISO 7040 M4 nuts have been fitted on the other side to prevent them from slipping out. The same screws have been used to fix them to the desired structure on the machine.

The assembly of the two components seen from two opposite sides can be seen in Figure 7.28.

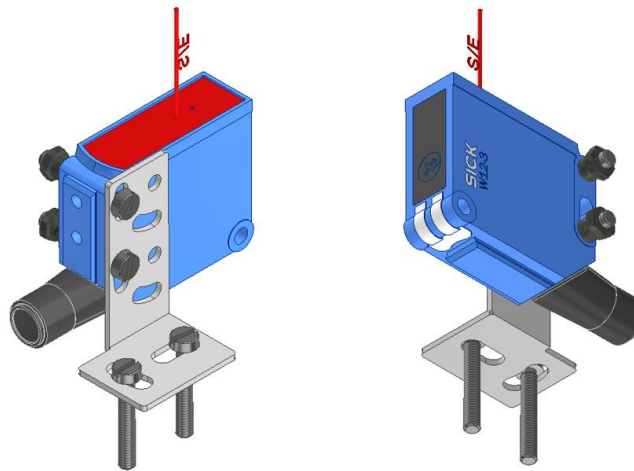

*Figure 7.28. Assembly of the sensor and the mounting system seen from opposite corners.*

This set of this photocell and mounting system will be placed in all the machines placed on the line, as this sensor covers all the needs of the process, and the function to be performed throughout the route of both the raw material and the pallets is going to be similar. However, the detection distance covers up to seven metres, as mentioned in the technical specifications in section 7.4.1 Choice of motor, so there will be no problem in that respect. Additionally, obtaining several sensors of the same type is cheaper than obtaining several different ones.

### 7.4.4. PLACEMENT OF THE SENSOR ON THE CHAIN CONVEYOR

As indicated above, the sensors must provide the necessary information to know where the material is on the line at every moment. On the chain conveyor, two sensors have been placed at the entrance of the pallet with wooden slats, i.e. one for each flow of packages, and another two at the exit for the same reason. With these sensors, it is sufficient to know when the material enters, when it is in the machine and when it leaves. The position of all of them together can be seen in figure 7.1, at the beginning of this section. The position of a particular sensor is shown in figure 7.29, including distance

information to the edge of the rectangular tube and to the middle chain structure in each flow.

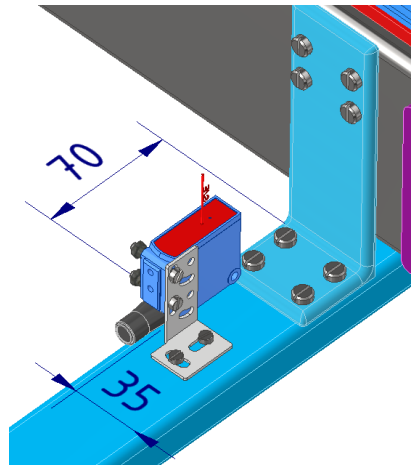

Figure 7.29. Position of a sensor in the chain conveyor.

## 7.5. INDIVIDUAL CHAIN CONVEYOR

In the pallet path there is an area where the pallets are transported one at a time, with a single flow of material. This implies that exactly the same structure is used, but eliminating half of the machine and leaving only three chains, all the elements associated with it, such as the motor, the axle, the sensors and the structural elements. The motor is the same one as the chosen for transporting the pallets without material, as is the object these chains are going to transport. An image of this machine can be seen in Figure 7.30.

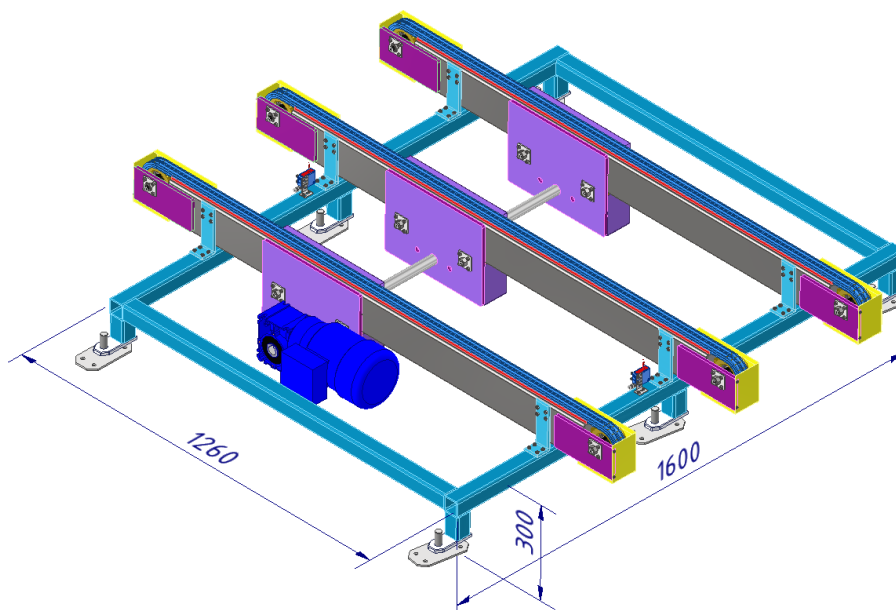

Figure 7.30. Roller conveyor with only one flow of pallets. Dimensions in mm.

## 7.6. CHAIN CONVEYOR ON THE LINE

In the first chain conveyor the material is left from a forklift. The sensors detect the entrance of material. Once the material has left the second chain conveyor because it has been detected by the sensors, the first chain will start moving and put the material in the second chain conveyor. The entrance and exit of the material in both chain conveyors is monitored by the sensors. In the figure 7.31 there is an image of the two existing chain conveyors at the entrance of the line.



*Figure 7.31. Image of the two existing conveyors at the beginning of the line.*

In the Figure 7.32 it is possible to see the roller conveyor that takes the pallets with material out of the line.

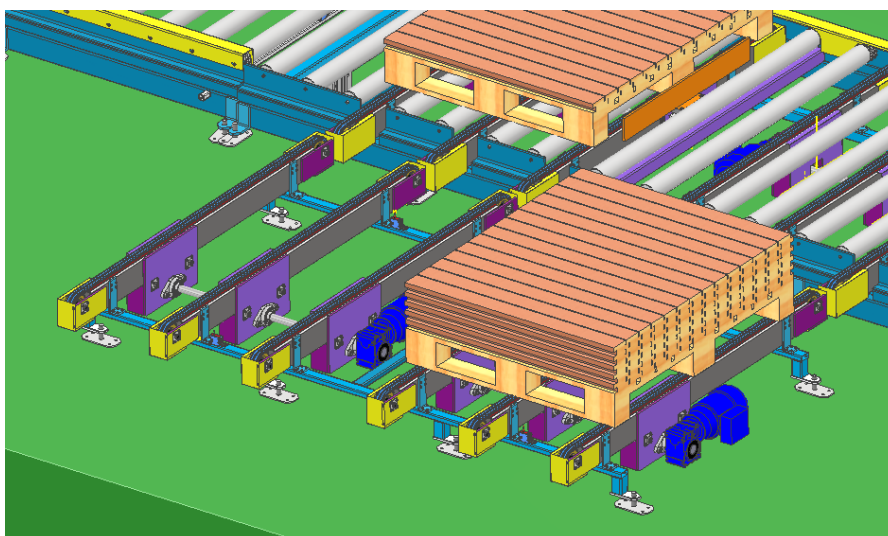

*Figure 7.32. Roller conveyor that takes the pallets with full load out of the line.*

Finally, in Figure 7.33, it is illustrated the position of the three roller conveyors on a row that one after the other transport the pallets without load on their way from the beginning to the end of the line.

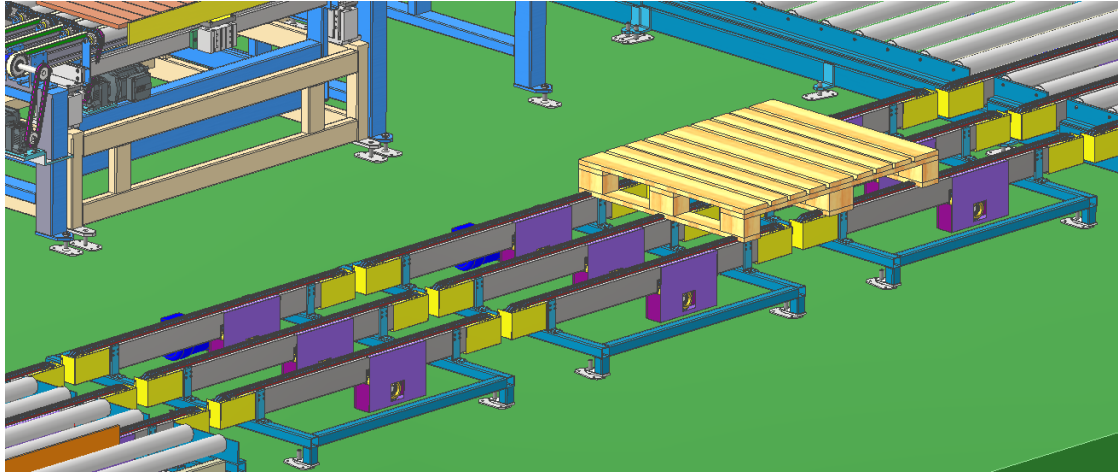

Figure 7.33. Location of the chain conveyors that transport one flow of pallets in the line.

## 8. CHAIN ROLLER ON LIFTING TABLE

The next machine consists of a chain conveyor mounted on a lifting table. The reason why a lifting table is needed is that the next machine is a robot, which has to pick up the pieces of wood, and cannot reach as low as the 300 mm at which the previous chain conveyor is. This is a functional and efficient solution that allows the correct operation of the line.

It should be noted that, obviously, as much as the table can be lowered in height, it is not possible to get the chains to the height of 300 mm above the floor, but it must be done as the previous machine is at that height. The most effective solution is to make a hole in the floor whose dimensions are slightly larger than the table and where it can be placed. In this way, the lift table will be 300 mm above the floor of the rest of the line when it is folded, and up to the height necessary for the robot to pick up every last sheet of wood in the block of 12 in each column.

An image of this machine can be seen in Figure 8.1.

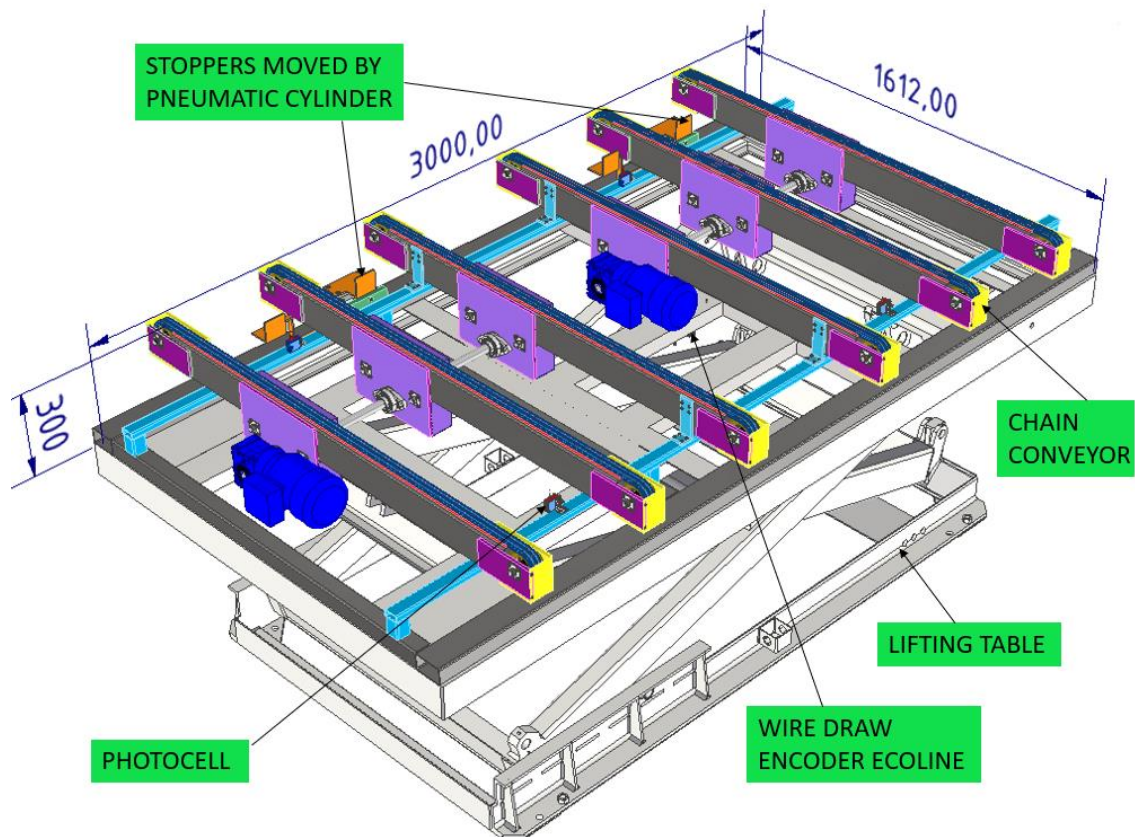

Figure 8.1. Machine consisting of a chain roller on a lifting table.

## 8.1. CHAIN ROLLER

The chains that form the chain conveyor are the same as those used for the previous chain conveyor, as well as the supports for these chains, the motor, its shaft and the oval ball bearing.

The rectangular tubes that support it follow the DIN EN 10210-2 50 x 25 x 3 mm standard and their length is 3000 mm, the same as the lifting table. Under each of these structures are eight square tubes DIN EN 10210-2 50 x 50 x 4 mm of length 60 mm.

These legs are supported by four rectangular cross beams DIN EN 10210-2 - 60 x 60 x 4 mm, 1500 mm long, which connect the two long longitudinal tubes of the same standard and dimensions 100 x 60 x 4 mm.

The photocell sensors are placed in the exact same place as in the previous still chain conveyor.

This set of elements totals 300 mm as already indicated beforehand and can be seen in figure 8.1 above.



## 8.2. LIFTING TABLE

The scissors lift (platform) type DBNA is designed and manufactured by FAMAD for mechanization and automation of transport, loading and unloading operations, forming part of a process line. It is remarkable its strengthened construction which aims at a very harsh work environment. It has a load capacity up to 2.5 tonnes, more than enough for this purpose. An advantage of this type of lift is that it is suitable for multiple applications as it can be equipped with chain or roller conveyors, a rotating table, barriers, flaps and other mechanisms, being possible to obtain different dimensions and heights according to the required needs.

These lifts are inspected according to appendix C of PN-EN 1570:2002 "Safety requirements regarding table lifts". It also has a *CE Compliance declaration* and all the required documents for UDT registration.

The technical data of this scissor lift (platform) are specified in the following chart 8.1.

		DBNA - 1,5t	DBNA - 2,5t	DBNA - 5,0t	DUO - 8,0t
<b>Lifting capacity</b>	t	<b>1,5</b>	<b>2,5</b>	<b>5,0</b>	<b>8,0</b>
<b>Table dimensions (standard)</b>	mm	<b>2000 x 900</b>	<b>2500 x 1000</b>	<b>2800 x 1200</b>	<b>2200 x 5600</b>
<b>Table lifting time</b>	s	<b>47</b>	<b>32</b>	<b>37</b>	<b>75</b>
<b>Maximum lifting height</b>	mm	<b>1100</b>	<b>1600</b>	<b>1650/1750</b>	<b>1500</b>
<b>Height when folded</b>	mm	<b>250</b>	<b>300</b>	<b>400</b>	<b>400</b>
<b>Drive power</b>	kW	<b>1,1</b>	<b>4,0</b>	<b>5,5</b>	<b>7,5</b>
<b>Electric supply</b>	V AC	<b>3/N/PE, 400V 50Hz</b>			
<b>Control voltage</b>	dBA	<b>72-82 (depending on the used pump)</b>			
<b>Mass</b>	kg	<b>650</b>	<b>900</b>	<b>1330</b>	<b>2800</b>

Chart 8.1. Technical data of the scissors lift DBNA - 2,5 t.

An image of the CAD drawing of the hydraulic scissors lift used in Autodesk Inventor can be seen in Figure 8.2.

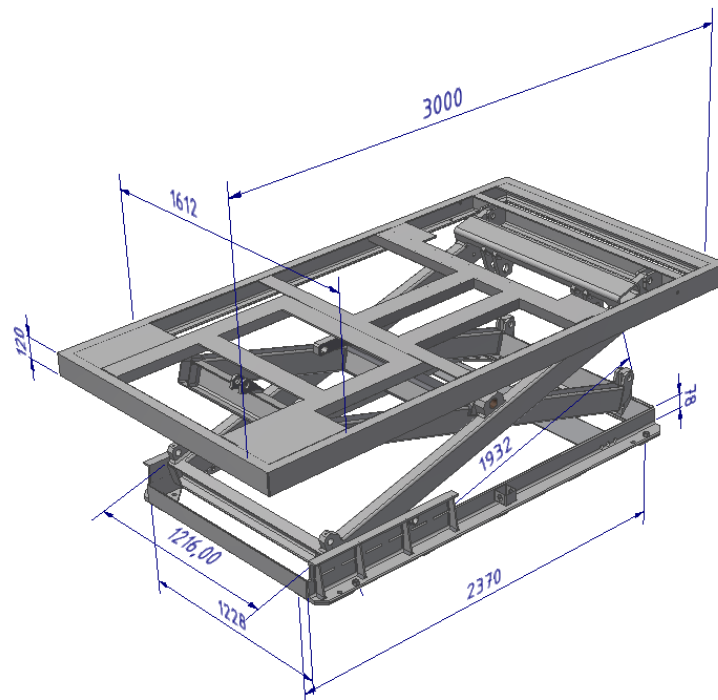

Figure 8.2. CAD Drawing of the scissor lift DBNA – 2.5 t.

The data sheet of the scissor lift DBNA - 2.5 tonnes can be checked in the annex 2 of this project.

Knowing that its folded height is 300 mm, and the chain structure is another 300 mm, the table will need to be placed in a hole in the floor 300 mm deep.

### 8.3. STOPPERS

A stopper is a component that serves to stop the material on the line at a certain place. In this case, they are raised when a pallet enters the chain conveyor, thus stopping the pallets with the load, so that the robot, which is then programmed to pick up the wooden boards, always has the material in the same place on the chain conveyor. Once the table is lowered again with the empty pallet, the stoppers are lowered a few millimetres with the movement of a pneumatic cylinder and resume their journey. A picture of the structure of the stoppers can be seen in Figure 8.3.

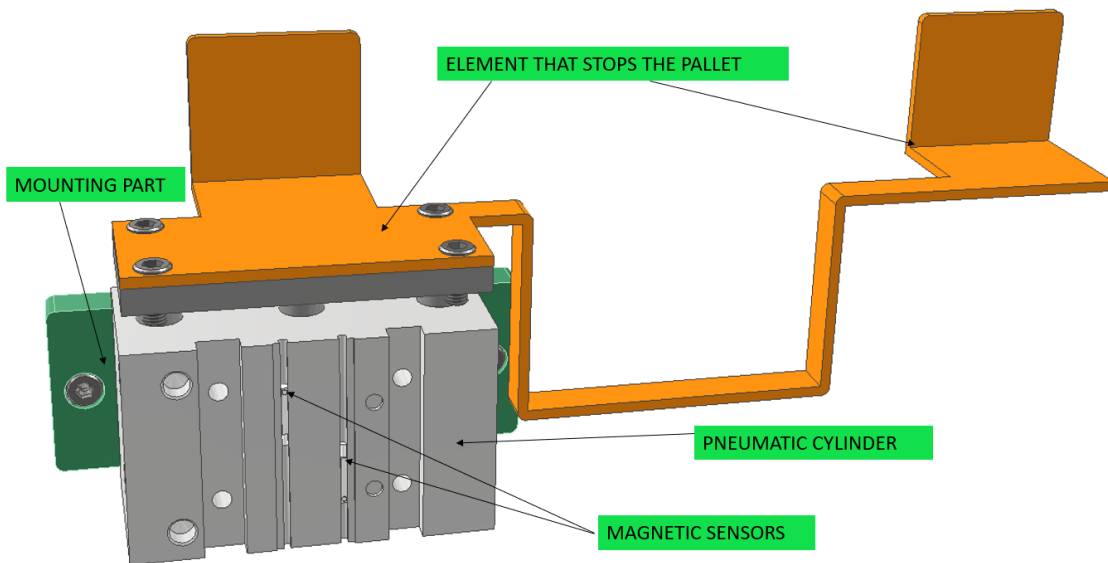

Figure 8.2. Structure of the stoppers of the pallets with material.

### 8.3.1. PNEUMATIC CYLINDERS

The pneumatic cylinders were chosen from SMC. It is a compact cylinder with guides, series MGP. The characteristics of this cylinder are:

- Precise guided movement.
- Compact design and light weight.
- Flexibility for multiple applications.
- 4 types of mountings available: side, bottom, top, side and side with T-slot.
- Magnetic detectors on one side.

Product selection has been as follows:

- Normal accuracy.
- No locking mechanism.
- No special environment required.
- Cushion: rubber bumper.
- No application requirements.

Once these variations have been chosen, parameters such as Bearing Type, Bore Size, port thread type, lube-retainer, stroke size or switch type have to be selected, which are shown in Figure 8.3.



Bearing Type  
M (Slide Bearing) ✓

Bore Size  
Ø20 mm ✓

Port Thread Type  
TF [G] ✓

Lube-retainer  
Without Stable Lubrication Function ✓

Stroke  
30 [20 mm to 400 mm] by 5 ✓

Auto Switch  
M9B--Solid State, Gen. Purpose, 2 Wire, Horizo... ✓

Lead Wire Length  
0.5m [Or None in the Case of No Switch] ✓

Number of Auto Switches  
2 pcs. [Or None in Case of No Switch] ✓

Figure 8.3. Parameters of the Compact Guide Cylinder MGPM80TF-30Z for the stoppers in the lifting table.

The resulting product is therefore called Compact Guide Cylinder MGP-Z, Compact Guide Cylinder MGPM80TF-30Z.

The letters and numbers forming the name of the cylinder type have the meaning shown in the diagram in Figure 8.4.

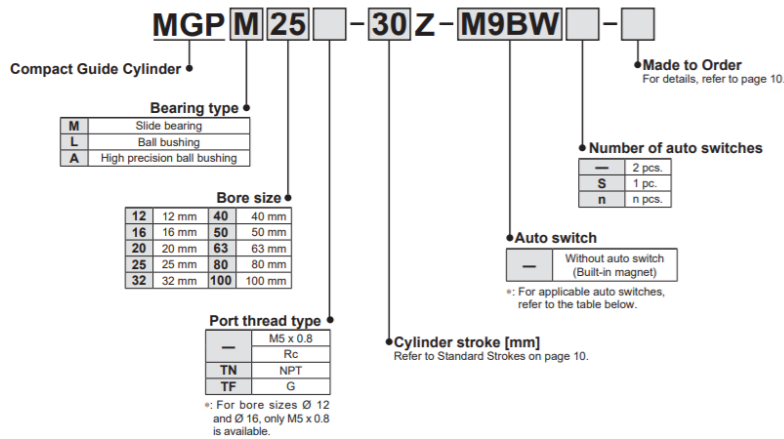

Figure 8.4. Scheme explaining the name of this type of cylinder in the company SMC.

Slide bearings have been chosen, ideal for side load applications such as a stopper where a shock is applied. They have an end lock, which holds the cylinder in the rest position even if the air supply stops. The chosen bore size of 20 mm is sufficient for this application. No stable lubricating function is required. The stroke has been chosen to be 30 mm. The chosen switch is a M9B - Solid state, general purpose with 2 wires and horizontal. The length of the lead cable is 0.5 metres and the number of these magnetic

sensors to be fitted is two pieces. They have two colour indication solid state auto switch. A green light illuminates up at the optimum operating range. The light will be red in case of any disturbance, as external magnetic fields or temperature changes. An appropriate setting of the mounting position can be performed without mistakes.

In the following Figure 8.5 you can see the real cylinder chosen with the magnetic sensors on the front rails.



*Figure 8.5. Imagen of a real pneumatic compact guide cylinder MGPM80TF-30Z.*

The sensors work as followed: the cylinder has magnetic object inside that goes up and down with the moving part of the cylinder. The magnetic sensors are connected to electricity, positive on one side and negative in the other. When the magnet inside moves, the signal these magnetic sensors emit changes, and that is how the position of the cylinder is calculated.

For more detailed information on this cylinder, such as all standard specifications, cylinder drawings and materials of all cylinder parts, please refer to the datasheet of the compact guide cylinder MGPM80TF-30Z in annex 2.

It is possible to download this component in CAD format. This CAD drawing with some relevant dimensions is shown below, Figure 8.6.

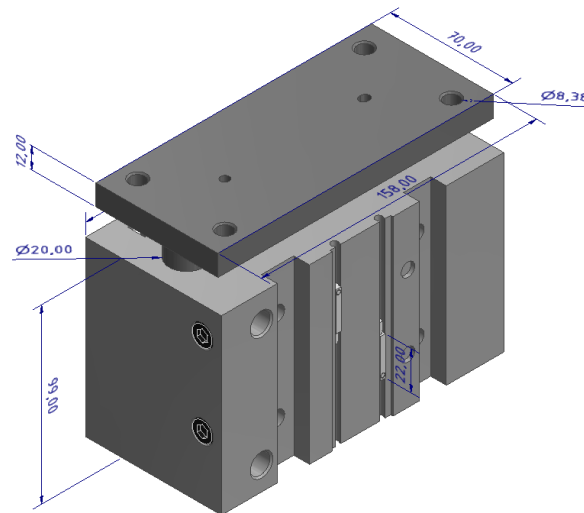

Figure 8.6. pneumatic compact guide cylinder MGPM80TF-30Z with two switches.

The movement that this pneumatic cylinder can make I am going to set it to 30 mm. In Autodesk Inventor I can create a constraint for this movement as follows:

- I select the Constrain option.
- Select the round surface that acts as a stop on the moving part, as indicated by the blue arrow on the left in Figure 8.7.
- Select the surface inside the cylinder that stops at the top, and can be seen if the cylinder is cut, as indicated by the red arrow in Figure 8.7.

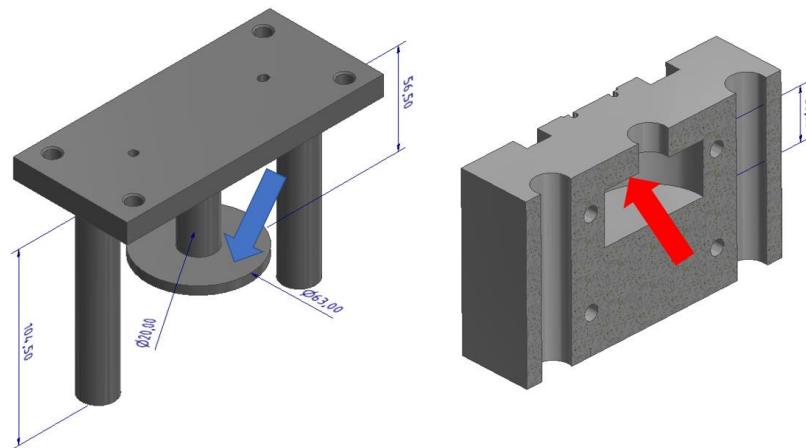

Figure 8.7. On the left, moving part of the cylinder. On the right side, half view of the still part of the cylinder. The arrows indicate the surfaces which should be selected for applying the constraint with movement.

- In the Place Component Window that I have open, at the bottom, I select the maximum and minimum boxes, and type maximum 30 mm and minimum 0 mm. This can be seen in Figure 8.8.

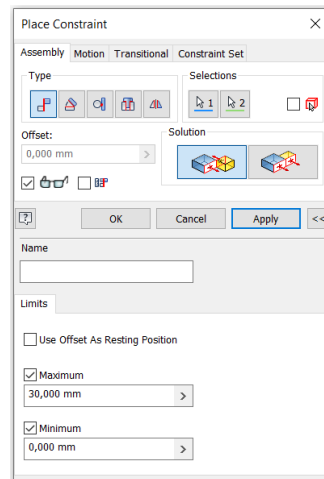

Figure 8.8. Window for placing constraint where the restriction of movement has a maximum and a minimum.

### 8.3.2. MOUNTING PART

The mounting part consists of a flat panel of dimensions 220 x 800 mm and thickness 20 mm, with 3 mm corner fillets. It is forest green in colour. It has four holes of 11 mm diameter forming a rectangle and spaced 80 mm apart on the longest side and 52 on the shortest side, to fit into the holes provided in the cylinder to fit them with screws DIN 6912 M10 X 20 mm long. Two other equal holes at 190 mm distance are located on the central major axis of the rectangle, but they are made in the other direction, in order to fit the cylinder to a surface on that side. A close-up view of this part can be seen in Figure 8.9.

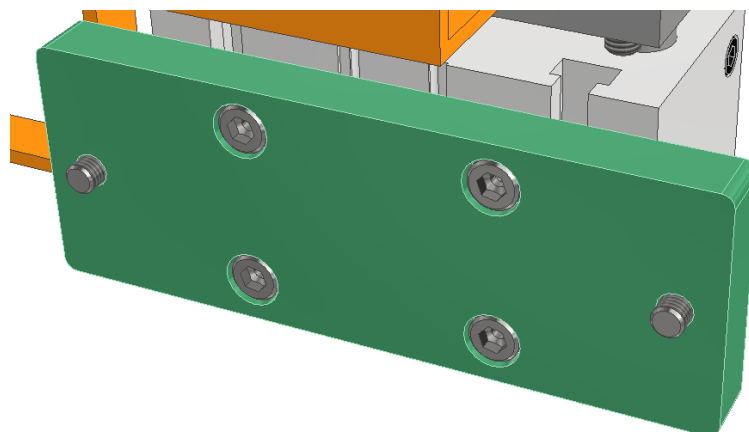

Figure 8.9. Green mounting plane of the cylinder with bolts.

### 8.3.3. ELEMENTS THAT STOP THE PALLET

The orange structure is built to stop the paddle from two different places, so that it does not change the straight position, and avoiding the chain in the middle of it. This is the reason for its shape. On the part that is attached to the moving part of the pneumatic cylinder there are four holes of diameter 8.4 mm and spaced 130 mm on the longer side and 50 on the shorter side, fixed with DIN 6912 M10 x 20:7 screws. The distance between the cylinder and the part touching the pallet has been calculated to stop the pallet right in the centre of the chain conveyor. A picture of this orange structure with some dimensions can be seen in Figure 8.10.

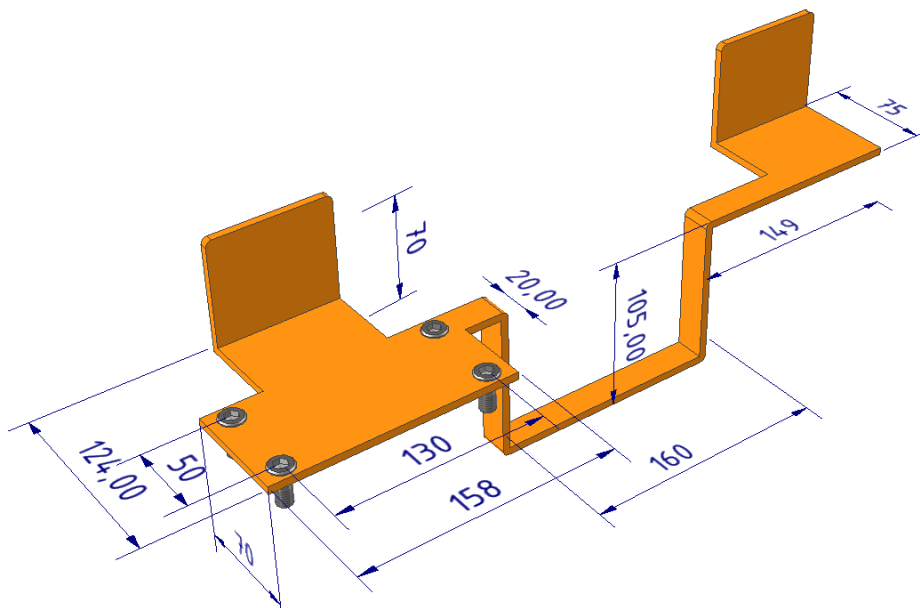

Figure 8.10. Structure that stops the pallets with material which is attached to the cylinder.

## 8.4 SENSORS

Sensors placed on this machine, or near it interacting with the material on it, are necessary for several reasons:

- The table must go up when the material on it with a full oak slat pack is on it and is in its lowest position.
- The table must be lowered when there is only an empty pallet on it and its position is the highest.
- The robot, which is the next machine to interact with the wooden slats, must pick up the wooden slats at the programmed height, regardless of whether the slat is

the first one on the pallet, one in the middle or the last one. To do this, the table will go up a little each time the robot picks up a complete row of wooden slats.

- The pallet must be stopped in the middle position of the table with the help of the stoppers. These elements are raised and lowered by cylinders, and it must be known when they have to be raised and lowered, as well as when they are in the extended or lowered position.
- It must be known when the pallet with material enters and when the empty pallet leaves, so that the previous and the next machine know when it can start up.

#### 8.4.1. SENSOR FOR DETECTING THE HEIGHT AT WHICH THE TABLE IS POSITIONED

The positioning of the lifting unit can be handled by an encoder. Absolute encoders are going to be used here. The chosen encoder is from the SICK catalogue, model wire draw encoder EcoLine.

With EcoLine wire draw encoder sensors, you have a number of advantages:

- You save space and money thanks to the slim mechanics. The advanced programming options lead to a reduction in storage and save money.
- The analogue interface with an intuitive learning function speeds up commissioning and allows easy integration into the system. The use of an inexpensive interface card is also possible.
- With their high resolution and repeatability, they ensure that the positioning commands are executed with high precision.
- The special nozzle protects the measuring wire from damage caused by vibrations.
- It has an extremely impact-resistant and temperature-resistant plastic housing, which is also lightweight.

Within the wire draw encoder EcoLine group, the type BCG08-P1BM0336 has been chosen. The part number is 1052618. The measuring range of this encoder is from 0 to 3 metres, which is more than enough as the chosen table does not reach these measurements. It is an incremental encoder, with a resolution of 0.03 mm. Communication with the interface is via PROFIBUS DP. It is a programmable encoder, with an estimated average cycle of life of 60 years. It has a CE compliance declaration. Some of these features can be seen in Chart 8.2.



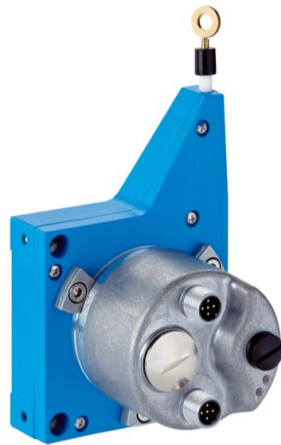

Figure 8.12. Real image of a wire draw encoder EcoLine, type BCG08-P1BM0336.

A CAD drawing of this sensor has been obtained, and a bracket has been created to place it on the underside of the table to hold it in place. This is shown in Figure 8.13.

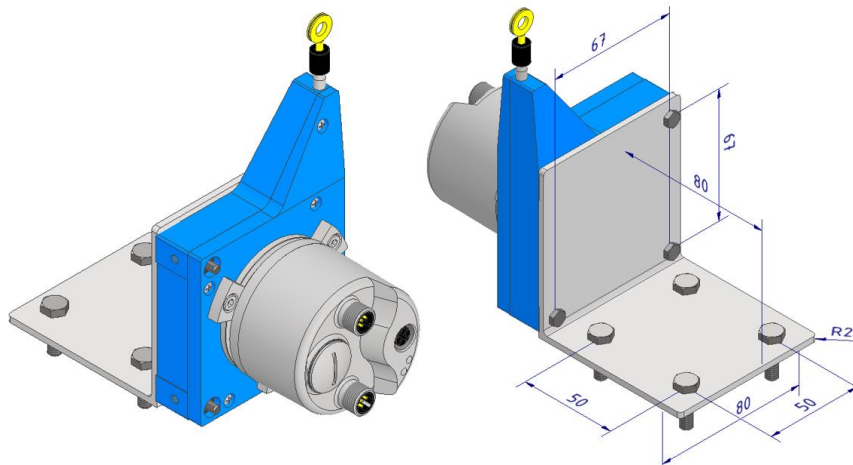

Figure 8.13. Sensor with fixing part, on the left view from the front and on the right opposite side with measurements.

This sensor is placed under the lifting table and looking at the floor, so it can always measure the distance without any disturbing object on its way. This is shown in figure 8.14.



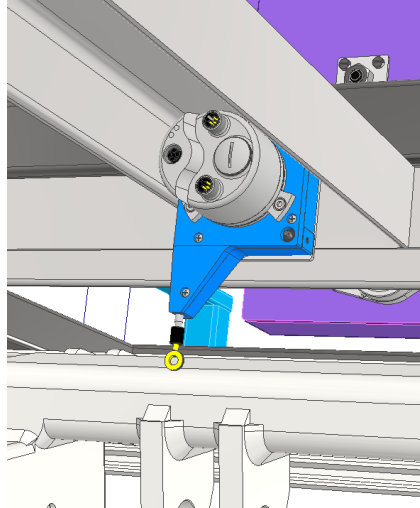

Figure 8.14. wire draw encoder EcoLine, type BCG08-P1BM0336 under the lifting table.

#### 8.4.2. SENSORS FOR DETECTING THE PRESENCE OF WOODEN SLATS ON THE PALLET

A fibre optic sensor has been chosen to detect the presence or absence of lamellas on the pallet. A fibre optic sensor contains an optical fibre connected to a light source, whose function is to facilitate detection in confined spaces, or when a small profile is convenient. They can be used as bus systems: this leads to a synchronisation in the pulse transmission pattern of the connected devices. The advantage is that mutual interference between several sensors in close proximity is avoided.

Within these sensors, the GLL170 group has been chosen from the SICK catalogue. These sensors have a number of advantages:

- Easy to use and handle.
- Reliable detection even in fast processes.
- Easy to adjust with a teach-in button.
- The sensor parameters can be flexibly adapted to a wide range of applications and parameter control is simple.
- Robust housing for mounting outside the robot cabinet.
- Quick and easy mounting with the supplied fastening elements.
- Can be combined with other fibres for multiple applications.
- It has a CE compliance declaration.

The type of fibre optic sensor within the group is GLL170T-B434. A picture of this sensor can be seen in figure 8.15.



Figure 8.15. Real picture of the fiber-optic sensor GLL170T-B434.

It is of the Stand-alone type. Its dimensions are 10 x 31.7 x 72.5 mm. The design of the housing through which the light is emitted is rectangular. Its measuring range is up to 1320 mm, which is more than enough, as the sensor will be placed at about 200 mm from the table. The cable material is PVC. It is programmable for a delay. Its estimated average lifetime is 300 years. The input is Teach-in. Some of these and other characteristics can be seen in Chart 8.3.

<b>Type</b>	Stand-alone
<b>Dimensions (W x H x D)</b>	10 mm x 31.7 mm x 72.5 mm
<b>Housing design (light emission)</b>	Rectangular
<b>Sensing range max.</b>	0 mm ... 400 mm, Proximity system <sup>1) 2)</sup> 0 mm ... 1,320 mm, Through-beam system <sup>3)</sup>
<b>Sensing range</b>	0 mm ... 350 mm, Proximity system <sup>1) 2)</sup> 0 mm ... 1,100 mm, Through-beam system <sup>3)</sup>
<b>Type of light</b>	Visible red light
<b>Light source</b>	LED <sup>4)</sup>
<b>Wave length</b>	632 nm
<b>Adjustment</b>	Teach-in button Cable Plus/minus button
<b>Indication</b>	Display
<b>Display</b>	Status LEDs, 4-digit digital display, display selectable between percentage value, absolute digit value and bar display / display of parameters

<sup>1)</sup> Object with 90 % reflectance (referred to standard white, DIN 5033).

<sup>2)</sup> LL3-DK06.

<sup>3)</sup> LL3-TB02.

<sup>4)</sup> Average service life: 100,000 h at T<sub>0</sub> = +25 °C.

Chart 8.3. Technical details of the fibre optic sensor GLL170T-B434.

Figure 8.16 below shows a drawing of the views of the sensor with its dimensions.

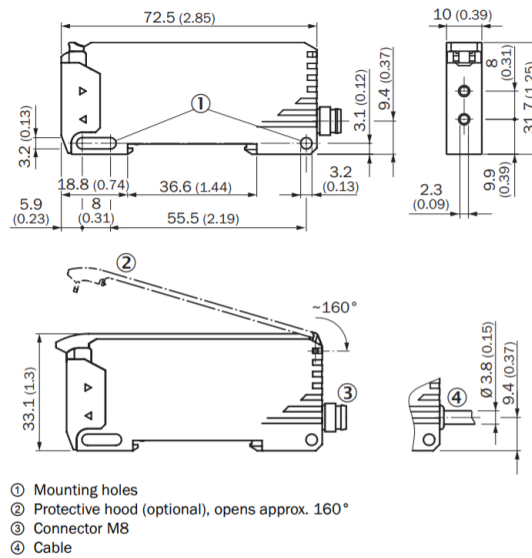

Figure 8.16. Dimensional drawing of the fiber-optic sensor GLL170T-B434. Dimensions in mm (inch).

For more detailed information on the mechanics or electronics of the device, as well as further characteristics, please refer to its data sheet in annex 2.

To mount this sensor, a system from the same company has been chosen. It is a mounting bracket type BEF-WLL180. It is made of steel and has no mounting hardware. It is designed for this type of sensor. A photograph of this mounting system can be seen in Figure 8.17.



Figure 8.17. Mounting system BEF-WLL180 suitable for fibre-optic sensor type GLL170.

The dimensions of this mounting sensor are shown in Figure 8.18.

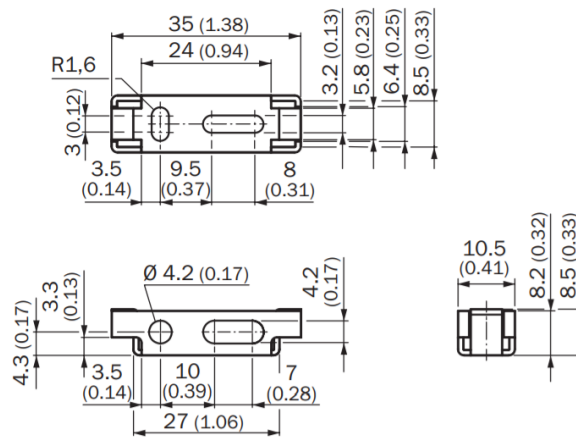

Figure 8.18. Dimensional drawing in mm (inch) of the mounting system BEF-WLL180.

In order to know more about this mounting system, check the datasheet in the annex 2.

Both the fibre optic sensor and its mounting system can be downloaded in CAD drawing from the SICK website.

This sensor with the mounting system has been mounted on the floor of the process line, as I want it to be stationary, not to be raised and lowered by the lifting table. For its mounting, it has been placed on a 25x25x5 mm plane with the holes placed at 17.5 mm distance in order to be able to adjust to the mounting system. The screws used are socket headed, DIN 7984 M3 x 6 mm.

The height of the structure should be such that the last row of wooden boards is displayed at a height of 900 mm, while the table is rising so that this is maintained. A close-up picture of the sensor in its structure and of the complete structure can be seen in Figure 8.19.

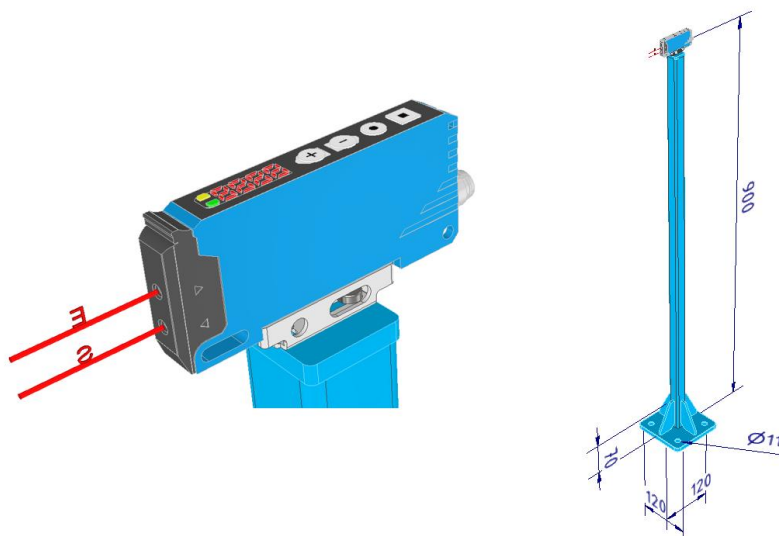

Figure 8.19. On the left, fibre-optic sensor on its structure. On the right, image of the full structure with dimensions in mm. Drawings from Autodesk Inventor.

Figure 8.20 shows an image of the position in which these sensors are placed on the line, which is diagonally from the corners where the pallets with the oak boards enter.

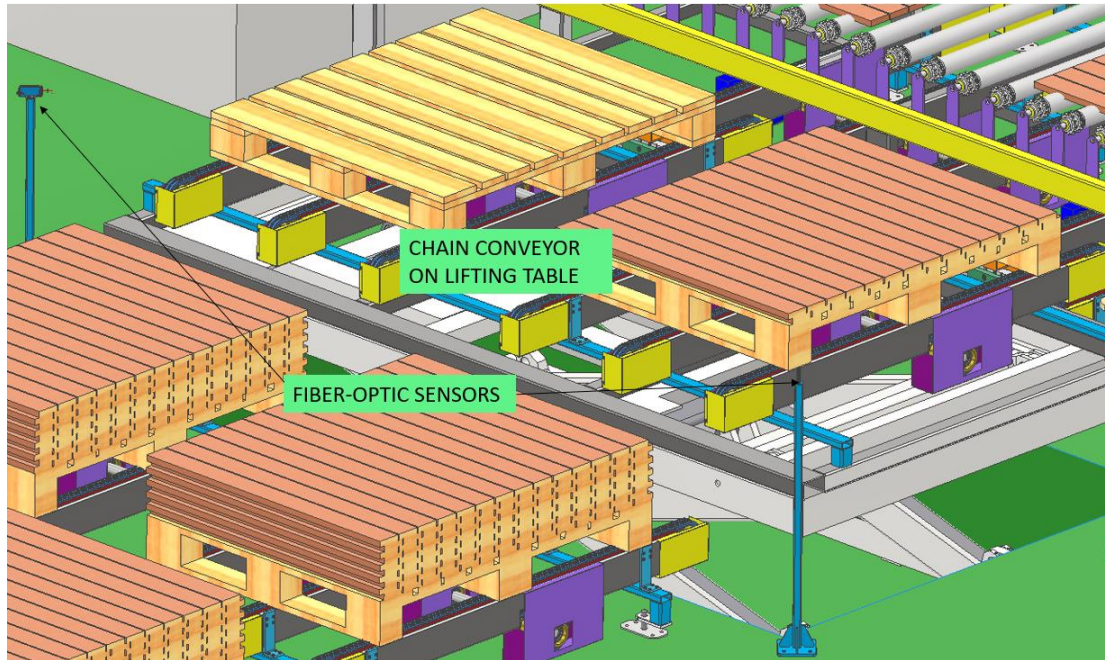

Figure 8.20. Fiber-optic sensors in the line detecting the wood sheets on the pallets on the chain conveyor on the lifting table.

The way it works is as follows: the two fibre optic sensors, one for each column of 14 wooden slats, detect the object at a height of 900 mm. The robot that follows picks up the last row of wooden slats. The sensors now detect nothing, so they move the table up 5 mm to place the next row of wooden slats in the same position. When the last row of wooden boards is picked up, and the encoder explained in the previous section (8.4.2. sensor to detect the height at which the table is located) detects the maximum height at which the table must reach because the pallet is empty, the table lowers until it is again at the height of the pallet transport, 300 mm above the floor. This maximum height at which the table no longer rises, measured with respect to floor level, will be  $900 \text{ mm} - 150 \text{ mm of the pallet} - 5 \text{ mm of the last row of wood sheets} = 745 \text{ mm}$ . As explained in section 8.2. LIFTING TABLE, the table can be raised up to a maximum of 1600 mm. Bearing in mind that it is in a 300 mm hole, this will be 1300 mm above floor level. It is checked that the table is suitable for this application.

### 8.4.3. SENSORS FOR DETECTING THE MATERIAL INFEED AND OUTFEED OF THE MACHINE

The sensors used for material infeed and outfeed are exactly the same as in the chain conveyor: photoelectric sensor WL12-3V2431 from the company SICK, and placed in the same place. For further information, please refer to section 7.4 *Sensors on the chain conveyor*.

### 8.4.4. MAGNETIC SENSORS FOR DETECTING THE CYLINDER POSITION

Magnetic sensors are used to monitor the position of magnetic cylinders: whether the moving part is up or down. The sensor detects the field of the magnet integrated in the piston through the actuator wall. The selected magnetic cylinders are equipped with grooves that allow magnetic sensors to be fitted. These sensors are detected through the cylinder wall. As they are non-contacting, there is no rubbing, no bouncing and the switching points are clean and therefore operate without wear. This offers a high level of safety and operational reliability, even at high speeds.

The M9B-Solid State Switch, of General purpose, 2 Wire, horizontal, has been chosen. There are two pieces of auto switches, two in each groove on one of the two sides of the cylinder. The lead wire length is 0.5 metres. Information on this sensor can be found in the datasheet of that cylinder (compact guide cylinder MGPM80TF-30Z) in annex 2.

A close-up image of the sensor can be seen in Figure 8.21.

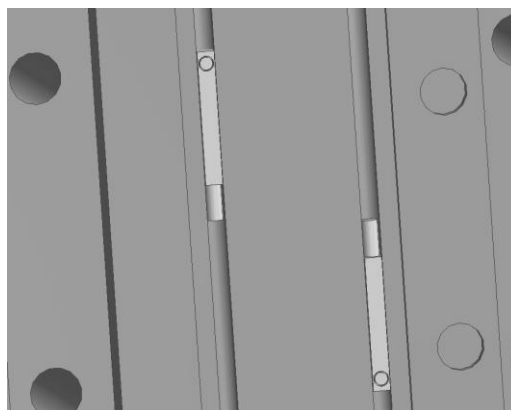

Figure 8.21. Two pieces of M9B--Solid State, Gen. Purpose, 2 Wire, Horizontal in cylinder.

## 9. ROBOT WITH VACUUM SYSTEM

The next machine that handles the wooden slats is a robot with a vacuum system that takes the slats that are on the pallets on the chain conveyor on the lifting table and places them on a roller conveyor. It is made up of three important components that I will explain independently: the robot, the vacuum gripping systems and the structure that joins both elements. In addition, the whole structure rests on a table, as the robot must be elevated to be able to handle the material, because the robot is on a corner of the lifting table and it would be impossible for it reaching the wooden elements from the pallet that is further.

### 9.1. ROBOT IRB 760

The robot chosen is a robot IRB 760 from the company ABB. A real image of this robot can be seen in the Figure 9.1.



*Figure 9.1. Real image of the IRB 760 robot.*

The IRB 760 is the fastest robot of its kind. It is capable of making cycle times shorter and raising the productivity of the automatic line. This 4-axis robot can move and rotate large and heavy materials at high speed carefully. Its design is compact, which makes it easy to fit in process lines. It has a reach of 3.2 meters and a 450 kilograms payload capacity, which enables it to lift heavy objects. Its high torque wrist and the high reach area allows it to achieve 880 cycles per hour at full load.



Making use of the patented movement control software, QuickMove and TrueMove developed by ABB, the IRB 760 family ensures high accuracy and smooth movements on its work, which means that every material will be taken of good care without losing cycle time.

Its design is robust and rigid. It is manufactured following the automotive industry standards. Both facts ensure high uptime and low maintenance costs. The integrated process cabling helps extending the life of the products and reducing wear. The product includes a warranty package where ABB experts motor robots and suggest optimized the robot's performance thru advance services which will lead to an increasement of productivity and maintenance high OEE.

The ABB offline simulation and programming is RobotStudio, that allows robot programming to be done without stopping the automatic line. RobotStudio provides the tools to increase the profitability of the robot system by letting the programmer perform tasks such as training, programming and optimization without disturbing production.

The main applications of this robot are full layer palletizing, material handling, press tending, palletizing and depalletizing.

The dimensions of the robot and the working area are explained in the Figure 9.2.

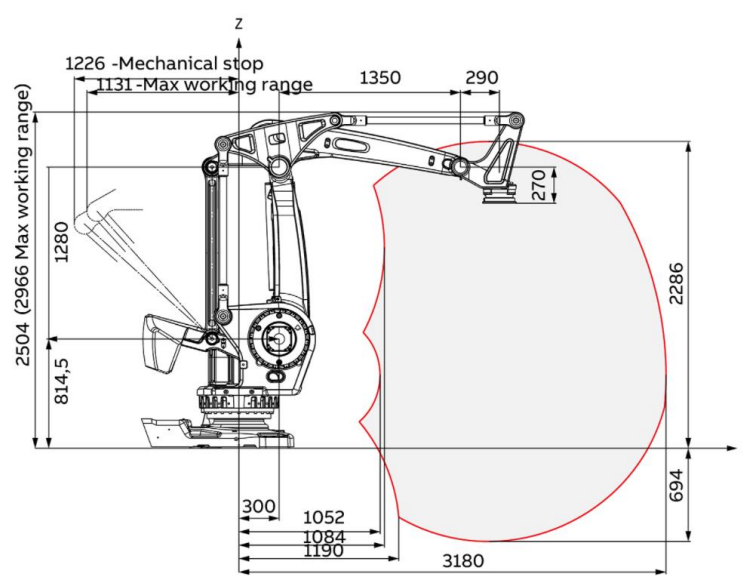

Figure 9.2. Working range and dimensions of the robot IRB 760.

The specifications of the robot itself can be checked in the Chart 9.1.



Robot version	Reach (m)	Handling capacity (kg)
IRB 760	3.18	450
IRB 760PT	3.18	450

Protection	IP67
Number of axes	4
Mounting	Floor mounted
Controller	IRC5 Single cabinet, IRC5 Dual cabinet
Integrated power signal supply	Optional
Integrated air supply	Optional

Robot version	Position repeatability RP (mm)	Path repeatability RT (mm)
IRB 760	0.05	0.80

Axis	Working range	Max. speed
1	+180° to -180°	85°/s
2	+85° to -42°	85°/s
3	+120° to -20°	85°/s
4*	+300° to -300°	160°/s

\* +67 rev. to - 67 rev. max.

Chart 8.9. Specification of the IRB 760 robot.

An CAD drawing can be downloaded from the website, and the robot obtained in Autodesk Inventor is shown in Figure 9.3.

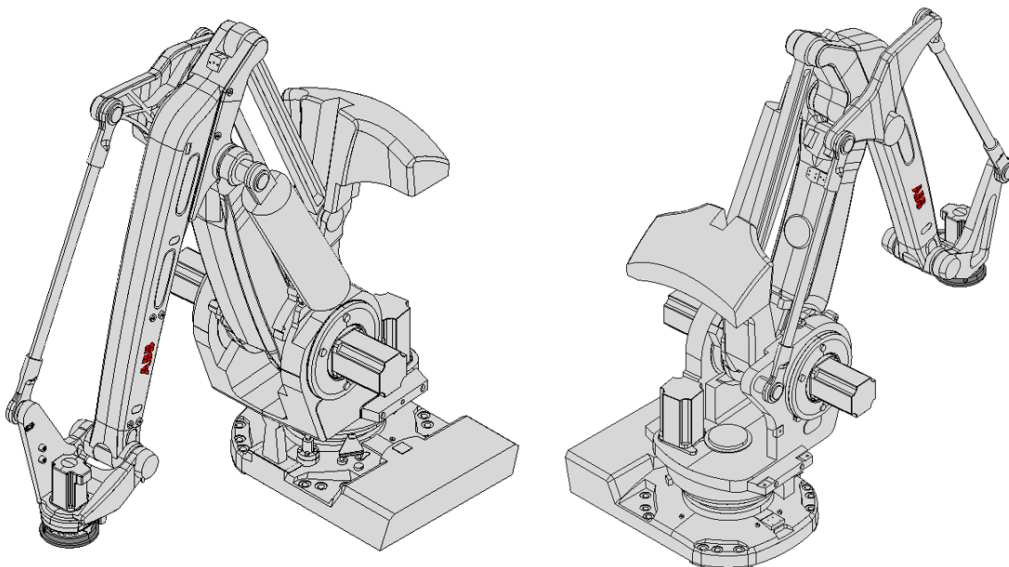

Figure 9.3. IRB 760 robot, CAD drawing in Autodesk Inventor, views from to opposite sides.

In order to know more about mechanical and electric specifications about the IRB 760 robot, as well as general information, the datasheet is available in annex 2.

## 9.2. VACUUM GRIPPERS

The vacuum grippers from the company Kenos, a part of the Piab group, are designed and optimized for various applications. The integrated vacuum generation is a modular multi-stage COAX ejector of easy maintenance and an energy efficient ejector technology. The number of ejectors can be increased even after installation.

The KVG series are a flexible solution for handling products with different shapes and dimensions. The double technology that has valves and flow reducers allows to fulfil many industrial sector applications. Check valves require smaller vacuum pump, still maintaining the vacuum level even if the full surface of the gripper is not covered. It provides large vacuum flow in relation to energy consumption. The mat of the KVG gripping system is made of a technical foam, FDA mat approved available, with different pitch holes and thickness. It can be equipped with integrated COAX cartridges or connectors for external vacuum source. The industrial applications of this vacuum gripping system are wood, plastic, glass, packaging, food, electronics, etc. It has a general purpose.

A construction schema of this vacuum gripping system can be seen in Figure 9.4.



*Figure 9.4. Construction scheme of KENOS KVG series vacuum gripping system.*

Some characteristics must be selected:

- The length 1100 mm, in order to catch one whole row of 24 wood sheets at the same time. The rest of the parameters adjusted are shown in Figure 8.5.
- The width 120 mm.
- Type foam.

- Thickness of the foam: 2 – 20 mm. The standard choice is 20 mm. Thicker foams would be needed when greater compression is required, but the wood elements are not that heavy.
- With filter, that is recommended for dirty environments and with flow reduction technology.
- Pattern step 6, suitable for small pieces larger than 25 mm, like very narrow strips of wood.
- Technology CVL, the standard choice. It is suitable for airtight material or low porous material like wood.
- Vacuum generator S8, with 8 cartridge Si32-3.
- Type of valve configuration V1: solenoid valves 24 Vcc, Normally Closed (NC), vacuum on/off valve, without Blow-off valve.
- Monitoring M3, vacuum gauge.

According to these values, the main technical specifications are the following shown in Chart 9.2.

#### Technical data

Description	Unit	Value
Feed pressure, max.	psi	101.5
Temperature range	°F	32-122
Weight	lb	21-26
Material	-	Al, EPDM, NBR
Noise level	dBA	70
Connection, compressed air	-	G 1/4"

#### Technical data, foam

Description	Unit	Value
Material	-	EPDM

#### Vacuum flow

Feed pressure pump / nozzle	Air consumption per pump	Vacuum flow (scfm) at different vacuum levels (-inHg)								Max vacuum
		0	3	6	9	12	15	18	21	
psi	scfm									-inHg
87.0	3.71	101.6	59.36	44.08	28.8	15.28	10.16	8.48	5.92	22.1

#### Gripping force data

Force, lbf, at different vacuum levels (-inHg), gripper with foam				
8.9	11.8	14.8	17.7	20.7
205	273.4	341.7	410.1	478.4

Chart 9.2. Technical data of KENOS KVG120 vacuum gripping system.

The views and dimensions of the vacuum gripping system are illustrated in Figure 9.5.

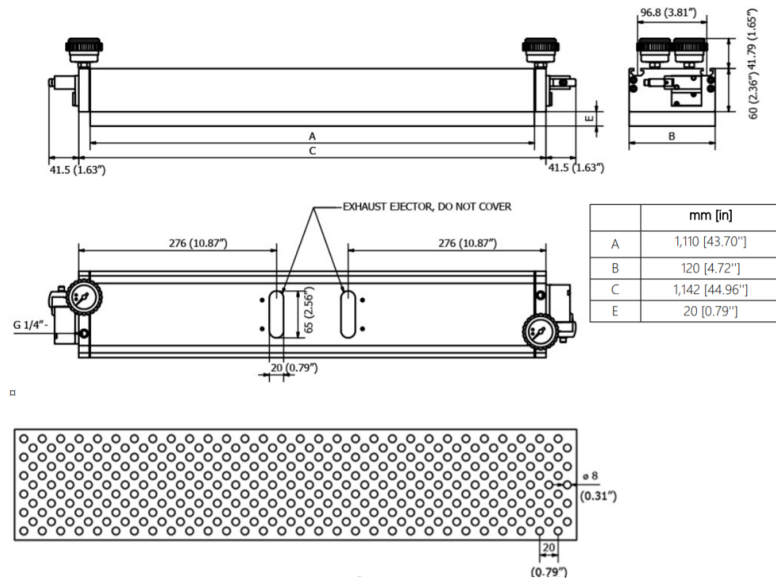

Figure 9.5. Dimensional drawing of KENOS KVG120 vacuum gripping system. Dimensions in mm (inch).

The pneumatic diagram of the vacuum gripping system can be seen in Figure 9.6.

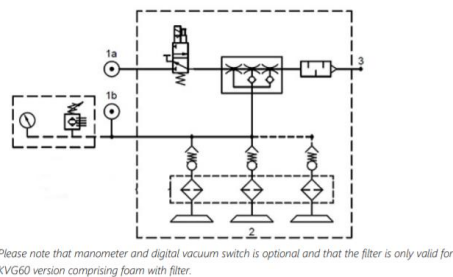

Figure 9.6. Pneumatical diagram of KENOS KVG120 vacuum gripping system.

In the annex 2 the datasheet of this KENOS KVG120 vacuum gripping system is available with more details, as the electric and mechanics information.

It is possible downloading the CAD drawing from the PIAB AB website. In Figure 9.7 there is the final 3D drawing used in Autodesk Inventor.

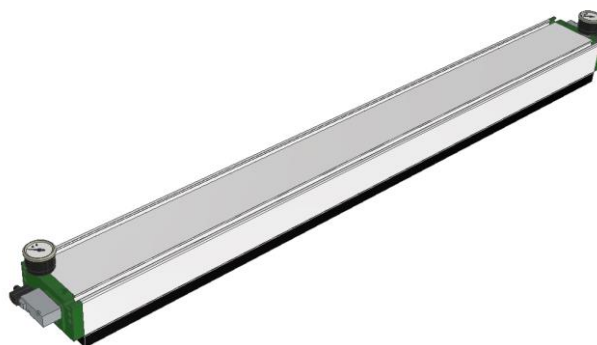
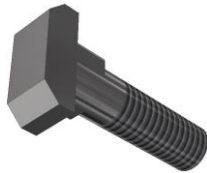

Figure 9.7. Image of the 3D CAD drawing of KENOS KVG120 vacuum gripping system in Autodesk Inventor.

### 9.3. CONNECTING STRUCTURE OF THE ROBOT AND THE VACUUM GRIPPING SYSTEMS

The vacuum gripping system must be joined to the ABB robot by some structure. It is remarkable that there should be two vacuum grippers, due the necessity of taking from the pallets both rows of 14 wooden elements each at the same time.

Firstly, its necessary a structure to hold the vacuum grippers. As it can be noticed in Figure 9.7, the gripper has two slots in both sides which purpose is holding it to another structure. It is possible to introduce there DIN 188 M8 x 30 mm bolts, which has the ideal shape for the slot, as it can be seen in Figure 9.8.



*Figure 9.8. 3D drawing of a DIN 188 bolt in Autodesk Inventor.*

That fastener can be joined to a DIN 1025 – IPE 80-949 mm I - beam structural shape with a DIN EN 1666 M8 x 1mm hex – flanged nut.

The I-beam structural shape can be welded to a pair of DIN EN 10210-2 -50 x 25 x 3 mm rectangular tube structural shapes of 680 mm long, connected with three DIN EN 10210-2 – 50 x 50 x 4 mm square tubes.

On top of this structural shapes there is a plane which dimensions are 550 x 400 mm and thickness 10 mm, and 12 holes of 14 mm diameter distributed around a circle which radius is 120 mm.

Above these holes there is a cylindrical structure with bigger diameters in the two bases. In the base that joins to the previous plane explained the diameter is 250 mm and it is connected with twelve DIN 6912 M14 x 20 mm bolts. The opposite base has a diameter of 300 mm and is joined to the robot with the same bolts but length 40 mm instead of 20 mm.

An image of this structure with its dimensions can be seen in Figure 9.9.

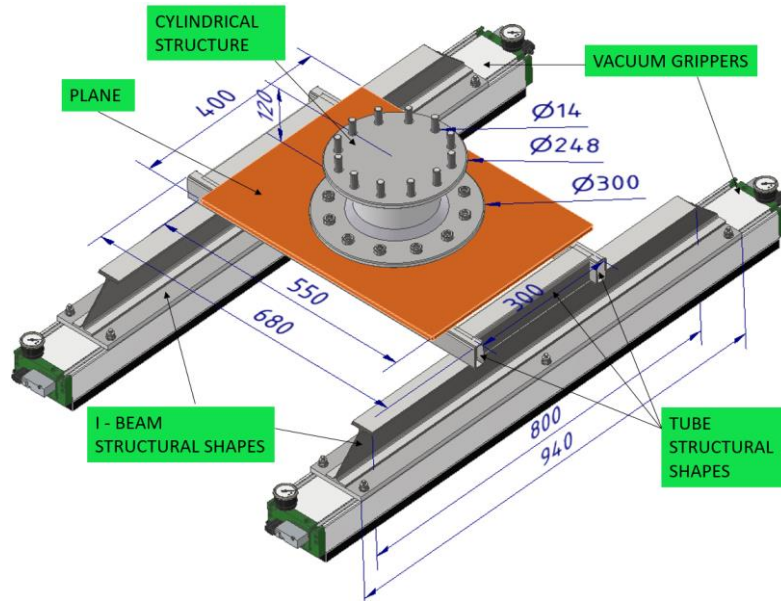

Figure 9.9. Structure with to vacuum grippers that joins them with the IRB 760 robot.  
Dimensions in mm.

#### 9.4. TABLE FOR THE ROBOT

The robot must be higher than the normal floor due to it is situated on a corner of the lifting table, and it would be impossible for it reaching wooden sheets on the opposite side if it did the movement from the floor. Consequently, a construction is necessary for elevating the robot and the structure it has.

A table has been designed, considering the sides of the base of the robot. The dimensions of the plane where the robot is located are 1200 x 920 x 10 mm. There is a similar plane on the opposite side, separated by four square DIN 59 410 tubes, with dimensions 200 x 200 x 10 mm, situated in the corner, and one bigger DIN 59410 400 x 400 x 20 mm in the middle. There area to planes connecting the tubes on the corner on the longer sides. The total height of the lifting table is 845 mm. An image of this table is illustrated in Figure 9.10.

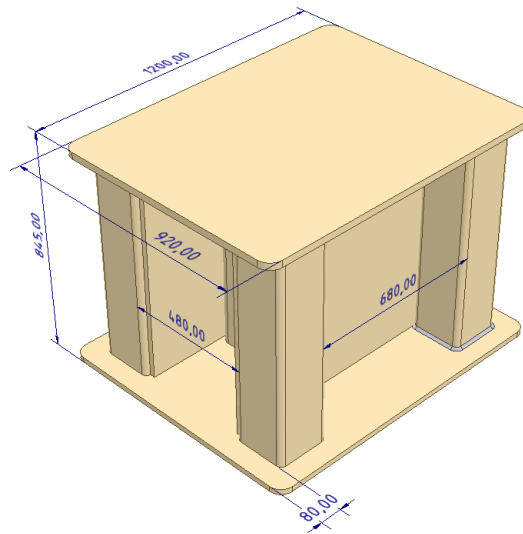

Figure 9.10. Image of the table that elevates the robot with dimensions (mm).

## 9.5. ROBOT WITH VACUUM GRIPPERS IN THE LINE

The robot is programmed to do the necessary movements. has two paths to follow: one for the pallet closest to it and another for the pallet furthest away, with the roller conveyor as its destination. The height at which it picks up the material does not have to vary, as it is the lifting table that is responsible for placing the last row of wooden slats at the same height. The vacuum grippers must start working when they are in the position to pick up the 14 sheets of wood each from a pallet, and they must stop vacuuming and release the sheets of wood when they are in the right position on the roller conveyor. In Figure 9.11 an image of the robot located in the line can be seen.

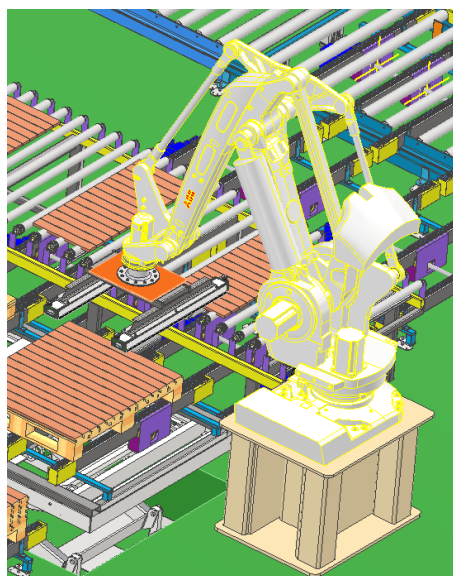

Figure 9.11. The IRB robot with the vacuum grippers on a table located in the line.



## 10. ROLLER CONVEYOR BEFORE GRINDING MACHINE

This roller conveyor has the function of transporting the wood sheets inside the grinding machine, so it must have the same height as it, 900 mm. In Figure 10.1 the roller conveyor is shown.

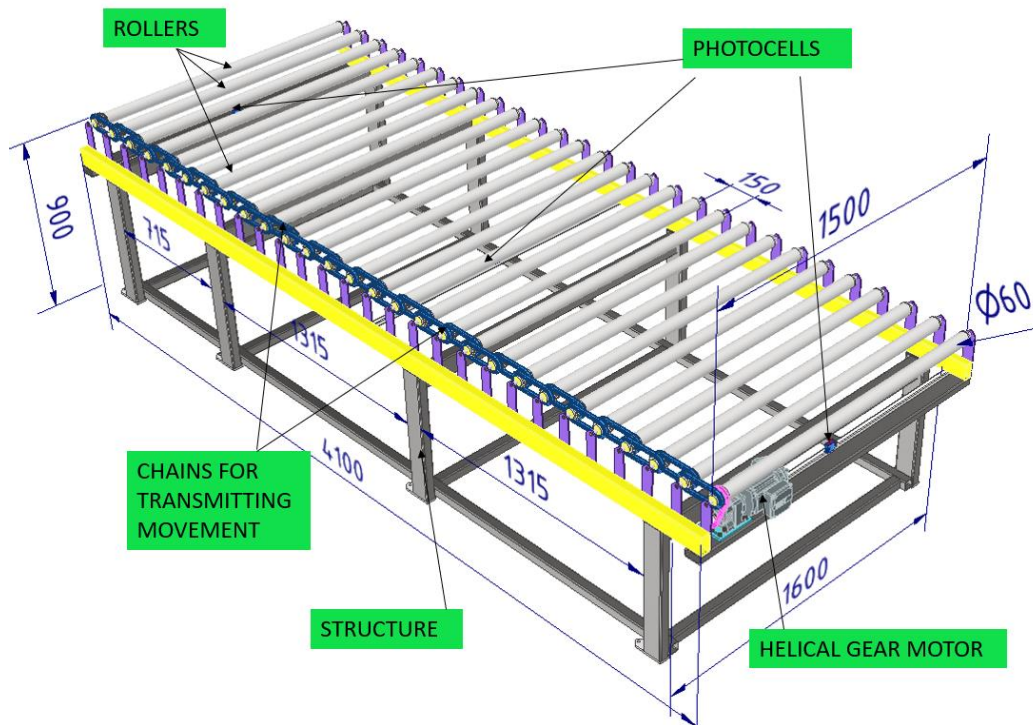

Figure 10.1. Roller conveyor before grinding machine in Autodesk Inventor.

### 10.1. ROLLERS

The roller selected is from the company Interroll. The material to move is the sets of 14 wooden sheets. So I will do some calculations:

I have 14 pieces  $\times 8 \times 10^{-3} \text{ m}^3$  each piece  $\times 800 \text{ kg/m}^3 = 89,6 \text{ kg}$ .

That makes a strength of  $89,6 \text{ kg} \times 9,81 \text{ kg} \cdot \text{m/s}^2 = 878,98 \text{ N}$ .

According to these calculations, I can take the roller called heavy-duty conveyor roller series 3560. The characteristics of this roller are:

- It is a stable, fixed drive conveyor roller, with welded steel sprockets and a steel tube of 60 x 3 mm.



- It is reinforced by a captive shaft. It includes a 17 mm diameter female treaded shaft.
- Small pitches are possible, with a diameter of 60 mm and tangential drive.
- Gentle lateral pushing of the materials to be conveyed, as the tube ends in a rounded shape.
- Sealed precision ball bearing.
- Zink-plated is a component after welding.

The technical data can be seen in the Chart 10.1.

<b>General technical data</b>	
Max. load capacity	3,000 N
Max. conveyor speed	1.2 m/s
Temperature range	-5 to +40 °C
<b>Materials</b>	
Bearing housing	Polyamide
Drive head	Steel
Seal	Polyamide
Ball bearing	Steel 6003 2RZ

*Chart 10.1. Technical data of the heavy-duty conveyor roller series 3560 of Interroll.*

The specific parameters chosen are:

- Drive Type: Sprocket Steel 5/8" T13 double.
- Shaft type: Female Thread.
- Extension: 30 mm
- Female Thread: M10
- Sleeve: None
- EL: 1500 mm
- Two steel sprockets.
- Detailed Drive Head (for the CAD drawing): true

With those dimensions, the force each of the rollers can stand is shown in the next Chart 10.2.

**Female threaded shaft version**

Tube material	Ø Tube mm	Ø Shaft mm	Max. load capacity in N with an installation length of mm					
			200	900	1,000	1,100	1,300	1,500
Steel, zinc-plated	60 x 3	17	3,000	3,000	2,910	2,160	1,290	830

Chart 10.2. Maximum load capacity of the heavy-duty conveyor roller series 3560 depending on the length.

The maximum load on each roller is 830 N. As the load is 878,98 N, I can put the rollers at a distance of 150 mm, so each time as minimum the wood sheets are in three rollers at the same time, what makes it work perfectly. The dimensions of this roller are the ones indicated in Figure 10.2.

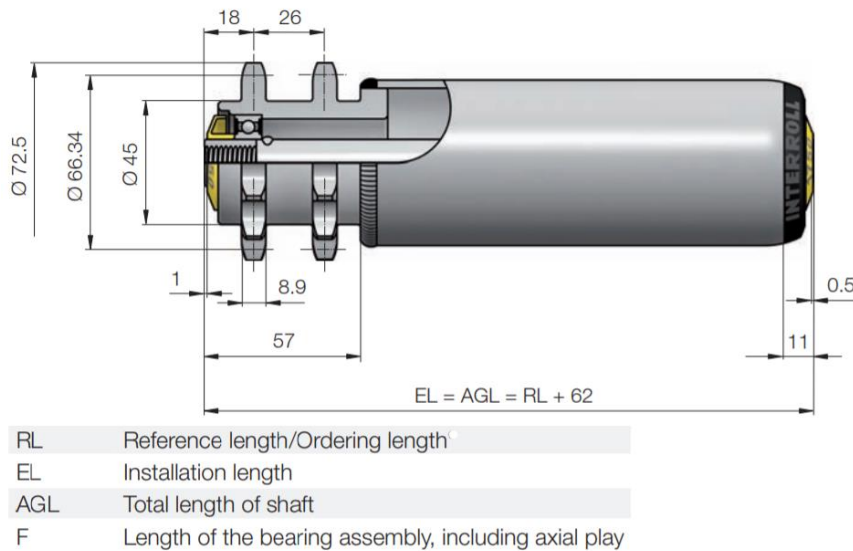

Figure 10.2. Dimensional drawing of the heavy-duty conveyor roller series 3560 in mm.

The drawing obtained in Autodesk Inventor is illustrated in the Figure 10.3.

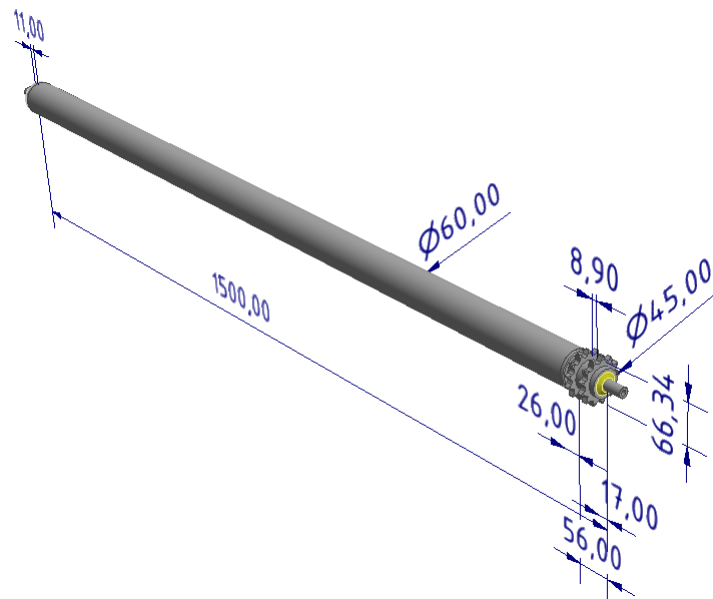

Figure 20.3. 3D image of the heavy-duty conveyor roller series 3560 in Autodesk Inventor with dimensions in mm.

For more information the datasheet of the heavy-duty conveyor roller series 3560 is in the annex 2.

## 10.2. MOTOR

For the motor I will do some calculations for knowing the revolutions per minute, if the speed I want for the roller conveyor is 20 m/min, and the diameter of the roller chosen is 60 mm:

$$RPM_{motor\ 1} = \frac{1000\ mm/m \times 20\ m/min}{\pi \times 60\ mm} = 106,10\ [1/min]$$

The motor chosen for this application is from the company SEW EURODRIVE. Among all this motors, considering that the length of the roller conveyor is 1500 mm and that each roller has a separation of 150 mm, what makes a total of 28 rollers, and the load shared in three of them is maximum 878,98 N, the motor chosen is the R..DR series gearmotor. That consists on an R series helical gear units with three-phase motor AC motor-DRN.

Helical gears provide a torque from 50 Nm to 18000 Nm. The R series meet the high requirements in terms of the output rotational speed and low weight. They offer high efficiency, and the ratio of torque is optical according to the space required. It has a foot-mounted design, output shaft with key. This unit are lubricated for life, so they do not need a scheduled oil change. The structure of this units is illustrated in Figure 10.4.

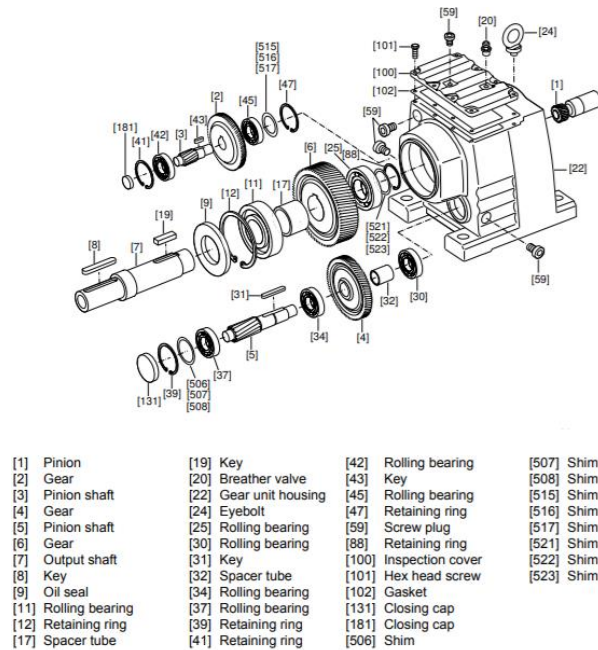

Figure 10.4. Basic structure of helical gear units R of the company SEW.

The R..DR series gearmotors demonstrate unrivalled properties in the field of energy efficiency.

A perspective view, as well as frontal and side views of this motor can be seen in Figure 10.5.

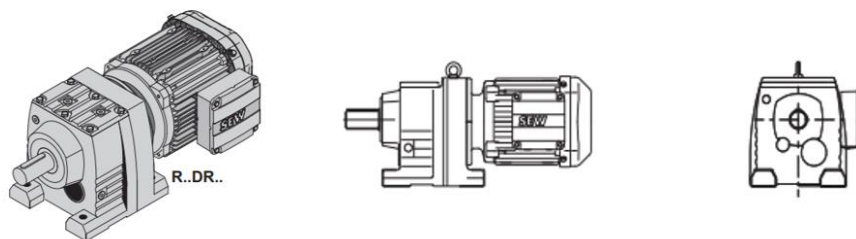

Figure 10.5. Perspective, frontal and side views of the R..DR.. helical gearmotor in foot-mounted design.

The type of motor chosen according to the necessities required: the speed of the line around 20 m/min and a power of 0.75 kW because only one motor will be used for the machine that is 4100 mm long, is R17DRN80M4. The product data is shown in the following Chart 10.3.

Rated motor speed	[1/min] : 1440
Output speed	[1/min] : 111
Overall gear ratio	: 12,98
Output torque	[Nm] : 65
Service factor SEW-FB	: 1,30
Mounting position	: M1
Base / top coat	: 7031 Blue gray (51370310)
Position of connector/terminal box	[°] : 0
Cable entry/connector position	: X
Output shaft	[mm] : 20x40
Permitted output overhung load with n=1400	[N] : 1360
Lubricant quantity 1st gear unit	[Liter] : 0,25
Motor power	[kW] : 0,75
Duration factor	: S1-100%
Efficiency class	: IE3
Efficiency (50/75/100% Pn)	[%] : 80,7 / 82,9 / 82,9
CE mark	: Yes
Motor voltage	[V] : 230/400
Wiring diagram	: R13
Frequency	[Hz] : 50
Rated current	[A] : 3,05 / 1,75
Cos Phi	: 0,74
Thermal class	: 130(B)
Motor protection type	: IP54
Design requirement	: Europe (CE)
Motor mass moment of inertia	[10 <sup>-4</sup> kgm <sup>2</sup> ] : 25,00
Weight	[kg] : 17,00

*Chart 10.3. Technical data of the SEW helical gearmotor R17DRN80M4.*

Checking the above chart, the motor chosen has the value of output speed of 111 1/min. The required one was 106.10 1/min, so it is acceptable. The speed of the material in the roller conveyor is going to be:

$$V_c = \frac{\pi \times 60 \text{ mm} \times 111 \text{ 1/min}}{1000 \text{ mm/m}} = 20.92 \text{ [m/min]}$$

A lot of information can be known with that chart, among others, is:

- The output torque is 65 Nm.
- The frequency is 50 Hz.
- The motor power, as required, is 0.75 kW.
- It has the CE mark.
- The efficiency class is IE3, an international efficiency standard.

For more technical information it is possible to check the documentation in the annex 2.

When downloading the motor for placing it in Autodesk Inventor, the image shown in Figure 10.5 appears.

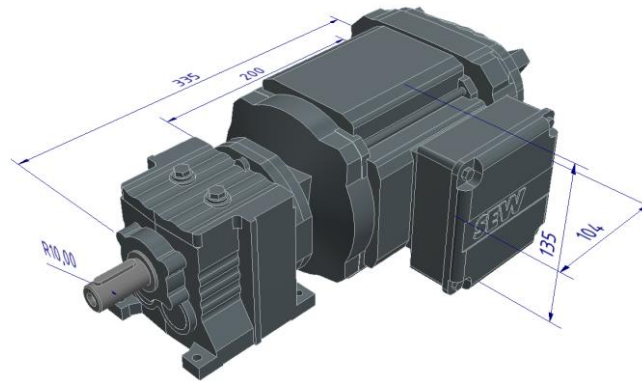

Figure 10.5. Image of the helical gear motor R17DRN80M4 in Autodesk Inventor with dimensions in mm.

### 10.3. STRUCTURE OF THE ROLLER CONVEYOR

The roller conveyor structure is 4100 mm long, on which 28 rollers are distributed. These 60 mm diameter rollers have a distance between their axes of 150 mm. The rollers move thanks to the presence of chains that connect them two by two. That is, each roller has two sprockets. Each of them connects with the sprocket of the roller on its right or left side. This goes on until you reach the first roller, where one of the sprockets connects with a sprocket on the motor. It is the motor that transmits the entire movement to the entire conveyor. The chains have been created with the Design Accelerator, following the steps explained in section 7.7.1. *Creation of the chains and sprockets*. This mechanism can be seen closely in Figure 10.6.

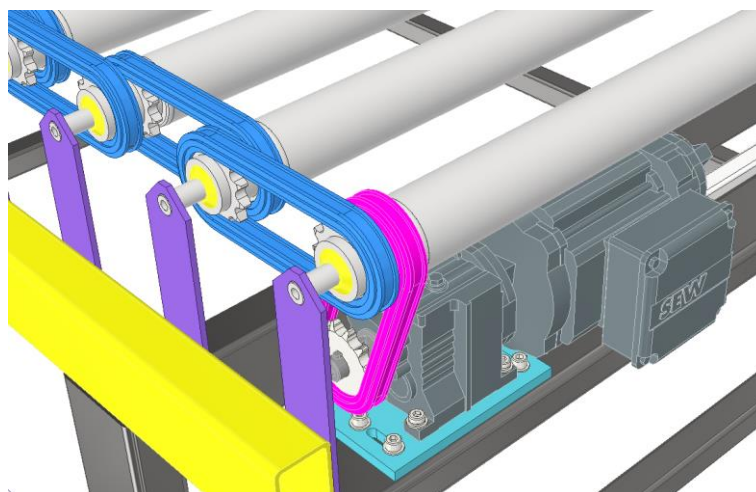

Figure 10.6. Chains that connect the rollers between them and with the motor in the roller conveyor.

In the Figure 10.6 above it can be seen that the motor is fixed with a plane which dimensions fit with the holes of the motor and also have space for fixing the motor to the main structure of the roller conveyor. The plane is joined with PN-87/M-82302 M8 x 20 mm bolts, and between them and the plane there are PN-78/M-82005 0,4 mm plain washers. This plane can be seen closer in Figure 10.7.

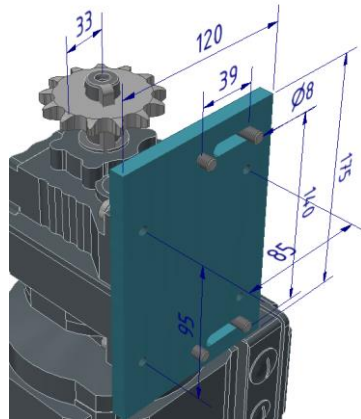

Figure 10.7. Plane that fixes the motor to the main structure in the roller conveyor with dimensions in mm.

This motor is supported on a rectangular tube DIN EN 10210-2 80 x 40 x 5 mm and length 1600 mm. There are two such beams, each of them in the edges of the machine, which connect the yellow rectangular side tubes DIN EN 10210-2 90 x 50 x 4 mm and length 4100 mm. Above them, purple rectangular-shaped structures with sloping sides support each of the 28 rollers present in the machine. Their dimensions can be seen in Figure 10.8.

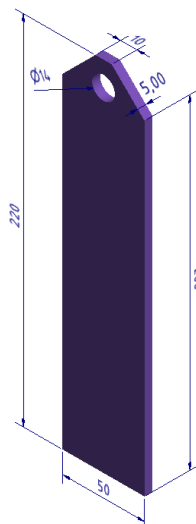

Figure 10.8. Piece that holds the roller by each side in the roller conveyor.

Under the yellow rectangular tubes are four vertical rectangular tubes on each side, also DIN EN 10210-2 but with dimensions 100 x 50 x 5 mm. They are not evenly spaced, but there are two gaps between these larger legs so that the 300 mm high chain conveyor that transports the pallets can pass underneath without any difficulty. This is because the distance of a pallet from side to side is 1000 mm, a little wider than the three chains that transport it, and the gap left in this machine is 1315 mm, so that if there is any slight deviation of the pallets, this is not a problem. These legs are also connected with a longitudinal square tube DIN EN 10210-2 50 x 50 x 4 mm and length 4100 mm. Another four transversal square tubes of the same standard and length 1400 mm connect those tubes from side to side, four in the upper side and other four closer to the floor. Finally, there are eight pieces with a whole that lay on the floor and where a bolt can be put to fix the structure to the floor. These pieces are shown in Figure 10.9.

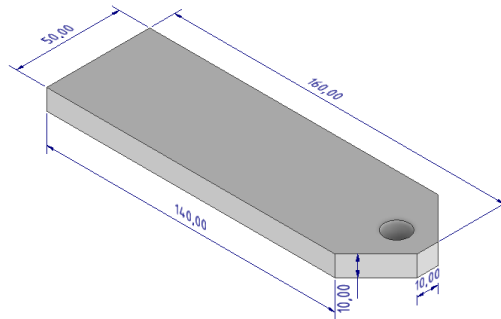

Figure 10.9. Parts resting on the floor on roller conveyors with dimensions in mm.

## 10.4. SENSORS

Three optical sensors are displayed on the roller. On in the beginning, on the right side, that will inform in order of any problem happening, because the pieces should never reach that side. Other sensor is located in the middle of the roller conveyor, and finally one in the end, just before the entrance to the grinding machine. With these three sensors it is possible to control and know where the material in every moment is. The sensors chosen are the same as in the chain conveyor, photocells from the company SICK, type WL12-3V2431, with article number 1041537. Those sensors are explained previously in the section 7.4.1. *Election of the sensors.*

The sensors are located in the middle of the rollers, between to of them always, and having the wider side aligned to the rollers, so it can detect the wood even if the gap of 5 mm between wooden sheets is on the top, what is unlikely as the robot locates the wood so the sensor can clearly detect it. They are fixed with a square tube from the Content Centre DIN EN 10210-2 with dimensions 25 x 25 x 3 mm, length 1600 mm, and it is fixed in the yellow rectangular tubes from the part of below, so it does not get closer to the motor. As the sensor has a long detection range, the distance is not a problem. An image of this structure can be seen in Figure 10.10.



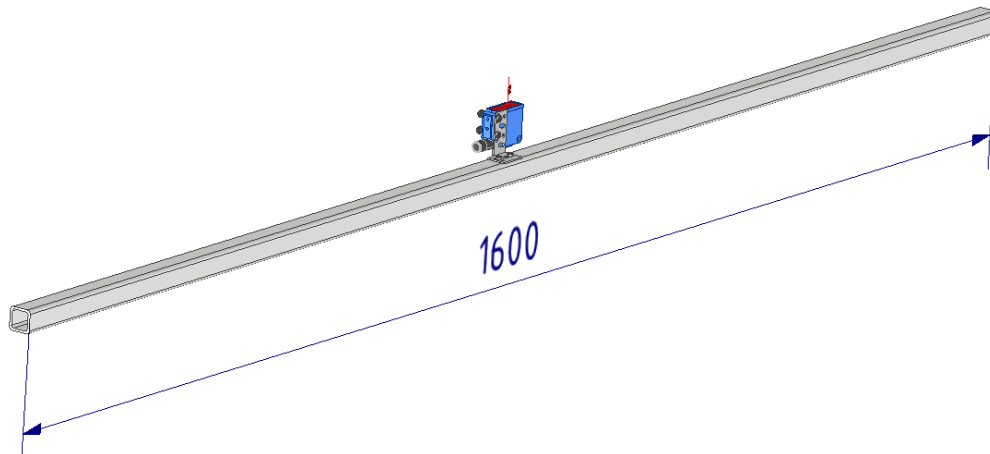

Figure 10.10. WL12-3V2431 photocell from SICK on a square tube with the length in mm.

## 10.5. ROLLER CONVEYOR IN THE LINE

The roller conveyor receives the wood pallets from the vacuum gripper that the robot moves and it takes them to the grinding machine at a speed of 20,92 m/min according to the motor used. Under it, the chain conveyor transport pallets. An image of the roller conveyor in the line can be seen in Figure 10.11.

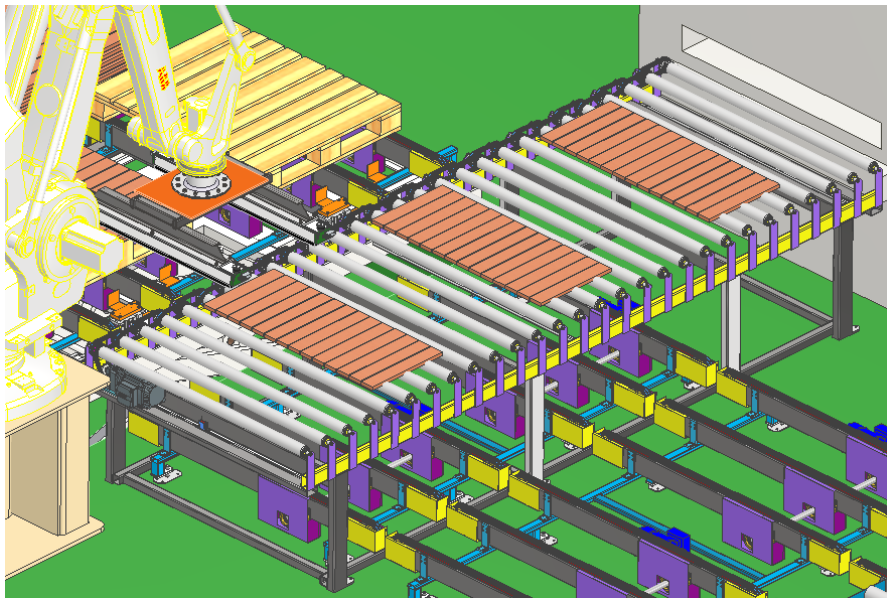

Figure 10.11. Roller conveyor on the line transporting wood sheets in groups of 14 elements.

## 11. CALIBRATING SANDING MACHINE

The main objective of this automatized line is grinding the wooden sheets that enter in the grinding machine. Due to this aim, the choice of this machine is essential.

The fourteen wooden sheets separated by a distance of 5 mm between one and other, occupy a length of 1185 mm. That means a machine with a little bit wider space is required.

The machine chosen is the top calibrating sanding machines series K of the company Costa Levigatrici. The working width chosen is 1350 mm, perfect for my process. The height of the machine is 900 mm, so the previous and next rollers must have the same height. An image of this machine can be seen in Figure 11.1.



Figure 11.1. Calibrating sanding machine series K, company Costa Levigatrici.

The high-speed top calibrating sanding machine, with full sound protections to 75 dB, air return system, automatic re-setting control to hold thickness tolerance on work pieces with laser probes reading.

The calibrating machines are utilized for the accurate preparation of layers, and in a stand alone or in first position of the finishing line to dimensions the thickness of the planks. The reasons why calibrating the individual layers are the following:

- To have better utilization of the press, with even more pressure on the work pieces.
- To have a more stable plank with layers that have normalized thickness.

- To avoid taking the exceeding thickness tolerance of the internal layers from the top layer.

After pressing, the wooden sheets should be calibrated-sanded. On the top side the surface finish requirement is determining the number of working units, up to 6 units on top side, depending on feed speed and take away needed. In this case, 3 units on top side are chosen. The power of the working units is in relation to the amount of take-away, to the sanding belt grit utilized, to the feed speed of the line. In Figure 11.2, an image of the inside of this machine can be seen.



*Figure 11.2. Inside view of the Series K calibrating sanding machine of the company Costa Levigatrici.*

The filler sanding machine is utilized in the wood sheets working cycle, as this is the case, to level the filler applied to close the gaps between the top strips of the surface. This machine is equipped with one cylinder and two pad units. This is shown in Figure 11.3.

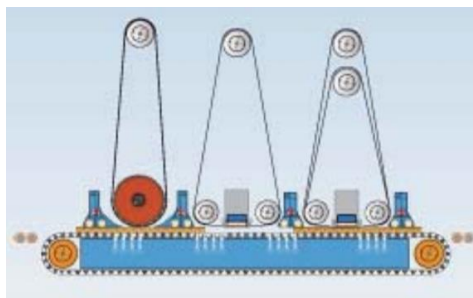

*Figure 11.3. Scheme on how the Costa Levigatrici Series K calibrating sanding machine works.*

Top calibrating-sanding machines have the following characteristics:

- Constant pass-line.
- Abrasive belt length 2620/3250 mm.
- Thickness adjustment from 0 to 160 mm.

The series K calibrating grinding machine has some special features: Feed and drive system. It is included due to s a uniform feed speed is needed in order to obtain a constant take away and a fine surface finish, without thickness variations or chatter-marks. The drive systems of this machine is constituted by:

- The feed table.
- Traction rollers rubber covered of diameter of 200 mm.
- The rubber feed belt. First class belts with close loop with 2, 3 or 4 layers in the internal structure, with a thick layer of rubber with the objective of unable several re-grinding operations are utilized.
- An automatic centring system, with double switches, as it can be seen in Figure 11.4.



Figure 11.4. Automatic centring system of the wood sheets in the Series K calibrating sanding machine by Costa Levigatrici.

- The feed drive unit. An automatic feed speed control system in relation of power utilization is included in this machine. This system assures the most appropriate machine utilization. An electronic system is monitoring in real time the power utilization of the calibrating motors. An scheme of how does it work is shown in Figure 11.5.

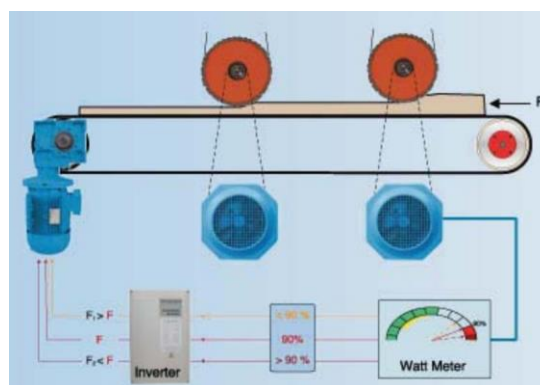

Figure 11.5. Scheme of how the automatic feed speed control system works in a Series K calibrating sanding machine of Costa Levigatrici.

PLC Vision system is used for the calibrating machines control system. The PLC panel vision is a very useful tool that enables the worker to visualize in an touch-screen monitor the actual setup data and operation of the machine, and to store many working programmes. The user can program only thickness and feed speed adjustment. There are various pages available for a lot of machine functions. Each function can be stored and form a complete working programmes that are easy to store and recall with codes. An illustration of what can be seen in the screen is shown in Figure 11.6.



Figure 11.6. Example of what can be seen in the screen of the PLC in the Costa Levigatrici Series 6 calibrating sanding machines.

SSE or Selective air jet blowers with electronic control of the position, dimensions and timing of activation of the single nozzles are placed in the areas of utilization of the sanding belts. The position of this air jet blowers is by the tension roller. The reason why is that is far more efficient to clean the dust clogged in the sanding belts when the belt-grit is open. The dust stuck in the belt is blown towards the top dust-hood of the working unit. A drawing of this system can be seen in Figure 11.7.

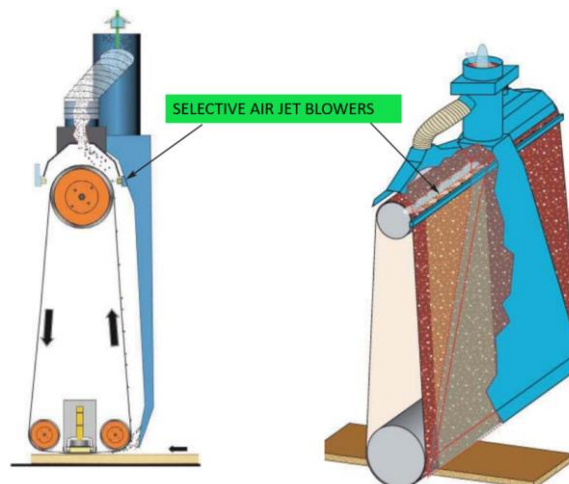

Figure 11.7. Drawing of selective air jet blowers in Costa Levigatrici machines.

Dust hood valves with electronic control for saving air requirement. The entrance of the central dust system should be from the front side. This has an explanation: the largest amount of dust is taken by the from working units. Moreover, wide radius curves have

to be places to connect the machine to the central pipe in order to keep the air speed high. Additionally, an air speed of 3 or 4 m/s higher than the cutting speed of the sanding belts is recommended to ensure the easy flood of the dust particles into the dust hoods. Furthermore, an automatic valve for dust extraction control SCA es planes. This pneumatical operated gates area placed on the top of each manifold, in the area of the connection to the main dust system. An electronic control of the In-feed Sensing Bar controls the opening and closing of the valves depending on the presence of work-pieces inside the machine. The next picture illustrates how to correctly install the centralized dust connectors, in Figure 11.8.

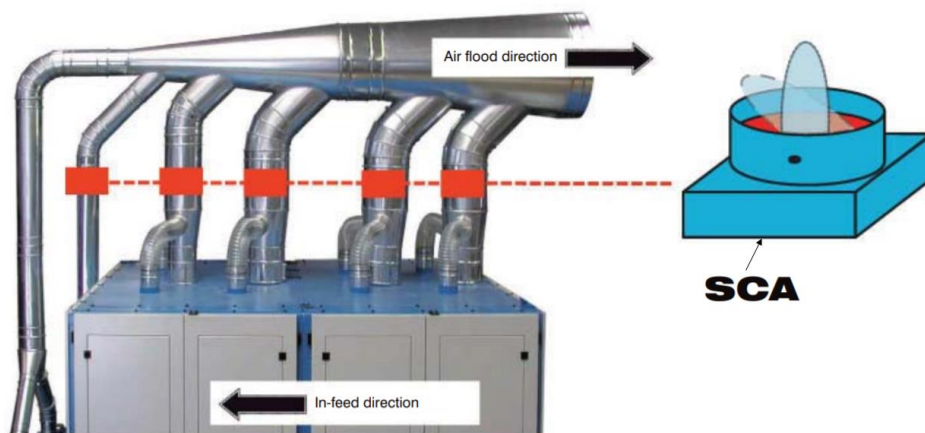

Figure 11.8. Efficient centralized dust connector in Costa Levigatrici calibrating-sanding machines.

Automatic control of thickness tolerances with the laser unit TRL-3, that assures an accurate reading system of measuring thickness. This retro-action control implies a set of laser probes that keep reading the processed panel thickness and is eventually automatically resetting the machine height to the required thickness. The thickness read-out system includes a monitor for the digital reading of the values obtained. A PLC is included for coordinating the automatic system of resetting, following these steps:

- Firstly, reads the panel thickness for a predetermined length of space or time,
- Then, it compares the thickness of the value set in the machine and the one of the panel.
- Finally, it makes the decision of setting the thickness in the machine at the necessary height, that for our machine is 4.6 mm (the wooden panels enter with a width of 5 mm and the less possible quantity of oak wood must be removed, so 0.4 mm removed are enough).

In Figure 11.9 an image of how this process of the PLC explains it.



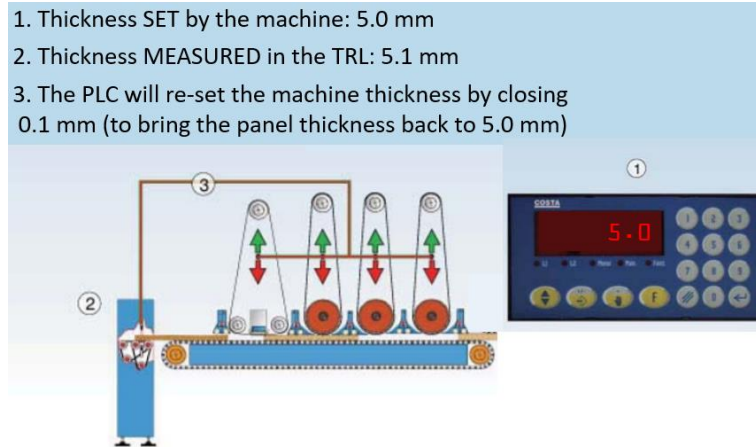

Figure 11.9. Explanation how the PLC height control process works in the Costa Levigatrici Series 6 calibrating sanding machine.

For more information about the Costa Levigatrici Series 6 calibrating sanding machine, the details can be checked in the document included in annex 2.

There is not available CAD drawing for this machine, so in the line built in Autodesk Inventor I am placing a white box with the dimensions of the sanding machine to represent it, as I do not have to build the machine because it is bought on the company Costa Levigatrici, as I have just explained.

## 12. ROLLER AND BELT CONVEYOR AFTER SANDING MACHINE

The roller belt conveyors are situated after the calibrating sanding machine. There are two equal machines, one after another, that have the following structure: the first part is a still roller conveyor, and the second part is an up and down moving roller conveyor with a still belt conveyor. Both parts are joined with a bigger structure that connects them. The function of each part is the following:

- First still roller conveyor, take the pieces out of the sanding machine.
- Second, moving roller conveyor and two chain conveyors, which function is changing the direction of the 14 wooden sheets each.
- Thirdly, another still roller conveyor. It is there in order to separate two flows belt conveyor from the other two. The reason of the separation is for leaving space in order to later locate the robot in the middle of both belt conveyors. Consequently, it would be able to operate with the wooden sheets without the necessity of another lifting table in the line.



- Finally, the other moving roller conveyor combined with the double belt conveyor, to change the direction of another two wood sets of fourteen wooden sheets each.

To summarize, each machine has two fundamental parts: the roller conveyors and the chain conveyors. Both machines will be explained separately for a better understanding, as well as the structure that joins them both,

An image of one roller conveyor combined with a double chain conveyor with its dimensions is shown in Figure 12.1.

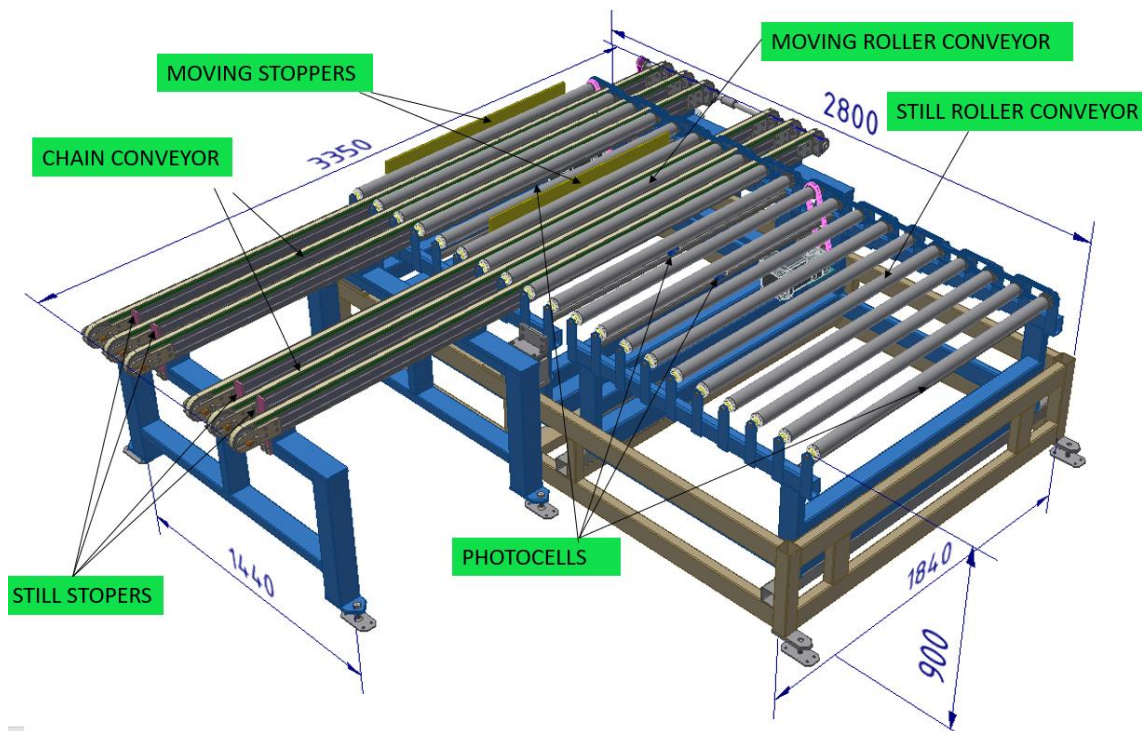

Figure 12.1. Belt roller conveyor with dimensions in mm.

## 12.1. ROLLER CONVEYOR

The first roller conveyor out of the calibrating and sanding machine should have a speed of 30 m/min because the area after this machine should be free as soon as possible.

The rollers chosen are the same as in the other roller conveyor before the sanding machine. From the company Interroll, the heavy-duty conveyor roller series 3560. The distance between their axes is 140 mm. In each roller conveyor, the still and the moving one, there are 10 rollers in total. Each roller is held by the same piece as in the previous roller conveyor. Those parts are welded to an 80 x 50 x 4 mm rectangular tube of 1300 mm of length. The rollers are connected two by two with chains, and then to

the motor with another chain, in order to transmit the movement from the motor to the ten rollers. A closer view of this mechanism can be seen in the Figure 12.2.

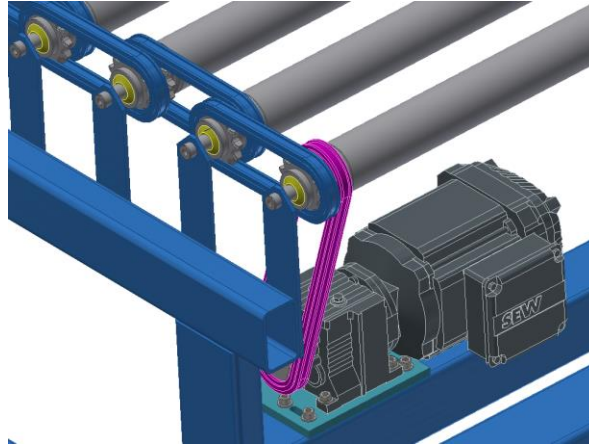

Figure 12.2. Close view of the way of transmitting the movement from the motor to the rollers with chains.

The motor chosen is of the same company as the other roller conveyor, SEW EURODRIVE. Considering that the length of the roller conveyor is 1500 mm and that each roller has a separation of 140 mm, what makes a total of 10 rollers, and the load shared in three of them is maximum 878,98 N, the motor chosen is the R..DR series gearmotor. That consists of an R series helical gear units with three-phase motor AC motor-DRN. As the number of rollers changes, and also the speed, new calculations need to be made:

$$RPM_{motor\ 4} = \frac{1000\ mm/m \times 30\ m/min}{\pi \times 60\ mm} = 159.16\ [1/min]$$

Moreover, as the number of rollers is smaller, motors of 0.55 kW can be used. The RPM used are going to be 159 1/min. In conclusion, the type of motor is the same as in the roller conveyor before the sanding machine, R07DRN80M4, helical gear units R + AC motor DRN (IE3), but some parameters have changed in comparison with the ones of the Chart 10.3 associated with the previous motor used:

- Rated motor speed: 1435 1/min.
- Output speed: 159 1/min.
- Overall gear ratio: 9.01.
- Output torque: 33 Nm.
- Service factor SEW-FB: 1.50.
- Permitted output overhung load: 800 N.
- Lubricant quantity 1<sup>st</sup> gear unit: 0.12 litres.
- Motor power: 0.55 kW.

- Efficiency: 78.55/81/80.8 %
- Rated current: 2.25/1.29 A.
- Cos Phi: 0.75.
- Motor mass moment of inertia:  $17 \cdot 10^{-4} \text{ kg} \cdot \text{m}^2$ .
- Weight: 13 kg.

To get more information about this motor, the datasheet is available in the annex 2.

All the structural shapes, rectangular or square, follow the standard DIN EN-10210-2. The rollers are supported by planes that rest in  $80 \times 50 \times 4 \text{ mm}$ ,  $1310 \text{ mm}$  length rectangular tubes. The motor is located on one perpendicular tube, parallel to the rollers, with dimensions  $80 \times 80 \times 4 \text{ mm}$  and length  $1500 \text{ mm}$ . There are two of those in the beginning and end of the structure. Moreover, four vertical legs with dimensions  $100 \times 40 \times 3 \text{ mm}$  and length  $330 \text{ mm}$  elevate the structure up. These legs are connected with four tubes, parallel to the floor, forming a rectangle: parallel to the rollers are  $100 \times 100 \times 4 \text{ mm}$  and  $1500 \text{ mm}$  long tubes, and the perpendiculars are  $100 \times 40 \times 3 \text{ mm}$  and  $1200 \text{ mm}$  long shapes.

For an illustrative explanation, one image of this roller conveyor can be appreciated in the Figure 12.3.

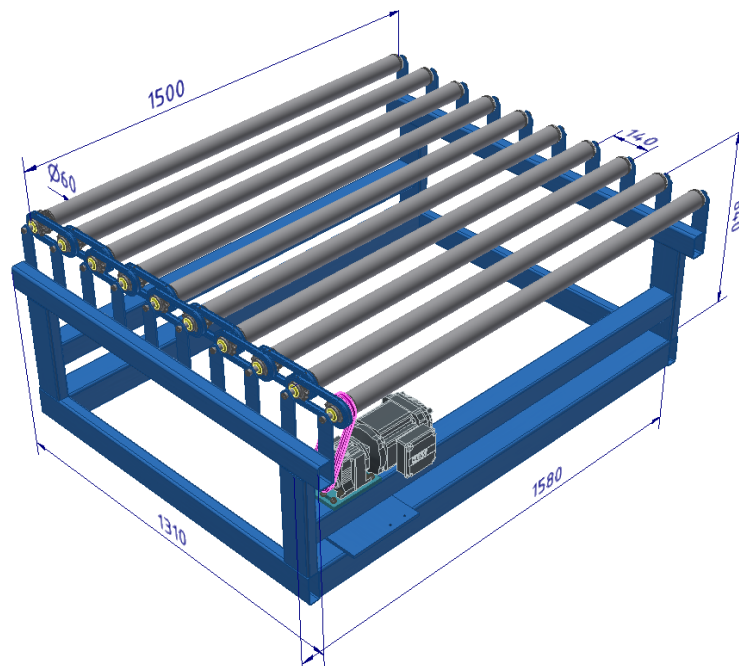

Figure 12.3. Roller conveyor after sanding machine with dimensions in mm.

## 12.2. STRUCTURE TO SUPPORT TWO ROLLER CONVEYORS

### 12.2.1. MAIN STRUCTURE.

There is one structure which aim is to hold both roller conveyors, one still and the other one with a moving mechanism. In this structure all the tubes are following the standard DIN EN 10210-2. The main structure is constituted by two 100 x 50 x 3 mm, 2650 mm long rectangular structural shapes on each longer side, and 1700 mm the ones on the smaller side. They are separated by rectangular tubes of 50 x 50 x 4 mm and length of 210 mm. There are four legs in the corners 70 x 70 x 4 mm, of height 410 mm. There are to rectangular shapes PN-86\_H-93403 – C 100 x 50 mm in the middle of the structure to enforce it, which length is 1700 mm. Moreover, the pieces that rest in the floor are the same ones as in the other roller conveyor, with holes for fixing them to the floor. On top of the higher and longer tubes there are four planes, dimensions 275 x 70 x 10 mm, that are going to be used to support four cylinders that I will explain in the next section 12.2.2. *CYLINDERS*. An image of the structure can be appreciated in Figure 12.4.

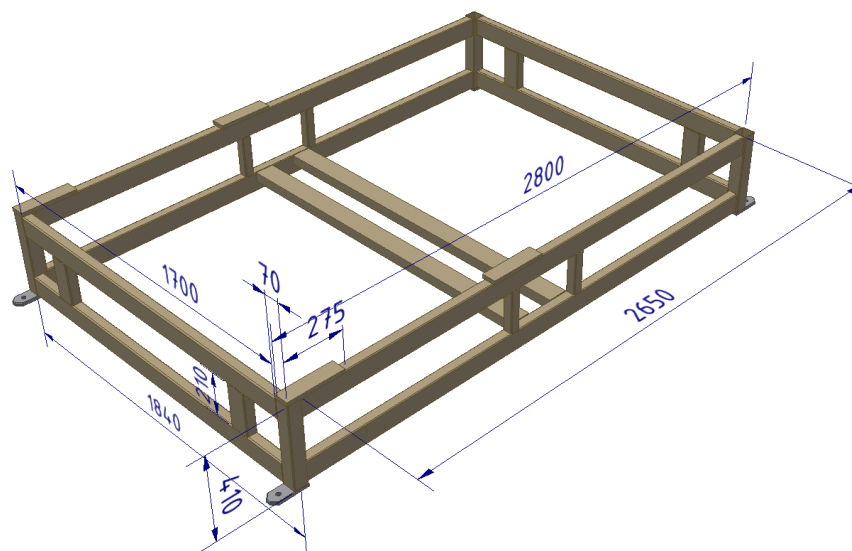

Figure 12.4. Structure that holds the two roller conveyors.

As it has been said before, the first roller when going out of the sanding machine must be still. For that, two tubes of dimensions 70 x 70 x 4 mm and length 1840 mm has been placed between the two down longer tubes.

For the second roller, cylinders are necessary to move the roller conveyor up and down in order to change the wood elements from the roller conveyor to the chain conveyor. The choice of this cylinders as been made according some parameters.

### 12.2.2. CYLINDERS

For the up and down movement of the moving roller conveyor, the cylinders that have been chosen are type MGPM80TF-30Z-M9B, from the company SMC. This type of cylinder has been explained in section 8.3.1. *PNEUMATIC CYLINDERS*, due to one of this type was used to lift the stoppers in the lifting table. The weight that must be lifted in one and other is obviously different, so the bore side of this one, that must lift the whole structure plus the wooden elements on it, must have a diameter of 80 mm. That changes some parameters if compared with the same cylinder used before of 20 mm diameter. The main changes are:

- Bore size: 80 mm diameter.
- Theoretical cylinder force, advanced stroke (at 0.5 MPa): 2513 N, instead of the 157 N of the other cylinder.
- Theoretical cylinder force, return stroke (at 0.5 MPa): 2323 N, instead of the 118 N of the other cylinder.
- Maximum piston speed: 400 mm/s, different than the other cylinder that it is 500 mm/s.
- Non-rotational accuracy of plate:  $\pm 0.03^\circ$ , whereas the previous one was  $\pm 0.06^\circ$ .

This cylinder has different shape, as it can be seen in the planes in Figure 12.5.

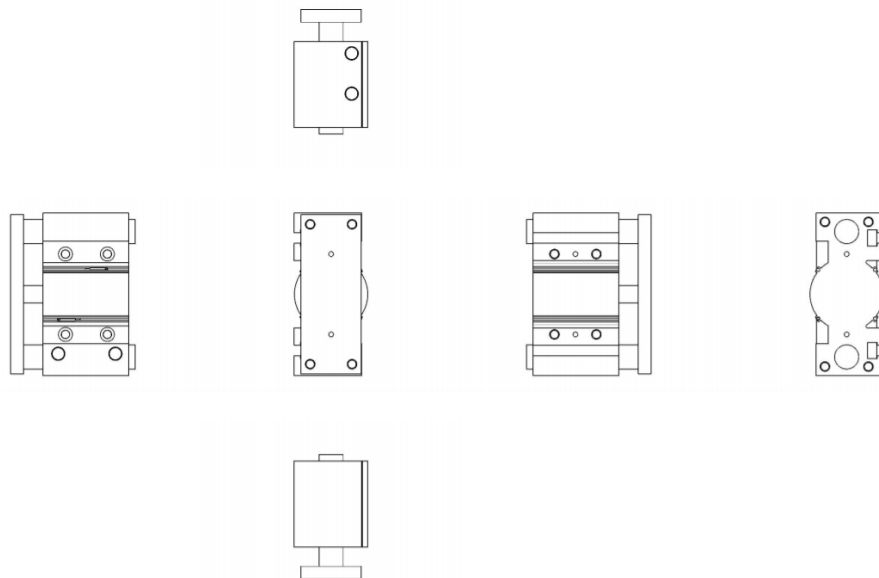

*Figure 12.5. Views of the MGPM80TF-30Z-M9B cylinder with the bore side of 80 mm.*

On the next image there is the CAD drawing of this cylinder, one is the picture that can be seen, and the other is half view to appreciate the dimensions in general and, particularly, of the bore size (Figure 12.6).

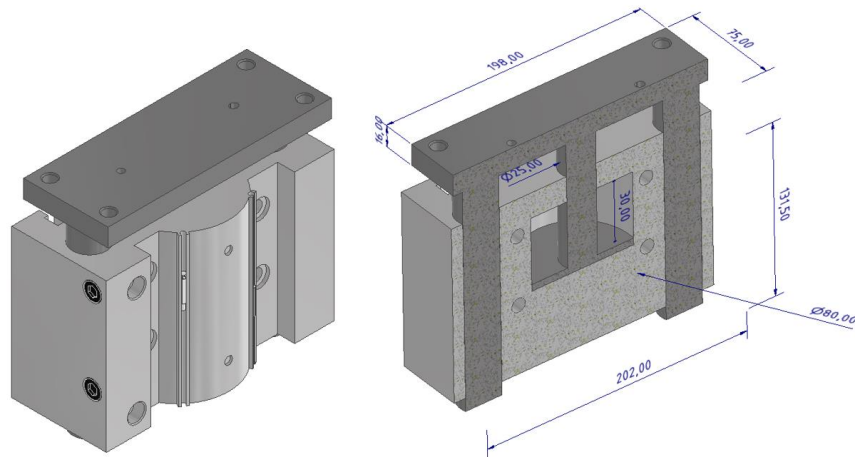

Figure 12.6. Image of the MGPM80TF-30Z-M9B cylinder with the bore side of 80 mm, on the left the full view of the cylinder, on the right, half view of it with dimensions in mm.

For more information about this cylinder, the datasheet is available in the annex 2 of this project.

There are four cylinders like this, located on the structure explained in the previous section 12.2.1 *Main structure*, on the planes situated there with this aim. The cylinders are fixed from the lower side to this plane with two DIN 6912 M10 x 20 mm bolts on one of the sides. On top of the cylinder there is a L shaped plane with dimensions 198 x 75 mm and with holes for the bolts of the same type separated 174 and 52 mm, as the ones in the cylinder, so they can fix perfectly. Another plane is located on the other side of that structure, joined with the same bolts. This side is the one that holds and connects to the structure of the roller conveyors. The pieces I have just described can be seen together, from two opposite sides and with dimensions in Figure 12.7.

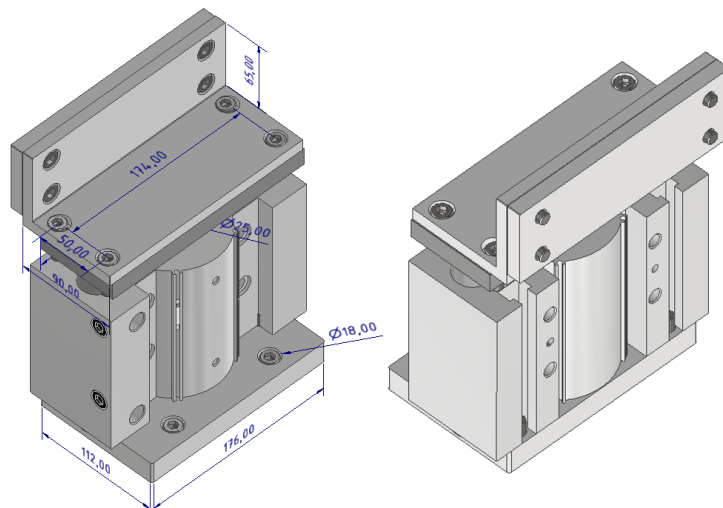
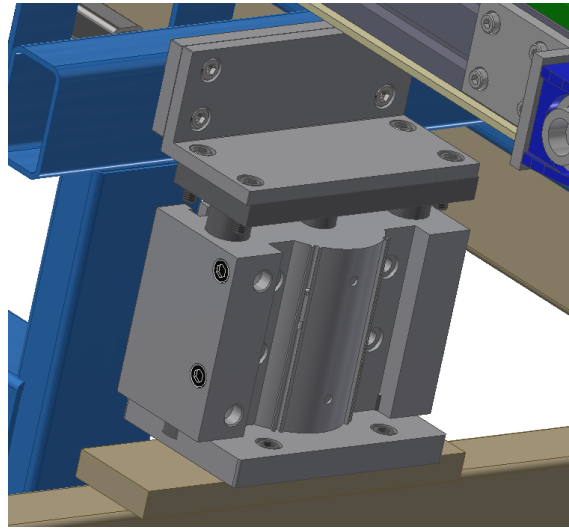

Figure 12.7. Structure that connects the cylinders with the main structure that rests in the floor and with the chain conveyor. Dimensions in mm.



A close view of one of these cylinders located in the main structure can be seen in Figure 12.8.



*Figure 12.8. Close view of one of the four cylinders that lift the moving roller conveyor.*

## 12.3. BELT CONVEYOR

The belt conveyor is used to transport the wooden elements in other direction so the robot can take them all. It is form by two different groups of three belts, each of one takes 14 wooden elements at the same time.

The height of these conveyors is 885 mm. Therefore, the roller conveyor must be lowered with the help of the cylinders to a height of 870 mm, as it must be positioned below this belt conveyor.

### 12.3.1. BELT ARMS

The arms of this belt conveyor have a length of 3265 mm from axle to axle. The pulleys on which the belt conveyor rotates have been obtained with the Design Accelerator function. In the toolbar Design → Design Synchronous Belt section, a window called Synchronous Belt Component Generator, like the one shown in Figure 12.9, opens.



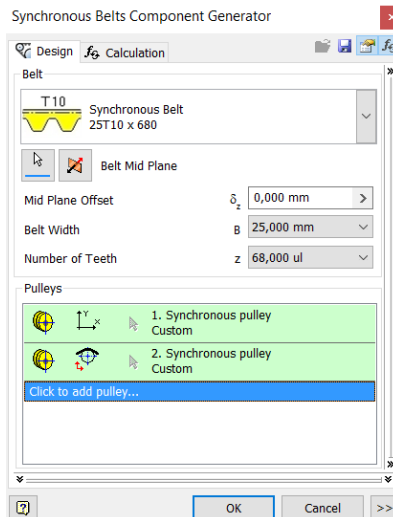

Figure 12.9. Window of Synchronous Belts Component Generator in Autodesk Inventor.

There, it is possible to choose the type of belt. The one chosen has been Synchronous belt 16T10 x 720. The belt width is 25 mm. The length will be chosen later, because it is the same as when creating the sprockets for the chains: the distance cannot be chosen now, but only the wheels on which the belt slides with its characteristics, because I cannot know how many teeth correspond to the length I desire. Afterwards, these wheels are placed the desired distance apart, in this case 3265 mm, and then the process is repeated with the Synchronous Belt Design Accelerator, selecting the existing pulleys.

The pulleys have been custom chosen: I want them to be 30 mm thick, to give the belt some slack, and with 31 teeth. All features can be seen in the window in Figure 12.10.

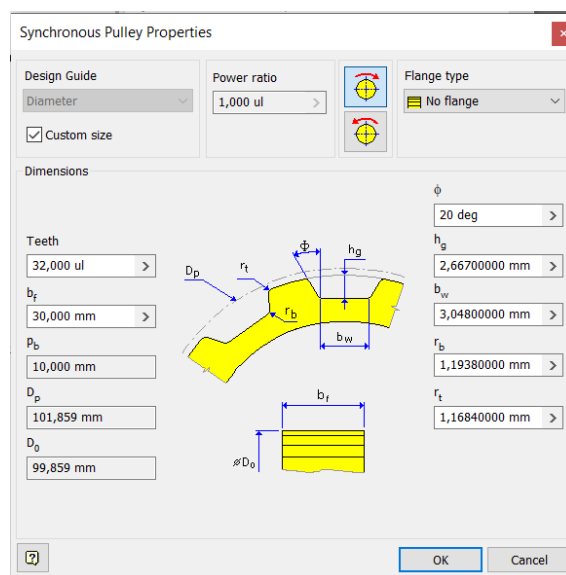

Figure 12.10. Window for choosing the parameters of the pulleys.

Once this pulley is created, it must comply with the shape and dimensions available on the market. The required shape is shown in Figure 12.11 below.

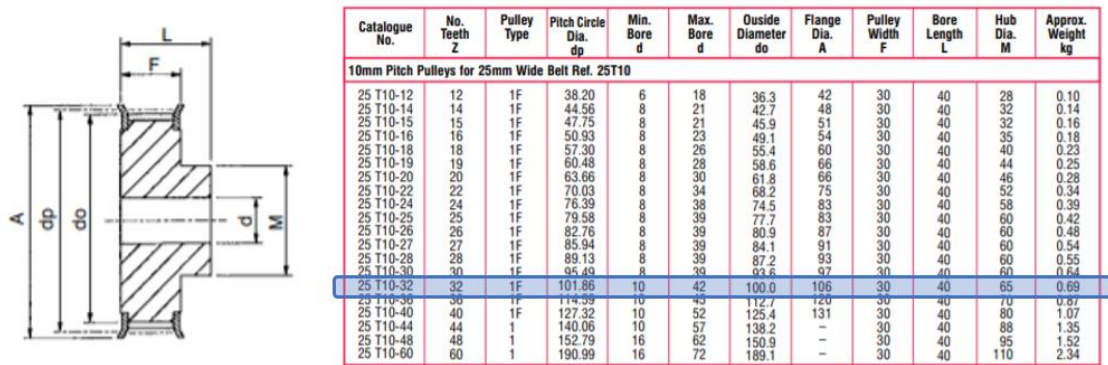

Figure 12.11. Shape and dimensions of the pulley 25-T10-32.

For doing this chapes it is required to save the pulley as a new .ipt. The resulting drawing in Autodesk Inventor can be seen in Figure 12.12.

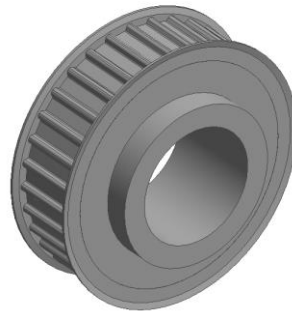

Figure 12.12. Pulley 25-T10-32 with 32 teeth in Autodesk Inventor.

Then, the belt can be selected in the same window as Figure 2.9 and selecting the existing pulleys separated the distance wanted, 1365 mm. This belt rests in a guide line of 26 mm width, one more than the belt, so it does not touch the steel structure and the path it follows is the correct one. This component can be seen in Figure 12.13.

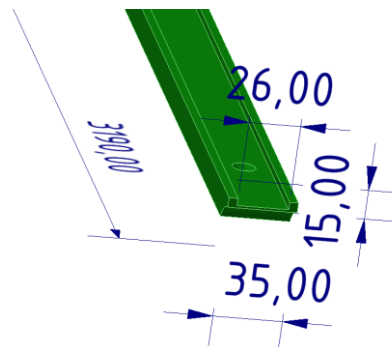

Figure 12.13. Guideline of the belt 25-T10. Dimensions in mm.



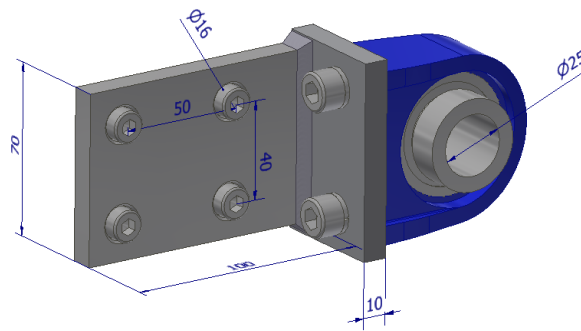

Figure 12.16. Structure on the side to support the axis that connects to the motor and transmits the movement. Dimensions in mm.

They are used to guide the axis that connects to the motor. This is because the driving force in this structure is transmitted directly to the pulleys on one side of the chain conveyor. In this way, the structure is slimmer and longer than in the case of chains, and can be perfectly adjusted to the space available between the rollers of the roller conveyor.

### 12.3.2. MOTOR

The motor chosen for this belt conveyor is exactly the same as the one chosen for the roller conveyor of this structure. The reasons are that the speed wanted are the same, 30 m/min, because I want that machine free as soon as possible, which makes the RPM of 159 1/min. The sprockets that transmit the power from the motor to the axis that connects to the sprocket have the same side. Moreover, the power for transmitting the movement can be also 0.55 kW.

Taking all this in consideration, the motor chosen. In conclusion, the type of motor is the same as in the roller conveyor before the sanding machine, R07DRN80M4, helical gear units R + AC motor DRN (IE3), company SEW, with the same characteristics as the ones explained in section 12.1. *ROLLER CONVEYOR*.

The motor is fixed with the same blue plane and bolts as explained in the section I have just mentioned, and then to an structure that joins it to the main brown structure. The location of this motor can be seen in Figure 12.17.

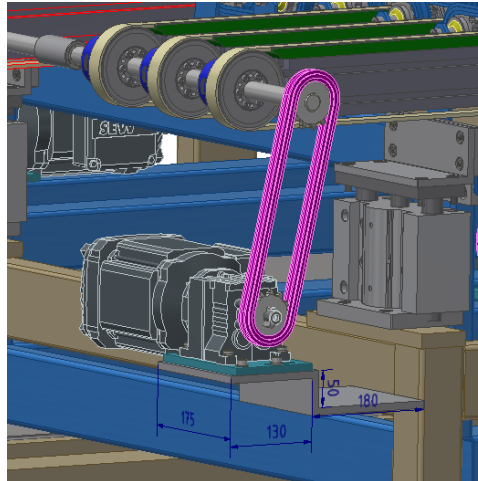

Figure 12.17. Gearmotor R07DRN80M4 located in the belt conveyor. Dimensions in mm.

### 12.3.3. STRUCTURE THAT HOLDS THE BELT CONVEYOR

The structure that holds the belt conveyors is attached to each end of the belts, placing them in the gaps between the rollers. The structure is made of tubes according to DIN EN 10210-2 standard. Some of them have dimensions 100 x 100 x 4, and others 100 x 100 x 50 mm. The floor is supported by parts that make it easier to adjust the highest part of the belts to the desired height, 885 mm. On the highest horizontal tube, a plane of dimensions 1400 x 100 x 20 mm has been placed, on which six L-shaped structures are supported, with the dimensions that can be seen in Figure 12.18. These pieces are spaced in such a way that the distance between belts transporting the same piece of wood is 440 mm, and between both material flows the distance is 420 mm, achieving their placement between the hollows of the rollers.

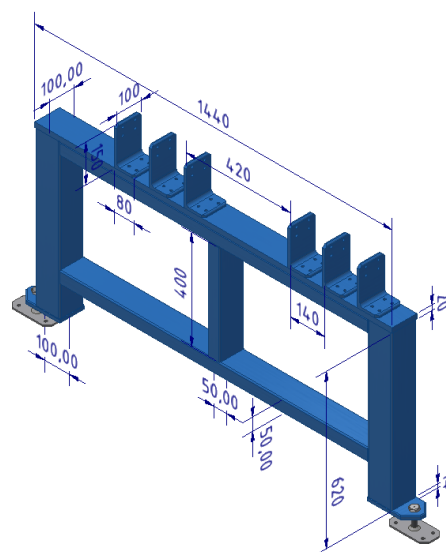

Figure 12.18. Structure situated in the extremes of the belt arms that holds them.

## 12.4. STOPPERS

### 12.4.1 STOPPERS IN THE ROLLER CONVEYOR

When the 14 sheets of wood leave the sanding machine, they must stop in the central position of the three conveyor belts that will transport them. For this reason, stoppers have been placed parallel to the 1100 mm long rollers as soon as they pass the belts, in order to stop all 14 lamellas at the same time and to have a little margin in case of any deviation from the conveyor belts. There are four of these stoppers along the roller conveyor, so they cannot be on top all the time, as the parts would never get past the first one. It is necessary to place four movable stoppers, which move up and down according to the need to stop or let the wooden slats pass over them. This has been achieved by using the cylinders explained in section 8.3.1. PNEUMATIC CYLINDERS, of the type Compact Guide Cylinder MGP-Z, Compact Guide Cylinder MGPM80TF-30Z and of the company SMC. Exactly the same parameters are used as the purpose is the same and the weight of the stoppers to be lifted is similar. The cylinder also has the magnetic sensors M9B - Solid state, general purpose with 2 wires and horizontal also explained in the same section.

The fastening of the cylinder to a structural tube DIN EN 10210-2 of dimensions 80 x 40 x 4 mm, which is fastened to the structure of the roller conveyor, is made with the same as in the lifting table, as well as its screws, shown in Figure 8.9 of the section explaining it *8.3.2 MOUNTING PART*.

The part that has physical contact with the wooden slats is a yellow part of height 1100 x 100 x 10 mm, and whose base fits with that of the cylinder thanks to the screws DIN 6912 M10 X 20 mm.

The fastening of the cylinder to a structural tube DIN EN 10210-2 of dimensions 80 x 40 x 4 mm, which is fastened to the structure of the roller conveyor, is made with the same as in the lifting table, as well as its screws, shown in Figure 8.9 of the section explaining it *8.3.2 MOUNTING PART*.

The part that has physical contact with the wooden slats is a yellow part of height 1100 x 100 x 10 mm, and whose base fits with that of the cylinder thanks to the screws DIN 6912 M10 X 20 mm.

The structure of the stopper with its dimensions can be seen in Figure 12.19.

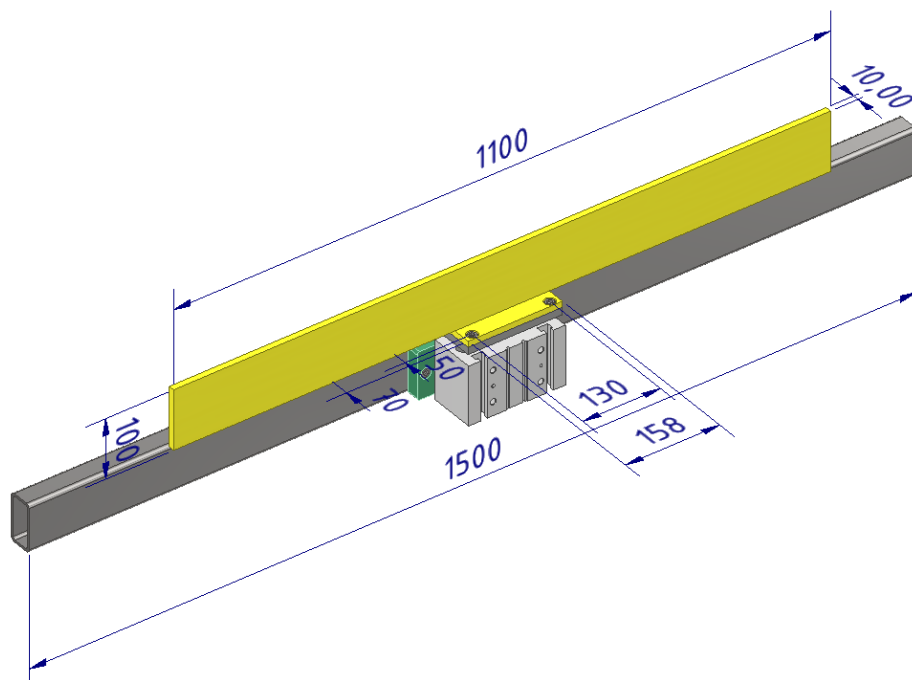

Figure 12.19. Moving stopper in the roller and belt conveyor after sanding machine.

#### 12.4.2. STOPPERS IN THE BELT CONVEYOR

In the end of the belt conveyor there are eight stoppers coloured pink, two per group of three chains that transport the 14 wooden sheets, that are fixed there and do not move. Its main purpose is to stop the group of fourteen oak wooden sheets all together in the same place, so the robot that takes them later know exactly what the position is. They are fixed with DIN EN ISO 4762 M10 x 16 mm bolts. An image of this stoppers with its dimensions can be seen in Figure 12.20.

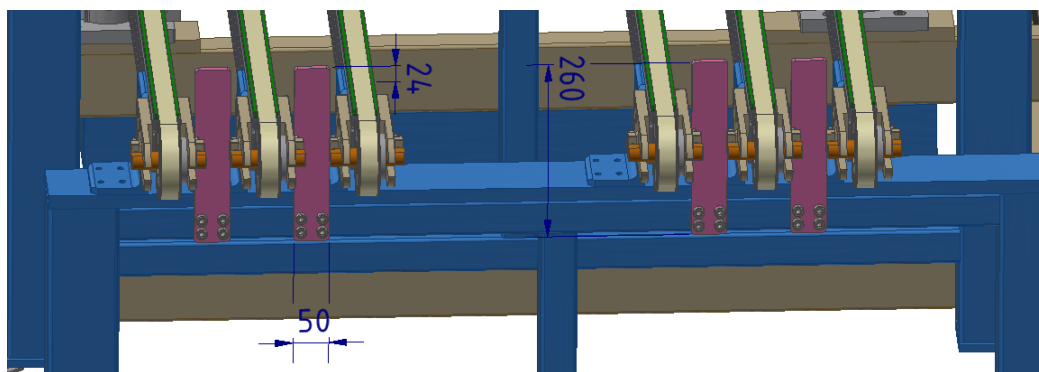

Figure 12.20. Still stoppers in the end of the belt conveyor. Dimensions in mm.

## 12.5. SENSORS

### 12.5.1. SENSORS IN THE ROLLER CONVEYOR

The sensors placed in this machine have more than one function. The photocells already explained in section 7.4.1. *ELECTION OF THE SENSORS* have been chosen. They are from the company SICK, type WL12-3V2431, with article number 1041537. The structures on which this sensor is supported are square tubes DIN EN 20210-2 25 x 25 x 3 mm, length 1500 mm.

In the first still roller conveyor, one is placed at the beginning and one at the end, in order to detect when the sheets pass through and to have control of the material at all times.

In the roller conveyor with movement, one has been placed before each belt conveyor. In addition to controlling where the material is located, they have the function of controlling the cylinders that lift the stoppers and decide whether they go up or down.

In total there are 4 sensors on each machine. Taking into account that there are two machines in a row, 8 photoelectric sensors work together in this section, plus the pair of magnetic sensors that each of the cylinders has: 2 cylinders in each machine for the stoppers, 4 for lowering and raising the conveyor belt, making a total of 24 magnetic sensors between the two machines that are in a row behind the sanding machine.

The operation of the sensors is as follows, assuming that the position of the stoppers is all lowered: the two sensors of the still roller conveyor detect that there is material passing and detect if any type of error occurs. The sensors on the roller conveyor with movement also detect this. The same is true for the next still roller conveyor. The last moving roller conveyor has two sensors: the first one simply detects the passing material, but the next one causes the last stopper to rise and stop all 14 wooden slats at once. The same thing happens with the next set of wooden slats until it reaches the first sensor of the last moving roller conveyor, which raises the second stopper after 0.2 seconds, except if the sensor just behind it detects material on it: in that case it will wait until it detects nothing, which means that the previous group of 14 wooden slats has passed, and it will be raised. This is done until four groups of 14 sheets of wood each are completed, each group in a stopper. At that moment, when the magnetic cylinders are all raised and this is detected by its magnetic sensors, the roller conveyor starts to descend thanks to the other magnetic cylinders that support its structure and whose bore size is 80 mm in diameter, from 900 mm to 870 mm. As soon as it passes the height of 885 mm, the sheets pass from being on the roller conveyor to being on the belt conveyor. When the belt conveyor is fully lowered, the belt conveyor starts to operate.

These sensor can be seen in the Figure 12.21.



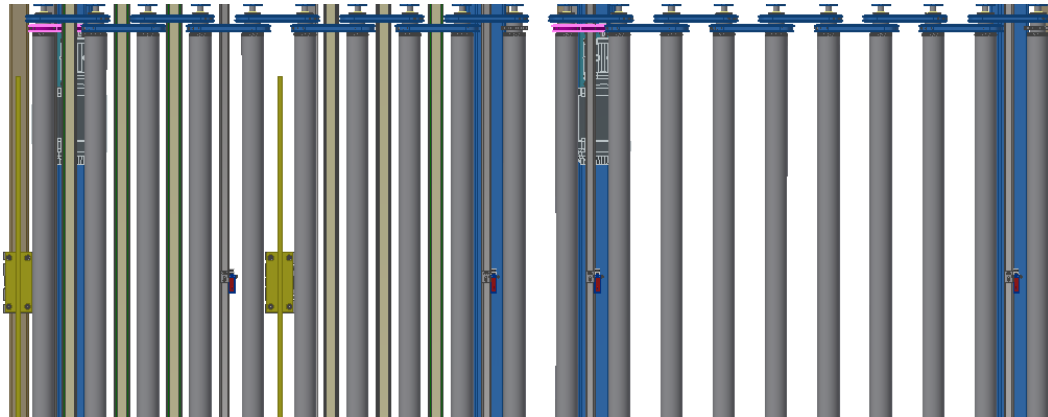

Figure 12.21. View of the position of the sensors from the top in each roller and belt conveyor.

### 12.5.2. SENSORS IN THE BELT CONVEYOR

When the belt conveyor starts to move, other two photocells of the same type and with the same characteristics detect them, so the 14 wooden sheets of each belt conveyor (the two belt conveyors of both machines start moving at the same time) can be counted and detected. Then the second sensors located in the chain conveyors detect the wood sheets. The distance between the first part of the sensor and the stoppers is 40 mm. If the chain goes at a speed of 30 m/min, the 40 mm will be passed in  $0.0013 \text{ min} = 0.08 \text{ seg}$ . In conclusion, the belt must stop almost immediately.

An image of this sensors can be seen in Figure 12.22.

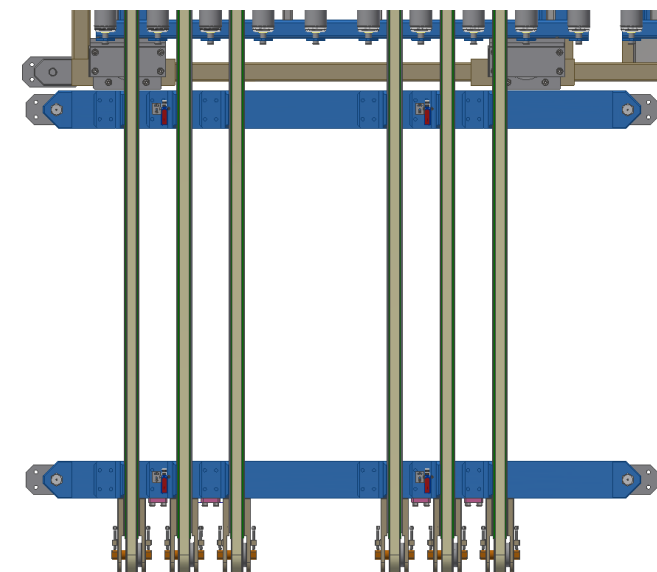

Figure 12.22. View from the top of the four photocell sensors located in each belt conveyor.

## 12.6. BELT AND ROLLER CONVEYOR IN THE LINE

Both belt and roller conveyors in the line are working one after the other, as a whole. They are located after the sanding machine, and the next machine that interacts with the material is a robot with a vacuum gripper. In Figure 12.23 it is shown how the machine looks in the line.

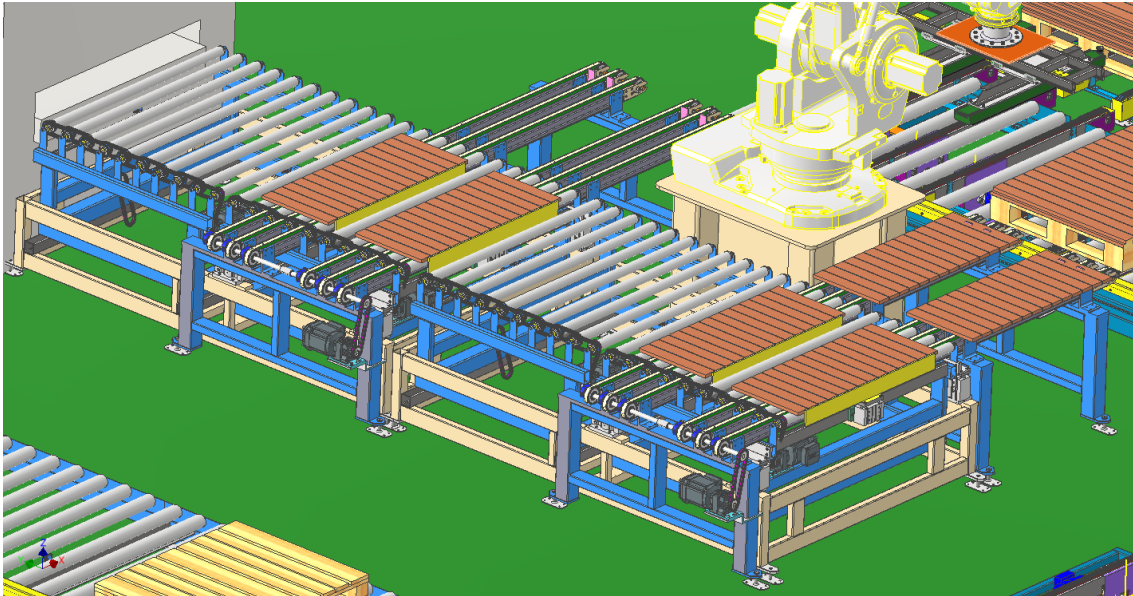

Figure 12.23. Both roller and belt conveyors in the line with wooden sheets on them.

## 13. ROBOT WITH MOVING VACUUM GRIPPING SYSTEM

A robot with a gripper system has to pick up 28 sheets of wood at a time, two of each belt conveyor from the closest ones, and join them together so that there is no space between the two groups of 14 sheets each, and so that they can be placed on a pallet occupying the appropriate space.

The robot chosen is the ABB IRB 760, the same as the one used previously, which is why it has already been explained in section 9.1. *IRB 760 ROBOT*.

This robot is on top of the same table as before, in order to reach better the wooden sheets that it has to take from the belt conveyor and leave them in the chain roller conveyor.

The vacuum systems have also been previously explained in section 9.2. *VACUUM GRIPPERS*.

The cylindrical structure connected to the robot, the orange plane, as well as the I-beam structure are also the same, explained in section 9.3. *CONNECTING STRUCTURE OF THE ROBOT AND THE VACUUM GRIPPING SYSTEMS*. The only difference is the way in which the I-beam structure attaches the vacuum grippers to the structure of the robot, as these vacuum grippers must move together and apart to perform the operation of joining the two rows of material of 14 sheets of wood each. Figure 13.1. illustrates this change.

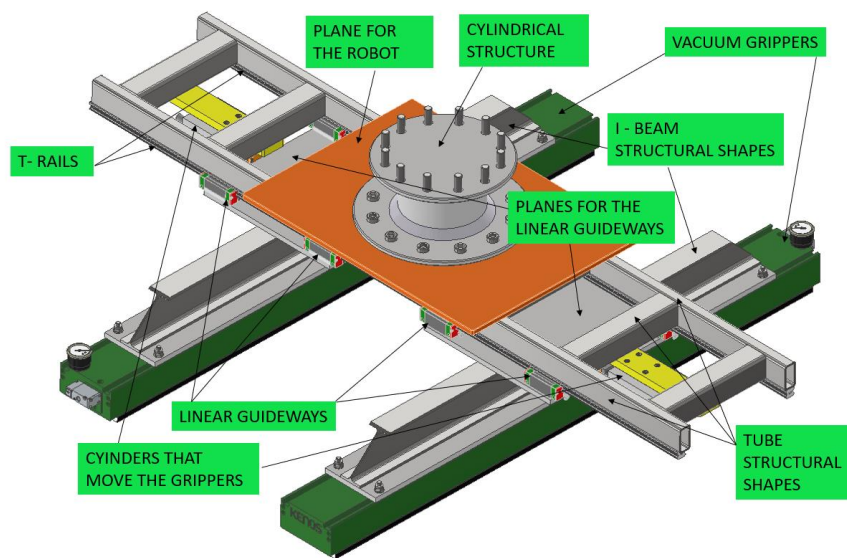

Figure 13.1. Image of the structure that joins the robot with the vacuum grippers.

## 13.1. LINEAR GUIDEWAYS

Linear guides allow linear movement using rolling elements such as balls or rollers. By using recirculating rolling elements between the rail and the block, a linear guide can achieve high precision linear motion. Compared to a traditional slide, the coefficient of friction of a linear guide is only 1/50. Due to the restrain effect between the rails and the blocks, linear guides can take loads in the up and down, as well as left and right directions.

The chosen linear guides are made by HIWIN. This company offers linear guides with the following characteristics:

- High positional accuracy. When a load is driven by a linear motion guideway, the frictional contact between the load and the bed desk is rolling contact. The coefficient of friction is only 1/50 of a traditional contact, and the difference

between the static and dynamic coefficients of friction is small. Therefore, there will not be slippage while the load is moving. Long life with high motion accuracy. Rolling contact has little wear. In consequence, machines can achieve long life with highly accurate motion.

- High speed motion is possible with a low driving force, which results in greater power saving in the moving parts of the system.
- Equal loading capacity in all directions is possible.
- Easy installation following the installation procedure and tightening the bolts to the specified torque.
- Easy lubrication because grease can be easily supplied through the grease nipple on the linear guideway block.
- Interchangeability. If any damage occurs, they can easily be replaced.

The series chosen was HG. The appearance of this linear guideway is shown in Figure 13.2.

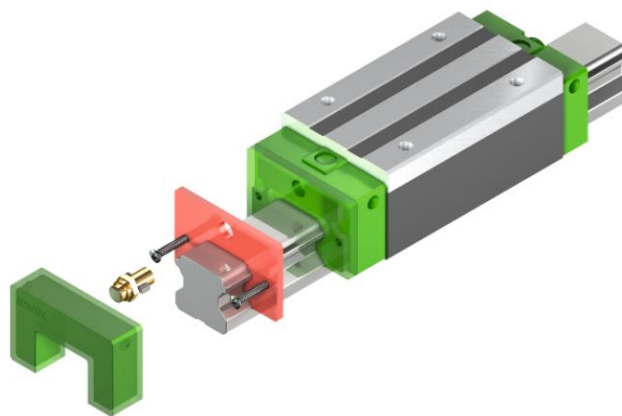

Figure 13.2. Image of the elements of series HG HIWIN Lineal guideway block.

The basic Dynamic load range is between 11.38 kN and 208.36 kN. The load to be lifted is the vacuum grippers. If you look at their data sheet available in annex 2, you can see that their maximum weight is 26 lb, which corresponds to 11.79 kg. Therefore, the force exerted by gravity is:

$$F_{\text{vacuum grippers}} = 11.79 \text{ kg} * 9.81 \text{ m/s}^2 = 115.66 \text{ N.}$$

This is in addition to the 14 wooden slats that each gripper holds, so that this force is more than enough to lift and move them between a total of eight elements.

$$F_{\text{wooden sheets}} = 14 \text{ wooden sheets} * 800 \text{ kg/m}^3 * 8 * 10^{-3} \text{ m}^3/\text{wooden sheet} * 9.81 \text{ m/s}^2 = 878,98 \text{ N}$$

In total, I have 994.64 N, so they can be carried by the linear guides of this series more than enough.

HG series linear guides with four ball tracks are designed with higher load capacity and stiffness than other similar products with circular arc groove and optimised structure. They feature equal load carrying capacity in the radial, reverse radial and lateral directions due to the 45° arrangement of the ball tracks. They are self-aligning to absorb installation error. In addition, they achieve high speeds, high accuracy, smooth linear motion and long service life. Las características son:

- Block type: H, high square block.
- Size 20.
- Load type C, heavy load.
- Block mounting: A, from above.
- Blocks per rail: 2.
- Rail mounting T, from below. It can be seen in the Figure 13.3.



*Figure 13.3. Scheme of a T-rail/Mounting from below.*

- Rail length: 1400 mm.
- Block preload: Z0, that means light preload.
- Precision code H. It means high.
- Sealing system SS. It means standard and seal, with very good sealing effect and minor displacement resistance. Without scrapper.
- Rails per axis: 1.
- Self lube type N, that means without oil lubrication unit.
- Coating HICOAT\_CZS. It is a very thin zinc coating that offers a very good corrosion protection, even on radii and chamfers. Smaller bare parts stay protected by the cathodic corrosion protection. This means significantly higher periods of use. The rail ends are preserved with a high-quality zinc spray that contents 99% zinc. The technical data, as well as the model number of coatings is explained in Figure 13.4.

## Technical data:

Salt spray test DIN EN ISO 9227 [h] <sup>1)</sup>	300
Maximum rail length (single-piece) [m]	4,0

<sup>1)</sup> Unloaded rail

<sup>2)</sup> Also available in black (longer delivery time)

## Model number for coatings:

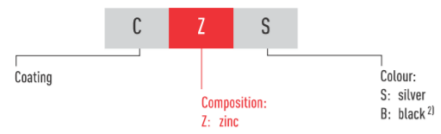

Figure 13.4. Technical data and model number for coatings of HIWIN Coating HICOAT CZS.

- Lubrication condition preserved: carriage not lubricated, lubricate before start-up.
- Grease type G03, clean room applications and high speed.

The name of the profiled rail guideway chosen is HGH20CA2T1400Z0H+CZS. An image of the selected lineal guideway with a cut to see the balls inside that allow the movement can be seen in Figure 13.5.

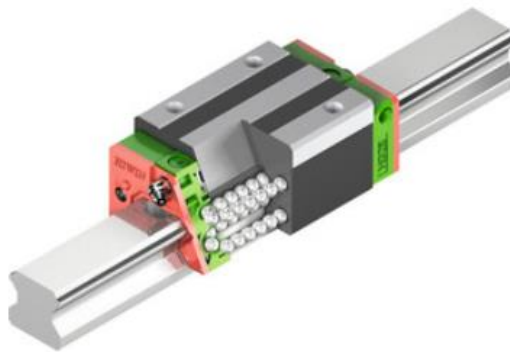

Figure 13.5. Image of lineal guideway HGH20CA of HIWIN.

A dimensional drawing can be seen in Figure 13.6.

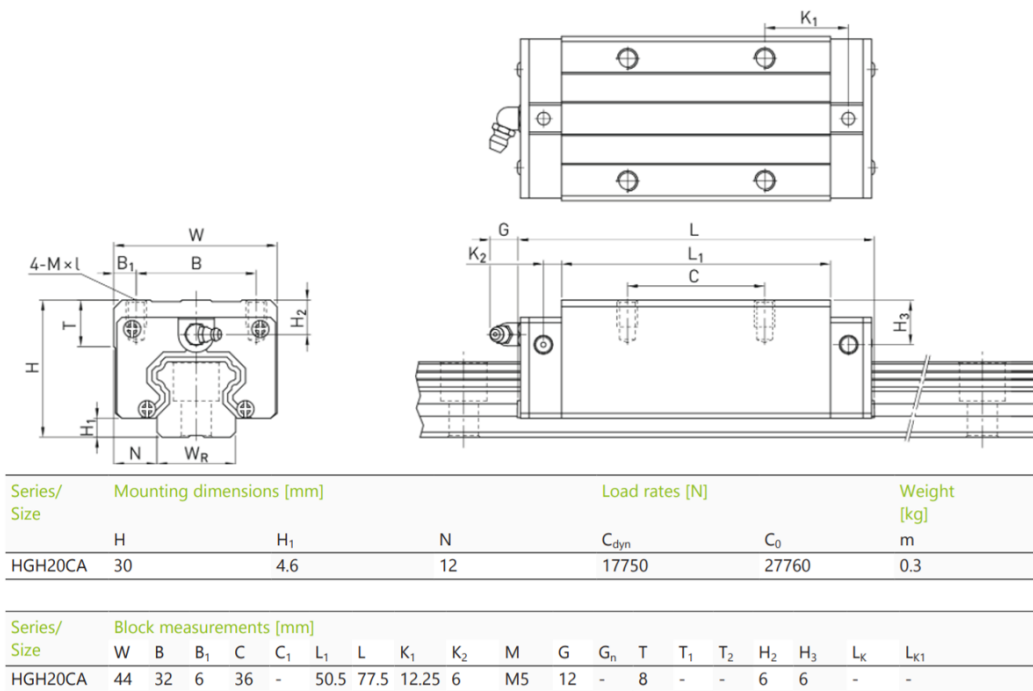

Figure 13.6. Dimensional drawing of lineal guideway HGH20CA of HIWIN. Dimensions in mm.

The moments this lineal guideway has are shown in Figure 13.7.

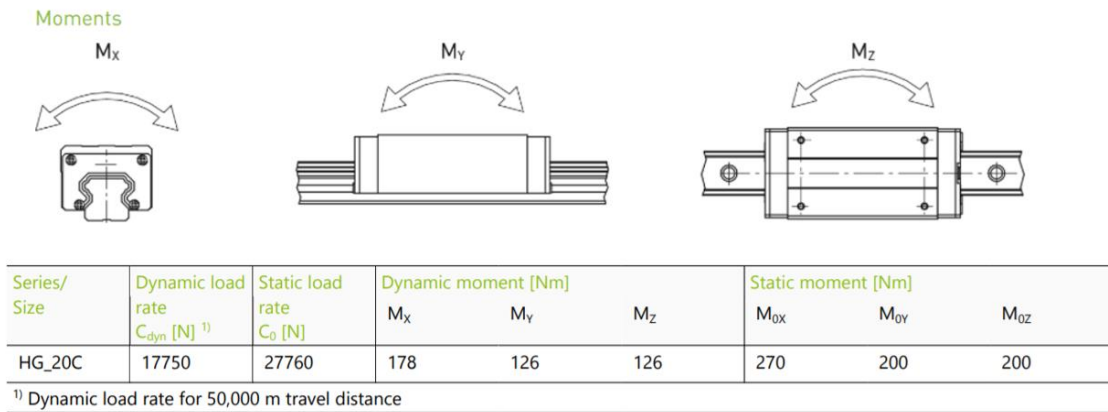

Figure 13.7. Moments of the block of HGH20CA2T1400Z0H+CZS by the company HIWIN.



A dimensional drawing of the rail is illustrated in Figure 13.8.

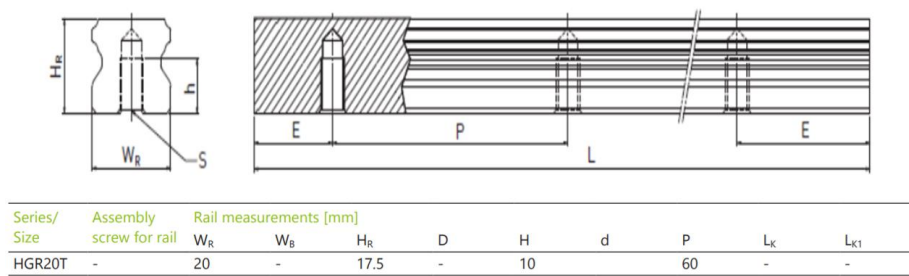

Figure 13.8. Dimensional drawing of the rail of the HGH20CA2T1400Z0H+CZS by the company HIWIN.

For more technical information, the datasheet of the assembly is available in the annex 2.

The CAD drawing obtained is shown in Figure 13.9.

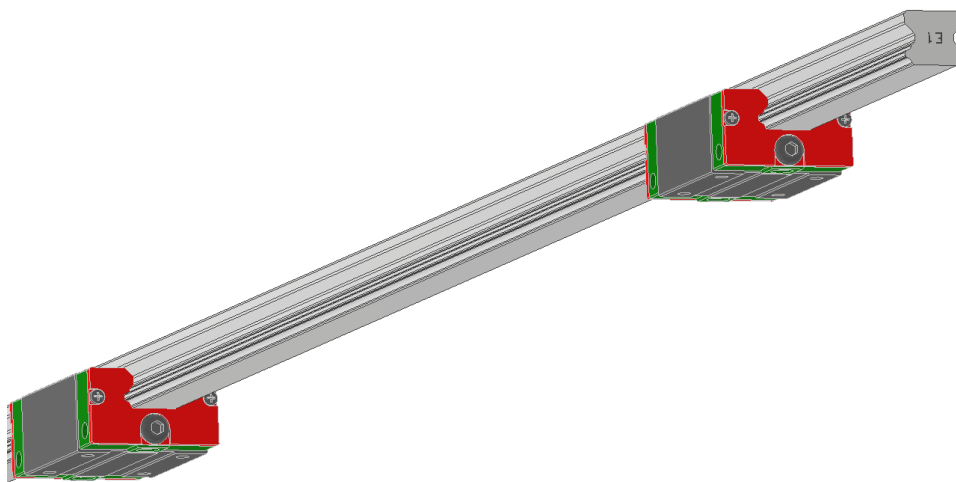

Figure 13.9. CAD drawing in Autodesk Inventor of the assembly block + rail of a lineal guideway HGH20CA2T1400Z0H+CZS by the company HIWIN.

In Autodesk, the number of blocks has been changed to four on each rail. Two rails have been placed on the 1400 mm rectangular tube-shaped structures. Two blocks of each rail have been connected to the two blocks of the opposite rail with a plane of dimensions 300 x 300 x 10 mm. A picture of this assembly can be seen in Figure 13.10.

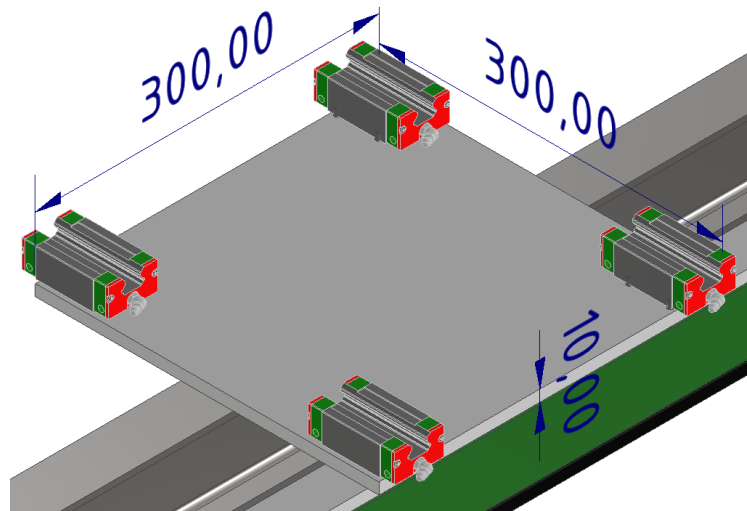

Figure 13.10. Image on Autodesk Inventor of four blocks of lineal guideways joined by a plane.  
Dimensions in mm.

## 13.2. CYLINDERS THAT MOVE THE LINEAR GUIDEWAYS

The cylinder used is of the same type as for lifting the stoppers, explained in section 8.3.1. PNEUMATIC CYLINDERS. It is made by SMC and its name is MGPL50TF-100Z-M9B. The two changes are:

- The Stroke instead of 30 mm is now 100 mm. This is because the two groups of wooden slats are 200 mm apart, so each vacuum gripper has to be moved by 100 mm so that they can meet.
- The bore size is now 50 mm diameter. That implies that the theoretical cylinder force, advance stroke is 982 N and return stroke 855N, enough for moving the linear guiderails, while the maximum piston speed is 500 mm/s.

The CAD drawing of this cylinder is illustrated in Figure 13.11.

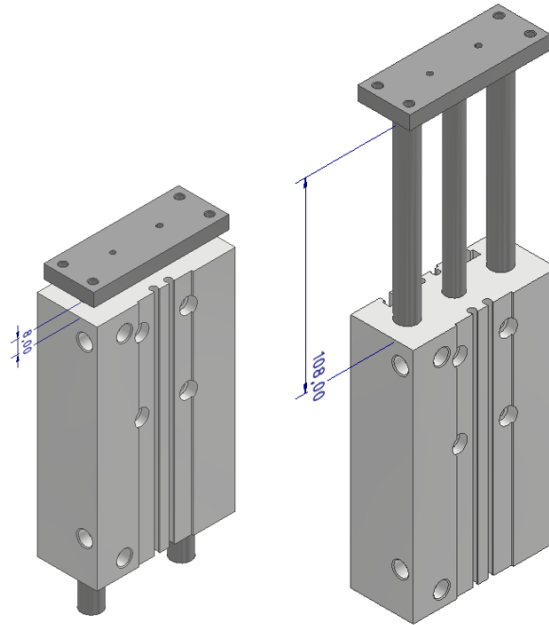

Figure 13.11. CAD drawings in Autodesk Inventor of the MGPL50TF-100Z-M9B cylinder up and down. Dimensions in mm.

There are two magnetic sensors M9B--Solid State, Gen. Purpose, 2 Wire, Horizontal in this cylinder to detect if it is extended or contracted.

For more information on this cylinder, refer to the datasheet available in annex 2.

The cylinder has been attached to the structure from one of its lateral parts to the square tubes that are perpendicular to the rails. For this purpose, a 240 x 50 x 20 mm plane has been used, fastened to the structure with two din 6912 M5 x 25 mm screws and four other screws that hold the cylinder.

In the moving part of the cylinder, a plane has been placed that is welded to the plane that joins the four linear guides and will therefore be the one in contact with this plane, avoiding direct contact with the cylinder.

An image of this assembly can be seen in Figure 13.12.

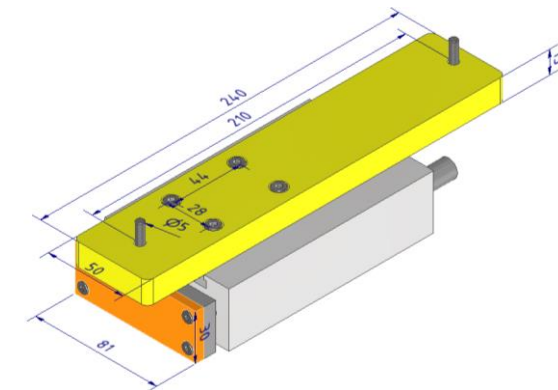

Figure 13.13. Structure of the MGPL50TF-100Z-M9B cylinder joined to the structure of the robot. Dimensions in mm.

### 13.3. ROBOT WITH MOVING VACUUM GRIPPERS IN THE LINE

The robot is programmed to perform the movement of picking up fourteen sheets of wood with each of the vacuum grippers, lifting, joining them with the movement of the cylinders, and placing them on the pallets that are on the roller and chain conveyor chains and then leaving the line. As the robot is in the middle of each flow pair of wooden slats, it is not necessary for the roller and chain conveyor to be on a lifting table. A picture of the robot on the line can be seen in Figure 13.14.

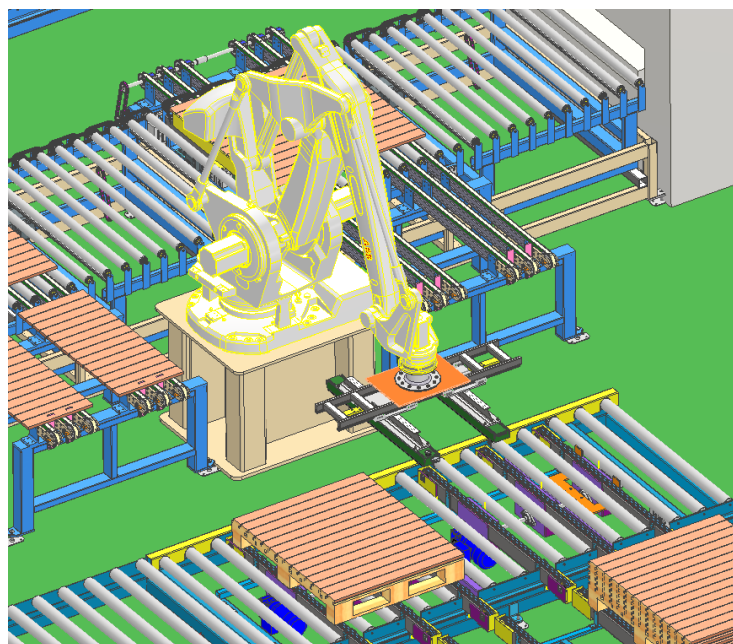

Figure 13.14. Robot that takes two rows of fourteen wooden sheets and puts them together working in the line.

## 14. ROLLER CONVEYORS FOR THE PALLETS

The roller conveyors which purpose is transporting the pallets they do it at a height of 285 mm. The reason why is that the chains that enter and go out of the line have to do it at 300 mm, so when changing the direction these rollers are used and the chains go down 30 mm helped by pneumatical cylinders. This mechanism will be explained in the next section. The length of the machine is 3800 mm and the width 1610 mm. An image of this machine is illustrated in Figure 14.1.

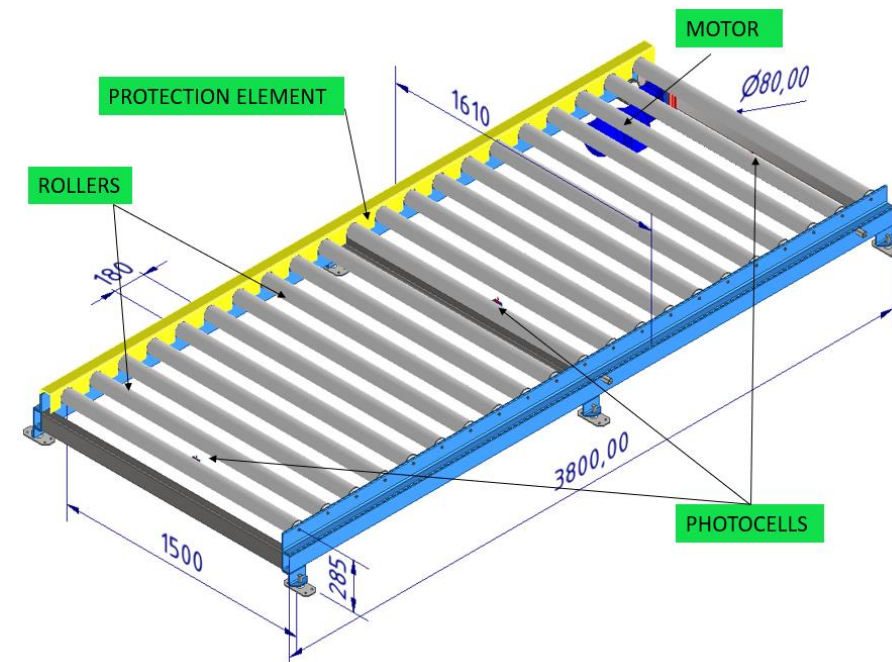

Figure 14.1. Roller conveyor for transporting the pallets, with dimensions in mm.

### 14.1. ROLLERS

The rollers conveyors that transport the pallets have been designed with Interroll rollers. Bearing in mind that each pallet is 25 kg, as mentioned in section 4.2. *ASSUMPTIONS MADE*, the force that these rollers must withstand is:

$$F_{\text{pallets}} = 25 \text{ kg} * 9.81 \text{ m/s}^2 = 245,25 \text{ kg*m/s}^2.$$

Considering this calculation, the roller chosen has been the heavy-duty conveyor roller Series 3600. The characteristics of this product are the following:

- Outstanding low-noise operation to the drive heads are made of fibreglass-reinforced, viscoplastic polyamide.
- Drive elements secured against twisting and axial movements against the tube.
- Gentle lateral pushing of the materials to be conveyed.

- Sealed precision ball bearing (6204 2RZ, 6205 2RZ)
- The main application is in-house driven conveyance of heavy materials to be conveyed, as the pallets.

The technical characteristics of this roller can be seen in Chart 14.1.

<b>General technical data</b>	
Max. load capacity	3,500 N
Max. conveyor speed	0.50 m/s
Temperature range	0 to +40 °C
<b>Materials</b>	
Bearing housing	Polyamide
Drive head	Polyamide
Seal	Polyamide
Ball bearing	Steel 6204 2RZ, 6205 2RZ

The dynamic load and the surface load are the assumptions for the load capacity.

Chart 14.1. Technical data of the heavy-duty conveyor roller Series 3600 from Interroll.

The specific parameters chosen for the rollers are shown in Figure 14.2.

Article \*  
Heavy-duty Conveyor Roller Series 3600

Drive Type \*  
Sprocket PA 5/8" T15 single

Tube Diameter \*  
80 mm

Shaft Type \*  
Female Thread

Extension  
0 mm - 95 mm (If extension is > 3mm, two circlips will be added which add up to EL)  
30

Female Thread \*  
M10

Sleeve \*  
None

EL \*  
300 mm - 1600 mm  
1500

Figure 14.2. Parameters chosen for the heavy-duty conveyor roller Series 3600 from Interroll.

According to those dimensions, the force each roller can stand is shown in the next Chart 14.2.

Ø Tube mm	Torque transmission	Max. load capacity in N with an installation length of mm							
		200	400	600	800	1,000	1,200	1,400	1,600
80 x 3	Polymer sprocket	3,500	3,500	3,500	3,500	3,500	3,500	3,500	3,500
89 x 3									
80 x 3	2 polymer sprockets or	3,500	3,500	3,150	3,000	2,930	2,880	2,850	2,820
89 x 3	toothed belt head								

Chart 14.2. Force each heavy-duty conveyor roller Series 3600 from Interroll can stand according to its length.

As the length of the roller chosen is 1500 mm with 2 polymer sprockets, it can stand a maximum load capacity between 2850 and 2820 N. The rollers will have a space between one and other of 180 mm so they can easily hold the pallets that apply a force of 245,25 kg\*m/s<sup>2</sup>.

The dimensions of this roller are the ones indicated in Figure 14.3.

Dimensions for 2 polymer sprockets 5/8", without flange

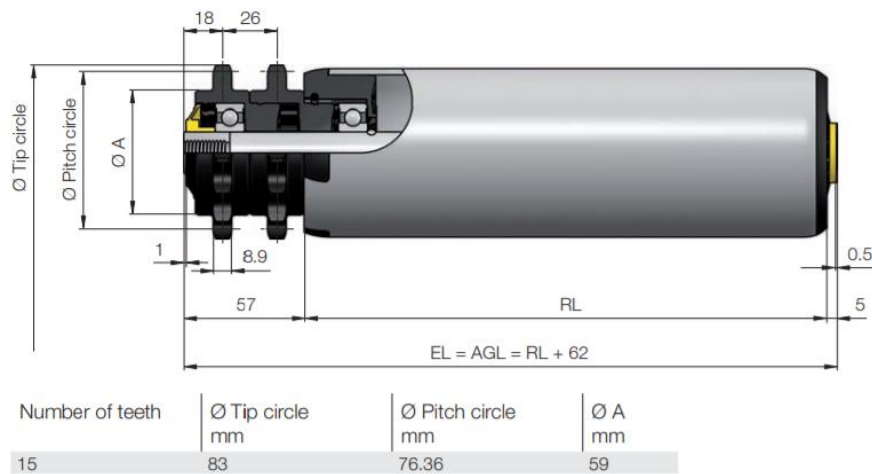

Figure 14.3. Dimensions of the heavy-duty conveyor roller Series 3600 from Interroll.



The CAD drawing obtained is shown in Figure 14.4.

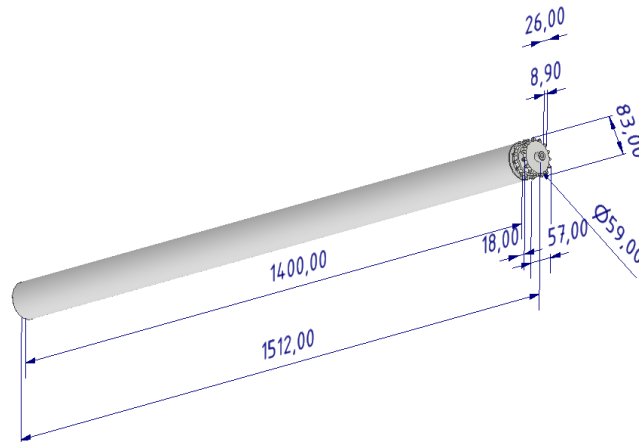

Figure 14.4. CAD drawing in Autodesk Inventor of the heavy-duty conveyor roller Series 3600 from Interroll. Dimensions in mm.

For more information about this roller the details can be checked in the documentation included in annex 2.

## 14.2. MOTOR

The motor chosen is from the company SICK. The speed wanted is around 15 m/min. If I choose the same one as in the chain conveyor that transports pallets without load on them, I have the linear speed:

$$V_c = \frac{\pi \times 83 \text{ mm} \times 57 \text{ 1/min}}{1000 \text{ mm/m}} = 14.86 \text{ [m/min]}$$

14,86 m/min is an acceptable speed, so I will use the same motor- Its name is SK 1SI63 - IEC80 - 80LP/4 B14 C120. As it was previously described in the chapter 7.2.2 CHOICE OF MOTORS, all the information is already explained.

The movement is transmitted by chains, as in the roller conveyors before and after the sanding process.

## 14.3. GENERAL STRUCTURE

The rollers are hold by one L-shaped structure DIN EN 10056-1- L100x50x8 mm and length 3800 mm on each side, with holes every 180 mm of 13 mm to insert the rollers. That structural shapes rests in a DIN EN 10210-2 100x50x4 mm 3800 mm length

rectangular tube. Each rectangular tube rests in four legs welded to it and created with the shape and dimensions shown in Figure 14.5.

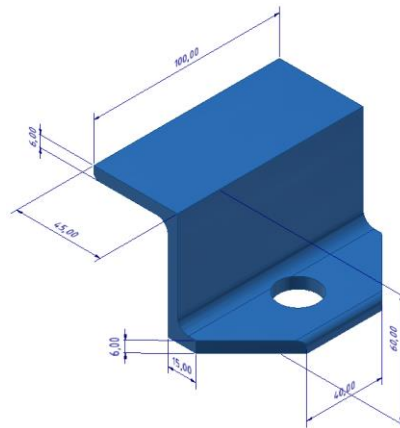

Figure 14.5. Legs of the roller conveyor that transports empty pallets. Dimensions in mm.

Inside the hole, an structure consisting of a bolt and a plane is introduced that connects to the floor and allows changing the height of the machine to be changed even after being installed, because it is so important that the height of the machine is exactly 285 mm as I explained before.

That structure has two perpendicular DIN EN 10210-2 100x50x4 mm 1510 mm length tubes.

The part of the sprockets and chains is covered by a yellow plastic part, welded to the rectangular tube on that side, in order to protect the workers to get injured, and also to prevent dust entering in the mechanism and deteriorating it. This component is explained in Figure 14.6.

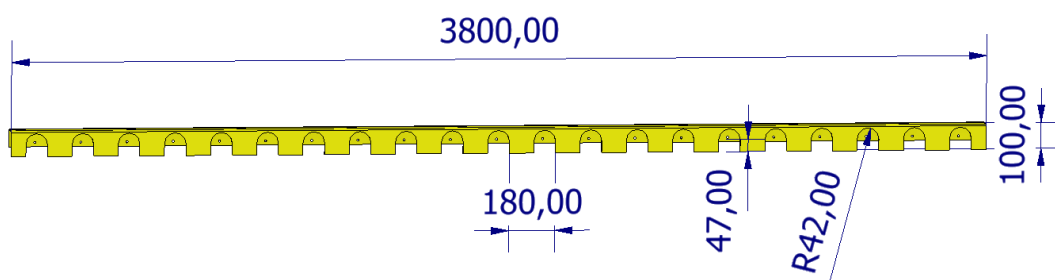
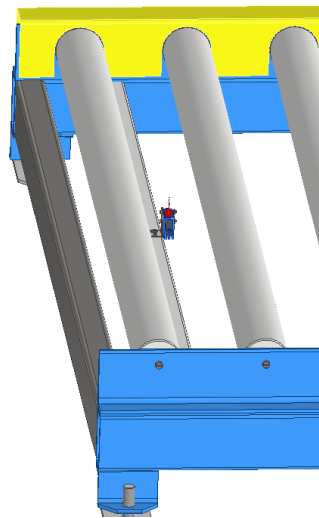

Figure 14.6. Protective component of the sprockets of the rollers.

## 14.4. SENSORS

The roller conveyor has three photocells to detect the pallets passing on top of them. The sensor is the same one used in the chains, from the company SICK, type WL12-3V2431, with article number 1041537. That sensor is detailed in the section 7.4.1. *ELECTION OF THE SENSORS*.

They are located equidistantly, between the rollers, one on the entrance of the pallet, other in the middle and the other in the end. In total is three sensors, enough for knowing where the pallet is in every moment. A picture of the position of one of these sensors, that are located on top of DIN EN 10210-2 50x50x4 mm 1510 mm rectangular tubes, is seen in Figure 14.7.



*Figure 14.7. Close view of a WL12-3V2431 photocell from SICK, located in the roller conveyor to detect the presence of pallets on it.*

## 14.5. ROLLER CONVEYORS THAT TRANSPORT PALLETS IN THE LINE

The roller conveyors are used to transport the pallets in the direction perpendicular to the chains that also transport them before and after. Three of these roller conveyors are needed in order to fulfil their duty and complete the path to transport the pallets from the beginning to the end of the line.

A picture of these rollers on the line is viewed in Figure 14.8.

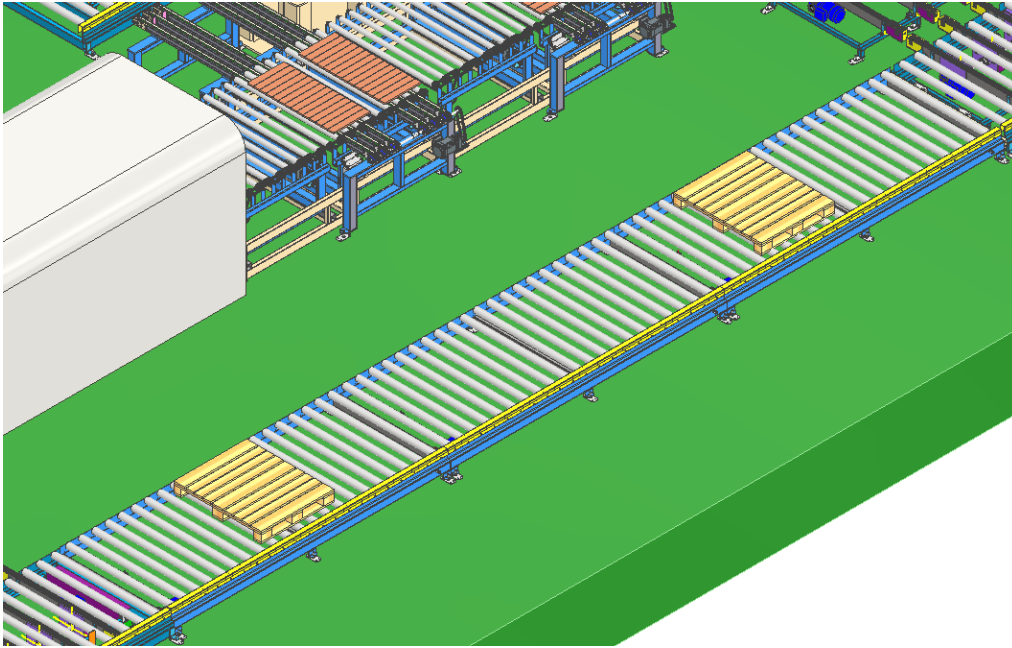

Figure 14.8. The three roller conveyors transporting pallets in the line.

## 15. ROLLER AND CHAIN CONVEYORS

These are machines in charge of changing the direction of the pallets as they are transported from the beginning to the end of the line. To do this, the chain conveyor lowers its height and leaves the pallets to the roller conveyor, or on the contrary, it goes up and picks them up from the roller conveyor, depending on where the machine is located in the line. Therefore, the chains are sandwiched between the rollers, forming a joint structure even though they are actually two separate machines but designed for a common purpose.

There are four different variations with small changes from one another due to the function they perform and the position they are in on the line:

- In the first, two pallets come conveyed by the chain conveyor at a time. Fixed stoppers stop them at the end of the chain conveyor, at which point the chains are lowered by 30 mm, from 300 mm to 270 mm, in order to leave the pallets resting on the roller conveyor, which is at a height of 285 mm. At this point, the rollers are set in motion and the two pallets go on them, one after the other, having changed direction. This corresponds to Figure 15.1.

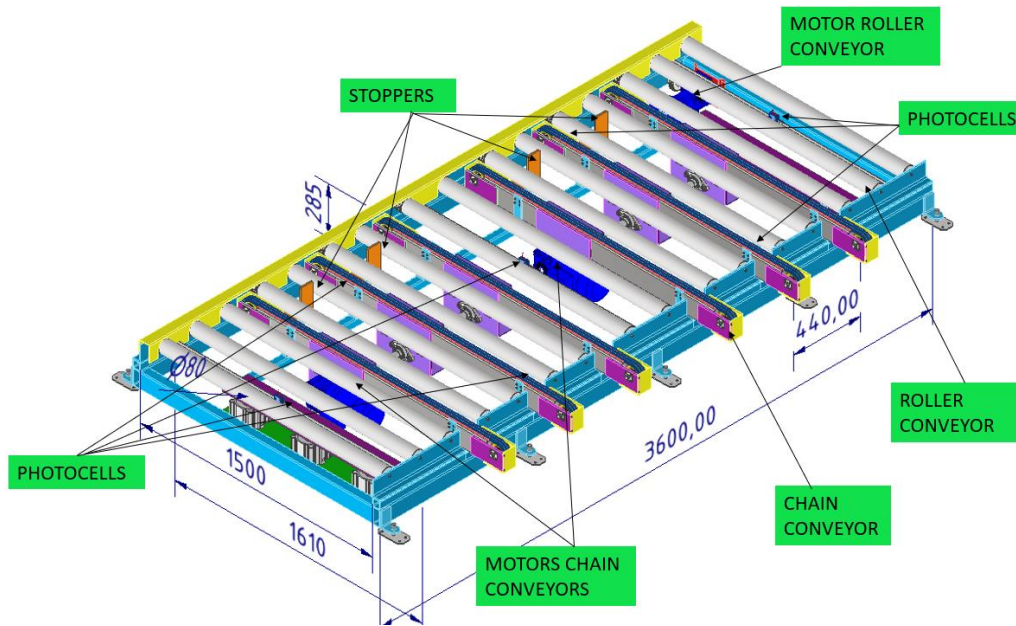

Figure 15.1. First roller chain conveyor that transports pallets. Dimensions in mm.

- In the second, the pallets come down the roller conveyor one at a time. When the travel in that direction ends, stoppers stop the pallet. The chains then move up from the height of 270 mm to 300 mm, picking up the pallet that was previously on the rollers at 285 mm, and the pallets move forward on the chain having changed direction again. while the chain is moving up or down, no other pallet enters the machine to ensure correct operation because the previous roller conveyor will stop so that does not happen. This machine can be seen in Figure 15.2.

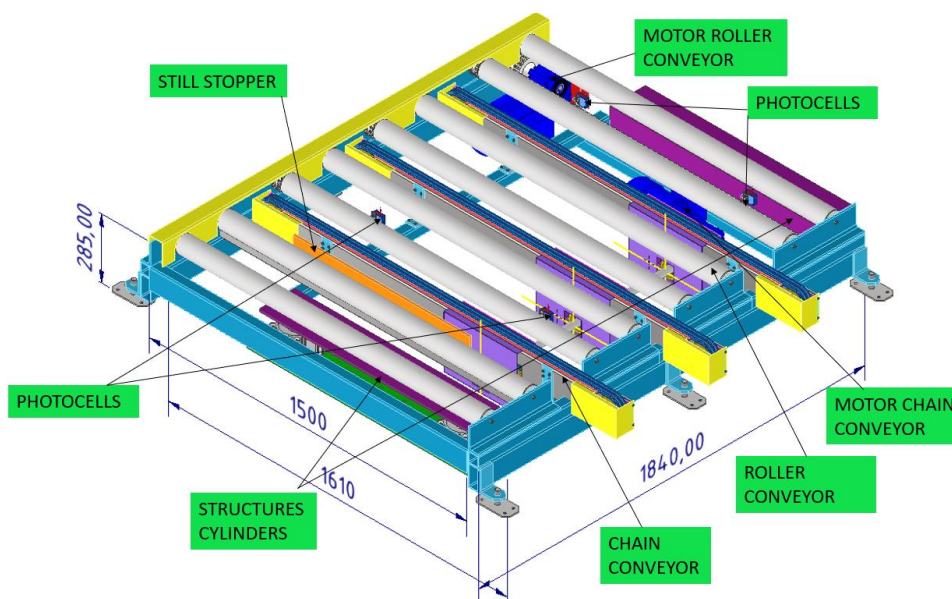

Figure 15.2. Second chain roller conveyor transporting pallets. Dimensions in mm.



- In the third chain roller conveyor, a pallet comes on the chain conveyor. It is stopped by the stoppers, at which point the chains lower by 30 mm to leave the pallet on the roller conveyor. The pallet continues its course in another direction. This machine has a slightly longer roller part in order to be able to join the next element. This is the machine in Figure 15.3.

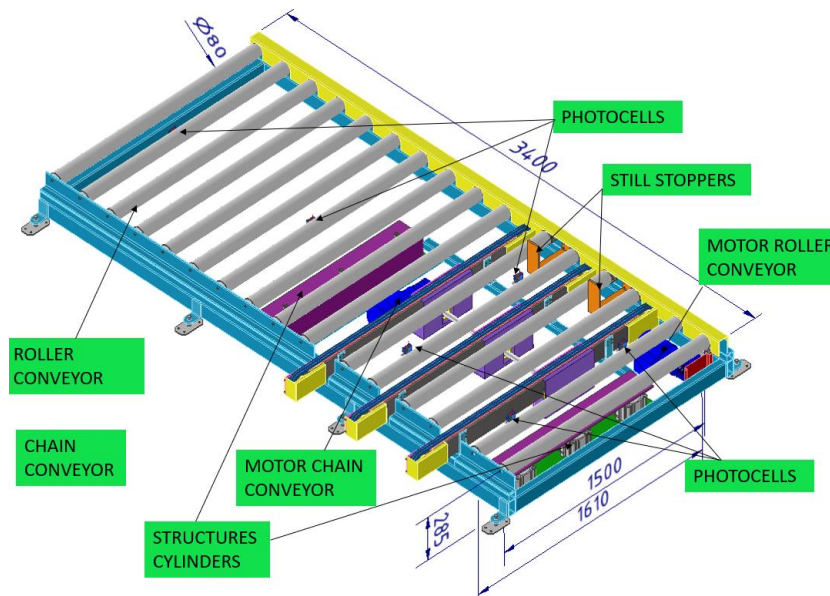

Figure 15.3. Third chain roller conveyor transporting pallets. Dimensions in mm.

- The fourth chain roller conveyor is similar to the first one, the only thing that changes is the way the stoppers are positioned. There is one in the middle of the roller conveyor that goes up and down and one at the end that is stationary. This is because at the exit of the line there is a double pallet flow, so there are two chain conveyors on the line. In Figure 15.4. this machine is pictured.

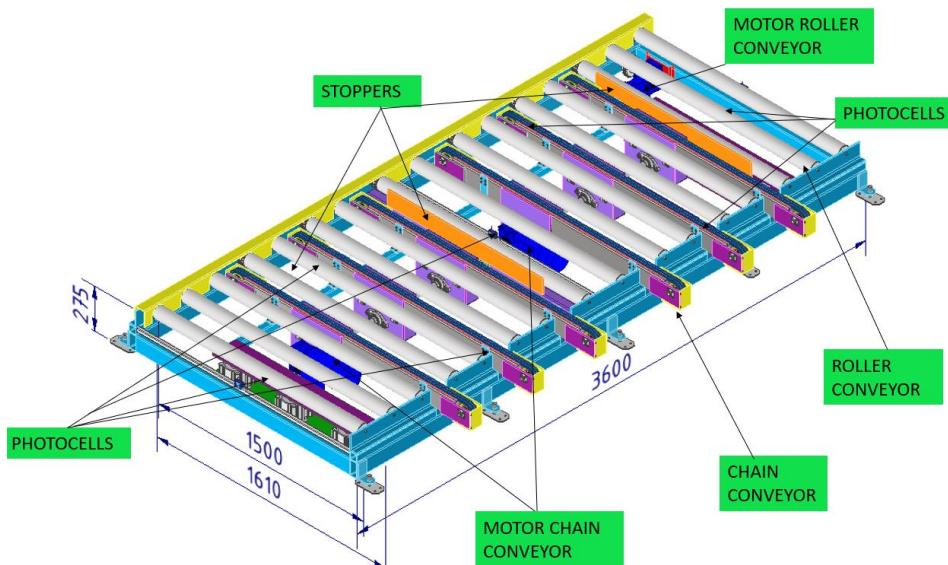

Figure 15.4. Fourth chain roller conveyor transporting pallets. Dimensions in mm.

The structures in general are very similar, so we will proceed to talk about them as a whole and then go on to detail the differences.

## 15.1. CHAIN CONVEYORS

The structure of the chain conveyor is exactly the same as the one through which the pallets come in and out of the line. For more details on this machine, see section 7. *CHAIN CONVEYOR FOR THE PALLETS.*

The only change is the way it rests on the floor. As this chain conveyor has to go up and down to be able to leave the pallet on the roller conveyor, or pick it up from it, depending on its position, a mechanism capable of supporting the weight of the entire structure is needed. The solution chosen is the placement of six cylinders on both sides that are responsible for raising and lowering the structure as desired.

The cylinders chosen are from SMC. The type is Compact Cylinder - CQ2-Z. This cylinder has the advantages of:

- It is compact, does not take up much space, which suits me as I have to be able to put it under the whole structure.
- It is light, 456 g, while the productivity remains high.

A picture of this type of cylinder can be seen in Figure 15.5.



*Figure 15.5. Image of Compact Cylinder – CQ2-Z from the company SMC.*

The desired cylinder has the following characteristics:

- Cylinder acting: double acting.
- Cylinder stroke: 5 to 100 mm.
- Cylinder bore size: from 125 to 200 mm.
- Not required special environment.



- Rod type: single rod.
- Stroke type: single stroke.
- Cylinder type: none.

Once these characteristics have been chosen, the desired parameters must be selected. This can be seen in Figure 15.6.

Magnet

D (Built-in) ✓

Bore Size

Ø125 mm ✓

Port Thread Type

TF (G) ✓

Stroke

30 mm [10 mm to 300 mm] by 1 ✓

Body Option

Standard (Rod End Female Thread) ✓

Auto Switch

M9B--Solid State , Gen. Purpose, 2 Wire, Horiz... ✓

Lead Wire or Prewired Connector

0.5 m or None in the Case of No Switch ✓

Number

2 pcs. ✓

Figure 15.6. Parameters chosen for the Compact Cylinder – CQ2-Z from the company SMC.

Once the parameters have been selected, I now have the full name of the cylinder: CDQ2B125TF-30DCZ-M9B. The explanation of this name can be seen in Figure 15.7.

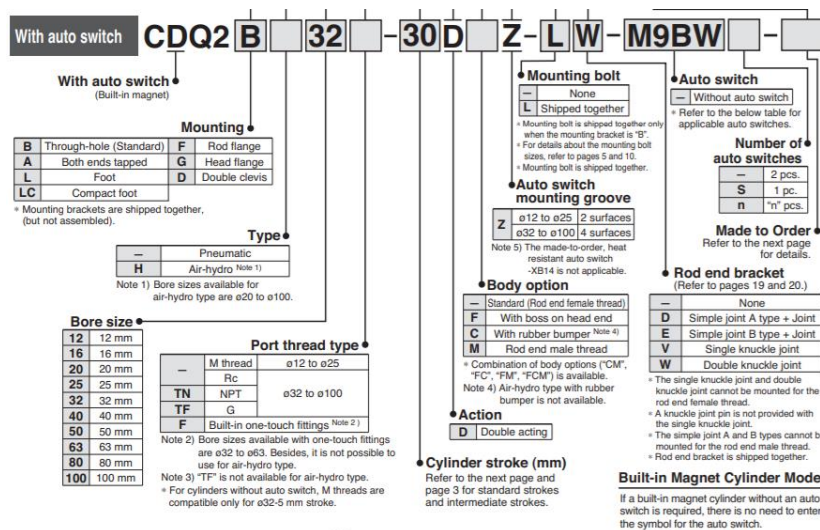

Figure 15.7. Explanation of the name of the Compact cylinder CDQ2 with auto switch.

It is important also the component parts of this cylinder, as well as the materials with which the cylinder is built. Figure 15.8 illustrates this information with a drawing and a chart explaining it.

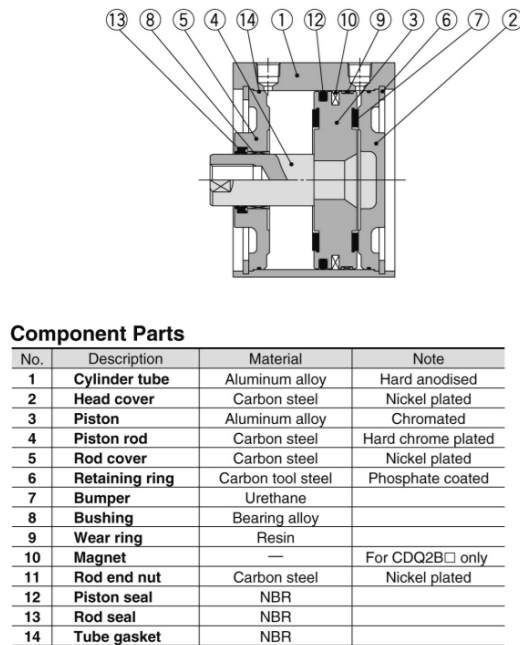

Figure 15.8. Drawing and chart explaining the component parts of the compact cylinder CDQ2 and its materials.

The dimensions of the cylinder chosen can be seen in Figure 15.9.



Figure 15.9. Dimensions of the cylinder Compact cylinder CDQ2 with auto switch.

It is also known that the theoretical force of the cylinder, advance stroke is 5627 N and return stroke 6136 N. With this I can conclude that with six cylinders it is enough to be able to lift and lower the structure without any problem.

For more information about this cylinder, the datasheet is included in the annex 2.

The cylinders are to be positioned in such a way that they lift the square tubes on the sides of the chains. Three cylinders are needed on each side. These three cylinders will rest on a 110 x 80 x 10 mm plane. This plane has holes in it so that the DIN EN ISO 4762 M10 x 100 mm screws which fit into the four corners of the cylinders can be anchored.

On top of the cylinders, a structure is needed, the shape of which should lower the base of the support point, as the cylinders are higher than I need. With this structure, the support point can be lowered without losing the force exerted by the cylinders and with the same functionality. This purple structure is joined in to the cylinders with DIN EN ISO 4762 M18 x 1,5 x 30 mm bolts. The part that will hold the chain conveyor has 12 DIN EN ISO 4762 M10 x 20 mm bolts distributed in three rectangular shapes. An image of this structure can be seen in Figure 15.10.

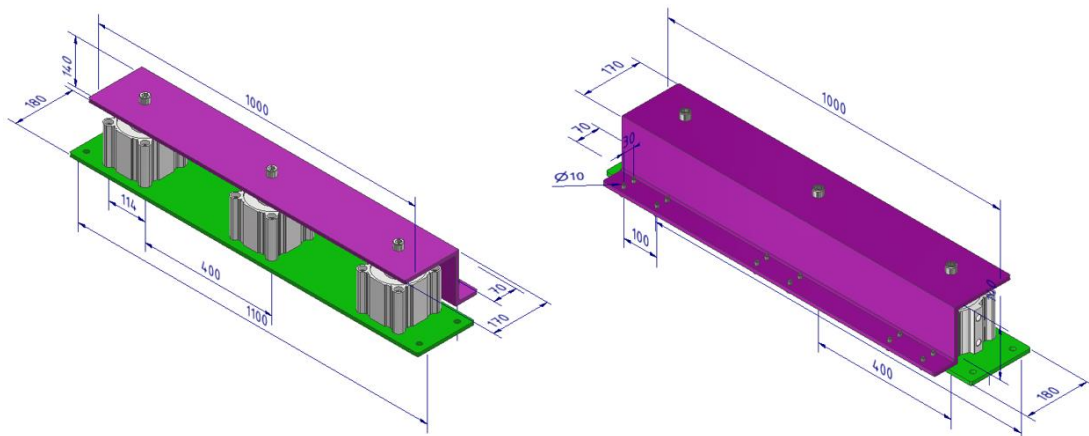

Figure 15.10. Views from the front and the back of the structure of the cylinders that lift the chain conveyors. Dimensions in mm.

The chains have the same sensors than the roller chains alone, so they detect when the pallets are passing over the chains. Consequently, they are responsible of activating the movement of the chains up and down once the pallet has been detected to be on the right position: some milliseconds after being detected by the second photocells located on the chain.

## 15.2. ROLLER CONVEYORS

The roller conveyors are positioned at a height of 285 mm above the floor. The roller conveyors used were selected from Interroll. They are the same as those used for the roller conveyor that transports pallets without being combined with chains. They belong to the heavy-duty conveyor roller conveyor Series 3600. ROLLER CONVEYORS FOR THE PALLETS, or the corresponding document in annex 2.

The structures vary depending on where the roller conveyor is located in the line. In general they are all similar and use the same components. They are just placed differently and their lengths vary from one to another.

All the sensors used are presence sensors, photocells of the company SICK type WL12-3V2431, with article number 1041537. They have been described previously in section 7.4.1. ELECTION OF THE SENSORS. They are fastened with square tubes 25 x 25 x 3 mm and length.

### 15.2.1. FIRST ROLLER CONVEYOR

The first roller conveyor is interspersed with six chains. The roller conveyors have different distances between them, depending on whether it is necessary to leave space for a chain between two of them, where 240 mm or 300 mm are left between the middle chains, as there is more space between them, or when there is no chain, 200 mm of space is left. These measurements are shown in Figure 15.11.

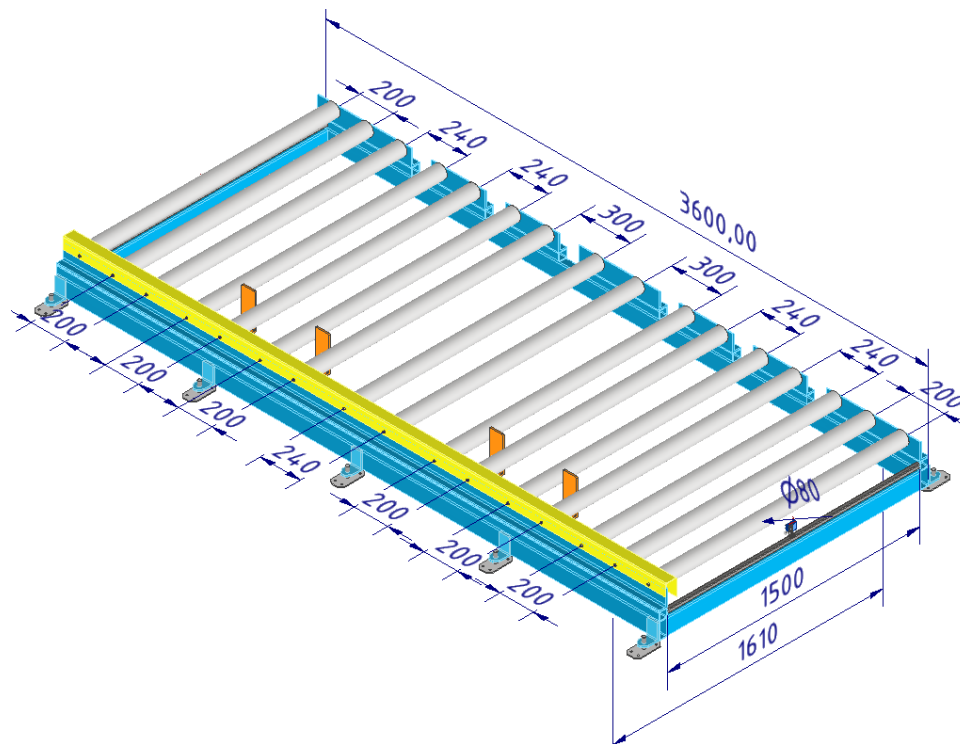

Figure 15.11. First roller conveyor of the chain roller conveyor machine that transports pallets. Dimensions in mm.

The pallets are stopped with fixed stoppers placed perpendicular to the rollers. These stoppers must be placed in the gaps between the chains and the rollers, so the length measured in width is 80 mm, in order not to collide with the rest of the components.

The stoppers are fastened to the longitudinal tubes just below the structure into which the roller axles are inserted with screws.

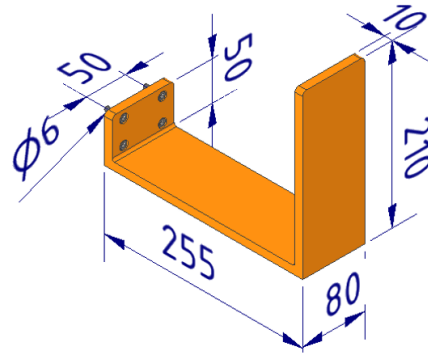

Figure 15.12. Still stoppers for the pallets in the first roller conveyor. Dimensions in mm.

There are three sensors: one on the right, which should never detect material there; if it does, there is a problem. Another in the middle, which detects when the pallets have started to move, as it is located between the two flows of the chain conveyor. Finally, there is a sensor at the exit of the roller conveyor that detects when the material leaves the line.

### 15.2.2 SECOND ROLLER CONVEYOR

The second roller conveyor only handles one flow of pallets, so it is shorter than the previous one. The structure is exactly the same, only the dimensions change.

In this case, the stopper is positioned to stop the pallets coming through the roller conveyor, so it is parallel to them. It is a fixed stopper, since the pallets will never follow a straight path, but must change direction along the chain conveyor. This stopper is

shown in Figure 15.13 together with the rectangular tube DIN EN 20210-2 80 x 50 x 4 mm and 1500 mm long on which it is fastened with DIN 6912 M10 x 20 mm bolts.

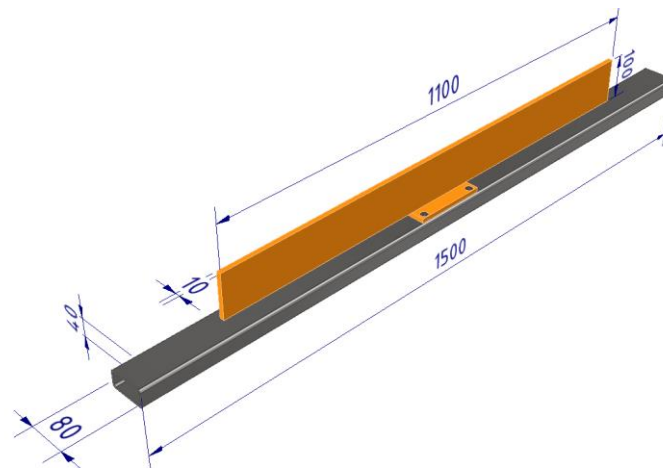

Figure 15.13. Still stopper in the roller conveyor part of the chain roller conveyor that transports pallets. Dimensions in mm.

As this is a shorter machine, the four sensors are arranged two on square tubes DIN EN 20210-2 25 x 25 x 3 mm, so that their function is twofold: the first two, on the same tube, detect when the pallet enters first, the next two when the pallet is in position to lift the chain conveyor. Then, when the pallet starts to be moved by the chain conveyor, two sensors on different tubes are the first to stop detecting the pallet, which means that the pallet is in movement leaving the roller conveyor. An image of this machine with its measurements is shown in Figure 15.14.

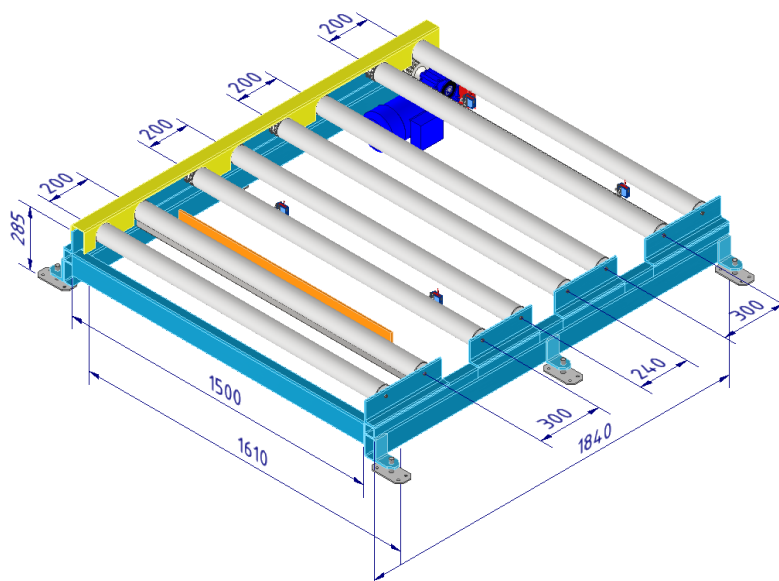

Figure 15.14. Second roller conveyor of the chain roller conveyor machine that transports pallets. Dimensions in mm.

### 15.2.3. THIRD ROLLER CONVEYOR

The third roller conveyor is very similar to the second roller conveyor explained in section 15.2.2 *SECOND ROLLER CONVEYOR* as if reflected in a mirror, as the chains enter from the opposite side. In addition, it has a longer side to connect this roller conveyor with the next machine. Here, too, the fixed stopper is located at the end of the chain path.

The sensors have been placed in the same way as in the second roller conveyor, plus two larger ones, located on the extension of the roller conveyor to know where the pallet is in the machine at all times and when it leaves it.

The structure of this roller conveyor with its dimensions can be seen in Figure 15.15.

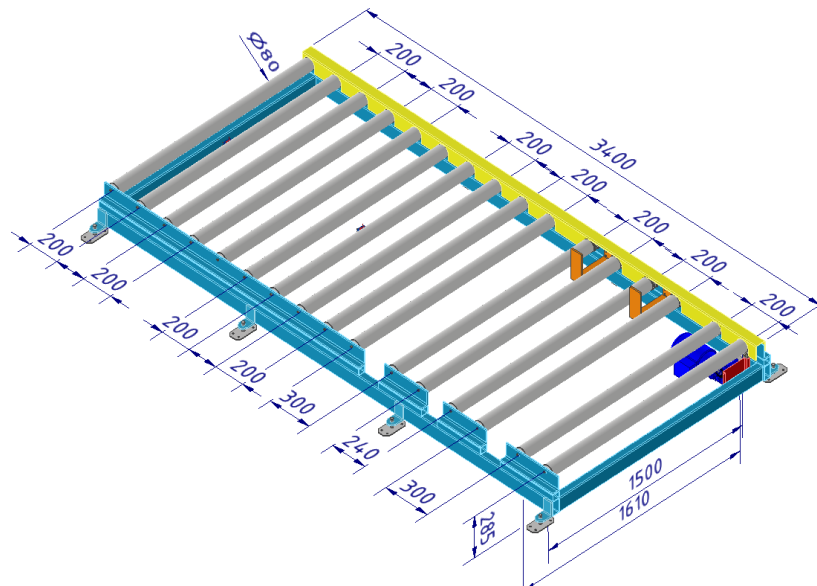

Figure 15.15. Second roller conveyor of the chain roller conveyor machine that transports pallets. Dimensions in mm.

### 15.2.4. FOURTH ROLLER CONVEYOR

This roller conveyor resembles the first one as if it were its reflection in a mirror. The only change is the position of the stoppers. There is a fixed stopper to stop a pallet at the end of the roller conveyor, similar to the one on the second roller conveyor, and another one in the middle, just after passing over the first chain conveyor, but this one is mobile. It rests on a cylinder in the same way as the stopper on the chain conveyor in



the lifting table, section 8.2. *LIFTING TABLE*. In Figure 15.16 you can see this stopper with its dimensions.

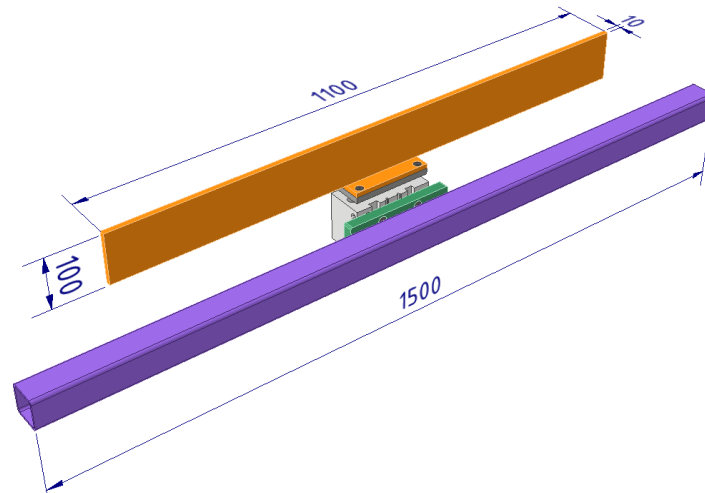

Figure 15.16. Moving stopper of the fourth chain roller conveyor.

The sensors are placed at the beginning, middle and end of the roller conveyor. There are four on the chain conveyor, two for each pallet flow, to detect when there is a pallet and when it leaves the machine.

## 16. LINE PROTECTION FENCES

The process does not require human intervention at any time. In fact, it would be dangerous for any employee to interfere with the production line due to the continuous movement of machinery which could trigger an accident.

To avoid unnecessary occurrences, a protective fence has been placed along the entire length of the line. The single panel forming a part of the fence has been created with DIN EN 10210-2 25 x 25 x 2.5 mm elements, and the grid between the rectangular tubes has been created with the part file and the feature the create a pattern. The result can be seen with its dimensions in Figure 16.1.

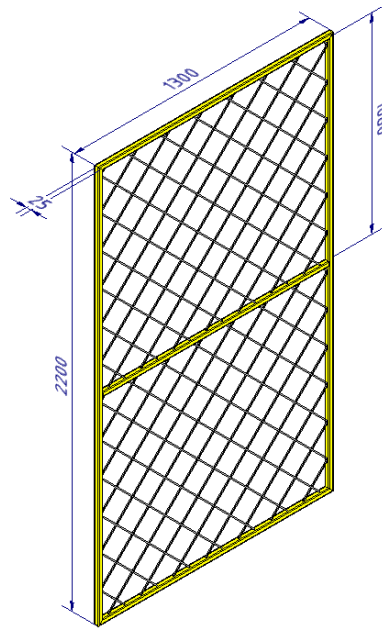

Figure 16.1. Elementary panel that forms the structure of the surrounding protection fences.  
Dimensions in mm.

The panels are supported by square frames DIN EN 10210-2 50 X 50 X 3 mm, 2200 mm long. They are supported on a 180 x 180 x 10 mm flat surface with four holes to anchor them to the floor. In order to prevent this tube from tilting, apart from releasing it, four pieces have been placed to join it to the plane that rests on the floor in order to reinforce the joint. Some pieces have been built to hold the panels. On the lower part, the pieces have a horizontal part on which the panels rest, and then a vertical part where there are two holes in which DIN EN ISO 1207 M6 x 8 mm screws are inserted to hold them in place. In the upper part, the parts are only anchored vertically. An example of this structure can be seen in Figure 16.2 below.

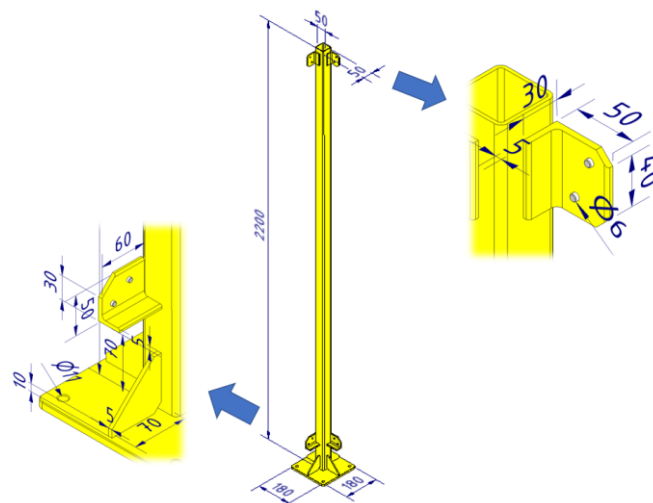
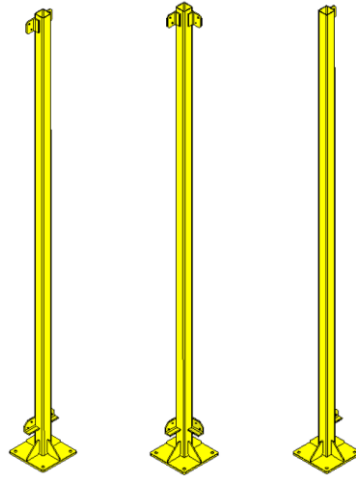

Figure 16.2. Vertical structure that holds the fences surrounding the line with zoom in the joining pieces. Dimensions in mm.

There are three types of these structures: those that are in a corner, such as the one in Figure 16.3, those that end on one side, or those that join panels in a straight line. This can be seen in Figure 16.3.



*Figure 16.3. Different standing structures to hold the pallets. On the left, it holds to panels in the same plane. In the middle, it is situated in a corner. On the right, it is situated in the end of a row. Dimensions in mm.*

The way in which this structure is distributed has been done taking into account that a distance between half a metre and one metre should be left, except for the robots that need two metres around them so as not to interfere with their working area. An image of the entire fence surrounding the production line can be seen in Figure 16.4.

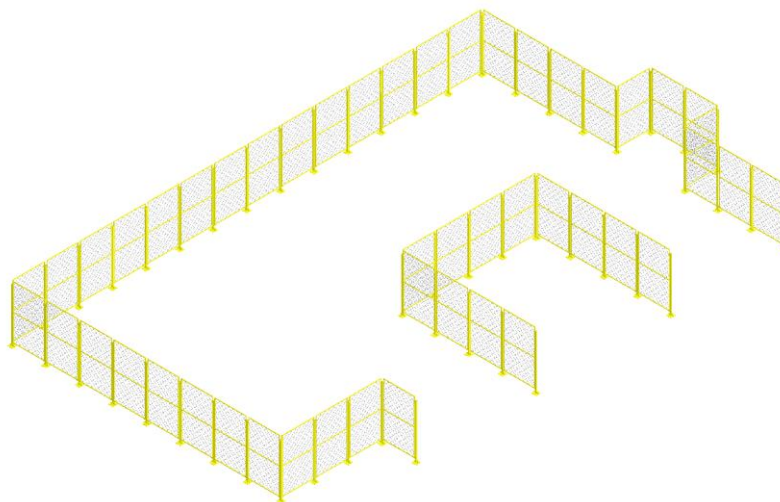

*Figure 16.4. General view of the surrounding protection fences in the production line.*

## REFERENCES

- ABB Group. (n.d.) *About ABB*. Retrieved May 2021 from <https://global.abb/group/en/about>
- ABB. (n.d.). *IRB 760 Industrial Robot*. Retrieved April 2021 from <https://new.abb.com/products/robotics/industrial-robots/irb-760>
- Autodesk Help (2021, April 21<sup>st</sup>). *File Types and Templates in Inventor*.  
<https://knowledge.autodesk.com/support/inventor/learn-explore/caas/CloudHelp/cloudhelp/2020/ENU/Inventor-Help/files/GUID-94B779C0-6B2B-499A-A4F9-2E4BAB49712F-htm.html>
- Autodesk Inventor 2021. (n.d.). Welcome to Inventor Help. Retrieved March 2021 from <https://help.autodesk.com/view/INVNTOR/2021/ENU/>
- Castaño, J. (2019). *El mercado del mueble en Polonia*.  
[http://www.exportapymes.com/documentos/productos/le2981\\_polonia\\_mueble.pdf](http://www.exportapymes.com/documentos/productos/le2981_polonia_mueble.pdf)
- Costa Levigatrizi. (n.d.). *Costa Levigatrizi*. Retrieved April 2021 from <http://www.costalev.com/>
- Costa Rican logistics committee - "CCL". (November, 2003). *Manual de logística de la paletización*. [https://www.gs1cr.org/wp-content/uploads/2016/04/manual\\_logistica.pdf](https://www.gs1cr.org/wp-content/uploads/2016/04/manual_logistica.pdf)
- Cross + Morse. (2010). *Timing Belt Catalogue*.  
<https://feyc.eu/download/catalogos/transmision/morse/Timing%20Belt%20Online%20Catalogue-2010.pdf>
- DAGAR. (n.d.). Chain guides Type 2. Retrieved May 2021, from <https://www.dagar.eu/oferta,typ-t2,67.html>
- FAMAD. (n.d.). *SCISSORS LIFT DBNA*. Retrieved May 2021, from <http://www.famad.com.pl/en/offer/devices/11-xi-Lifts/59-podnosnik-nozycowy-dbna>
- Fluder. M. (n.d.). *About company*. Retrieved April 2021 from <http://www.famad.com.pl/en/famad/about-company>
- HIWIN. (2019). *Linear Guideway. Technical Information*.  
[https://www.hiwin.com/pdf/linear\\_guideways.pdf](https://www.hiwin.com/pdf/linear_guideways.pdf)

- HIWIN. (n.d.). *Configure Product HG Series – Block*. Retrieved May 2021 from <https://motioncontrolsystems.hiwin.com/configurator/hg-series-block>
- MÄDLER GmbH (2020, February). *MÄDLER GmbH*.  
[https://www.maedler.de/files/Firmenprofil\\_Maedler\\_EN.pdf](https://www.maedler.de/files/Firmenprofil_Maedler_EN.pdf)
- Metalmecánica Fácil. (n.d.). *Cálculo de las RPM en las Máquinas Herramientas*. Retrieved May 2021 from <https://metalmecanica-facil.mahtg.com/calculo-de-las-rpm-maquinas-herramientas/>
- Mitchel, J (n.d.). *Tipos de software CAD*. Retrieved May 2021 from [https://techlandia.com/tipos-software-lista\\_87511/](https://techlandia.com/tipos-software-lista_87511/)
- NKE (2021, May 7<sup>th</sup>). *Autodesk Inventor: qué es y sus ventajas*. NKE CAD system.  
<https://www.nke360.es/autodesk-inventor-que-es-y-ventajas/>
- Nord Drivesystems. (2016). *NORD DRIVESYSTEMS – The company*.  
[https://www.nord.com/media/documents/bw/i8160\\_imagebrochure\\_en\\_3617\\_screen.pdf](https://www.nord.com/media/documents/bw/i8160_imagebrochure_en_3617_screen.pdf)
- NORD Drivesystems. (2020). *FLEXBLOC™ & MINICASE® WORM DRIVES SI & SMI Gear Motors & Speed Reducers*.  
[https://www.nord.com/media/documents/us\\_g1035\\_minicase\\_flexbloc\\_2719.pdf](https://www.nord.com/media/documents/us_g1035_minicase_flexbloc_2719.pdf)
- NORD Drivesystems. (2021). *G1035 Universal Worm gear units SI and SMI*.  
[https://www.nord.com/media/documents/bw/g1035\\_ie1\\_ie2\\_ie3\\_en\\_3717.pdf](https://www.nord.com/media/documents/bw/g1035_ie1_ie2_ie3_en_3717.pdf)
- PIAB. (n.d.). *About us*. Retrieved April 2021 from <https://www.piab.com/en-us/inside-piab/about-us/>
- PIAB. (n.d.). *Kenos vacuum gripper – KVG120*. Retrieved April 2021 from <https://www.piab.com/robot-and-cobot-gripping-solutions/kenos-vacuum-gripping-systems/kvg/kenos-vacuum-gripper-kvg120/>
- Redacción Interempresas (2019, October 10<sup>th</sup>). *Hiwin, el segundo mayor fabricante del mundo de tecnología de sistemas y control de movimiento lineal*. Canales Sectoriales.  
<https://www.interempresas.net/Robotica/Articulos/246767-Hiwin-segundo-mayor-fabricante-mundo-tecnologia-sistemas-control-movimiento-lineal.html>
- SEW Eurodrive. (n.d.). *Company & career*. Retrieved April 2021 from <https://www.sew-eurodrive.pl/company/company.html>

SEW Eurodrive. (n.d.). *R series helical gear units*. Retrieved April 2021 from [https://www.sew-eurodrive.pl/products/gear\\_units/standard\\_gear\\_units/helical\\_gear\\_units\\_r/helical\\_gear\\_units\\_r.html](https://www.sew-eurodrive.pl/products/gear_units/standard_gear_units/helical_gear_units_r/helical_gear_units_r.html)

SICK Sensor Intelligence. (n.d.). *About SICK*. Retrieved April 2021, from <https://www.sick.com/pl/en/about-sick/w/about-sick/>

Siemens (n.d.). *Ingeniería asistida por ordenador*. Retrieved May 2021 from <https://www.plm.automation.siemens.com/global/es/our-story/glossary/computer-aided-engineering-cae/13112>

SKF. (n.d.). *Deep groove ball bearings*. Retrieved April 2021 from <https://www.skf.com/group/products/rolling-bearings/ball-bearings/deep-groove-ball-bearings>

SKF. (n.d.). *FYTJ 30 TF Oval flanged ball bearing units*. Retrieved April 2021 from <https://www.skf.com/group/products/mounted-bearings/ball-bearing-units/flanged-ball-bearing-units/productid-FYTJ%2030%20TF?system=metric>

SKF. (n.d.). *O firmie SKF*. Retrieved April 2021, from <https://www.skf.com/pl/organisation/about-skf>

SMC (2019). *Compact Guide Cylinder*. [https://content2.smcetech.com/pdf/MGP-Z-Dd\\_EU.pdf](https://content2.smcetech.com/pdf/MGP-Z-Dd_EU.pdf)

SMC (n.d.). *The milestone that made us grow into market leaders*. Retrieved May 2020 from <https://www.smc.eu/en-eu/company/history>

TECHNIK CNC. (n.d.). *We are a leader in our industry, a company with an established position on the market*. Retrieved April 2021, from <https://technikcnc.pl/content/4-o-nas>

TECHNIK CNC. (n.d.). *Chain wheel 10B-2-z19 (5/8)*. Retrieved April 2021 from <https://technikcnc.pl/kola-lancuchowe-10b-2/1962-kolo-lancuchowe-10b-2-z19-5-8.html>

## BIBLIOGRAPHY

- Bolkowski, S. (2015). *Computer applications in electrical engineering*. Poznan University of Technology Academic Journals. Electrical Engineering.
- Castañón Ruiz, J.L. (2015). *Roscas y cintas transportadoras (Spanish Edition)*. CasBell Editions.
- Cardona Foix, S., Clos Costa, D., (2001). *Teoría de máquinas. (1st Edition)*. Barcelona: UPC Editions.
- Enríquez Avilés, C. R. (2008). *Técnicas de transporte continuo*. National University of engineering UTO.
- Enríquez Harper, G. (2005). *Fundamentals of Electric Motor Control in Industry*. Limusa Editorial.
- Fraille Mora, J. (2016). *Electric machines (8<sup>th</sup> Edition)*. Ibergarceta Publicaciones S.L.
- López Roa, A. (2004). *Transporte mecánico continuo de materiales sólidos a granel (excepto cintas transportadoras)*. Cegal.
- Mazón, J., Miñambres, J.F., Zorroza, M.A., Buigues, G., Valverde, V. (2008). *Guía de autoaprendizaje de máquinas eléctricas*. Prentice Hall.
- Osinski, P. (2014). *Modelling and design of gear pumps with modified tooth profile*. LAP Lambert Academic Publishing.
- Puente Sánchez, J. (1999). *Diseño de un transportador de cadena*. Autonomous University of Nuevo León, Mechanic and electric engineering faculty.



# ANNEX I: DRAWING OF MACHINES DESIGNED WITH AUTODESK INVENTOR 2021

## TABLE OF CONTENTS

1. DOUBLE CHAIN CONVEYOR
2. SINGLE CHAIN CONVEYOR
3. CHAIN CONVEYOR ON LIFTING TABLE
4. ROBOT IRB 760
5. STILL VACUUM GRINDING SYSTEM
6. ROLLER CONVEYOR OF WOODEN SHEETS
7. BELT ROLLER CONVEYOR
8. MOVING VACUUM GRIPPING SYSTEM
9. FIRST ROLLER CHAIN CONVEYOR FOR PALLETS
10. SECOND ROLLER CHAIN CONVEYOR FOR PALLETS
11. THIRD ROLLER CONVEYOR FOR PALLETS
12. FOURTH ROLLER CONVEYOR FOR PALLETS

VIEW1 ( 1 : 15 )

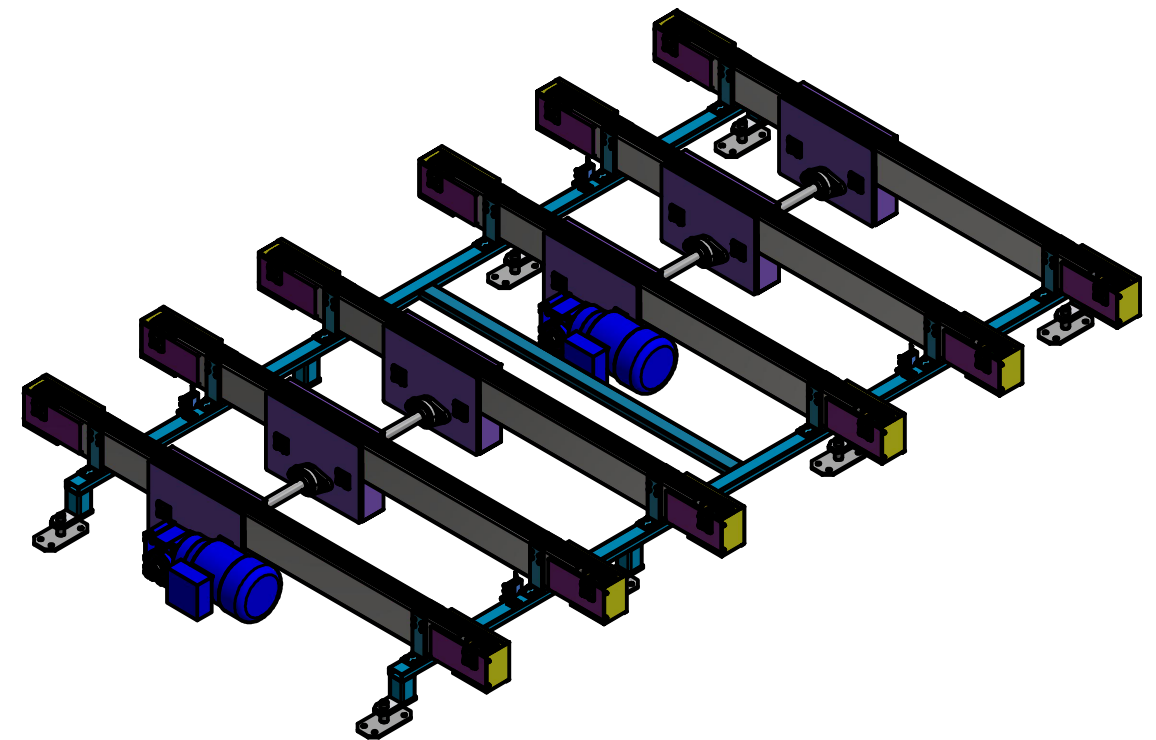
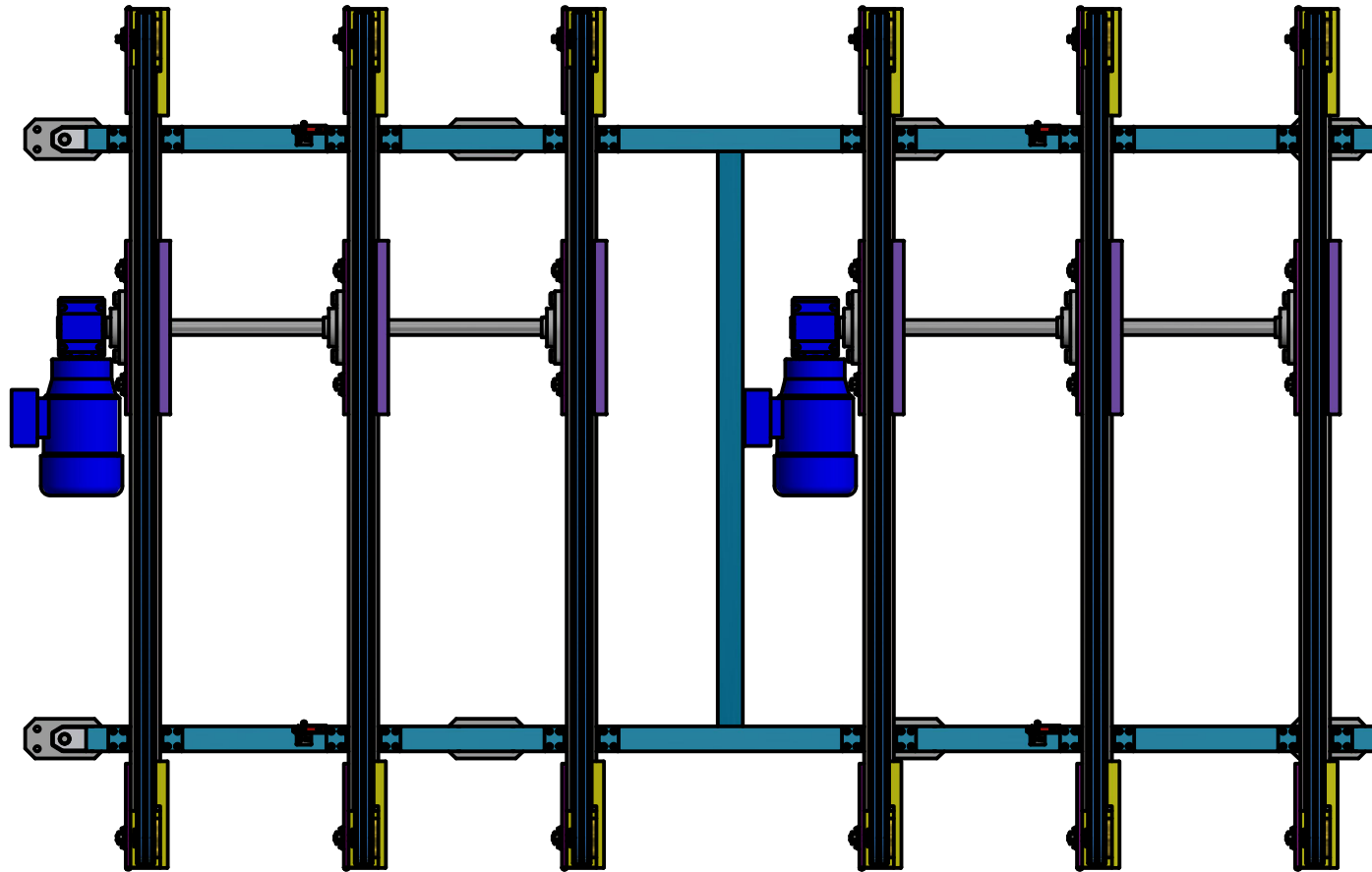
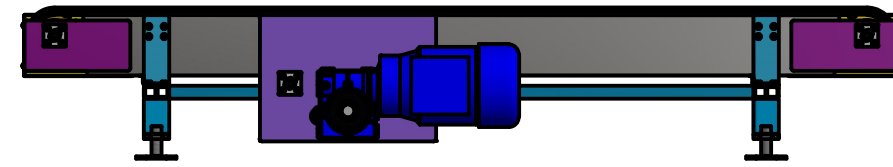
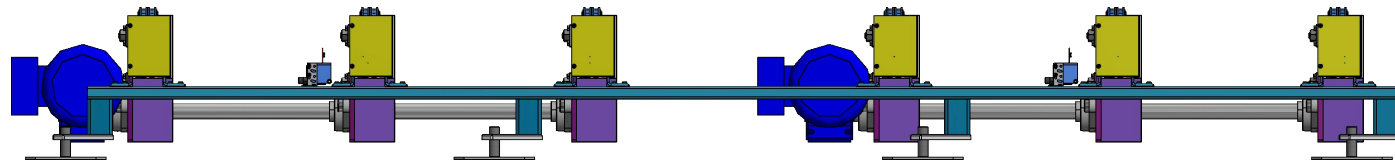

Designed by Alicia García del Amo	Checked by	Approved by	Date	Date 10/06/2021	
			1. DOUBLE CHAIN CONVEYOR		
			Edition	Sheet 1 / 1	

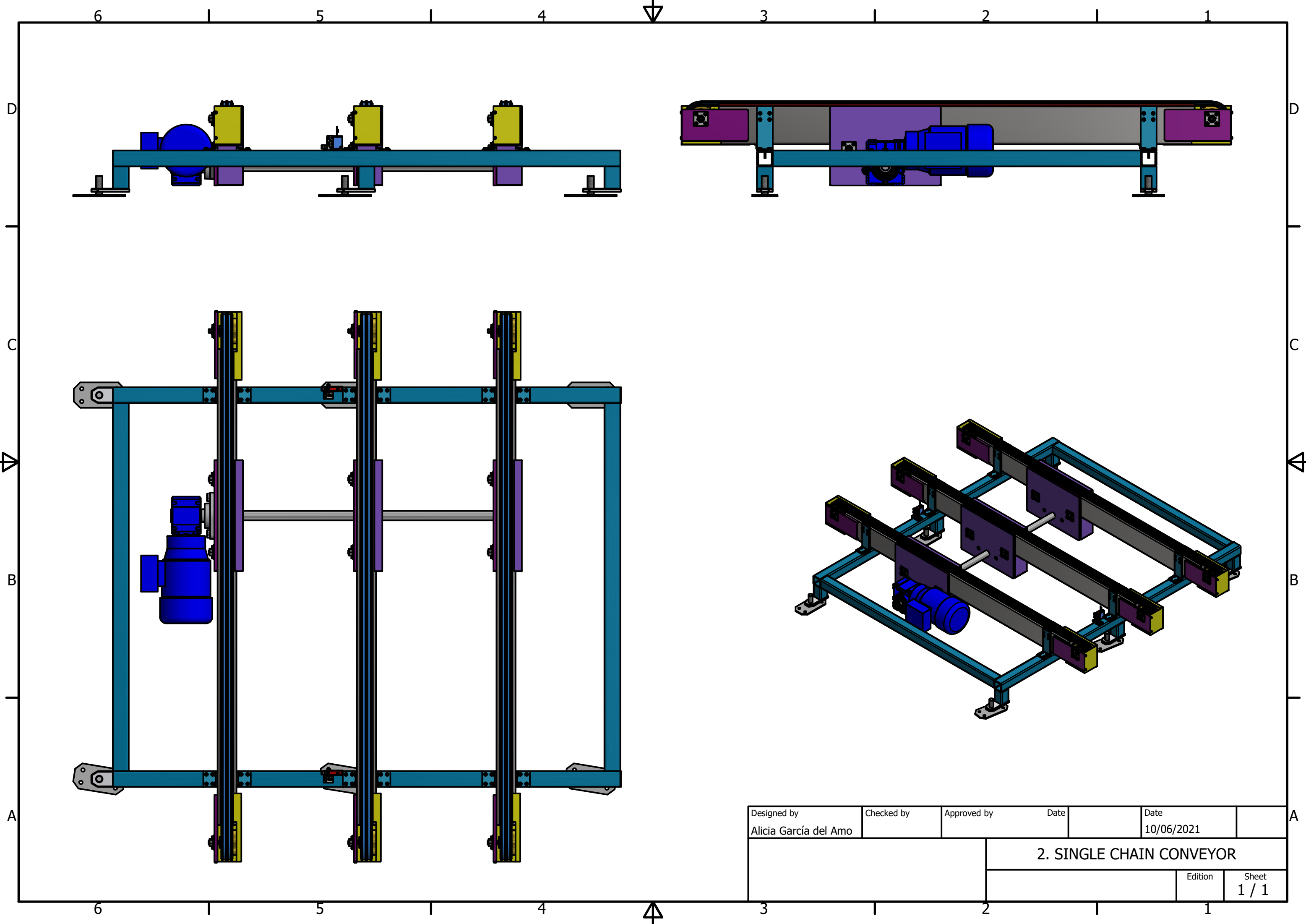

Designed by Alicia García del Amo	Checked by	Approved by	Date	Date 10/06/2021	
			<b>2. SINGLE CHAIN CONVEYOR</b>		
			Edition	Sheet 1 / 1	

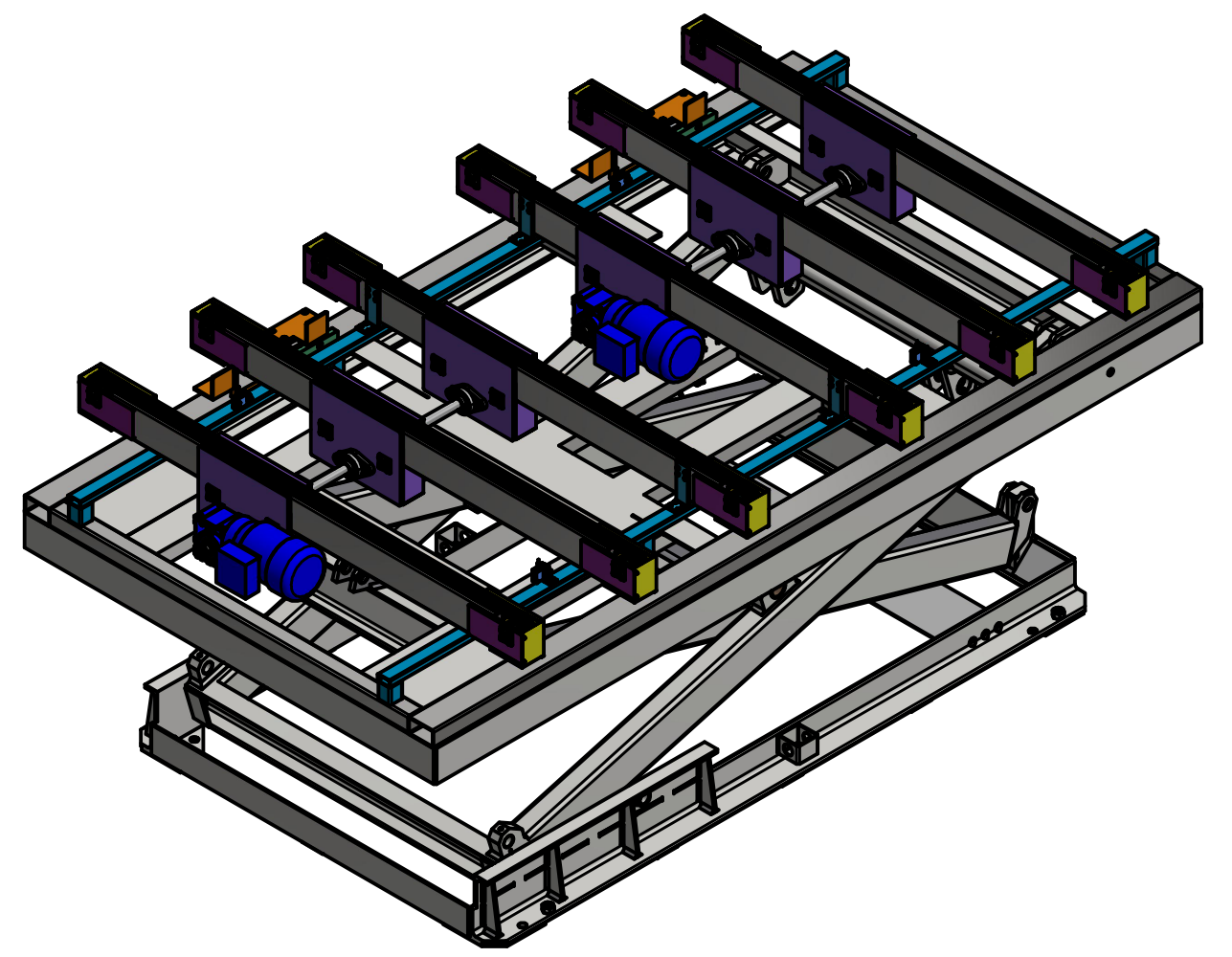
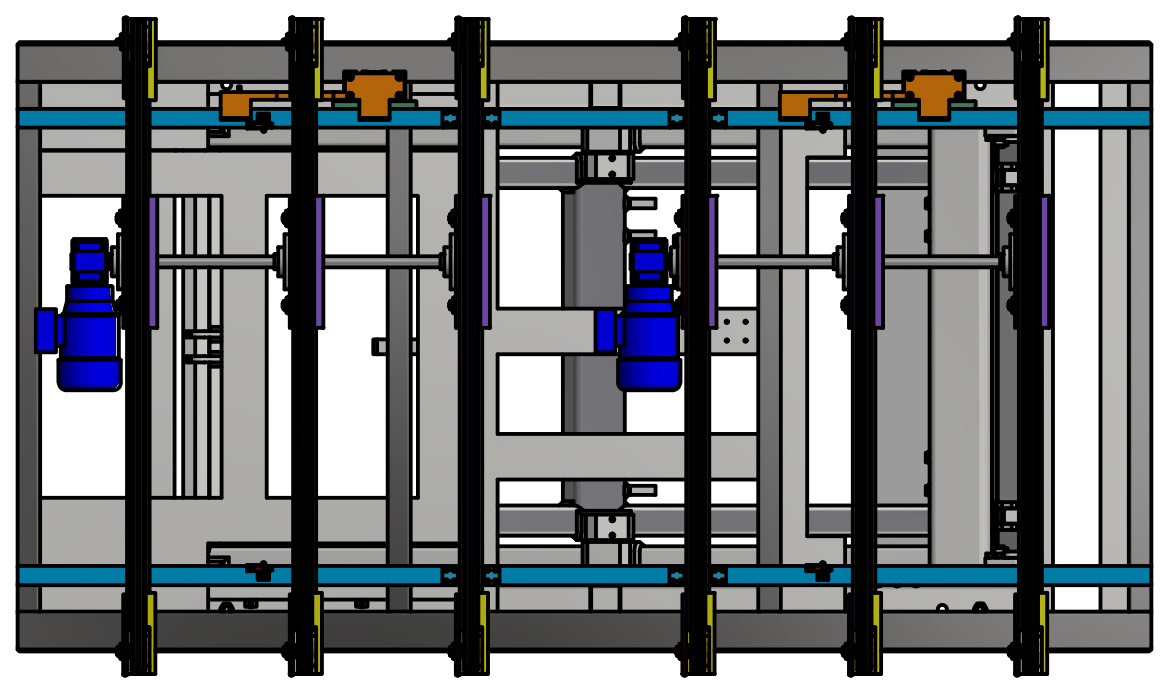
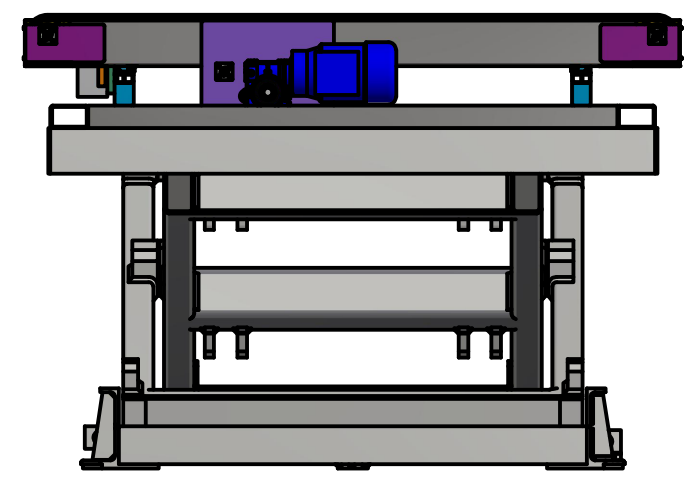
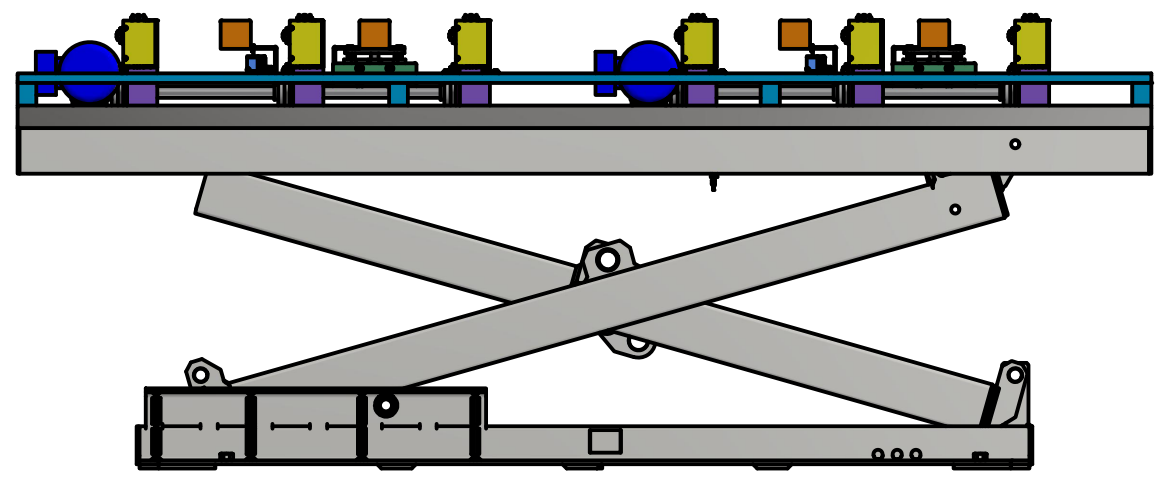

Designed by Alicia García del Amo	Checked by	Approved by	Date	Date 10/06/2021	
			<b>3. CHAIN CONVEYOR ON LIFTING TABLE</b>		
			Edition	Sheet 1 / 1	

VIEW1 ( 1 : 20 )

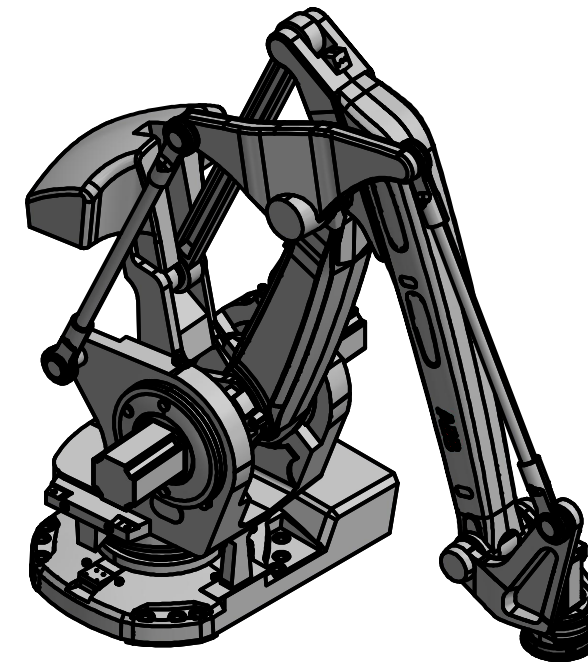
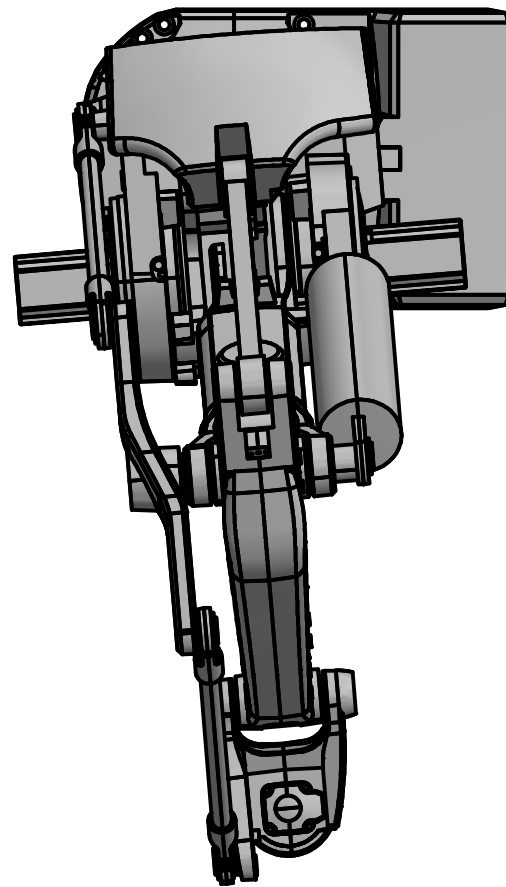
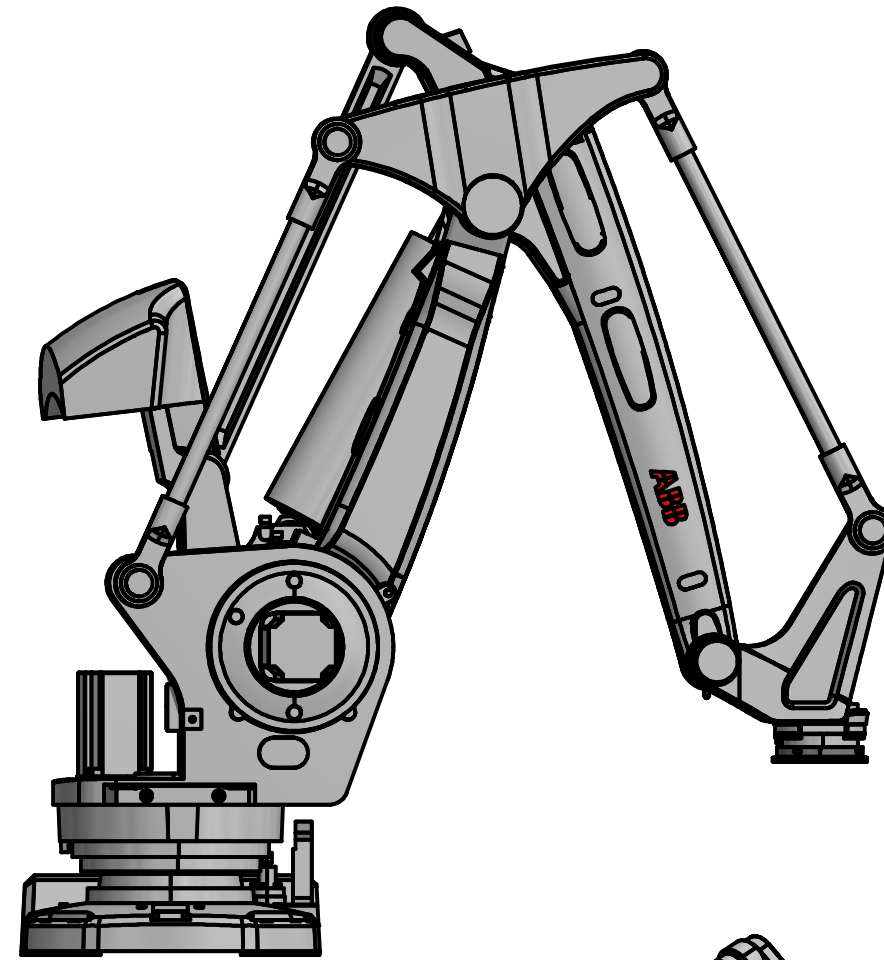
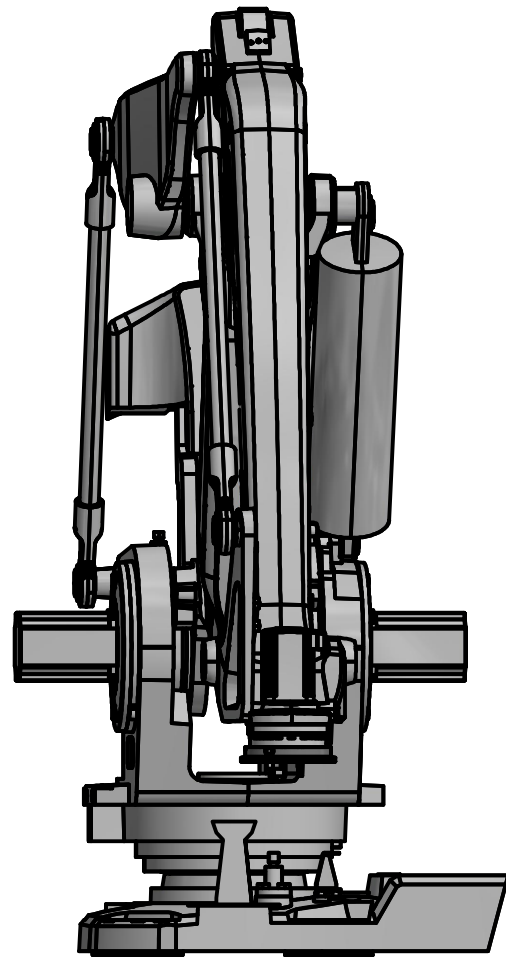

Designed by Alicia García del Amo	Checked by	Approved by	Date	Date 10/06/2021	
			4. ROBOT IRB 760		
			Edition	Sheet 1 / 1	

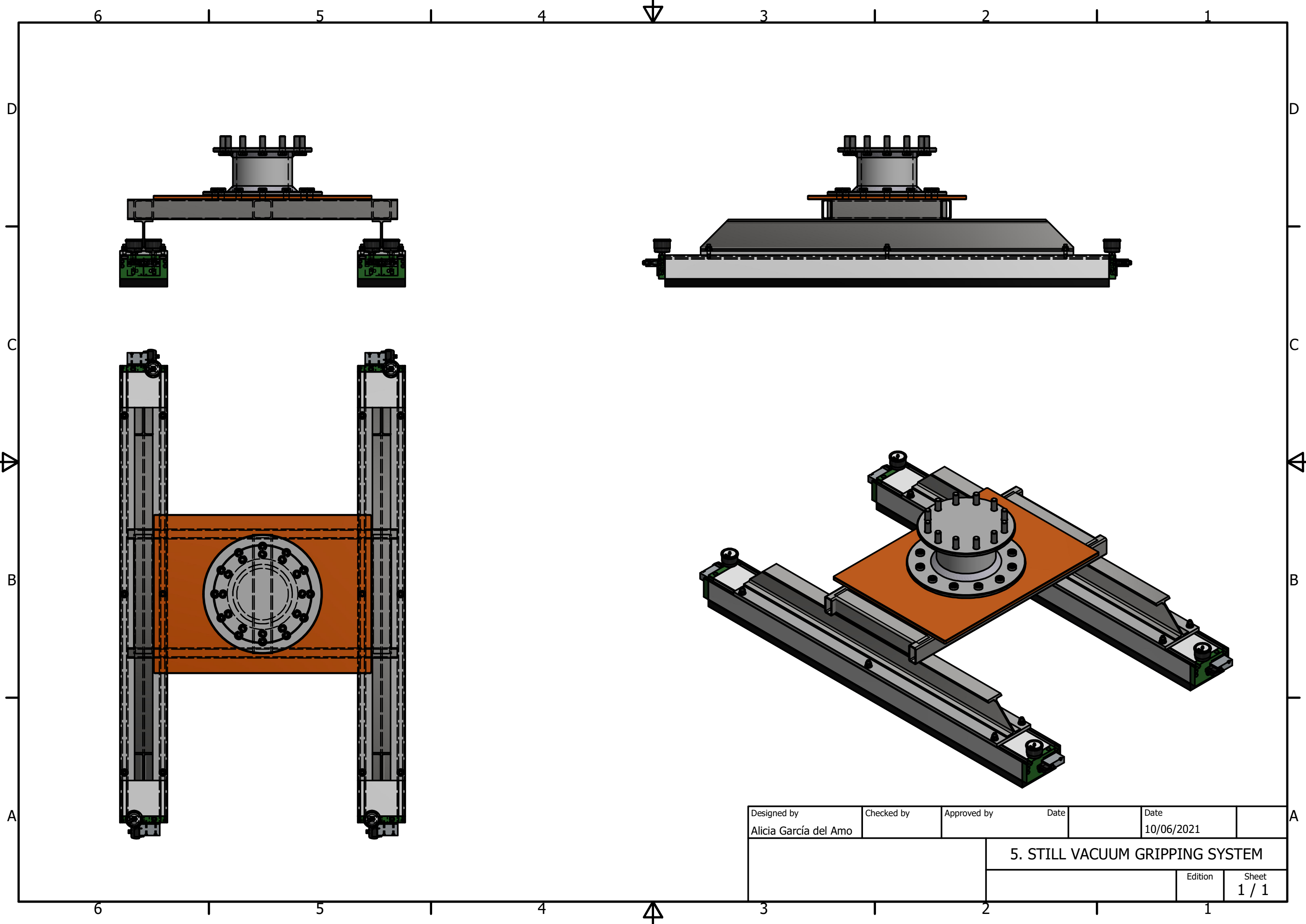

Designed by Alicia García del Amo	Checked by	Approved by	Date	Date 10/06/2021	
			<b>5. STILL VACUUM GRIPPING SYSTEM</b>		
			Edition	Sheet 1 / 1	



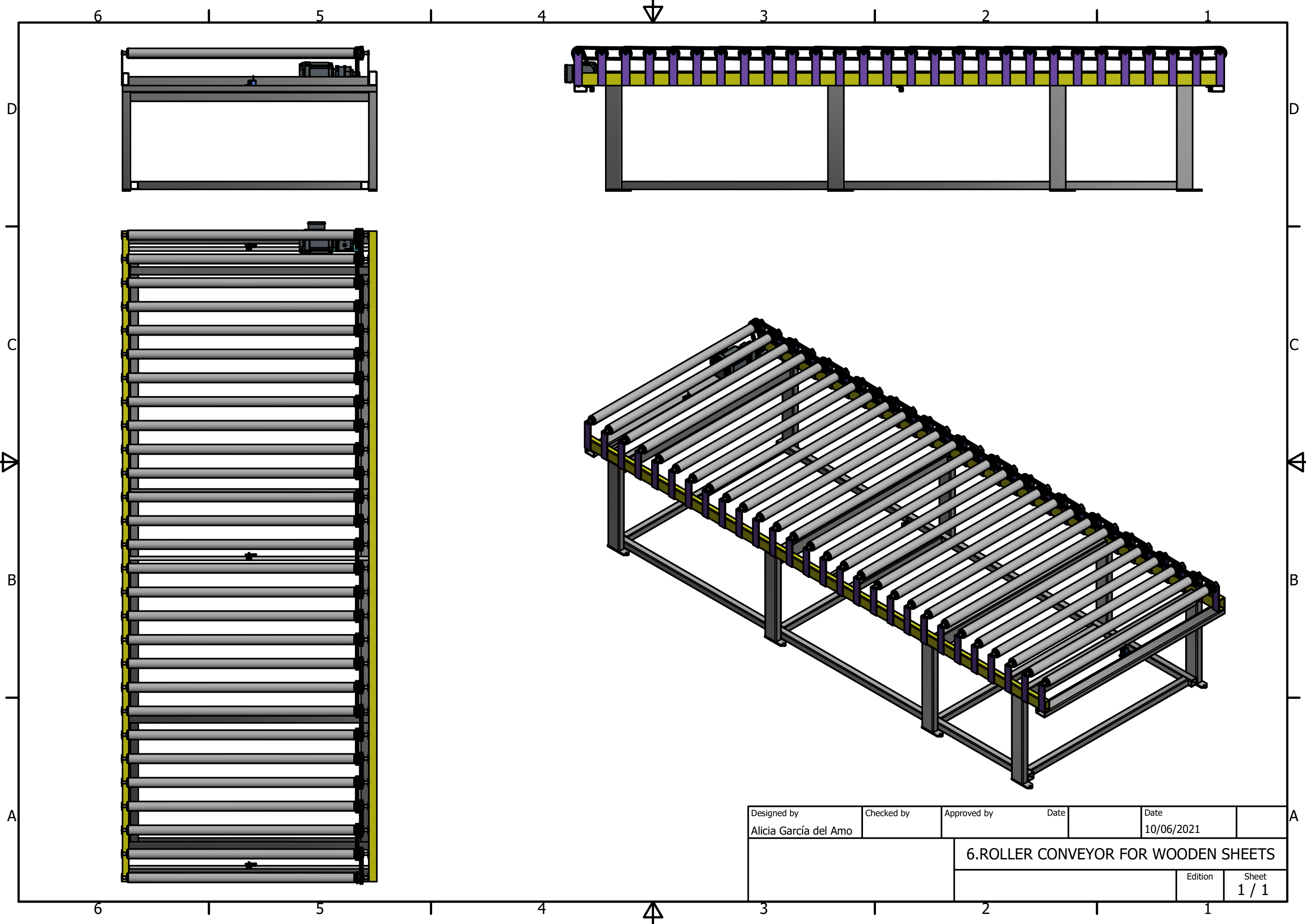

Designed by Alicia García del Amo	Checked by	Approved by	Date 10/06/2021	Date
		<b>6.ROLLER CONVEYOR FOR WOODEN SHEETS</b>		
		Edition	Sheet 1 / 1	

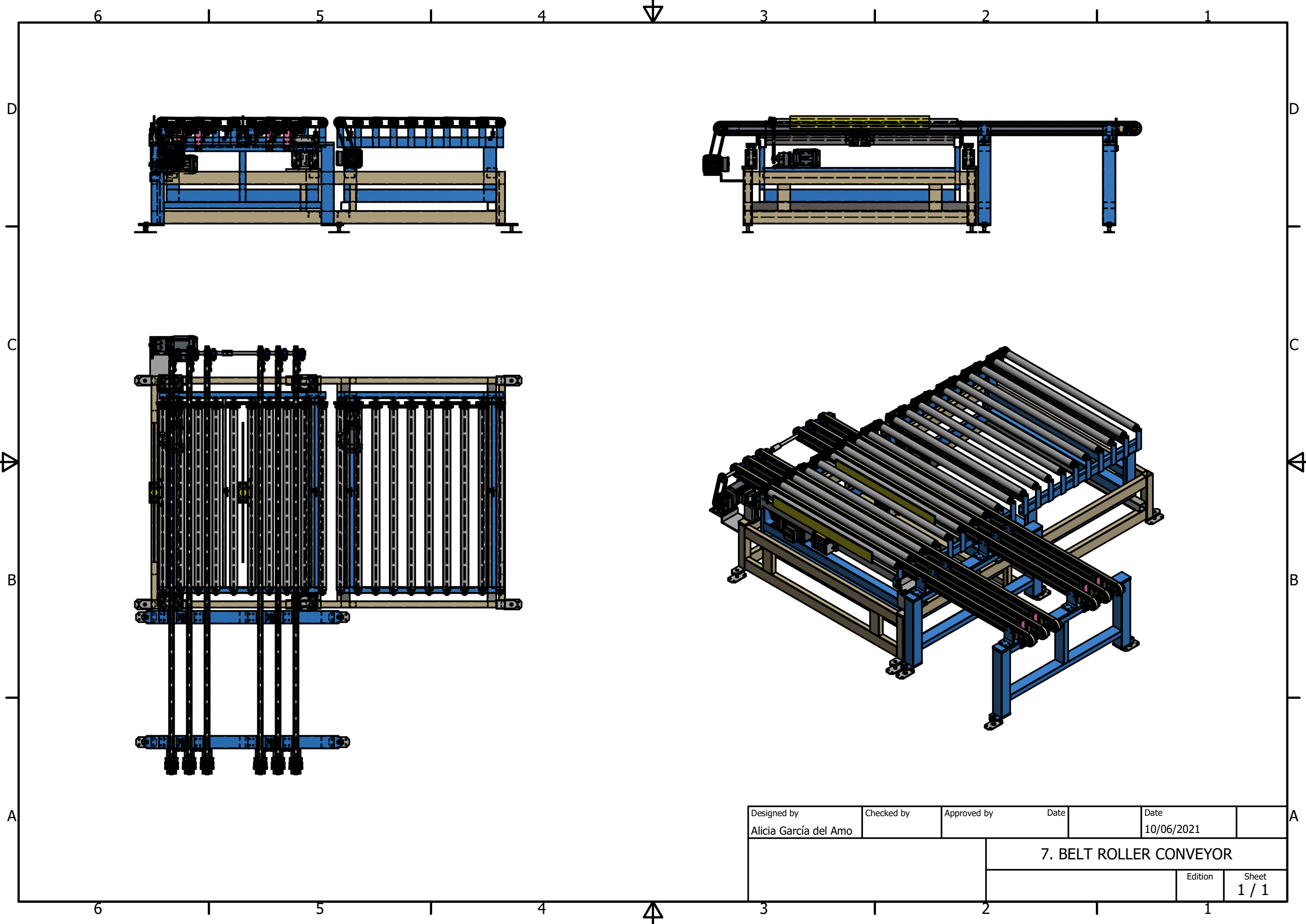

Designed by Alicia García del Amo	Checked by	Approved by	Date	Date 10/06/2021	
			<b>7. BELT ROLLER CONVEYOR</b>		
			Edition	Sheet 1 / 1	

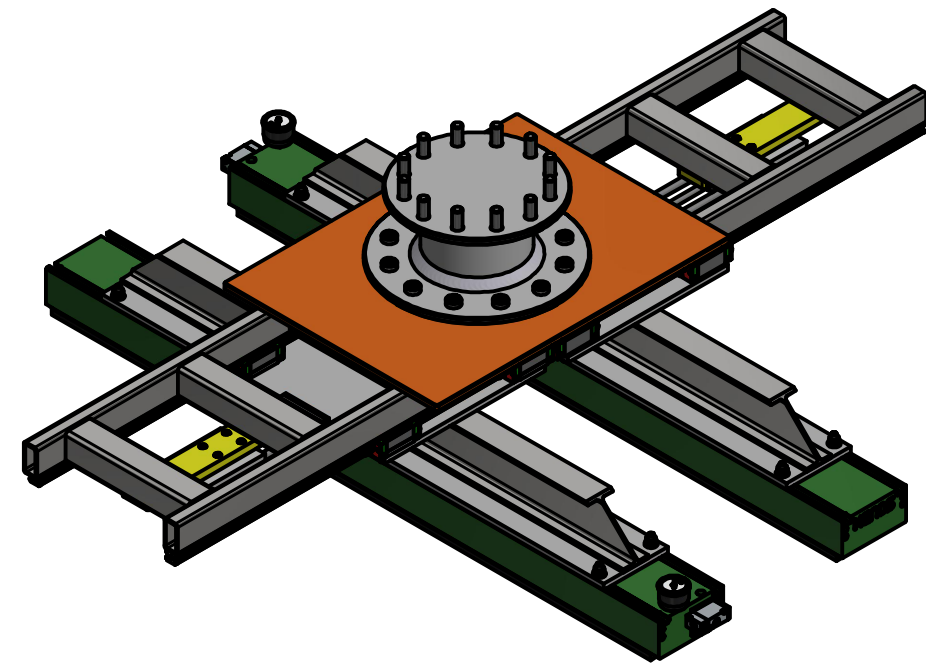
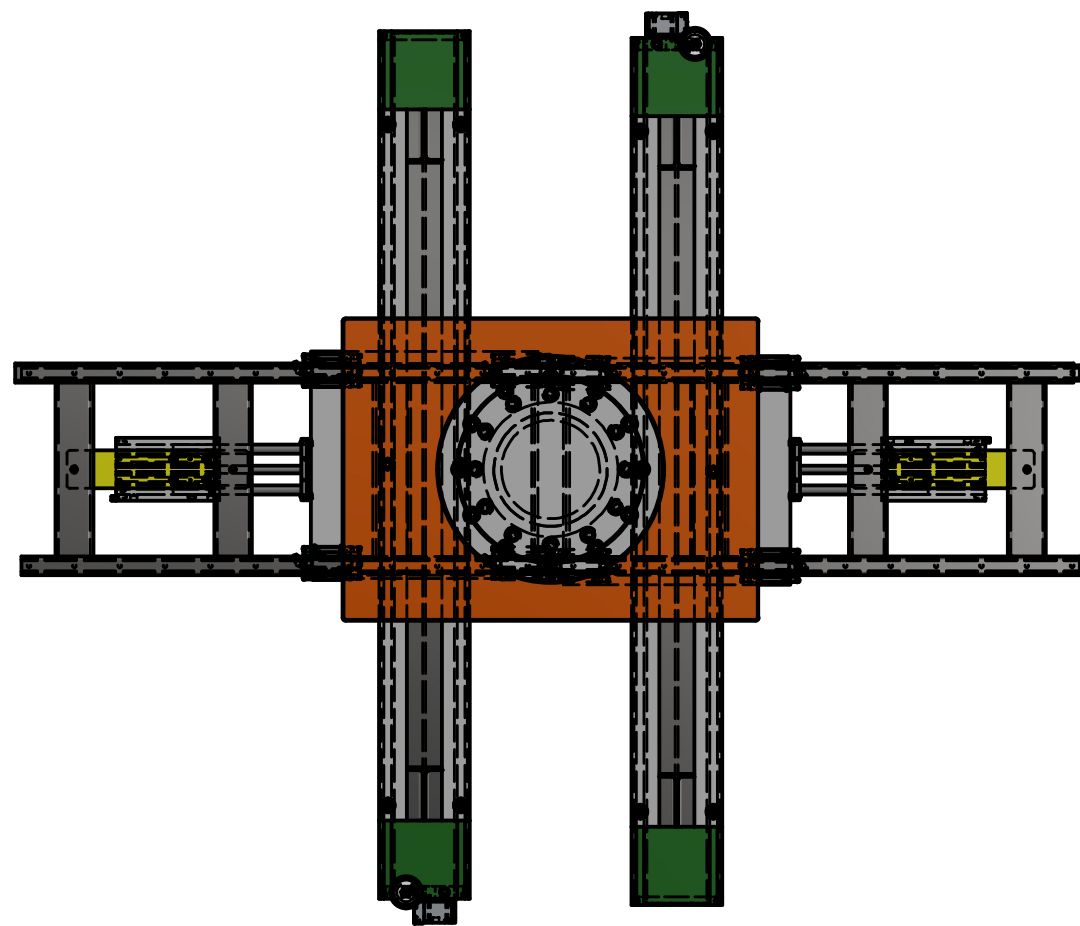
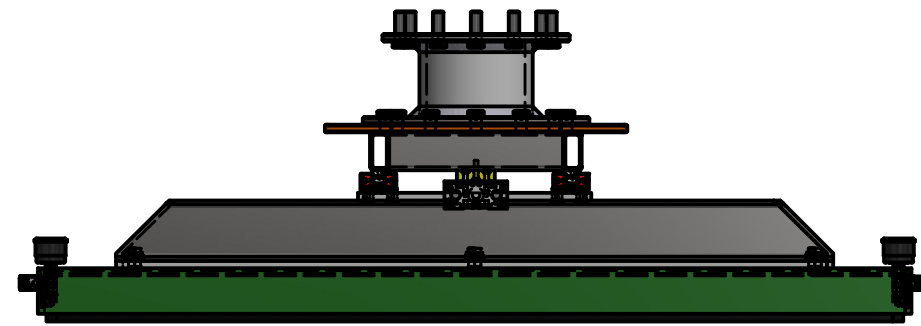
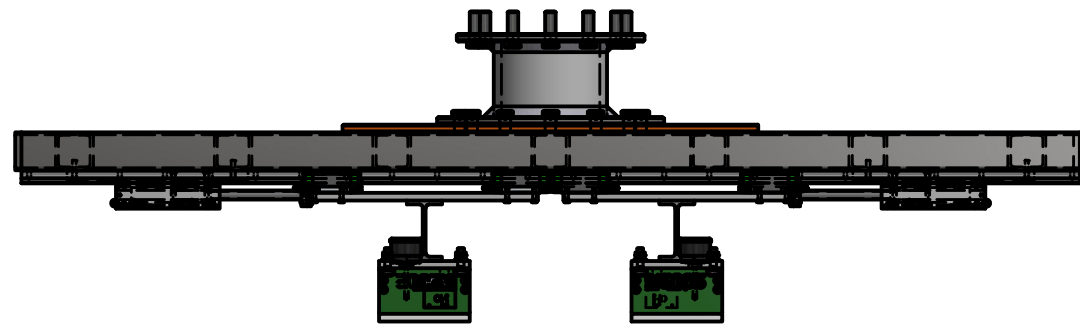

Designed by Alicia García del Amo	Checked by	Approved by	Date	Date 10/06/2021	
			<b>8. MOVING VACUUM GRIPPING SYSTEM</b>		
			Edition	Sheet 1 / 1	

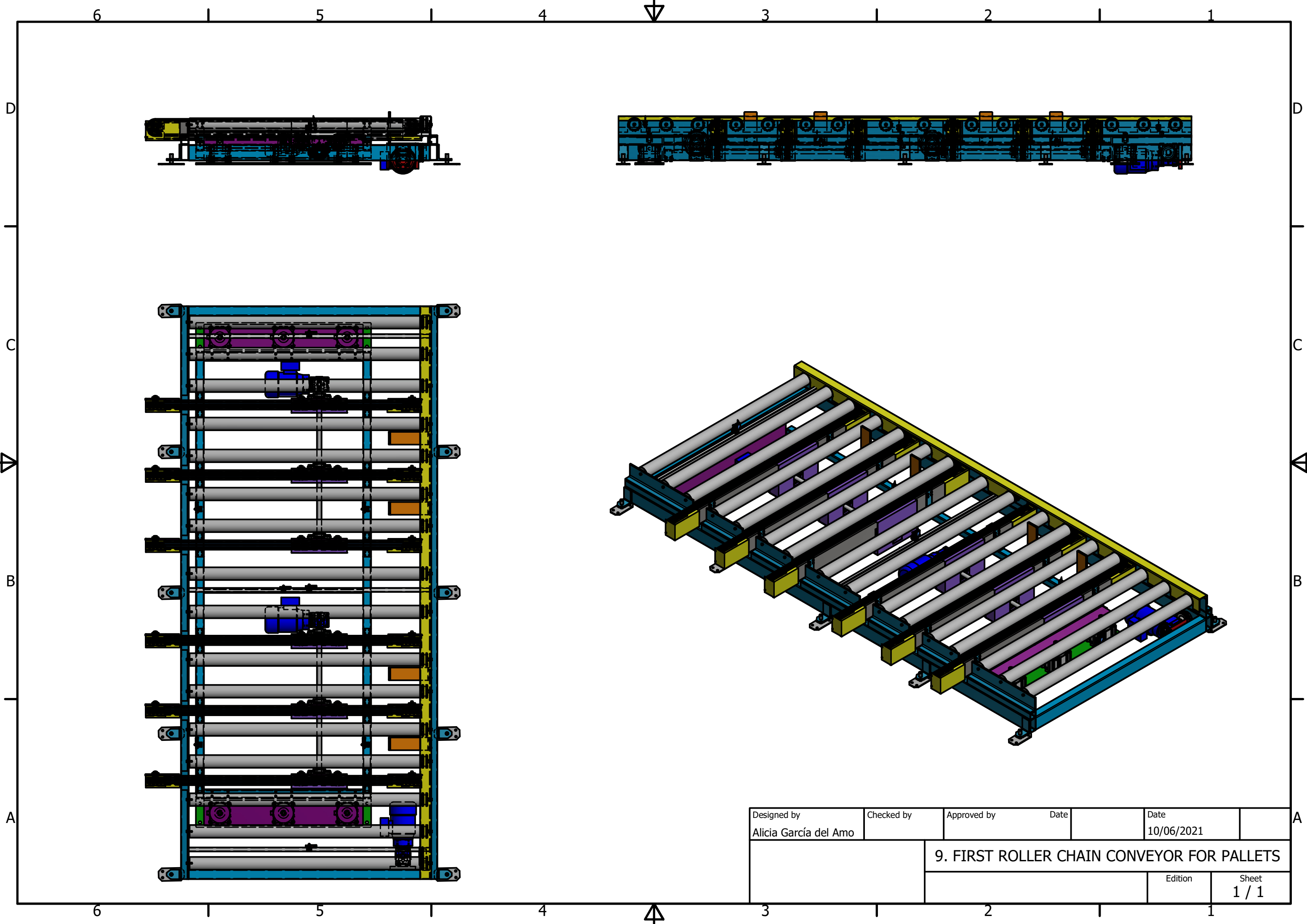

Designed by Alicia García del Amo	Checked by	Approved by	Date	Date 10/06/2021
		<b>9. FIRST ROLLER CHAIN CONVEYOR FOR PALLETS</b>		
			Edition	Sheet 1 / 1



VIEW33 ( 1 : 15 )

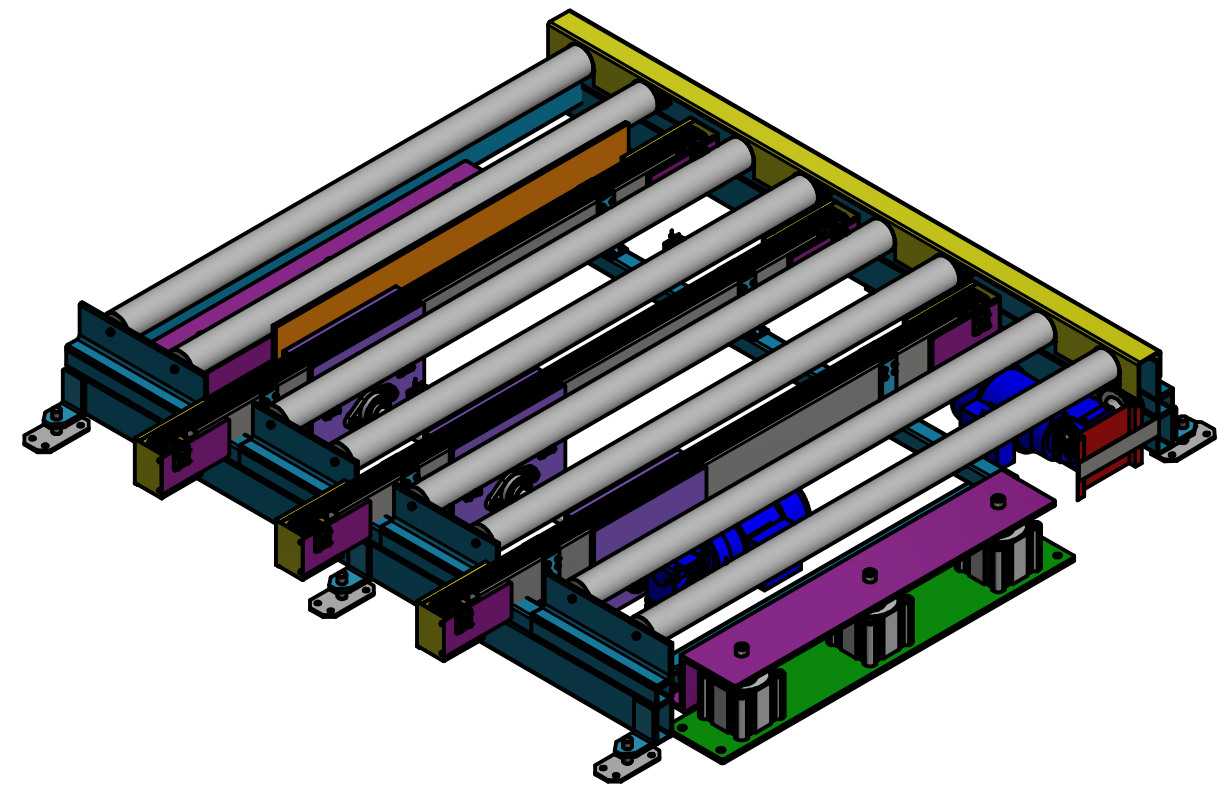
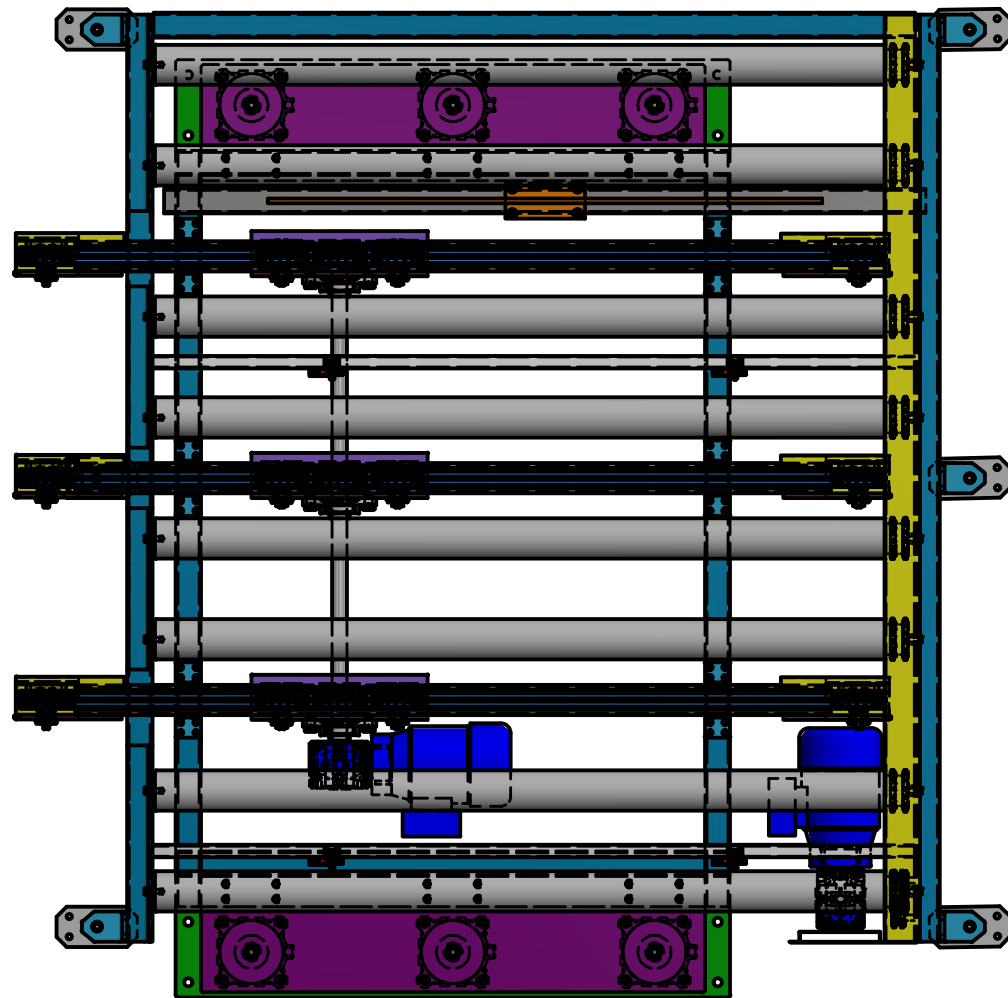
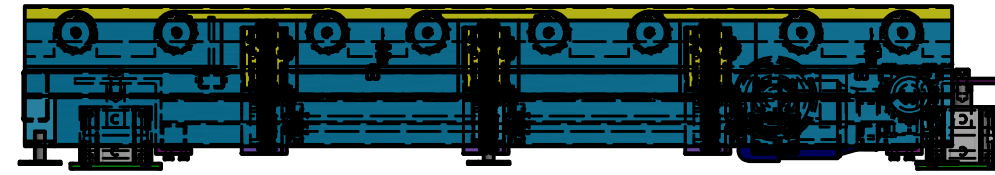
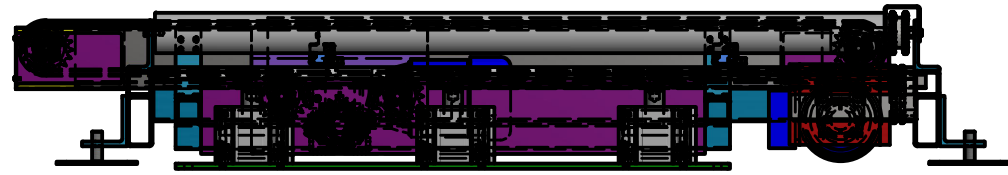

Designed by Alicia García del Amo	Checked by	Approved by	Date	Date 10/06/2021
			10.SECOND ROLLER CHAIN CONVEYOR FOR PALLETS	
			Edition	Sheet 1 / 1

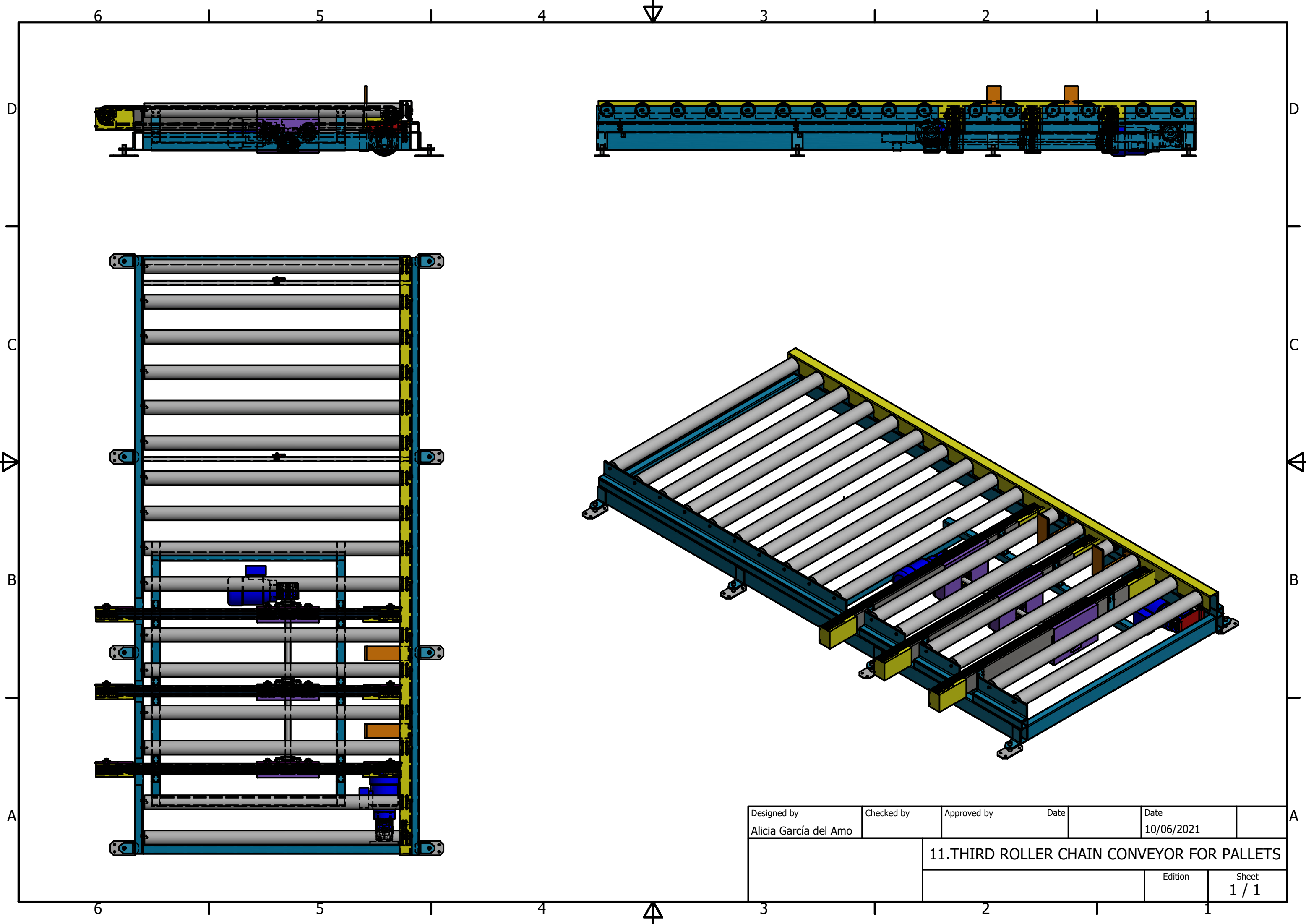

Designed by Alicia García del Amo	Checked by	Approved by	Date	Date 10/06/2021
		11. THIRD ROLLER CHAIN CONVEYOR FOR PALLETS		
			Edition	Sheet 1 / 1

6 1 5 1 4 3 1 2 1 1

D

D

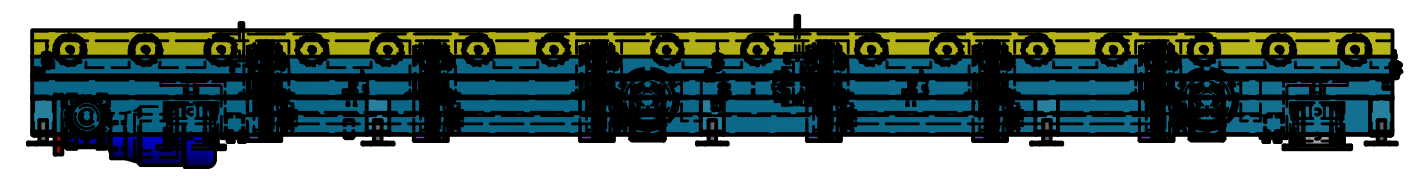
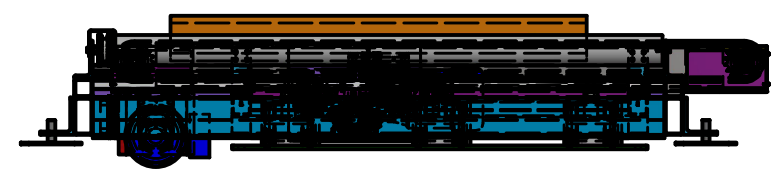

C

C

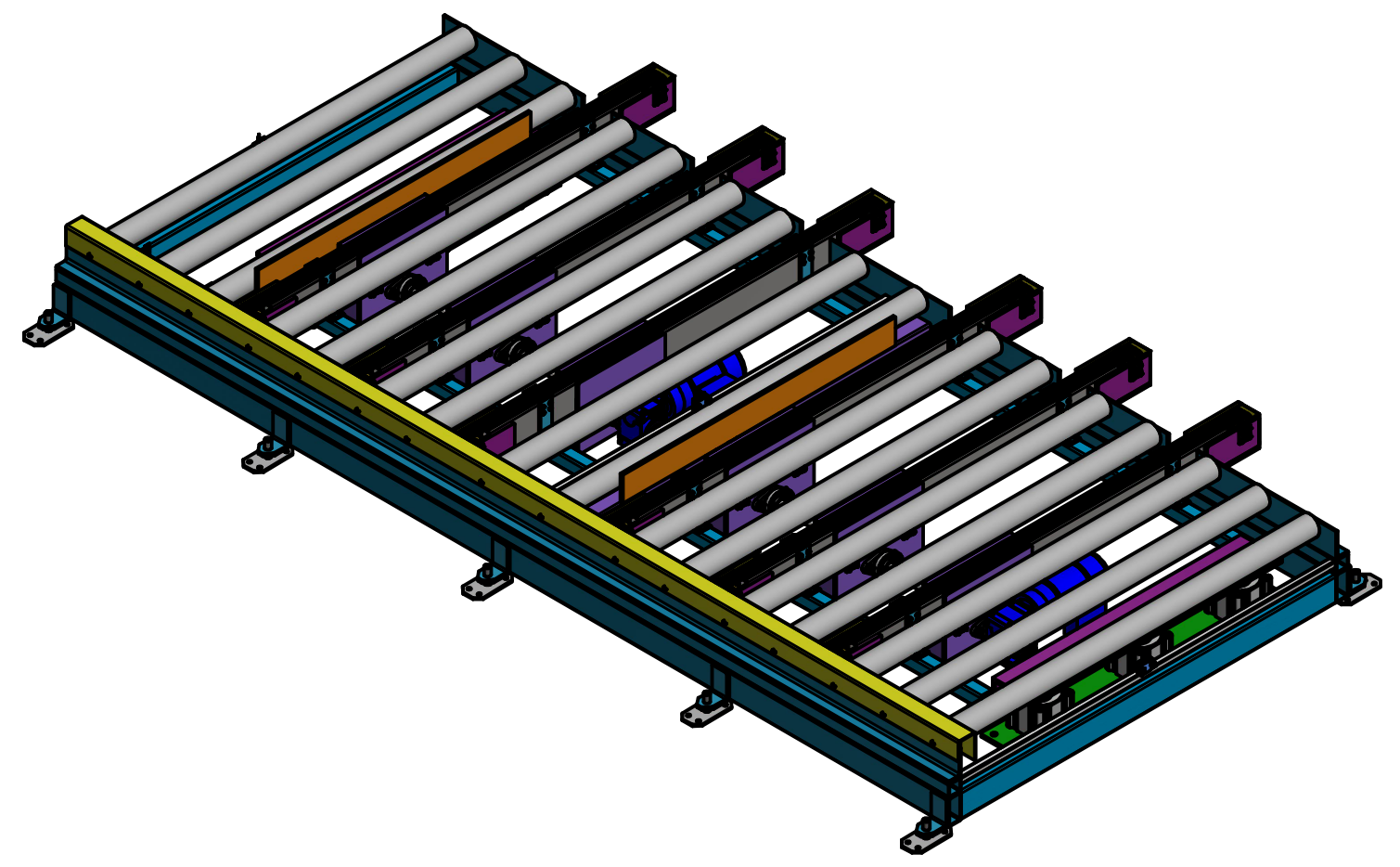
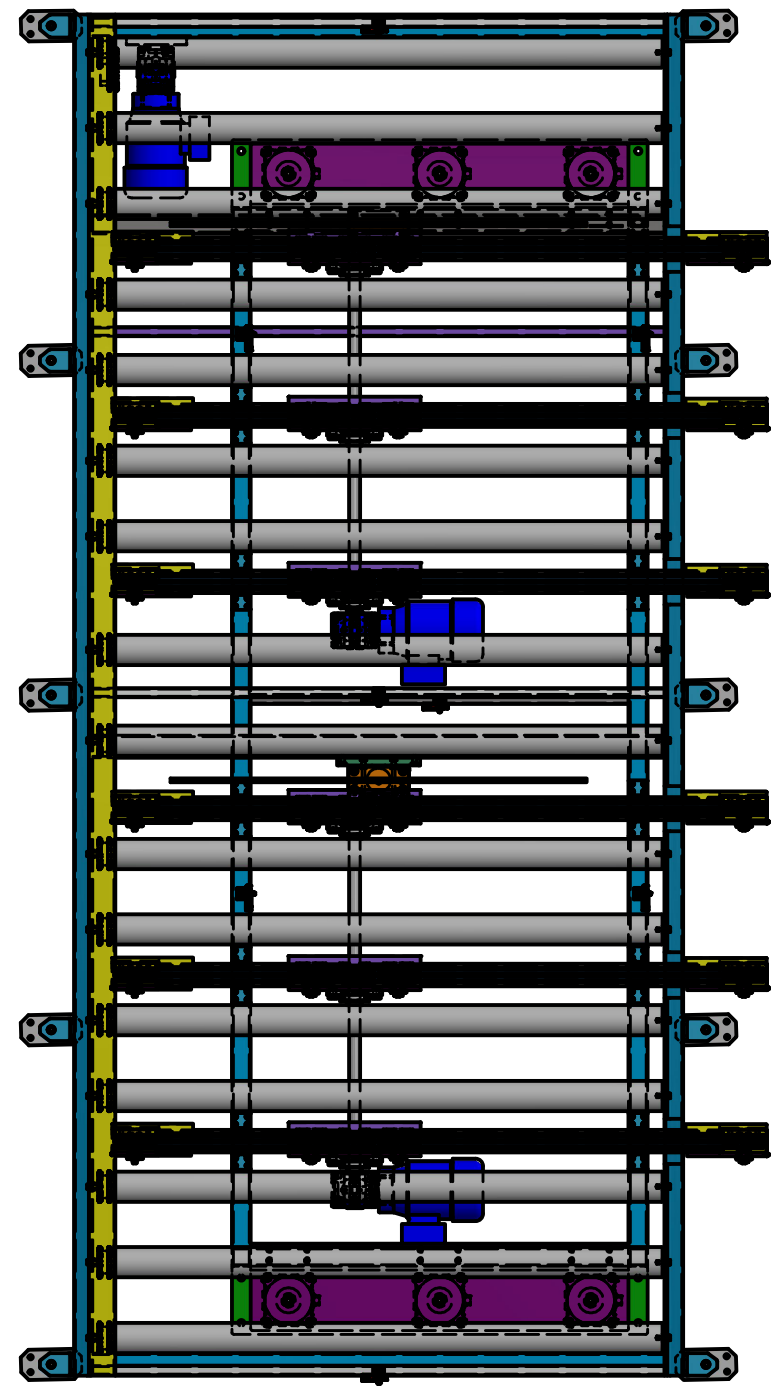

B

B

A

A

A

A

6 1 5 1 4 3 1 2 1 1

Designed by Alicia García del Amo	Checked by	Approved by	Date	Date 10/06/2021
		12.FOURTH ROLLER CHAIN CONVEYOR FOR PALLETS		
			Edition	Sheet 1 / 1



# ANNEX 2. DATASHEET OF THE COMPONENTS LOCATED ON THE LINE PROVIDED BY COMPANIES

## TABLE OF CONTENTS

1. MOTORS
  - 1.1. Flexbloc Gearmotor with NORD IEC Motor 1 SK 1SI63 - IEC80 - 80SH/4 B14 C120 TF
  - 1.2. Flexbloc Gearmotor with NORD IEC Motor 1 SK 1SI63 - IEC80 - 80LP/4 B14 C120 TF
  - 1.3. R17DRN80M4 Helical gear units R + AC motors DRN.. (IE3).
  - 1.4. R07DRN80MK4 Helical gear units R + AC motors DRN.. (IE3).
2. Calibrating – Sanding machine by Costa Levigatrizi
3. FYTJ 30 TF Oval flanged ball bearing units
4. SENSORS AND MOUNTING SYSTEMS
  - 4.1. WL12-3V2431 | W12-3 small photoelectric sensor
  - 4.2. BCG08-P1BM0336 | EcoLine wire draw encoders
  - 4.3. BEF-WG-W12 mounting system.
  - 4.4. GLL170T-B434 | GLL170 fiber-optic sensors
  - 4.5. BEF-WLL180 mounting system.
5. SCISSORS LIFT DBNA
6. IRB 760 ROBOT
7. KENOS®KVG120
8. CYLINDERS
  - 8.1. MGP-Z, Compact Guide Cylinder MGPM20TF-30Z-M9B
  - 8.2. MGP-Z, Compact Guide Cylinder MGPM40TF-30Z-M9B
  - 8.3. MGP-Z, Compact Guide Cylinder MGPM80TF-30Z-M9B
  - 8.4. MGP-Z, Compact Guide Cylinder MGPL50TF-100Z-M9B
  - 8.5. C(D)Q2, Compact Cylinder, Double Acting, Single Rod, Large Bore w/Auto Switch Mounting Groove CDQ2B125TF-30DCZ-M9B.
9. ROLLERS
  - 9.1. Heavy-duty Conveyor Roller Series 3560
  - 9.2. Heavy-duty Conveyor Roller Series 3600
10. Profiled rail guideway HGH20CA2T1400Z0H+CZS

# NORD NApEDY SP. Z O.O.

Member of the NORD DRIVESYSTEMS Group



PYNMM3 - Page 1 / 2

NORD Napedy sp. zo.o., Zakrzów 414, 32-003 Podłęże

myNORD - Guest PL

## Technical Data Sheet

Number   Date	PYNMM3.0   23/06/2021
Customer Account No.	
Created by	
Created on	23/06/2021
Field representative	Agro
Phone	+48-0122889900
Email	biuro@nord.com

Pos.	Description	Material	Quantity
1	<b>Flexbloc Gearmotor with NORD IEC Motor</b> <b>SK 1SI63 - IEC80 - 80SH/4 B14 C120 TF</b>		1
	Product Name	Worm Gears UNIVERSAL SI	
	Input Speed	1420 1/min	
	Motor Inverter Speed Range	Standard Line Powered - Inverter Capable	
	Ratio	25	
	Output Speed	57 1/min	
	Service Factor	1.9	
	Output torque	70.5 Nm	
	Overhung load	5.1 kN	
	Axial Load	7.8 kN	
	Power	0.55 kW	
	Voltage	230/400 V	
	Frequency	50 Hz	
	Efficiency Class	IE2	
	Current 1	2.44 A	
	Current 2	1.41 A	
	Cosinus	0.7	
	Motor Flange	B14 C120	
	Motor Duty	S1 - Continuous	
	Enclosure	IP55	
	Insulation	F	
	Mounting Pos	M3	
	Type of housing	Universal (Base and Face Flange)	
	IEC Motor Adapter	IEC80	
	Shaft dimension	25mm Hollow Keyed Shaft Worm Module	
	Flexbloc Shaft Design	Hollow Keyed Shaft	
	Output Shaft Dia	25H7 mm	
	Output Shaft Material	Standard	
	Gearbox Breather Options	No vent	
	Gearbox Sealing Options	Standard	
	Bearing Design	Standard Bearings	
	Motor Cooling	TEFC - Totally Enclosed Fan Cooled	
	Terminal Box Pos	1	

Konta bankowe:  
mBank S.A. - PLN  
mBank S.A. - EUR

S.W.I.F.T / BIC  
BREX PL PW KRA

NUMER  
PL61 1140 1081 0000 4726 7100 1001  
PL93 1140 1081 0000 4726 7100 1007

NORD Napedy sp. zo.o.  
Zakrzów 414  
32-003 Podłęże  
Tel.: +48 12 2889900

# NORD NAPEDY SP. Z O.O.

Member of the NORD DRIVESYSTEMS Group

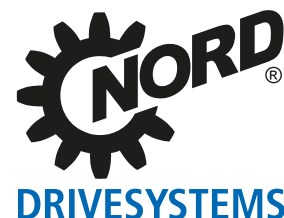

PYNMM3 - Page 2 / 2

Conduit Entry Loc	I
Cable Glands	None
Motor Option	Thermistor
Lubricant	Synthetic oil (Polyglycol) CLP PG 680
Lubricant Qty	0.18 l
Sealed Surface Conversion	No Surface Sealing Conversion
Paint Coating	not painted (F 0)
Base Weight	18.0 kg

Wymiary gabarytowe, przekroje, wykazy czesci zamiennych i inne parametry konstrukcyjne towaru jak i wymogi dotyczace obslugi i konserwacji zawarte sa w odpowiednich katalogach oraz w instrukcjach obslugi i konserwacji dostepnych na stronie internetowej producenta / producentów. Szczególna uwage nalezy zwrócic na dopuszczalne warunki obciazenia czopu wału zdawczego reduktora momentem obrotowym jak i siłami osiowymi lub/i poprzecznymi. O ile zapisy ujety powyzej nie stanowią inaczej dopuszczalna maksymalna wartosc oporowego czynnego momentu obrotowego na wale silnika wynosi  $M_n$ , gdzie  $M_n$  stanowi moment znamionowy silnika, a pozostałe dopuszczalne parametry obciazenia momentem obrotowym wynikaja z diagramu (fbmin), który ujety jest w katalogu na stronie [www.nord.com/cms/media/documents/bw/G1000\\_IE2\\_PL\\_4213.pdf](http://www.nord.com/cms/media/documents/bw/G1000_IE2_PL_4213.pdf) z tym zastrzezeniem, ze dopuszczalna maksymalna wartosc rozruchów i hamowan (Z) nie uwzglednia ograniczen wynikajacych z dopuszczalnej obciazalnosci cieplnej silnika i hamulca.

W zakresie nieokreślonym w niniejszym dokumencie zastosowanie maja przepisy określone w dokumencie oznaczonym jako Ogólne Warunki Sprzedazy (OWS), które stanowią integralną część dokumentu oznaczonego jako Potwierdzenia Zamówienia lub Oferta Sprzedazy. Sprzedawca (Nord Napedy Sp. z .o.o.) oświadcza, że treść dokumentu OWS dostępna jest na stronie [http://www2.nord.com/cms/media/documents/forms/ows\\_pl.pdf](http://www2.nord.com/cms/media/documents/forms/ows_pl.pdf) oraz może być przesłana Kupującemu w dowolny sposób, na każde zadanie Kupującego. Kupujący przyjmując Potwierdzenie Zamówienia lub Oferte Sprzedazy oświadcza, że zapoznał się z OWS. W przypadku kiedy występują różnice w zapisach ujetych w niniejszym dokumencie z zapisami ujetymi w dokumencie OWS, instrukcjach lub katalogach wiążące są zapisy ujety w niniejszym dokumencie.

**Konta bankowe:**  
mBank S.A. - PLN  
mBank S.A. - EUR

**S.W.I.F.T / BIC**  
BREX PL PW KRA

**NUMER**  
PL61 1140 1081 0000 4726 7100 1001  
PL93 1140 1081 0000 4726 7100 1007

NORD Napedy sp. zo.o.  
Zakrzów 414  
32-003 Podłęże  
Tel.: +48 12 2889900

# NORD NApEDY SP. Z O.O.

Member of the NORD DRIVESYSTEMS Group



PYNMM3 - Page 1 / 2

NORD Napędy sp. zo.o., Zakrzów 414, 32-003 Podłęże

myNORD - Guest PL

## Technical Data Sheet

Number   Date	PYNMM3.0   23/06/2021
Customer Account No.	
Created by	
Created on	23/06/2021
Field representative	Agro
Phone	+48-0122889900
Email	biuro@nord.com

Pos.	Description	Material	Quantity
1	<b>Flexbloc Gearmotor with NORD IEC Motor</b> <b>SK 1SI63 - IEC80 - 80LP/4 B14 C120 TF</b>		1
	Product Name	Worm Gears UNIVERSAL SI	
	Input Speed	1415 1/min	
	Motor Inverter Speed Range	Standard Line Powered - Inverter Capable	
	Ratio	40	
	Output Speed	35 1/min	
	Service Factor	1.1	
	Output torque	131 Nm	
	Overhung load	5.9 kN	
	Axial Load	7.8 kN	
	Power	0.75 kW	
	Voltage	230/400 V	
	Frequency	50 Hz	
	Efficiency Class	IE3	
	Current 1	3.1 A	
	Current 2	1.79 A	
	Cosinus	0.72	
	Motor Flange	B14 C120	
	Motor Duty	S1 - Continuous	
	Enclosure	IP55	
	Insulation	F	
	Mounting Pos	M3	
	Type of housing	Universal (Base and Face Flange)	
	IEC Motor Adapter	IEC80	
	Shaft dimension	25mm Hollow Keyed Shaft Worm Module	
	Flexbloc Shaft Design	Hollow Keyed Shaft	
	Output Shaft Dia	25H7 mm	
	Output Shaft Material	Standard	
	Gearbox Breather Options	No vent	
	Gearbox Sealing Options	Standard	
	Bearing Design	Standard Bearings	
	Motor Cooling	TEFC - Totally Enclosed Fan Cooled	
	Terminal Box Pos	1	

Konta bankowe:  
mBank S.A. - PLN  
mBank S.A. - EUR

S.W.I.F.T / BIC  
BREX PL PW KRA

NUMER  
PL61 1140 1081 0000 4726 7100 1001  
PL93 1140 1081 0000 4726 7100 1007

NORD Napędy sp. zo.o.  
Zakrzów 414  
32-003 Podłęże  
Tel.: +48 12 2889900

# NORD NAPEDY SP. Z O.O.

Member of the NORD DRIVESYSTEMS Group

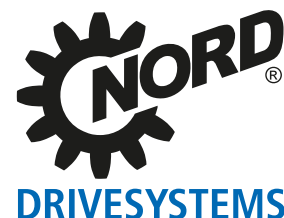

PYNMM3 - Page 2 / 2

Conduit Entry Loc	I
Cable Glands	None
Motor Option	Thermistor
Lubricant	Synthetic oil (Polyglycol) CLP PG 680
Lubricant Qty	0.18 l
Sealed Surface Conversion	No Surface Sealing Conversion
Paint Coating	not painted (F 0)
Base Weight	18.0 kg

Wymiary gabarytowe, przekroje, wykazy czesci zamiennych i inne parametry konstrukcyjne towaru jak i wymogi dotyczace obslugi i konserwacji zawarte sa w odpowiednich katalogach oraz w instrukcjach obslugi i konserwacji dostepnych na stronie internetowej producenta / producentów. Szczególna uwage nalezy zwrócic na dopuszczalne warunki obciazenia czopu wału zdawczego reduktora momentem obrotowym jak i siłami osiowymi lub/i poprzecznymi. O ile zapisy ujety powyzej nie stanowią inaczej dopuszczalna maksymalna wartosc oporowego czynnego momentu obrotowego na wale silnika wynosi  $M_n$ , gdzie  $M_n$  stanowi moment znamionowy silnika, a pozostałe dopuszczalne parametry obciazenia momentem obrotowym wynikaja z diagramu (fbmin), który ujety jest w katalogu na stronie [www.nord.com/cms/media/documents/bw/G1000\\_IE2\\_PL\\_4213.pdf](http://www.nord.com/cms/media/documents/bw/G1000_IE2_PL_4213.pdf) z tym zastrzezeniem, ze dopuszczalna maksymalna wartosc rozruchów i hamowan (Z) nie uwzglednia ograniczen wynikajacych z dopuszczalnej obciazalnosci cieplnej silnika i hamulca.

W zakresie nieokreślonym w niniejszym dokumencie zastosowanie maja przepisy określone w dokumencie oznaczonym jako Ogólne Warunki Sprzedazy (OWS), które stanowią integralną część dokumentu oznaczonego jako Potwierdzenia Zamówienia lub Oferta Sprzedazy. Sprzedawca (Nord Napedy Sp. z .o.o.) oświadcza, że treść dokumentu OWS dostępna jest na stronie [http://www2.nord.com/cms/media/documents/forms/ows\\_pl.pdf](http://www2.nord.com/cms/media/documents/forms/ows_pl.pdf) oraz może być przesłana Kupującemu w dowolny sposób, na każde zadanie Kupującego. Kupujący przyjmując Potwierdzenie Zamówienia lub Oferte Sprzedazy oświadcza, że zapoznał się z OWS. W przypadku kiedy występują różnice w zapisach ujetych w niniejszym dokumencie z zapisami ujetymi w dokumencie OWS, instrukcjach lub katalogach wiążące są zapisy ujety w niniejszym dokumencie.

**Konta bankowe:**  
mBank S.A. - PLN  
mBank S.A. - EUR

**S.W.I.F.T / BIC**  
BREX PL PW KRA

**NUMER**  
PL61 1140 1081 0000 4726 7100 1001  
PL93 1140 1081 0000 4726 7100 1007

NORD Napedy sp. zo.o.  
Zakrzów 414  
32-003 Podłęże  
Tel.: +48 12 2889900

## Catalog designation

R17DRN80M4

Helical gear units R + AC motors DRN.. (IE3)

## Product data

Rated motor speed	[1/min] : 1440
Output speed	[1/min] : 111
Overall gear ratio	: 12,98
Output torque	[Nm] : 65
Service factor SEW-FB	: 1,30
Mounting position	: M1
Base / top coat	: 7031 Blue gray (51370310)
Position of connector/terminal box	[°] : 0
Cable entry/connector position	: X
Output shaft	[mm] : 20x40
Permitted output overhung load with n=1400	[N] : 1360
Lubricant quantity 1st gear unit	[Liter] : 0,25
Motor power	[kW] : 0,75
Duration factor	: S1-100%
Efficiency class	: IE3
Efficiency (50/75/100% Pn)	[%] : 80,7 / 82,9 / 82,9
CE mark	: Yes
Motor voltage	[V] : 230/400
Wiring diagram	: R13
Frequency	[Hz] : 50
Rated current	[A] : 3,05 / 1,75
Cos Phi	: 0,74
Thermal class	: 130(B)
Motor protection type	: IP54
Design requirement	: Europe (CE)
Motor mass moment of inertia	[10 <sup>-4</sup> kgm <sup>2</sup> ] : 25,00
Weight	[kg] : 17,00

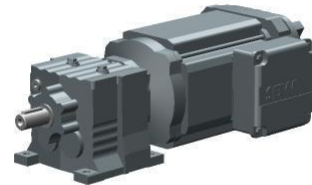

### Additional feature

Output shaft: 20x40 mm



## Catalog designation

R07DRN80MK4

Helical gear units R + AC motors DRN.. (IE3)

## Product data

Rated motor speed	[1/min] : 1435
Output speed	[1/min] : 159
Overall gear ratio	: 9,01
Output torque	[Nm] : 33
Service factor SEW-FB	: 1,50
Mounting position	: M1
Base / top coat	: 7031 Blue gray (51370310)
Position of connector/terminal box	[°] : 0
Cable entry/connector position	: X
Output shaft	[mm] : 20x40
Permitted output overhung load with n=1400	[N] : 800
Lubricant quantity 1st gear unit	[Liter] : 0,12
Motor power	[kW] : 0,55
Duration factor	: S1-100%
Efficiency class	: IE3
Efficiency (50/75/100% Pn)	[%] : 78,55 / 81 / 80,8
CE mark	: Yes
Motor voltage	[V] : 230/400
Wiring diagram	: R13
Frequency	[Hz] : 50
Rated current	[A] : 2,25 / 1,29
Cos Phi	: 0,75
Thermal class	: 130(B)
Motor protection type	: IP54
Design requirement	: Europe (CE)
Motor mass moment of inertia	[10 <sup>-4</sup> kgm <sup>2</sup> ] : 17,00
Weight	[kg] : 13,00



### Additional feature

Output shaft: 20x40 mm

# K

SERIE

# CALIBRATING - SANDING Machines

Working Widths

**650**  
**1350**  
**1650**  
**1900**  
**2200**  
**2500**  
**2800**  
**3000**

[mm]



# Calibrating - Sanding machines & "high

**SEMI-AUTOMATIC CALIBRATING LINE for CORE MATERIAL (plywood) complete with loading-stacking platforms)**

Working Width            1650 mm  
Working Speed            30 m/min  
Installed Power            270 kW



**6 units CALIBRATING MACHINE  
1<sup>st</sup> position in high-speed finishing line**

This machine is equipped with a special sound-proofed AIR-RECOVERY system to recycle the air coming from the dust filter back inside the machine,

The machine and air return are equipped with sound protections to 75 dB.





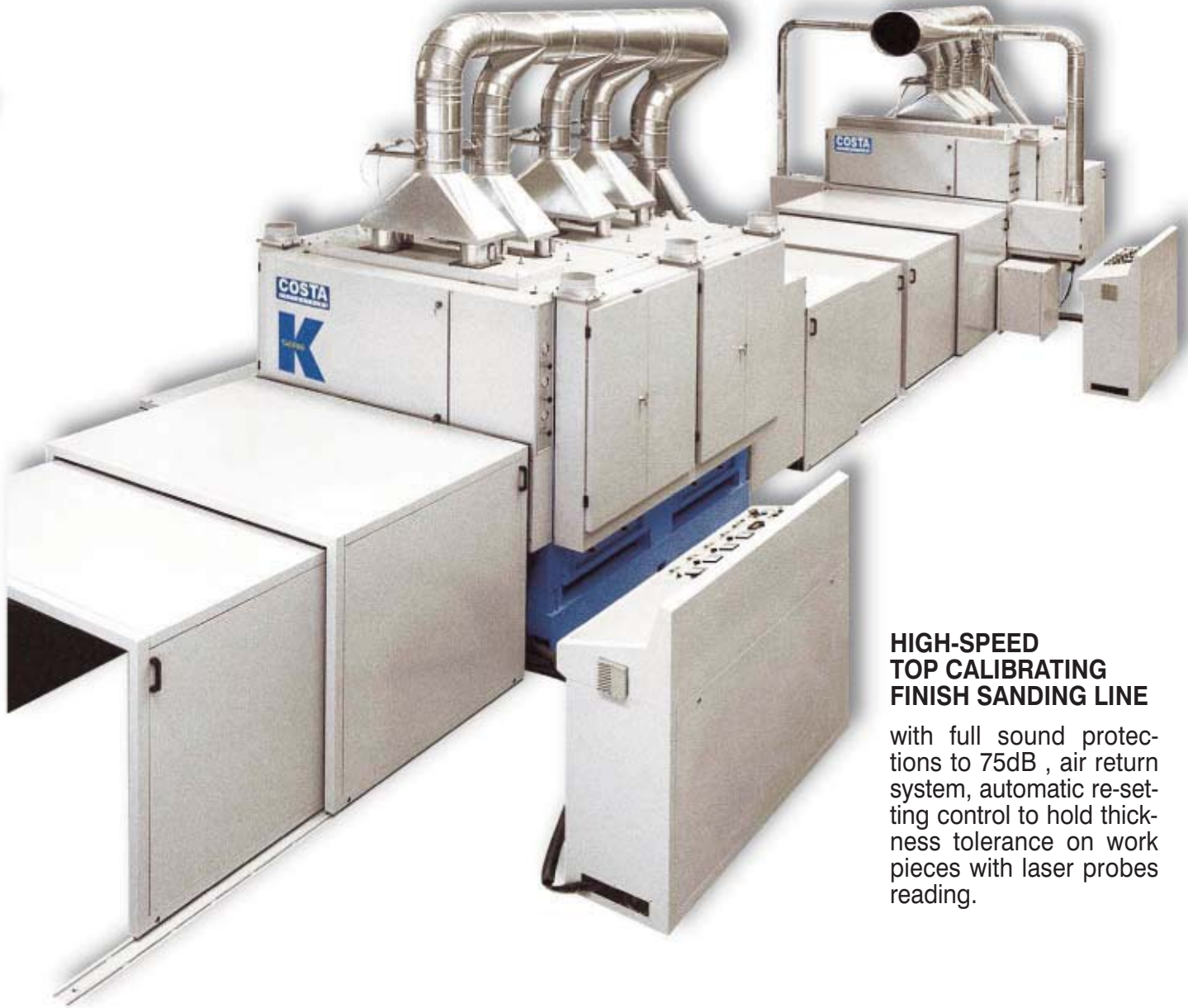

## HIGH-SPEED TOP CALIBRATING FINISH SANDING LINE

with full sound protections to 75dB , air return system, automatic re-setting control to hold thickness tolerance on work pieces with laser probes reading.



This is a line, integrated with 2 + 2 robots for feeding -stacking very special thin and flexible material, rather hard to calibrate.

Two bottom + two top heads to calibrate in the first section of the machine KK9 CC-CC , followed by another machine KK9 C-CTT with one bottom and three top units to finish.

# PARQUET FLOORING MACHINES - Example of configurations

**CALIBRATING machines** for the accurate preparation of layers (prior to pressing)

**CALIBRATING machines** utilized in the PARQUET flooring working cycle either in a stand alone or in first position of the finishing line to dimension the thickness of the planks

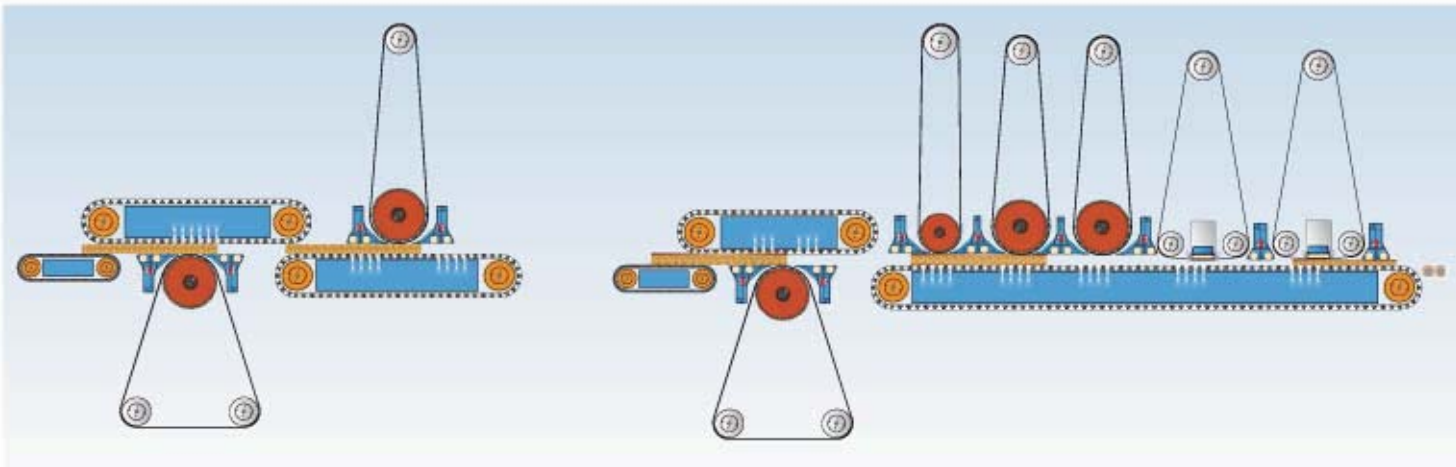

## WHY CALIBRATING THE INDIVIDUAL LAYERS ?

- to avoid taking away the exceeding thickness tolerances of the internal layers from the top layer.
- to have a more stable plank with layers with normalized thickness.
- to have a better utilization of the press, with more even pressure on the work-pieces when pressing.

After pressing, the planks must be calibrated-sanded to "perfection" prior to lacquer finishing.

This calibrating-white-wood sanding operation is normally performed in the first position of the finishing line.

A first bottom machine can be useful to level the back side of the planks, to reduce the take away from the top layer, (\*) due to tolerances adding up from other layers.

On the top side the surface finish requirement is determining the number of working units, up to 6 units on top side, depending on feed speed and take away needed.

The power of the working units is in relation to the amount of take-away, to the sanding belt grit utilized, to the feed speed of the line.

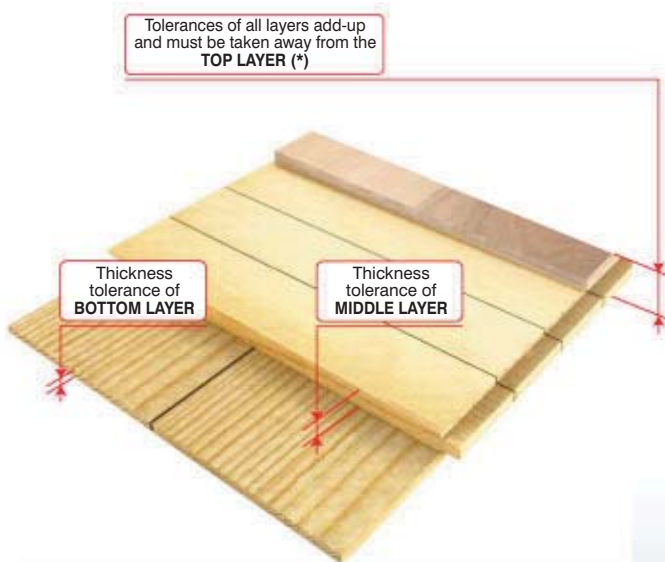



**GRAIN HIGH-LIGHTING machine**  
to brush the grain with steel-anderlon brushes

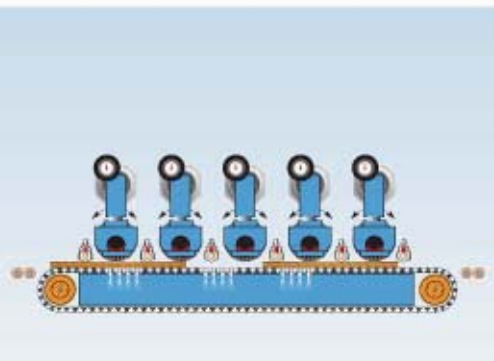

**FILLER SANDING machine**  
to level the filler applied

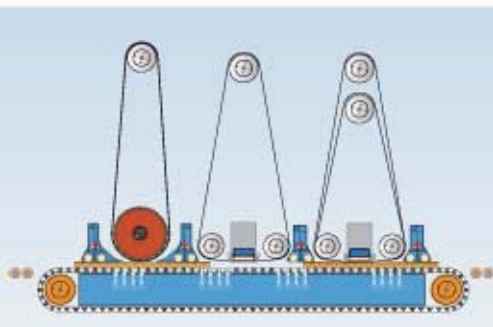

**LACQUER SANDING machine**  
utilized in the PARQUET flooring working cycle

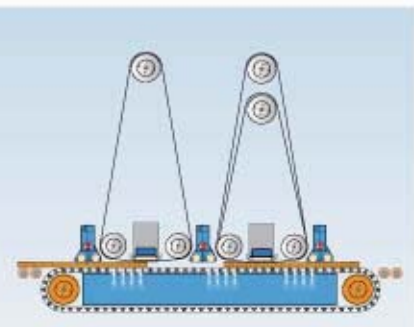

GRAIN HIGH-LIGHTING machine to brush the grain with steel-tynex/anderlon brushes.  
This machine is positioned right after the calibrating machine.  
The brushes are two for each type in use, each with the inversion of rotation to compensate the consumption of the threads, to obtain the same finish all around the knots and in the start-end of the grain (when with only 1 brush the finish is different in the grain direction and around the knots).  
We recommend 2 steel brushes, 2 tynex/anderlon and a final vegetal cleaning brush, eventually with rotary blowers in the end to clean perfectly the work-pieces .

FILLER SANDING machine is utilized in the flooring working cycle to level the filler applied to close the gaps between the top strips on the surface.  
The machine is equipped with one cylinder and one or two pad units depending on the surface finish requirement.  
The cylinder is recommended for the higher take away capacity of this unit (compare to pads) together with the easier-better cleaning possibility of the sanding belt grit to prevent clogging.

LACQUER SANDING machine utilized in the PARQUET flooring working cycle to level the lacquer applied on the surface.  
The machine is equipped with one or two pad units depending on the surface finish requirement.  
The length of the sanding belt is very important for the longer lasting time and therefore for diminishing the down time needed for the change when the belts are clogged.  
The final sanding belt grit sequence utilized ranges from 280-320 to 360-400.



# CALIBRATING - SANDING Machines



## Combined Calibrating - Sanding Machines

Series KK are our calibrating-sanding combined bottom+top machines, with up-to 4 bottom and 6 top main working units + cleaning brushes and air jet blowers for panel cleaning.

We can install high power motors for large take-away and/or for high feed speed of production.

- standard centralized thickness adjustment with electronic programmer with many programmes;
- standard centralized feed speed adjustment from control panel;
- abrasive belt length either mm. 2620 or 3250 (top machines only);
- thickness adjustment from 0 to 160 mm.



## Bottom Calibrating - Sanding Machines

- available with 1 up to 4 working units;
- constant pass-line from floor mm 1000;
- abrasive belt length 2620 mm;
- thickness adjustment from 0 to 160 mm.

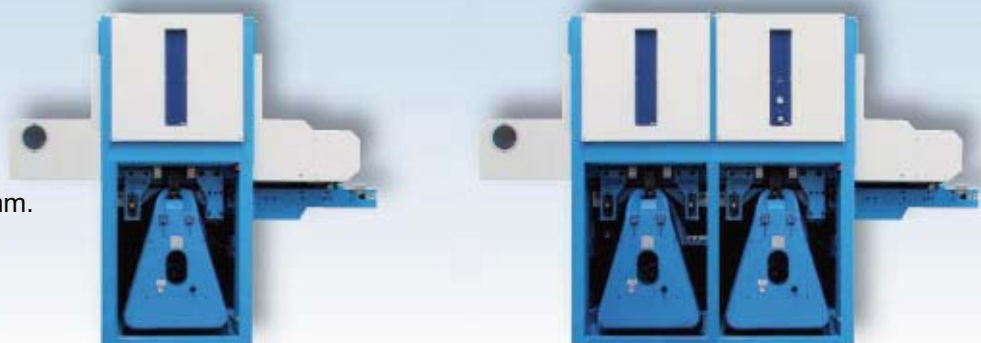



**K**  
SERIE

## Top Calibrating - Sanding Machines

- available with 1 up to 6 working units.
- constant pass-line from floor mm 1000.
- abrasive belt length 2620 / 3250 mm;
- thickness adjustment from 0 to 160 mm.

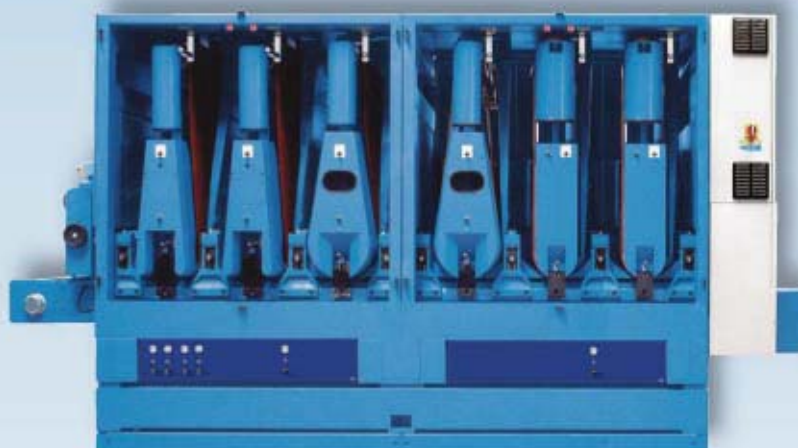

# Machines with **PLANER Head & Sanding units**

for high take-away, low power consumption, high feed speed, at lowest operating costs

Planer heads "System Costa Levigatrici" by Guillen, combined with sanding units to obtain high take away with high level of surface finish in a single pass.

Planer head equipped with carbide inserts set at an angle that is giving an "inclined" cut.

The inclined cut is smoother, less noisy and more efficient thank to the lower requirement of power.

Planer heads W250 are a formidable working unit to take away large quantities of material without problem.

Main advantages, varying from minimum 5 and up to 10 times lower costs of tips versus sanding belts, with power utilization from 50% up to 150% lower when compared with machines equipped with sanding belts, with same take-away and utilization time.

All our planer heads are equipped with standard carbide inserts dimensions mm 14 x 14 x 2 of thickness



**W250/8**

W250/8 is the unit in diameter 250 mm,

with 8 sequences of inserts



**W250/16**

W250/16 is the unit in diameter 250 mm,

with 16 sequences of inserts





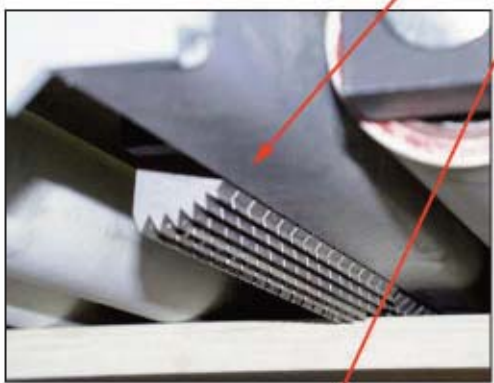
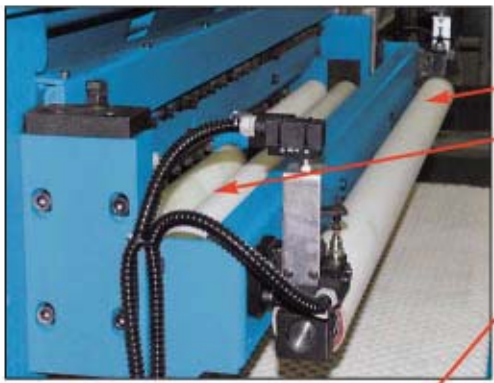
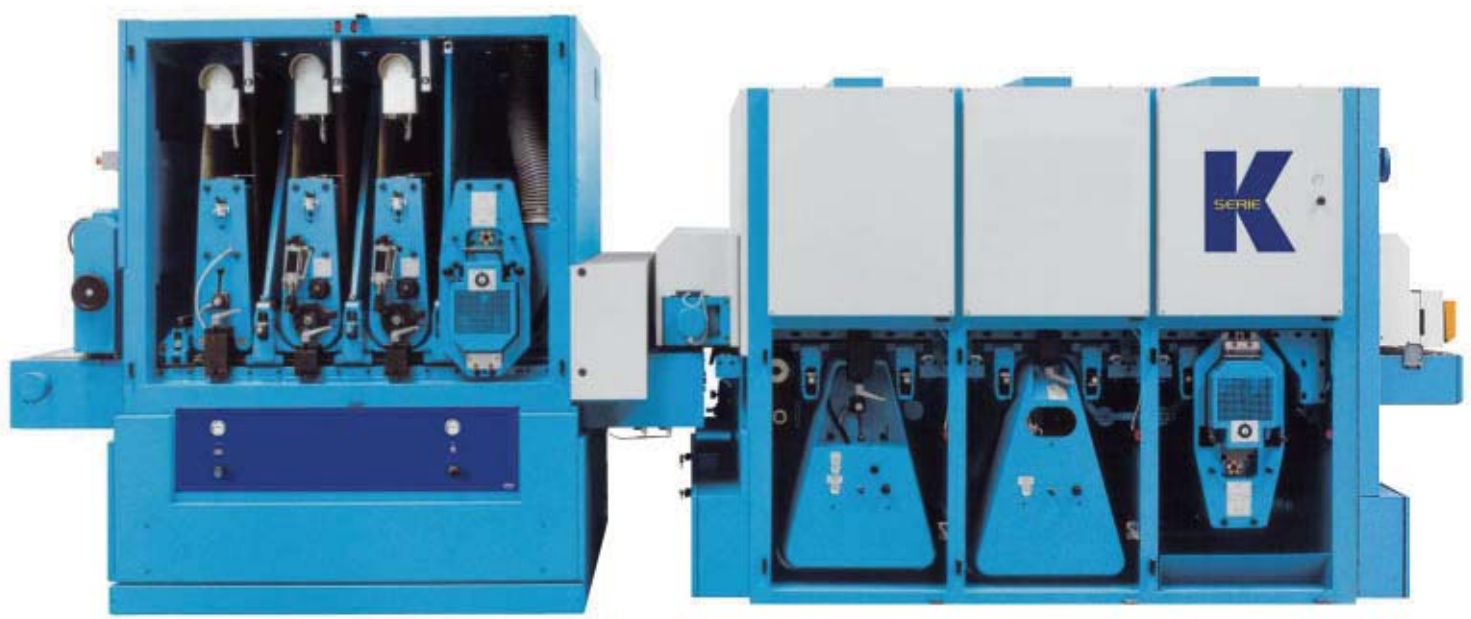

We have set 4 levels of safety for the planer head W250

- 1- Infeed roller for over-thickness at + 4 mm
- 2- Double pressure rollers rubber covered
- 3- Anti kick-back barrier
- 4- Sectioned pressure shoes with lips with pneumatic control



Each unit W250 either top or bottom as well as each spare head unit are standard equipped with trolley for carrying and positioning the heads.

# NARROW Calibrating-Sanding Machines



When sanding in line with moulders or with other machines processing narrow workpieces we have to consider the wearing of the sanding belt and also that of the feed belt of the rubber cylinders and of the pads, since they are always working in the same position.

We can overcome this problem by applying a "wide oscillation" to the sanding belts (but this only take care of the sanding belt consumption,

or we can oscillate the complete machine, and in this second case we take care of all wears (rubber belts, cylinder, sanding belts)

## (SLOW) LATERAL MACHINE OSCILLATION

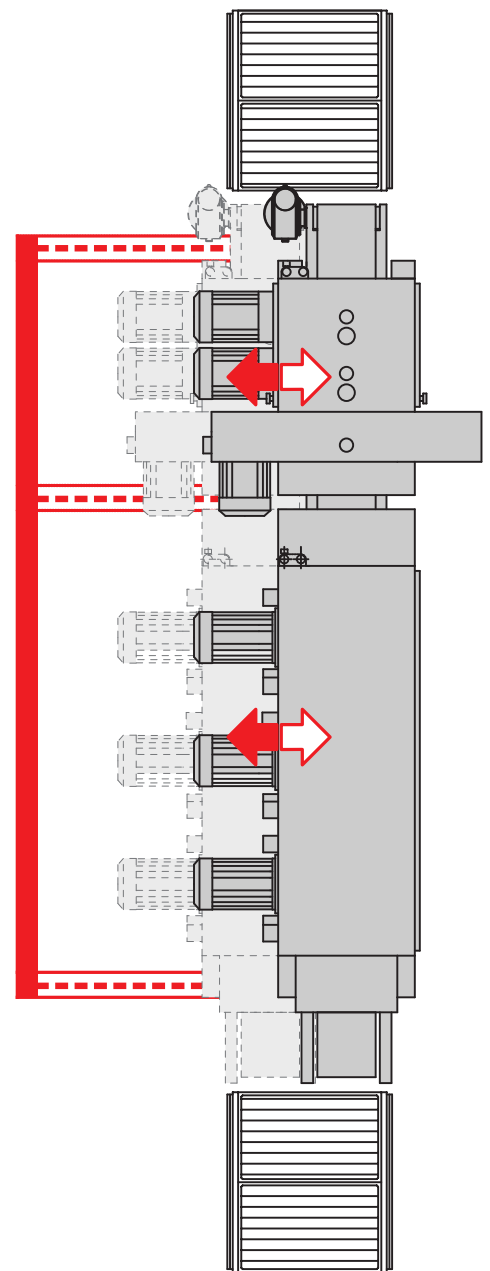

**MOULDER**

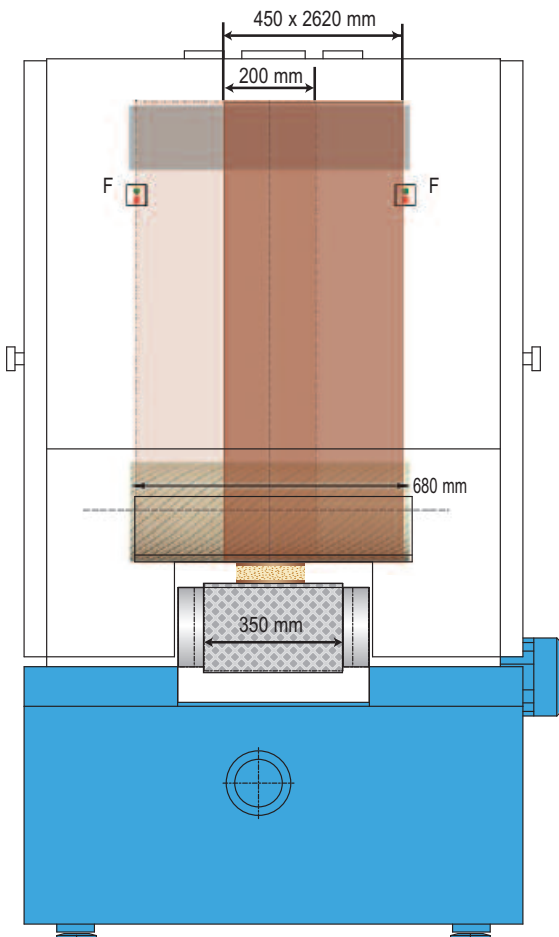

## WIDE SANDING BELTS OSCILLATION

The WIDE oscillation of the sanding belts is quite simple, we only need photocells positioned on both sides of the sanding belts.



working width 350 - 650 mm , with lateral oscillation

**COSTA**  
LEVIGATRICI

The **OSCILLATION OF THE COMPLETE MACHINE** is the most effective of the two systems of oscillation when in line with moulders (or similar operations).

We are compensating not only the wear of sanding belts but also that of the rubber elements (rubber cylinders, rubber feed belts, pad inserts), maintaining for a very long time the accuracy of calibrating-sanding operations of our machines.

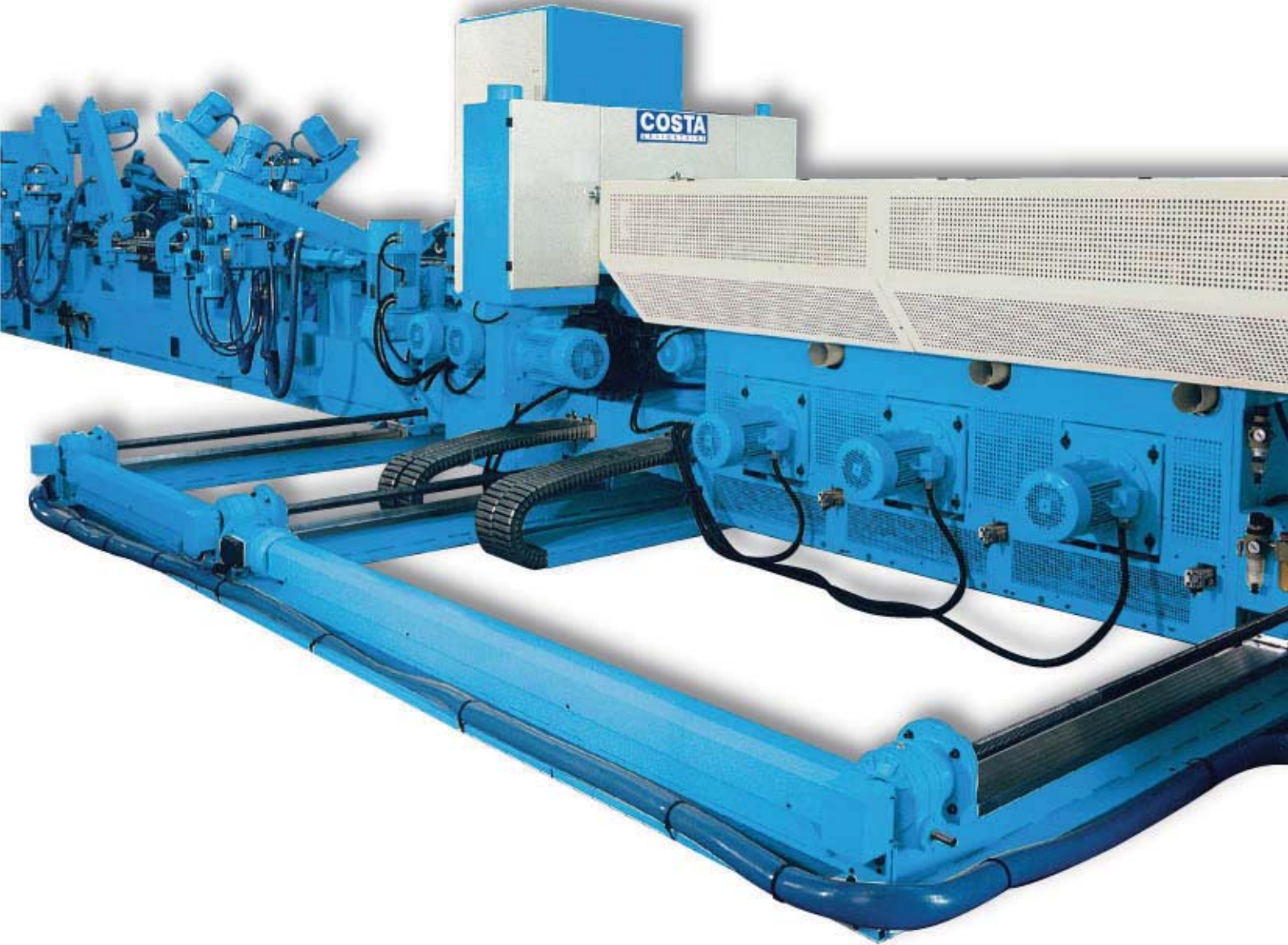

The **OSCILLATION OF THE COMPLETE MACHINE** is obtained in different ways, depending on the rate of oscillation required. needed as the translation speed is very slow.

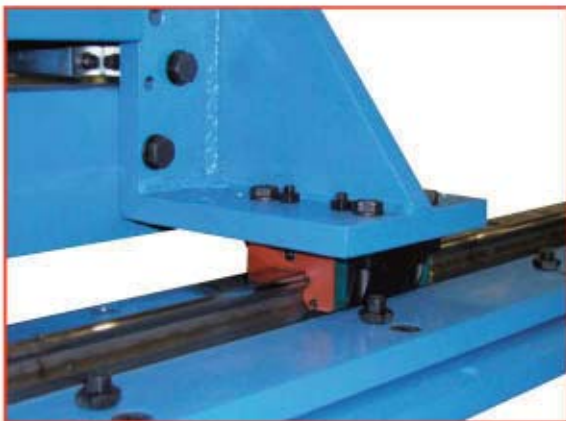



# Serie K , special features : **FEED & DRIVE SYSTEM**

A uniform feed speed is essential to obtain a constant take-away and a fine surface finish (without thickness variations or chatter-marks).

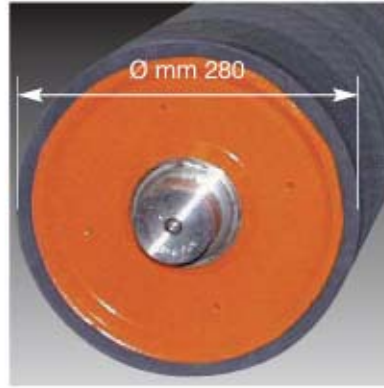

The drive system of Costa Levigatrici machines is constituted by :

- **The feed table**
- **Traction rollers rubber covered** of large diameter

- **The rubber feed belt**

We utilize first-class feed belts with close loop (no joints) with 2-3-4 layers in the internal structure, with a thick layer of rubber to enable several re-grinding operations.



Flat surface  
(for thin materials)



Raised lozenges pattern  
(for rough calibration)



Small diagonal embossed squares  
(needed with vacuum hold system)

- **The automatic centering system .**  
Safety with double switches.

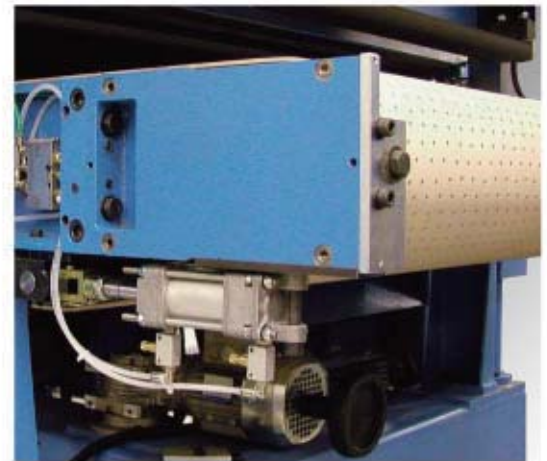
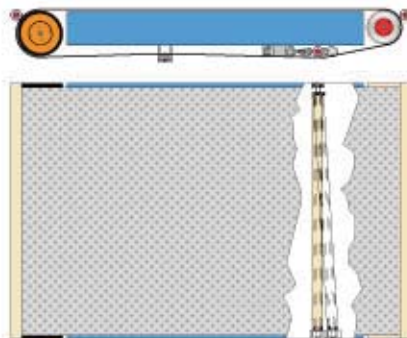
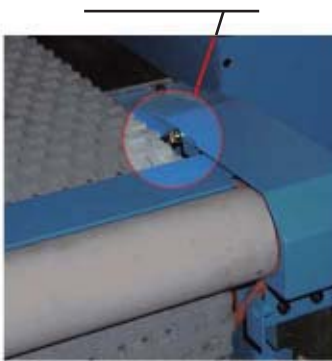

- **The feed drive unit** (see next description and pictures)

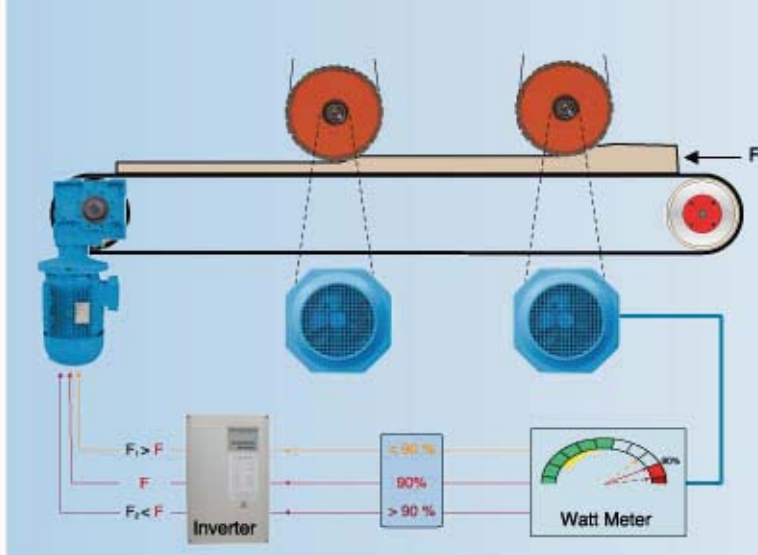

### Automatic feed speed control system - (optional)

In our calibrating machines is possible to install an automatic feed speed control " in relation to power utilization of main calibrating motors".

With such system we are certain to have the most appropriate machine utilization.

An electronic system is monitoring in real-time the power utilization of the calibrating motors.

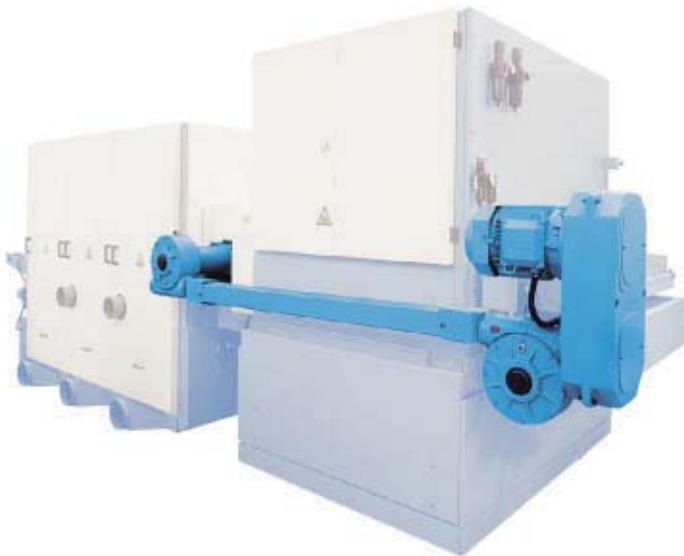

### CARDAN JOINT

The linkage with a mechanical system (with cardan joint) between the bottom and top sections of our calibrating machines is a typical Costa Levigatrici feature.

two examples of possible mechanical joint on our bottom + top machines



### ELECTRONIC JOINT

The linkage with the electronic solution is also available in our range of combined bottom + top machines.

To work properly, the system requires an immediate reaction-correction at any variation of speed of one feed belt in respect of the other belt, therefore the motors must be powerful, the electronic speed controls must be very accurate and reliable, and only in this way the system works

### CENTRALIZED THICKNESS SETTING

The thickness positioning of the bottom + top sections of Costa combined machines is made by one centralized thickness programmer (standard).

### CENTRALIZED FEED SPEED SETTING

The control of the feed speed of Costa calibrating machines is centralized in one only instrument with digital read-out of value.

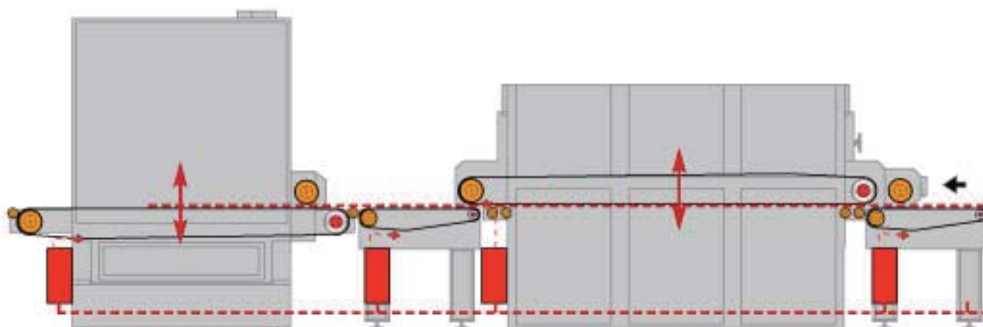

centralized thickness adjustment from 0 to 160 mm (standard)

feed speed adjustment variable from 4 - 25 m/min (standard)



# Calibrating machines control system : PLC

## PLC VISION

The PLC panel VISION enable the visualization in a touch-screen monitor of the actual setup data and operation of the machine, and to store many complete working programmes. Possibility to program only thickness and feed speed adjustment. This system is especially useful for calibrating machines, single or double (bottom + top).



In the PLC we have a number of pages available for many machine functions, each function can be stored forming complete working programmes, easy to store and recall with codes.



## PC3 (optional) - Computer control with interconnecting possibilities

Computer controlled machine

This is a PC working position that can be fully integrated in the company network. The PC control system allows to pre-set all the working programs; in addition to the total control of the machine, can also give complete production data (\*) such: number of pieces processed, working time per each code, square meter produced, compressed air, volume of dust extraction, electric power consumption, etc..

Through a modem we have the possibility to connect directly Costa Service for help and service.

(\*) note: - this connectivity to company networks usually require a specific program of communication.

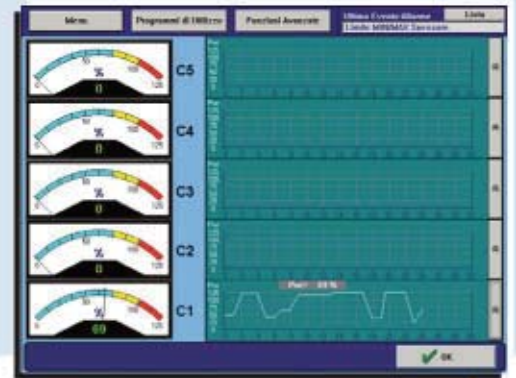

COSTA LINE MANAGER is the programme that is overlooking the passage of data between the different machines in a working line, to allow the control and the change to new working data, by recalling the code number of the work-pieces.

One PC "Line Master" is controlling all machines (or sections of line) with specific programmes and instructions for the sanding machines.

"Service Manager" is operated directly by Costa Levigatrici Service connected via modem with the PCs of the machines installed.

SUB-MASTER LINE CONTROL

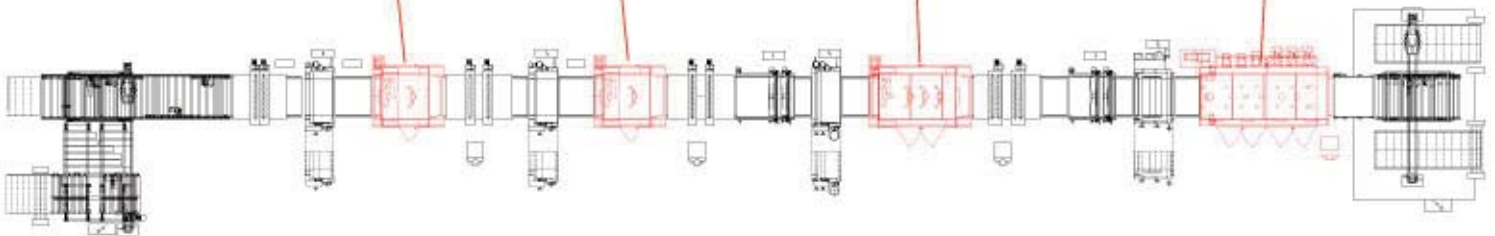



# Selective Air Jet Blowers (for saving energy - lowering air consumption)

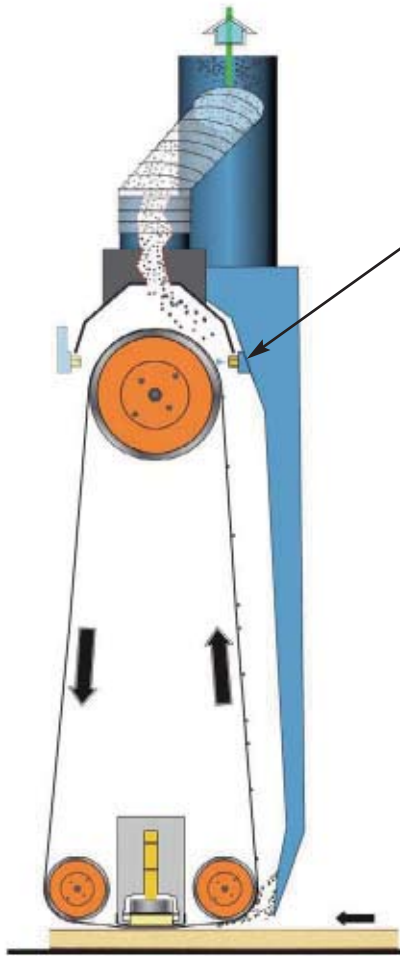

## SSE - Selective air jet blowers

With electronic control of the position, of the dimension and of the timing of activation of the single nozzles in the areas of utilization of the sanding belts.

### Optimization & efficiency of Air Jet Blowers

The position of the air jet blowers in the Costa machines is by the tension roller because it is far more efficient to clean the dust clogged in the sanding belts when the belt-grit is open.

The dust is blown-away from the belts and is directed toward the top dust-hood, that is connected with the main dust hood of the working unit.

The position by the tension roller is making possible the eventual (optional) addition of an extra jet blower bar, recommended when we need to clean fine-grit sanding belts operating on lacquer sanding.

An efficient cleaning is assuring a much longer life time to the sanding belts and is giving a better finish sanded surfaces.

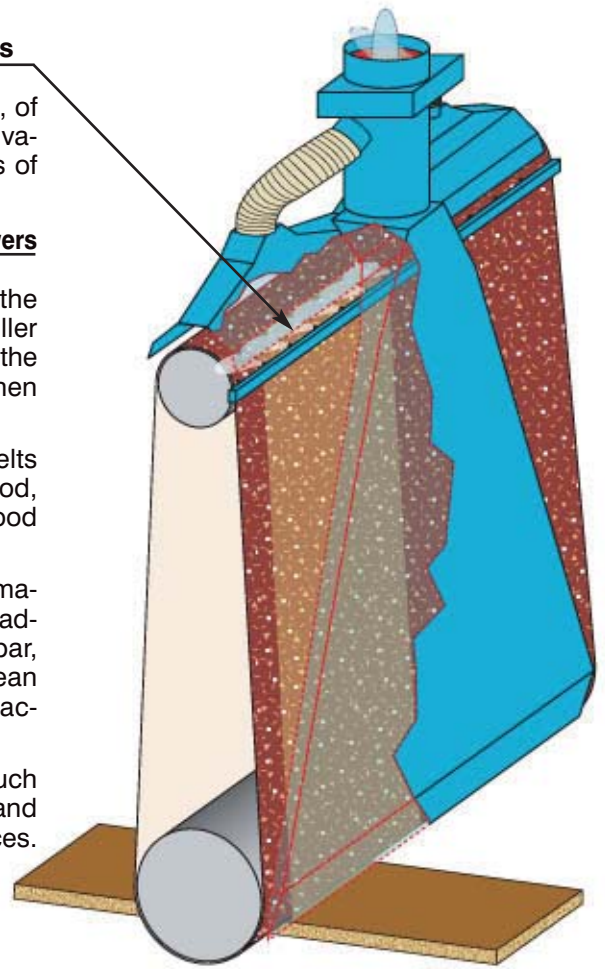

# Dust hood valves with electronic control (for saving air requirement)

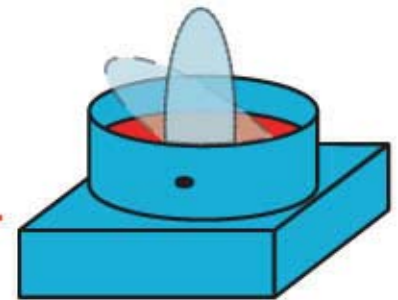
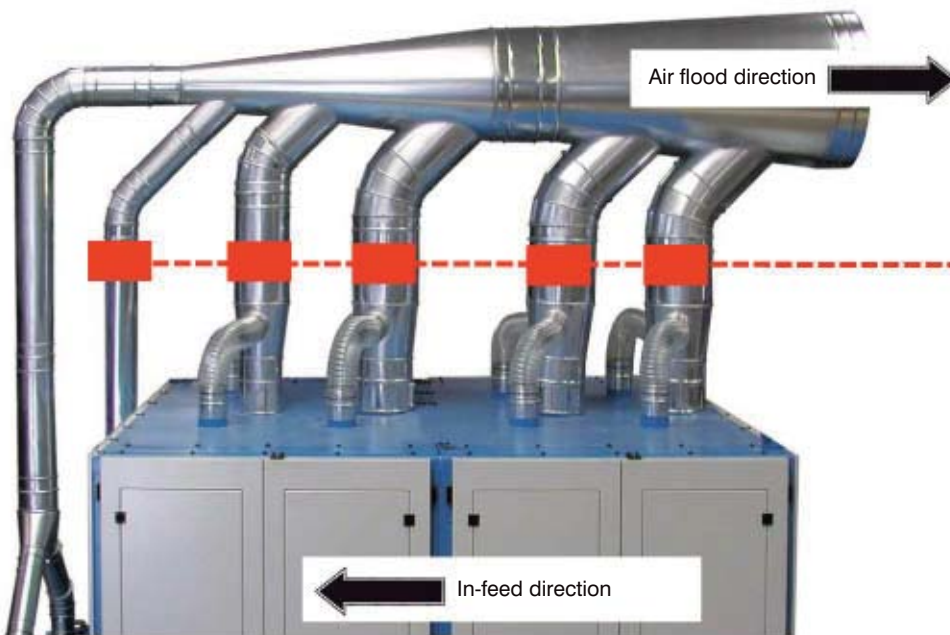

## SCA

Automatic valve for dust extraction control (optional)

A set of pneumatically operated gates are positioned in the top part of each manifold in the area of the connection to the main dust system.

The electronic control of the In-feed Sensing Bar determines the progressive opening/closing of the valves in relation to the presence of work-pieces in the machine.

**Centralized dust connectors** - this picture is a good example of an efficient dust connector:

- the entrance of the central dust system should be from the front side (since the largest amount of dust is taken away by the front working units);
- wide radius curves should be connecting the machine to the central pipe to keep the air speed high;
- an air speed of 3 ÷ 4 m/s higher than the cutting speed of the sanding belts is recommended, to make sure to easy the flood of the dust particles into the dust hoods.

An important “retro-action” control where a set of laser probes keep reading the processed panel thickness, and (eventually) is automatically resetting the machine height to the required thickness.

**TRL-3** is our LASER THICKNESS CONTROL UNIT, available on request with our calibrating machines, a measuring machine that assures an accurate reading system via a serie of opposed laser probes.



## THICKNESS READ-OUT

The TRM reading system is equipped with a monitor for the digital read-out of the values coming from the laser probes.

## PLC for the automatic cycle of resetting

The TRM reading system can be equipped with an (optional) PLC to coordinate the cycle of the re-setting process, that is:

- Read the panel thickness for a pre-determined length of space or of time;
  - Confront the thickness of the panel with the value set in the calibrating-sanding machine;
  - Determine to leave the thickness in the machine as is ....
- OR change the machine thickness to a new value, and therefore start the safety cycle for the change of thickness,

- ① Thickness SET in the machine **22.0 mm** (for example)
- ② Thickness MEASURED in the TRL **22.1 mm** (for example)
- ③ The PLC will re-set the machine thickness by **closing 0.1 mm** (to bring the panel thickness back to **22.0 mm**)

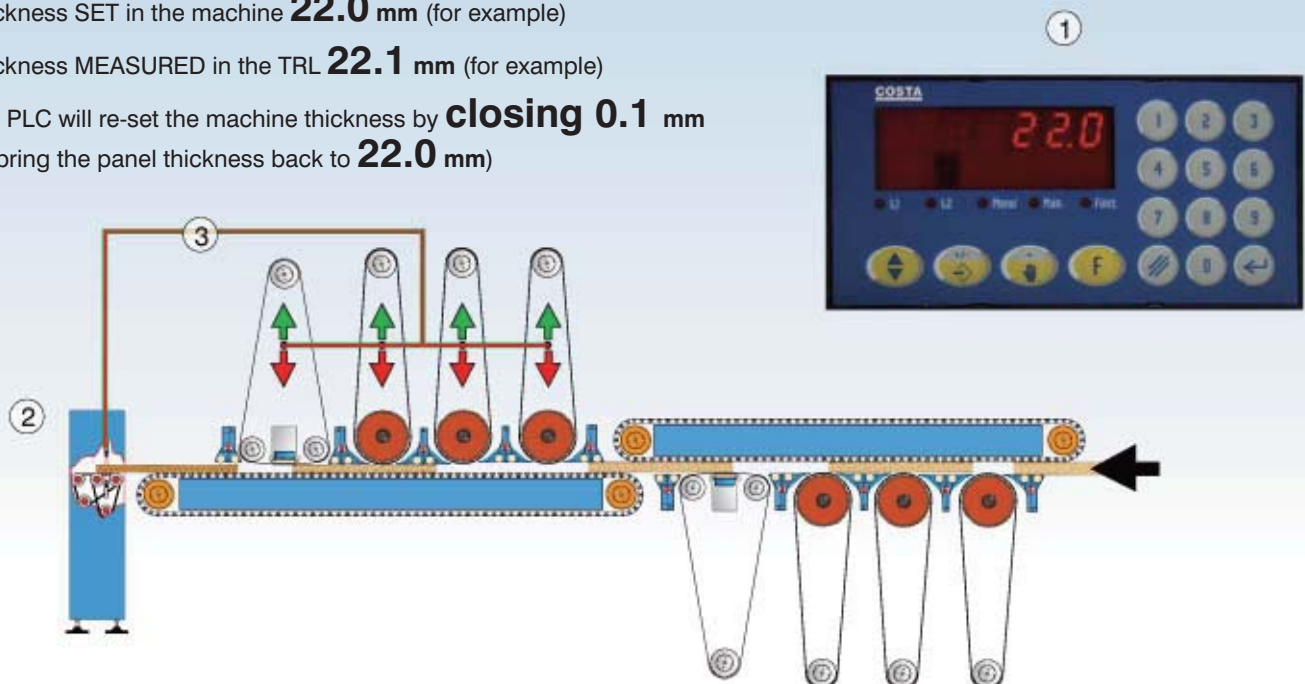



# The other lines in our range of products:

**A**  
SERIE

Universal  
Calibrating-Sanding Machines



**S**  
SERIE

Sanding Machines



**B**  
SERIE

Finishing brushing machines  
Structuring machines



We reserve the right to change features without any notice



COSTA LEVIGATRICI S.p.A.  
Via Venezia, 144 - 36015 Schio (VI) Italy  
Tel. (+39)0445-675000 – Fax (+39)0445-675110  
[www.costalev.com](http://www.costalev.com) - [info@costalev.com](mailto:info@costalev.com)

# FYTJ 30 TF Oval flanged ball bearing units

Oval flanged ball bearing units

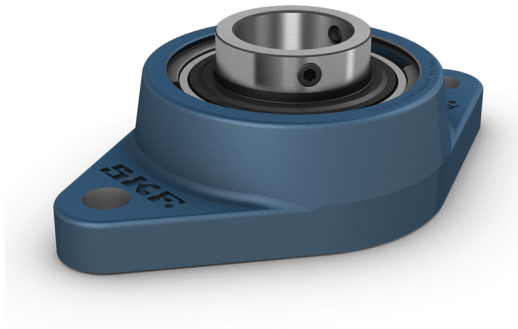

## Technical specification

Compliance with standard	JIS
Purpose specific	For material handling applications
Housing material	Cast iron
Sealing solution	Standard seals with additional flingers

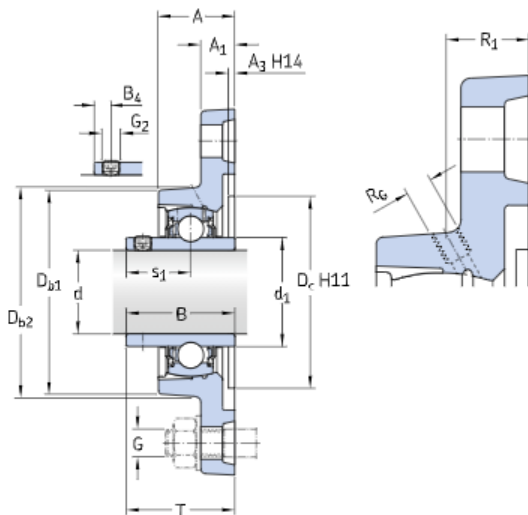

## DIMENSIONS

d	30 mm
d <sub>1</sub>	≈ 39.7 mm
A	30.5 mm
A <sub>1</sub>	13.5 mm
A <sub>3</sub>	3.2 mm
B	38.1 mm
B <sub>4</sub>	5 mm
D <sub>b1</sub>	77 mm
D <sub>b2</sub>	80 mm
D <sub>c</sub>	76.2 mm
H	148 mm
J	117 mm
L	80 mm



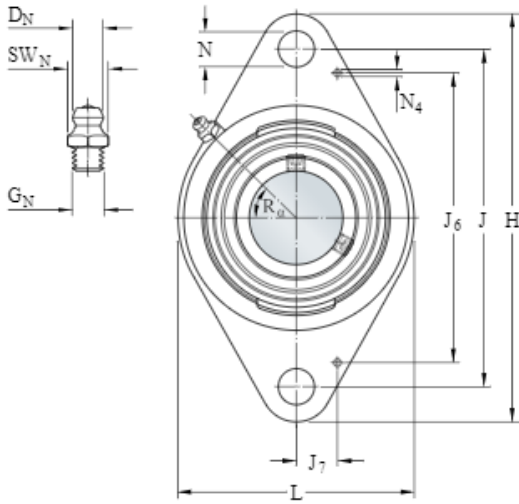

N	16 mm
s <sub>1</sub>	22.2 mm
T	40.2 mm

THREADED HOLE

R <sub>G</sub>	1/4-28 UNF
R <sub>1</sub>	19 mm
R <sub>α</sub>	45 °

GREASE FITTING

D <sub>N</sub>	6.5 mm
SW <sub>N</sub>	7 mm
G <sub>N</sub>	1/4-28 SAE-LT

DOWEL PINS

J <sub>6</sub>	99 mm
J <sub>7</sub>	12.5 mm
N <sub>4</sub>	2 mm

CALCULATION DATA

Basic dynamic load rating	C	19.5 kN
Basic static load rating	C <sub>0</sub>	11.2 kN
Fatigue load limit	P <sub>u</sub>	0.475 kN
Limiting speed		6 300 r/min
with shaft tolerance h6		

MASS

Mass bearing unit	0.87 kg
-------------------	---------

## MOUNTING INFORMATION

Set screw	G <sub>2</sub>	M6x0.75
Hexagonal key size for set screw		3 mm
Recommended tightening torque for set screw		4 N·m
Recommended diameter for attachment bolts, mm	G	14 mm
Recommended diameter for attachment bolts, inch	G	0.563 in

## INCLUDED PRODUCTS

Housing		FYTJ 506
Bearing		YAR 206-2F

## More information

Product details	Engineering information	Tools
<a href="#">Flanged units to ISO standards</a>	<a href="#">Principles of ball bearing units selection and application - Download catalogue (4.9 MB)</a>	<a href="#">Bearing Select</a>
<a href="#">Flanged units to North American standards</a>	<a href="#">Principles of selecting mounted bearing solutions</a>	<a href="#">Engineering Calculator</a>
<a href="#">Flanged units to Japanese Industrial Standards (JIS)</a>	<a href="#">Bearing failure and how to prevent it</a>	<a href="#">Rolling bearings mounting and dismounting instructions</a>
<a href="#">Flanged units, not standardized (SKF Food Line)</a>		
<a href="#">Permissible misalignment</a>		
<a href="#">Locating/non-locating support flanged</a>		
<a href="#">Loads</a>		
<a href="#">Temperature limits</a>		
<a href="#">Permissible speed</a>		
<a href="#">Lubrication</a>		
<a href="#">Mounting and dismounting</a>		
<a href="#">Ordering information</a>		
<a href="#">Designation system</a>		

# Terms and conditions

By accessing and using this website / app owned and published by AB SKF (publ.) (556007-3495 · Gothenburg) ("SKF"), you agree to the following terms and conditions:

## Warranty Disclaimer and Limitation of Liability

Although every care has been taken to assure the accuracy of the information on this website / app, SKF provides this information "AS IS" and DISCLAIMS ALL WARRANTIES, EXPRESS OR IMPLIED, INCLUDING, BUT NOT LIMITED TO, IMPLIED WARRANTIES OF MERCHANTABILITY AND FITNESS FOR A PARTICULAR PURPOSE. You acknowledge that your use of this website / app is at your sole risk, that you assume full responsibility for all costs associated with use of this website / app, and that SKF shall not be liable for any direct, incidental, consequential, or indirect damages of any kind arising out of your access to, or use of the information or software made available on this website / app. Any warranties and representations in this website / app for SKF products or services that you purchase or use will be subject to the agreed upon terms and conditions in the contract for such product or service. Further, for non-SKF websites / apps that are referenced in our website / app or where a hyperlink appears, SKF makes no warranties concerning the accuracy or reliability of the information in these websites / apps and assumes no responsibility for material created or published by third parties contained therein. In addition, SKF does not warrant that this website / app or these other linked websites / apps are free from viruses or other harmful elements.

## Copyright

Copyright in this website / app copyright of the information and software made available on this website / app rest with SKF or its licensors. All rights are reserved. All licensed material will reference the licensor that has granted SKF the right to use the material. The information and software made available on this website / app may not be reproduced, duplicated, copied, transferred, distributed, stored, modified, downloaded or otherwise exploited for any commercial use without the prior written approval of SKF. However, it may be reproduced, stored and downloaded for use by individuals without prior written approval of SKF. Under no circumstances may this information or software be supplied to third parties.

This website /app includes certain images used under license from Shutterstock, Inc.

## Trademarks and Patents

All trademarks, brand names, and corporate logos displayed on the website / app are the property of SKF or its licensors, and may not be used in any way without prior written approval by SKF. All licensed trademarks published on this website / app reference the licensor that has granted SKF the right to use the trademark. Access to this website / app does not grant to the user any license under any patents owned by or licensed to SKF.

## Changes

SKF reserves the right to make changes or additions to this website / app at any time.



# WL12-3V2431

W12-3

SMALL PHOTOELECTRIC SENSORS

**SICK**  
Sensor Intelligence.



Illustration may differ



### Ordering information

Type	Part no.
WL12-3V2431	1041537

**Included in delivery:** BEF-KH-W12 (2)

Other models and accessories → [www.sick.com/W12-3](http://www.sick.com/W12-3)

### Detailed technical data

#### Features

<b>Sensor/ detection principle</b>	Photoelectric retro-reflective sensor, autocollimation
<b>Dimensions (W x H x D)</b>	15.6 mm x 48.5 mm x 42 mm
<b>Housing design (light emission)</b>	Rectangular
<b>Sensing range max.</b>	0 m ... 7 m <sup>1)</sup>
<b>Sensing range</b>	0 m ... 5 m <sup>1)</sup>
<b>Focus</b>	Approx. 1.5°
<b>Type of light</b>	Visible red light
<b>Light source</b>	LED <sup>2)</sup>
<b>Light spot size (distance)</b>	Ø 100 mm (3 m)
<b>Angle of dispersion</b>	Approx. 1.5°
<b>Wave length</b>	640 nm
<b>Adjustment</b>	Potentiometer, 5 turns

<sup>1)</sup> Reflector PL80A.

<sup>2)</sup> Average service life: 100,000 h at T<sub>J</sub> = +25 °C.



## Mechanics/electronics

<b>Supply voltage</b>	10 V DC ... 30 V DC <sup>1)</sup>
<b>Ripple</b>	< 5 V <sub>pp</sub> <sup>2)</sup>
<b>Current consumption</b>	100 mA <sup>3)</sup>
<b>Switching output</b>	PNP
<b>Switching mode</b>	Dark switching
<b>Signal voltage PNP HIGH/LOW</b>	> U <sub>v</sub> - 2,5 V / ca. 0 V
<b>Output current I<sub>max.</sub></b>	≤ 100 mA
<b>Response time</b>	≤ 100 μs <sup>4)</sup>
<b>Switching frequency</b>	5,000 Hz <sup>5)</sup>
<b>Connection type</b>	Male connector M12, 4-pin
<b>Circuit protection</b>	A <sup>6)</sup> C <sup>7)</sup> D <sup>8)</sup>
<b>Protection class</b>	III
<b>Weight</b>	120 g
<b>Polarisation filter</b>	✓
<b>Housing material</b>	Metal
<b>Optics material</b>	Plastic, PMMA
<b>Enclosure rating</b>	IP66 IP67 IP69K
<b>Items supplied</b>	2 x clamps BEF-KH-W12, incl. screws
<b>Ambient operating temperature</b>	-40 °C ... +60 °C
<b>Ambient temperature, storage</b>	-40 °C ... +75 °C
<b>UL File No.</b>	NRKH.E181493 & NRKH7.E181493

<sup>1)</sup> Limit values when operated in short-circuit protected network: max. 8 A.

<sup>2)</sup> May not exceed or fall below U<sub>v</sub> tolerances.

<sup>3)</sup> Without load.

<sup>4)</sup> Signal transit time with resistive load.

<sup>5)</sup> With light/dark ratio 1:1.

<sup>6)</sup> A = V<sub>S</sub> connections reverse-polarity protected.

<sup>7)</sup> C = interference suppression.

<sup>8)</sup> D = outputs overcurrent and short-circuit protected.

## Safety-related parameters

<b>MTTF<sub>D</sub></b>	1,543 years
<b>DC<sub>avg</sub></b>	0%

## Classifications

<b>ECl@ss 5.0</b>	27270902
<b>ECl@ss 5.1.4</b>	27270902
<b>ECl@ss 6.0</b>	27270902
<b>ECl@ss 6.2</b>	27270902
<b>ECl@ss 7.0</b>	27270902

<b>ECl@ss 8.0</b>	27270902
<b>ECl@ss 8.1</b>	27270902
<b>ECl@ss 9.0</b>	27270902
<b>ECl@ss 10.0</b>	27270902
<b>ECl@ss 11.0</b>	27270902
<b>ETIM 5.0</b>	EC002717
<b>ETIM 6.0</b>	EC002717
<b>ETIM 7.0</b>	EC002717
<b>UNSPSC 16.0901</b>	39121528

### Connection diagram

Cd-110

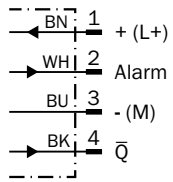

### Characteristic curve

WL12-3

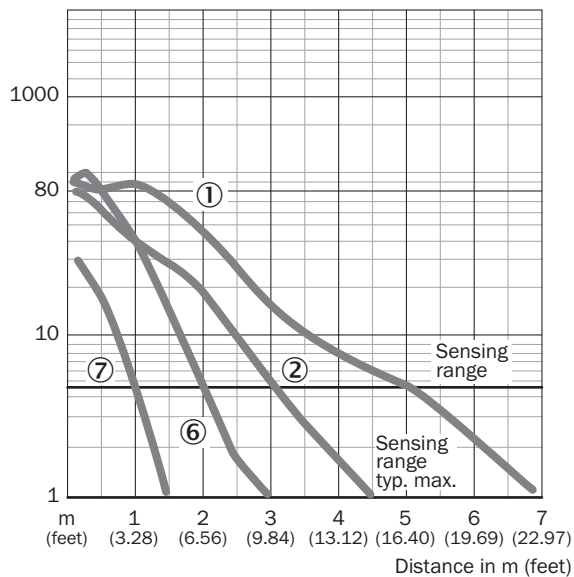

- ① Reflector PL80A
- ② Reflector C110A
- ⑥ Reflector PL20A
- ⑦ Reflective tape

## Sensing range diagram

WL12-3

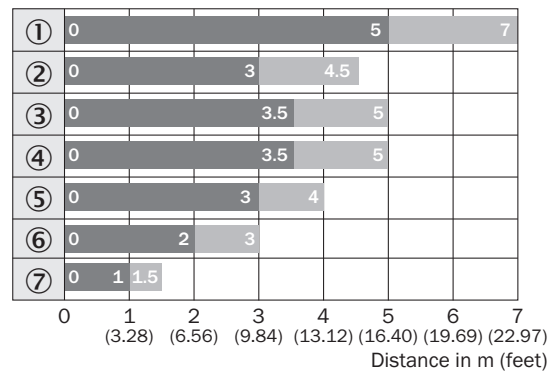

■ Sensing range      ■ Sensing range typ. max.

- ① Reflector PL80A
- ② Reflector C110A
- ③ Reflector PL50A
- ④ Reflector PL40A
- ⑤ Reflector PL30A
- ⑥ Reflector PL20A
- ⑦ Reflective tape Diamond Grade

## Adjustments

WL12-3, WSE12-3

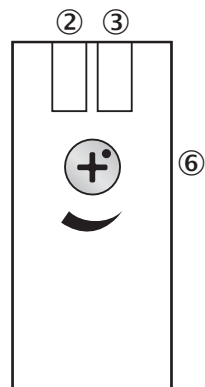

- ② LED indicator yellow: Status of received light beam
- ③ LED indicator green: Supply voltage active
- ⑥ Sensitivity control: potentiometer

### Dimensional drawing (Dimensions in mm (inch))

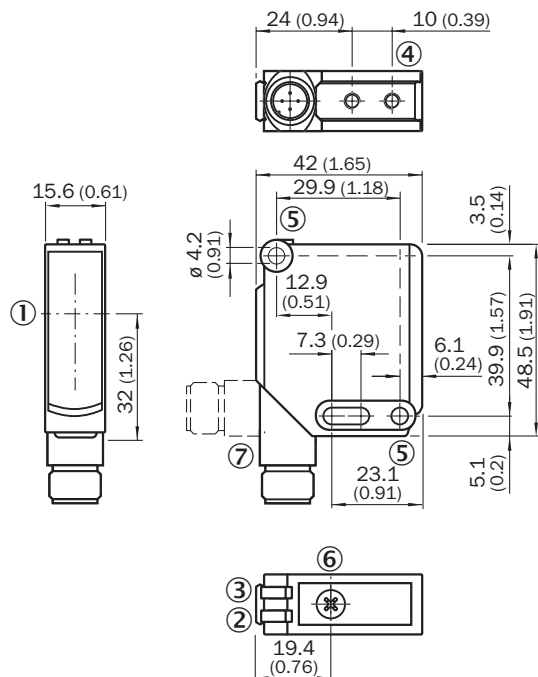

WL12-3, WSE12-3



- ① Optical axis
- ② LED indicator yellow: Status of received light beam
- ③ LED indicator green: Supply voltage active
- ④ M4 threaded mounting hole, 4 mm deep
- ⑤ Mounting hole,  $\varnothing$  4.2 mm
- ⑥ Sensitivity control: potentiometer
- ⑦ Connection

### Recommended accessories

Other models and accessories → [www.sick.com/W12-3](http://www.sick.com/W12-3)

	Brief description	Type	Part no.
<b>Mounting brackets and plates</b>			
	Universal mounting bracket for reflectors, steel, zinc coated	BEF-WN-REFX	2064574
<b>Reflectors</b>			
	Rectangular, screw connection, 18 mm x 60 mm, PMMA/ABS, Screw-on, 2 hole mounting	PL20A	1012719
<b>Plug connectors and cables</b>			
	Head A: female connector, M12, 4-pin, straight, A-coded Head B: Flying leads Cable: Sensor/actuator cable, PVC, unshielded, 5 m	YF2A14-050VB3XLEAX	2096235

	<b>Brief description</b>	<b>Type</b>	<b>Part no.</b>
	Head A: male connector, M12, 4-pin, straight Head B: - Cable: unshielded	STE-1204-G	6009932

## SICK AT A GLANCE

SICK is one of the leading manufacturers of intelligent sensors and sensor solutions for industrial applications. A unique range of products and services creates the perfect basis for controlling processes securely and efficiently, protecting individuals from accidents and preventing damage to the environment.

We have extensive experience in a wide range of industries and understand their processes and requirements. With intelligent sensors, we can deliver exactly what our customers need. In application centers in Europe, Asia and North America, system solutions are tested and optimized in accordance with customer specifications. All this makes us a reliable supplier and development partner.

Comprehensive services complete our offering: SICK LifeTime Services provide support throughout the machine life cycle and ensure safety and productivity.

For us, that is “Sensor Intelligence.”

## WORLDWIDE PRESENCE:

Contacts and other locations –[www.sick.com](http://www.sick.com)



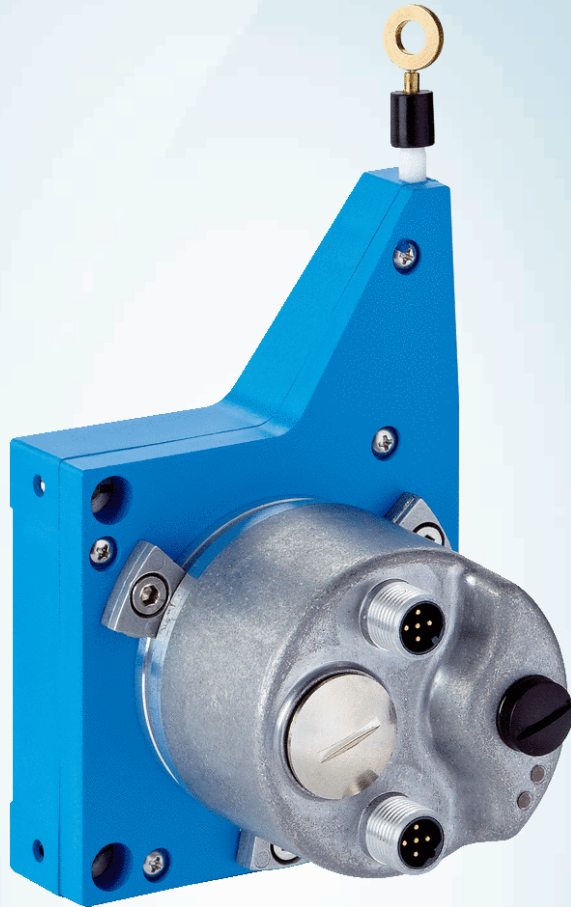

# BCG08-P1BM0336

EcoLine

WIRE DRAW ENCODERS

**SICK**  
Sensor Intelligence.

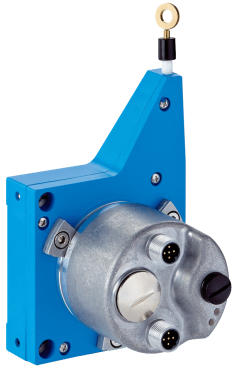

Illustration may differ



### Ordering information

Type	Part no.
BCG08-P1BM0336	1052618

**Included in delivery:** MRA-G080-103D3 (1), A3M60B-S1PB013x13 (1)

Product is supplied fully assembled. See individual components for further technical data

Other models and accessories → [www.sick.com/EcoLine](http://www.sick.com/EcoLine)

### Detailed technical data

#### Performance

BCG

<b>Measurement range</b>	0 m ... 3 m
<b>Encoder</b>	Absolute encoders
<b>Resolution (wire draw + encoder)</b>	0.03 mm <sup>1) 2)</sup>
<b>Repeatability</b>	≤ 0.2 mm <sup>3)</sup>
<b>Linearity</b>	≤ ± 2 mm <sup>3)</sup>
<b>Hysteresis</b>	≤ 0.4 mm <sup>3)</sup>

<sup>1)</sup> The values shown have been rounded.

<sup>2)</sup> Example calculation based on the BCG08 with PROFINET: 230 mm (wire draw length per revolution - see Mechanical data): 262,144 (number of steps per revolution) = 0.001 mm (resolution of wire draw + encoder combination).

<sup>3)</sup> Value applies to wire draw mechanism.

#### Interfaces

BCG

<b>Communication interface</b>	PROFIBUS DP
<b>Programmable/configurable</b>	✓

#### Electrical data

BCG

<b>Connection type</b>	Male connector, 2x, M12, 5-pin, axial Female connector, 1x, M12, 5-pin, axial
<b>Supply voltage</b>	10 V ... 32 V
<b>Power consumption</b>	≤ 1.5 W (without load)
<b>MTTF: mean time to dangerous failure</b>	60 years (EN ISO 13849-1) <sup>1)</sup>

<sup>1)</sup> This product is a standard product and does not constitute a safety component as defined in the Machinery Directive. Calculation based on nominal load of components, average ambient temperature 40 °C, frequency of use 8760 h/a. All electronic failures are considered hazardous. For more information, see document no. 8015532.

## Mechanical data

BCG

<b>Weight</b>	0.53 kg
<b>Measuring wire material</b>	Highly flexible stranded steel 1,4401 stainless steel V4A
<b>Weight (measuring wire)</b>	1.2 g/m
<b>Housing material, wire draw mechanism</b>	Plastic, Noryl
<b>Spring return force</b>	3.3 N ... 4.4 N <sup>1)</sup>
<b>Length of wire pulled out per revolution</b>	230 mm
<b>Life of wire draw mechanism</b>	Typ. 1,000,000 cycles <sup>2) 3)</sup>
<b>Actual wire draw length</b>	3.2 m
<b>Wire acceleration</b>	10 m/s <sup>2</sup>
<b>Operating speed</b>	6 m/s
<b>Mounted encoder</b>	A3M60 PROFIBUS, A3M60B-S1PB013X13, 1051018
<b>Mounted mechanic</b>	MRA-G080-103D3, 5322778

<sup>1)</sup> These values were measured at an ambient temperature of 25 °C. There may be variations at other temperatures.

<sup>2)</sup> Average values, which depend on the application.

<sup>3)</sup> The service life depends on the type of load. This is influenced by environmental conditions, the installation location, the measuring range in use, the traversing speed, and acceleration.

## Ambient data

BCG

<b>EMC</b>	According to EN 61000-6-2 and EN 61000-6-3
<b>Enclosure rating</b>	IP50
<b>Operating temperature range</b>	-10 °C ... +70 °C

## Classifications



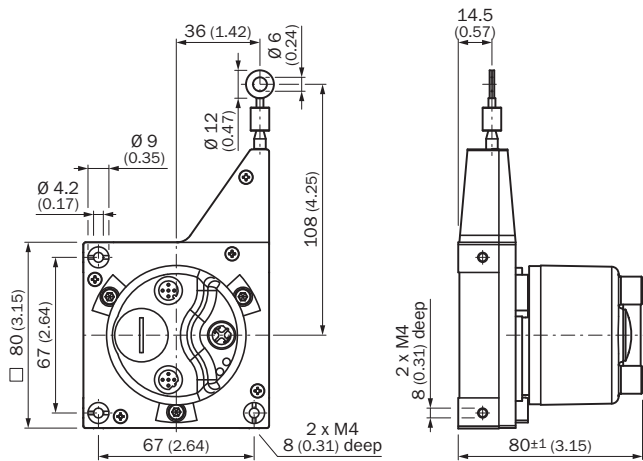

<b>ECl@ss 5.0</b>	27270590
<b>ECl@ss 5.1.4</b>	27270590
<b>ECl@ss 6.0</b>	27270590
<b>ECl@ss 6.2</b>	27270590
<b>ECl@ss 7.0</b>	27270590
<b>ECl@ss 8.0</b>	27270590
<b>ECl@ss 8.1</b>	27270590
<b>ECl@ss 9.0</b>	27270590
<b>ECl@ss 10.0</b>	27270613
<b>ECl@ss 11.0</b>	27270503
<b>ETIM 5.0</b>	EC001486
<b>ETIM 6.0</b>	EC001486
<b>ETIM 7.0</b>	EC001486
<b>UNSPSC 16.0901</b>	41112113

### Dimensional drawing (Dimensions in mm (inch))



### Recommended accessories



Other models and accessories → [www.sick.com/EcoLine](http://www.sick.com/EcoLine)

	Brief description	Type	Part no.
Wire draw mechanism			
	<ul style="list-style-type: none"> <li><b>Description:</b> EcoLine wire draw mechanism for servo flange with 6 mm shaft, measuring range 0 m ... 3 m</li> <li><b>Items supplied:</b> Without encoder</li> </ul>	MRA-G080-103D3	5322778
Flanges			
	<ul style="list-style-type: none"> <li><b>Description:</b> Flange adapter for EcoLine wire draw mechanisms, adaption of face mount flange with centering hub 20 mm to 50 mm servo flange</li> <li><b>Material:</b> Aluminum</li> <li><b>Items supplied:</b> Including 3 countersunk screws M4 x 10</li> </ul>	BEF-FA-020-050-007	2073774
Plug connectors and cables			
	<ul style="list-style-type: none"> <li><b>Connection type head A:</b> Flying leads</li> <li><b>Connection type head B:</b> Flying leads</li> <li><b>Signal type:</b> PROFIBUS DP</li> <li><b>Cable:</b> 2-wire, PUR</li> <li><b>Description:</b> PROFIBUS DP, shielded</li> </ul>	LTG-2102-MW	6021355
	<ul style="list-style-type: none"> <li><b>Connection type head A:</b> Female connector, M12, 5-pin, angled, A-coded</li> <li><b>Connection type head B:</b> Flying leads</li> <li><b>Signal type:</b> Sensor/actuator cable</li> <li><b>Cable:</b> 5 m, 3-wire, PUR, halogen-free</li> <li><b>Description:</b> Sensor/actuator cable, unshielded, Head A: female connector, M12, 5-pin, angled Head B: cable Cable: for power supply, PUR, halogen-free, shielded, 3 x 0.34 mm<sup>2</sup>, Ø 4.2 mm</li> <li><b>Note:</b> Voltage supply</li> <li><b>Application:</b> Zones with oils and lubricants</li> </ul>	D0L-1202-W05MC	6042067

	Brief description	Type	Part no.
	<ul style="list-style-type: none"> <li>• <b>Connection type head A:</b> Female connector, M12, 5-pin, angled, A-coded</li> <li>• <b>Connection type head B:</b> Flying leads</li> <li>• <b>Signal type:</b> Sensor/actuator cable</li> <li>• <b>Cable:</b> 10 m, 3-wire, PUR, halogen-free</li> <li>• <b>Description:</b> Sensor/actuator cable, unshielded, Head A: female connector, M12, 5-pin, angled Head B: cable Cable: for power supply, PUR, halogen-free, shielded, 3 x 0.34 mm<sup>2</sup>, Ø 4.2 mm</li> <li>• <b>Note:</b> Voltage supply</li> <li>• <b>Application:</b> Zones with oils and lubricants</li> </ul>	DOL-1202-W10MC	6042068
	<ul style="list-style-type: none"> <li>• <b>Connection type head A:</b> Female connector, M12, 5-pin, straight, B-coded</li> <li>• <b>Connection type head B:</b> Flying leads</li> <li>• <b>Signal type:</b> PROFIBUS DP</li> <li>• <b>Cable:</b> 5 m, 2-wire, PUR, halogen-free</li> <li>• <b>Description:</b> PROFIBUS DP, twisted pair, shielded, Head A: female connector, M12, 5-pin, straight Head B: cable Cable: suitable for drag chain, PUR, halogen-free, shielded, 2 x 0.34 mm<sup>2</sup>, Ø 8.0 mm</li> <li>• <b>Connection systems:</b> Flying leads</li> <li>• <b>Application:</b> Zones with oils and lubricants</li> </ul>	DOL-1205-G05MQ	6026006
	<ul style="list-style-type: none"> <li>• <b>Connection type head A:</b> Female connector, M12, 5-pin, straight, B-coded</li> <li>• <b>Connection type head B:</b> Flying leads</li> <li>• <b>Signal type:</b> PROFIBUS DP</li> <li>• <b>Cable:</b> 10 m, 2-wire, PUR, halogen-free</li> <li>• <b>Description:</b> PROFIBUS DP, twisted pair, shielded</li> <li>• <b>Connection systems:</b> Flying leads</li> <li>• <b>Application:</b> Zones with oils and lubricants</li> </ul>	DOL-1205-G10MQ	6026008
	<ul style="list-style-type: none"> <li>• <b>Connection type head A:</b> Female connector, M12, 5-pin, angled, B-coded</li> <li>• <b>Connection type head B:</b> Flying leads</li> <li>• <b>Signal type:</b> PROFIBUS DP</li> <li>• <b>Cable:</b> 5 m, 2-wire, PUR, halogen-free</li> <li>• <b>Description:</b> PROFIBUS DP, twisted pair, shielded</li> <li>• <b>Application:</b> Zones with oils and lubricants, Drag chain operation</li> </ul>	DOL-1205-W05MQ	6041423
	<ul style="list-style-type: none"> <li>• <b>Connection type head A:</b> Female connector, M12, 5-pin, angled, B-coded</li> <li>• <b>Connection type head B:</b> Flying leads</li> <li>• <b>Signal type:</b> PROFIBUS DP</li> <li>• <b>Cable:</b> 10 m, 2-wire, PUR, halogen-free</li> <li>• <b>Description:</b> PROFIBUS DP, twisted pair, shielded</li> <li>• <b>Application:</b> Zones with oils and lubricants</li> </ul>	DOL-1205-W10MQ	6041425
	<ul style="list-style-type: none"> <li>• <b>Connection type head A:</b> Male connector, M12, 5-pin, straight, B-coded</li> <li>• <b>Connection type head B:</b> Flying leads</li> <li>• <b>Signal type:</b> PROFIBUS DP</li> <li>• <b>Cable:</b> 5 m, 2-wire, PUR, halogen-free</li> <li>• <b>Description:</b> PROFIBUS DP, twisted pair, shielded</li> <li>• <b>Note:</b> Wire shield Al-Pt film, overall shield C-screen tin-plated</li> <li>• <b>Application:</b> Zones with oils and lubricants, Drag chain operation</li> </ul>	STL-1205-G05MQ	6026005
	<ul style="list-style-type: none"> <li>• <b>Connection type head A:</b> Male connector, M12, 5-pin, straight, B-coded</li> <li>• <b>Connection type head B:</b> Flying leads</li> <li>• <b>Signal type:</b> PROFIBUS DP</li> <li>• <b>Cable:</b> 10 m, 2-wire, PUR, halogen-free</li> <li>• <b>Description:</b> PROFIBUS DP, twisted pair, shielded</li> <li>• <b>Note:</b> Wire shield Al-Pt film, overall shield C-screen tin-plated</li> <li>• <b>Application:</b> Zones with oils and lubricants, Drag chain operation</li> </ul>	STL-1205-G10MQ	6026007
	<ul style="list-style-type: none"> <li>• <b>Connection type head A:</b> Male connector, M12, 5-pin, angled, B-coded</li> <li>• <b>Connection type head B:</b> Flying leads</li> <li>• <b>Signal type:</b> PROFIBUS DP</li> <li>• <b>Cable:</b> 5 m, 2-wire, PUR, halogen-free</li> <li>• <b>Description:</b> PROFIBUS DP, twisted pair, shielded</li> <li>• <b>Application:</b> Zones with oils and lubricants, Drag chain operation</li> </ul>	STL-1205-W05MQ	6041426

	Brief description	Type	Part no.
	<ul style="list-style-type: none"> <li>• <b>Connection type head A:</b> Male connector, M12, 5-pin, angled, B-coded</li> <li>• <b>Connection type head B:</b> Flying leads</li> <li>• <b>Signal type:</b> PROFIBUS DP</li> <li>• <b>Cable:</b> 10 m, 2-wire, PUR, halogen-free</li> <li>• <b>Description:</b> PROFIBUS DP, twisted pair, shielded</li> <li>• <b>Application:</b> Zones with oils and lubricants, Drag chain operation</li> </ul>	STL-1205-W10MQ	6041427
	<ul style="list-style-type: none"> <li>• <b>Connection type head A:</b> Female connector, M12, 5-pin, straight, A-coded</li> <li>• <b>Connection type head B:</b> Flying leads</li> <li>• <b>Authorizations:</b> CE, UL</li> <li>• <b>Signal type:</b> Sensor/actuator cable</li> <li>• <b>Cable:</b> 5 m, 5-wire, PUR, halogen-free</li> <li>• <b>Description:</b> Sensor/actuator cable, shielded</li> <li>• <b>Application:</b> Zones with oils and lubricants, Drag chain operation</li> </ul>	YF2A25-050UB6XLEAX	2095733
	<ul style="list-style-type: none"> <li>• <b>Connection type head A:</b> Female connector, M12, 5-pin, straight, A-coded</li> <li>• <b>Connection type head B:</b> Flying leads</li> <li>• <b>Authorizations:</b> CE, UL</li> <li>• <b>Signal type:</b> Sensor/actuator cable</li> <li>• <b>Cable:</b> 10 m, 5-wire, PUR, halogen-free</li> <li>• <b>Description:</b> Sensor/actuator cable, shielded</li> <li>• <b>Application:</b> Zones with oils and lubricants, Drag chain operation</li> </ul>	YF2A25-100UB6XLEAX	2095734
	<ul style="list-style-type: none"> <li>• <b>Connection type head A:</b> Female connector, M12, 5-pin, straight, A-coded</li> <li>• <b>Connection type head B:</b> Flying leads</li> <li>• <b>Authorizations:</b> CE, UL</li> <li>• <b>Signal type:</b> Sensor/actuator cable</li> <li>• <b>Cable:</b> 20 m, 5-wire, PUR, halogen-free</li> <li>• <b>Description:</b> Sensor/actuator cable, shielded</li> <li>• <b>Application:</b> Zones with oils and lubricants, Drag chain operation</li> </ul>	YF2A25-200UB6XLEAX	2095738
	<ul style="list-style-type: none"> <li>• <b>Connection type head A:</b> Female connector, M12, 5-pin, straight, B-coded</li> <li>• <b>Connection type head B:</b> Male connector, M12, 5-pin, straight, B-coded</li> <li>• <b>Signal type:</b> PROFIBUS DP</li> <li>• <b>Cable:</b> 10 m, 2-wire, PUR, halogen-free</li> <li>• <b>Description:</b> PROFIBUS DP, twisted pair, shielded</li> <li>• <b>Note:</b> Wire shield Al-Pt film, overall shield C-screen tin-plated</li> <li>• <b>Application:</b> Zones with oils and lubricants, Drag chain operation</li> </ul>	DSL-1205-G10MQ	6032640
	<ul style="list-style-type: none"> <li>• <b>Connection type head A:</b> Female connector, M12, 4-pin, straight</li> <li>• <b>Connection type head B:</b> -</li> <li>• <b>Authorizations:</b> UL</li> <li>• <b>Description:</b> Unshielded, Head A: female connector, M12, 4-pin, straight, unshielded, for power supply, for cable diameter 4 mm ... 6 mm Head B: -</li> <li>• <b>Connection systems:</b> Screw-type terminals</li> <li>• <b>Permitted cross-section:</b> ≤ 0.75 mm<sup>2</sup></li> </ul>	DOS-1204-G	6007302
	<ul style="list-style-type: none"> <li>• <b>Connection type head A:</b> Female connector, M12, 4-pin, angled</li> <li>• <b>Connection type head B:</b> -</li> <li>• <b>Authorizations:</b> UL</li> <li>• <b>Description:</b> Unshielded, Head A: female connector, M12, 4-pin, angled, unshielded, for power supply, for cable diameter 3 mm ... 6.5 mm Head B: -</li> <li>• <b>Connection systems:</b> Screw-type terminals</li> <li>• <b>Permitted cross-section:</b> ≤ 0.75 mm<sup>2</sup></li> </ul>	DOS-1204-W	6007303
	<ul style="list-style-type: none"> <li>• <b>Connection type head A:</b> Female connector, M12, 5-pin, straight, B-coded</li> <li>• <b>Connection type head B:</b> -</li> <li>• <b>Signal type:</b> PROFIBUS DP</li> <li>• <b>Description:</b> PROFIBUS DP, shielded, Head A: M12 female connector, 5-pin, straight, B-coded, PROFIBUS DP, shielded, for cable diameter 4 mm ... 9 mm Head B: -</li> <li>• <b>Connection systems:</b> Screw-type terminals</li> <li>• <b>Permitted cross-section:</b> ≤ 0.75 mm<sup>2</sup></li> </ul>	DOS-1205-GQ	6021353
	<ul style="list-style-type: none"> <li>• <b>Connection type head A:</b> Female connector, M12, 5-pin, angled, B-coded (B-reverse)</li> <li>• <b>Connection type head B:</b> -</li> <li>• <b>Signal type:</b> PROFIBUS DP, PROFIBUS DP</li> <li>• <b>Description:</b> PROFIBUS DP, shielded, Head A: female connector, M12, 5-pin, angled, B-coded, shielded, for cable diameter 4 mm ... 8 mm Head B: -, PROFIBUS DP</li> <li>• <b>Connection systems:</b> Spring-cage connection</li> <li>• <b>Permitted cross-section:</b> 0.14 mm<sup>2</sup> ... 0.5 mm<sup>2</sup></li> </ul>	DOS-1205-WQ	6041429



	Brief description	Type	Part no.
	<ul style="list-style-type: none"> <li>• <b>Connection type head A:</b> Male connector, M12, 5-pin, straight, B-coded</li> <li>• <b>Connection type head B:</b> -</li> <li>• <b>Signal type:</b> PROFIBUS DP</li> <li>• <b>Description:</b> PROFIBUS DP, shielded, Head A: male connector, M12, 5-pin, straight, B coded, shielded, for cable diameter 4 mm ... 9 mm Head B: -</li> <li>• <b>Connection systems:</b> Screw-type terminals</li> <li>• <b>Permitted cross-section:</b> <math>\leq 0.75 \text{ mm}^2</math></li> </ul>	STE-1205-GQ	6021354
	<ul style="list-style-type: none"> <li>• <b>Connection type head A:</b> Male connector, M12, 5-pin, angled, B-coded</li> <li>• <b>Connection type head B:</b> -</li> <li>• <b>Signal type:</b> PROFIBUS DP</li> <li>• <b>Description:</b> PROFIBUS DP, shielded, Head A: male connector, M12, 5-pin, angled, B coded, shielded, for cable diameter 4 mm ... 8 mm Head B: -</li> <li>• <b>Connection systems:</b> Spring-cage connection</li> <li>• <b>Permitted cross-section:</b> <math>0.14 \text{ mm}^2 \dots 0.5 \text{ mm}^2</math></li> </ul>	STE-1205-WQ	6041428
	<ul style="list-style-type: none"> <li>• <b>Description:</b> Unshielded, A3M60 accessories sales set comprising: Female cable connector, supply voltage, M12, angled (6007303) female cable connector, M12, angled (6041429), male cable connector, M12, angled (6041428)</li> <li>• <b>Note:</b> Set of connectors</li> </ul>	DOS-3XM12-W	2058177
	<ul style="list-style-type: none"> <li>• <b>Connection type head A:</b> Male connector, M12, 4-pin, straight, B-coded</li> <li>• <b>Signal type:</b> PROFIBUS DP</li> <li>• <b>Description:</b> PROFIBUS DP, terminal resistor</li> </ul>	STE-END-Q	6021156

## SICK AT A GLANCE

SICK is one of the leading manufacturers of intelligent sensors and sensor solutions for industrial applications. A unique range of products and services creates the perfect basis for controlling processes securely and efficiently, protecting individuals from accidents and preventing damage to the environment.

We have extensive experience in a wide range of industries and understand their processes and requirements. With intelligent sensors, we can deliver exactly what our customers need. In application centers in Europe, Asia and North America, system solutions are tested and optimized in accordance with customer specifications. All this makes us a reliable supplier and development partner.

Comprehensive services complete our offering: SICK LifeTime Services provide support throughout the machine life cycle and ensure safety and productivity.

For us, that is “Sensor Intelligence.”

## WORLDWIDE PRESENCE:

Contacts and other locations –[www.sick.com](http://www.sick.com)

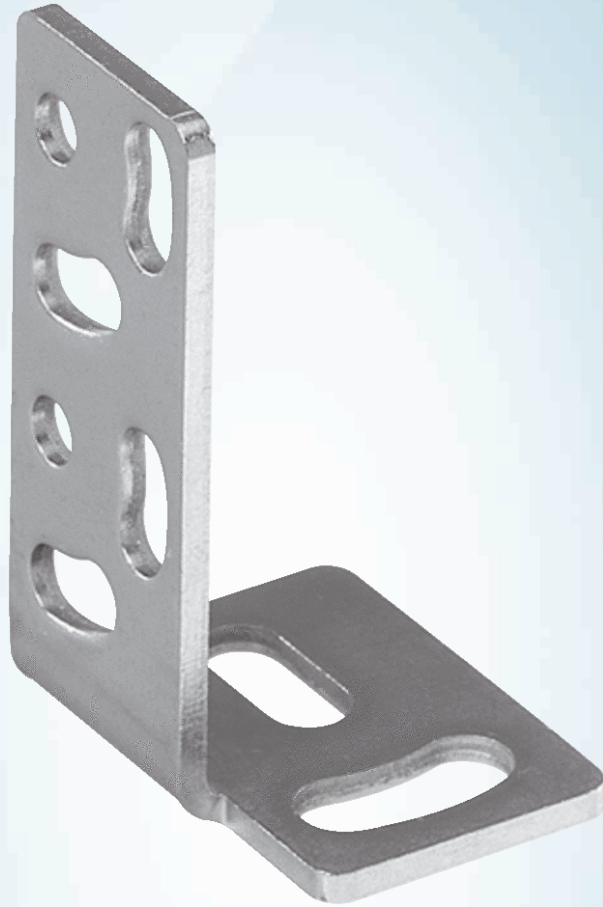

BEF-WG-W12

**SICK**  
Sensor Intelligence.

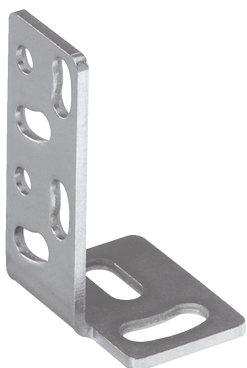

## Ordering information

Type	Part no.
BEF-WG-W12	2013942

Other models and accessories → [www.sick.com/](http://www.sick.com/)

## Detailed technical data

### Technical specifications

<b>Accessory group</b>	Mounting brackets and plates
<b>Accessory family</b>	Mounting brackets
<b>Suitable for</b>	W11-2, W12-3, W16
<b>Material</b>	Stainless steel
<b>Items supplied</b>	Mounting hardware included
<b>Description</b>	Mounting bracket, large

### Classifications

<b>ECl@ss 5.0</b>	27279202
<b>ECl@ss 5.1.4</b>	27279202
<b>ECl@ss 6.0</b>	27279202
<b>ECl@ss 6.2</b>	27279202
<b>ECl@ss 7.0</b>	27279202
<b>ECl@ss 8.0</b>	27279202
<b>ECl@ss 8.1</b>	27279202
<b>ECl@ss 9.0</b>	27273701
<b>ECl@ss 10.0</b>	27273701
<b>ECl@ss 11.0</b>	27273701
<b>ETIM 5.0</b>	EC002615
<b>ETIM 6.0</b>	EC002615
<b>ETIM 7.0</b>	EC002615
<b>UNSPSC 16.0901</b>	32131023

Dimensional drawing (Dimensions in mm (inch))

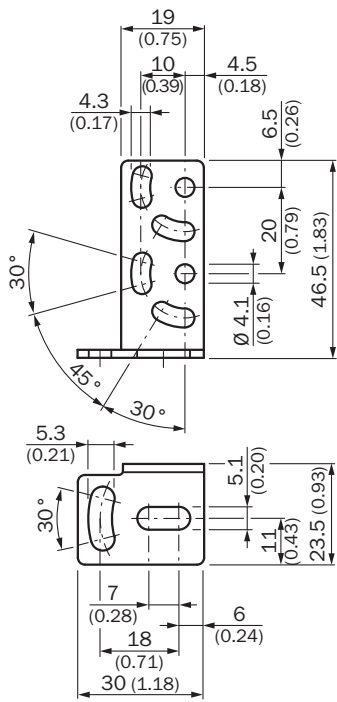

## SICK AT A GLANCE

SICK is one of the leading manufacturers of intelligent sensors and sensor solutions for industrial applications. A unique range of products and services creates the perfect basis for controlling processes securely and efficiently, protecting individuals from accidents and preventing damage to the environment.

We have extensive experience in a wide range of industries and understand their processes and requirements. With intelligent sensors, we can deliver exactly what our customers need. In application centers in Europe, Asia and North America, system solutions are tested and optimized in accordance with customer specifications. All this makes us a reliable supplier and development partner.

Comprehensive services complete our offering: SICK LifeTime Services provide support throughout the machine life cycle and ensure safety and productivity.

For us, that is “Sensor Intelligence.”

## WORLDWIDE PRESENCE:

Contacts and other locations –[www.sick.com](http://www.sick.com)





# GLL170T-B434

GLL170

FIBER-OPTIC SENSORS

**SICK**  
Sensor Intelligence.



Illustration may differ



### Ordering information

Type	Part no.
GLL170T-B434	6063341

Other models and accessories → [www.sick.com/GLL170](http://www.sick.com/GLL170)

### Detailed technical data

#### Features

<b>Type</b>	Stand-alone
<b>Dimensions (W x H x D)</b>	10 mm x 31.7 mm x 72.5 mm
<b>Housing design (light emission)</b>	Rectangular
<b>Sensing range max.</b>	0 mm ... 400 mm, Proximity system <sup>1) 2)</sup> 0 mm ... 1,320 mm, Through-beam system <sup>3)</sup>
<b>Sensing range</b>	0 mm ... 350 mm, Proximity system <sup>1) 2)</sup> 0 mm ... 1,100 mm, Through-beam system <sup>3)</sup>
<b>Type of light</b>	Visible red light
<b>Light source</b>	LED <sup>4)</sup>
<b>Wave length</b>	632 nm
<b>Adjustment</b>	Teach-in button Cable Plus/minus button
<b>Indication</b>	Display
<b>Display</b>	Status LEDs, 4-digit digital display, display selectable between percentage value, absolute digit value and bar display / display of parameters

<sup>1)</sup> Object with 90 % reflectance (referred to standard white, DIN 5033).

<sup>2)</sup> LL3-DK06.

<sup>3)</sup> LL3-TB02.

<sup>4)</sup> Average service life: 100,000 h at T<sub>J</sub> = +25 °C.

## Mechanics/electronics

<b>Supply voltage</b>	10 V DC ... 30 V DC <sup>1)</sup>
<b>Ripple</b>	≤ 10 % <sup>2)</sup>
<b>Switching output</b>	PNP NPN Selectable via menu
<b>Number of switching outputs</b>	1
<b>Switching mode</b>	Light/dark switching
<b>Switching mode selector</b>	Selectable via menu
<b>Output current I<sub>max.</sub></b>	≤ 100 mA
<b>Response time</b>	≤ 250 μs <sup>3)</sup> ≤ 50 μs, Selectable via menu <sup>3)</sup>
<b>Switching frequency</b>	2 kHz 10 kHz
<b>Time functions</b>	On delay Off delay One shot Without time delay
<b>Delay time</b>	Programmable, 0 ms ... 9,999 ms
<b>Input</b>	Teach-in input
<b>Connection type</b>	Male connector M8, 4-pin
<b>Cable material</b>	PVC
<b>Conductor cross-section</b>	0.2 mm <sup>2</sup>
<b>Cable diameter</b>	3.8 mm
<b>Circuit protection</b>	A <sup>4)</sup> B <sup>5)</sup> C <sup>6)</sup> D <sup>7)</sup>
<b>Protection class</b>	III
<b>Weight</b>	22 g
<b>Housing material</b>	Plastic, PC/POM
<b>Tightening torque, max.</b>	0.5 Nm
<b>Enclosure rating</b>	IP66 <sup>8)</sup>
<b>Ambient operating temperature</b>	-25 °C ... +55 °C
<b>Ambient storage temperature</b>	-40 °C ... +70 °C
<b>UL File No.</b>	NRKH2.E300503 & NRKH8.E300503

<sup>1)</sup> Limit values.

<sup>2)</sup> May not exceed or fall below U<sub>v</sub> tolerances.

<sup>3)</sup> Signal transit time with resistive load.

<sup>4)</sup> A = V<sub>S</sub> connections reverse-polarity protected.

<sup>5)</sup> B = inputs and output reverse-polarity protected.

<sup>6)</sup> C = interference suppression.

<sup>7)</sup> D = outputs overcurrent and short-circuit protected.

<sup>8)</sup> With correctly attached fibre-optic cable LL3.

## Safety-related parameters

<b>MTTF<sub>D</sub></b>	300 years
-------------------------	-----------

<b>DC<sub>avg</sub></b>	0%
-------------------------	----

### Classifications

<b>ECl@ss 5.0</b>	27270905
<b>ECl@ss 5.1.4</b>	27270905
<b>ECl@ss 6.0</b>	27270905
<b>ECl@ss 6.2</b>	27270905
<b>ECl@ss 7.0</b>	27270905
<b>ECl@ss 8.0</b>	27270905
<b>ECl@ss 8.1</b>	27270905
<b>ECl@ss 9.0</b>	27270905
<b>ECl@ss 10.0</b>	27270905
<b>ECl@ss 11.0</b>	27270905
<b>ETIM 5.0</b>	EC002651
<b>ETIM 6.0</b>	EC002651
<b>ETIM 7.0</b>	EC002651
<b>UNSPSC 16.0901</b>	39121528

### Connection diagram

Cd-092

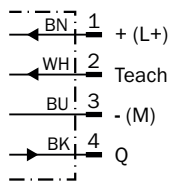

### Adjustments

GLL170T

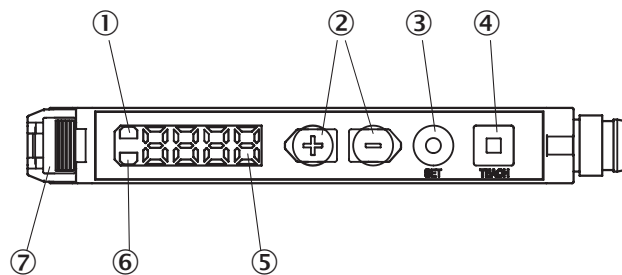

- ① LED indicator orange, lights up when switching output is active
- ② Plus/minus button
- ③ SET button
- ④ Teach-in button
- ⑤ Display
- ⑥ LED indicator green: Supply voltage active
- ⑦ Locking the fiber-optic cables

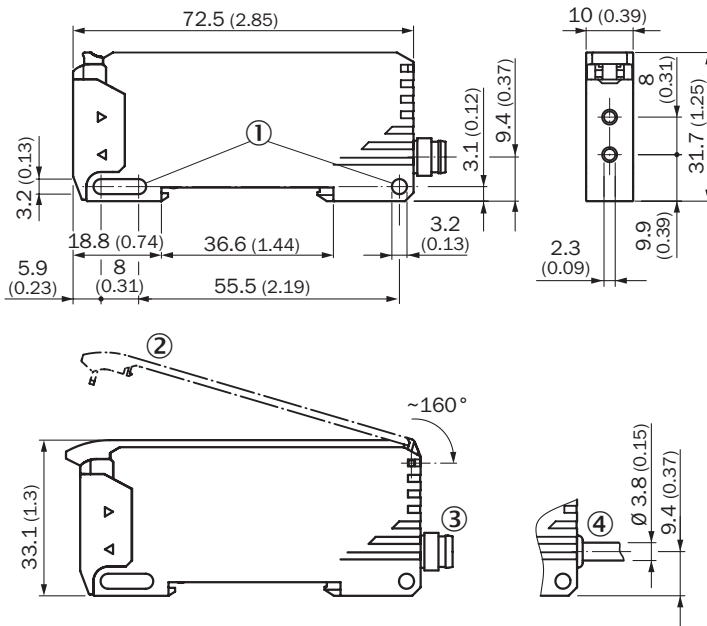

**Dimensional drawing** (Dimensions in mm (inch))



- ① Mounting holes
- ② Protective hood (optional), opens approx. 160°
- ③ Connector M8
- ④ Cable

**Recommended accessories**

Other models and accessories → [www.sick.com/GLL170](http://www.sick.com/GLL170)

	Brief description	Type	Part no.
<b>Device protection (mechanical)</b>			
	Protective Hood for GLL170, opens approx. 160°, PC	BF-GLL170	5336263
<b>Mounting brackets and plates</b>			
	Mounting bracket, steel, zinc coated, without mounting hardware	BEF-WLL180	5325812

	Brief description	Type	Part no.
<b>Fibers</b>			
	LL3-DB01	LL3-DB01	5308074
	LL3-DB02	LL3-DB02	5308083
	LL3-DC38	LL3-DC38	5322472
	LL3-DR11	LL3-DR11	5326000
	LL3-DT01	LL3-DT01	5308076
	LL3-DV05	LL3-DV05	5322549
	LL3-TB01	LL3-TB01	5308050
	LL3-TH08	LL3-TH08	5325978
	LL3-TS40	LL3-TS40	5323971
	LL3-TV05	LL3-TV05	5322546
	LL3-TX01	LL3-TX01	5324173
	LL3-TY01	LL3-TY01	5308066
<b>Plug connectors and cables</b>			
	Head A: female connector, M8, 4-pin, straight, A-coded Head B: Flying leads Cable: Sensor/actuator cable, PVC, unshielded, 2 m	YF8U14-020VA3XLEAX	2095888
	Head A: female connector, M8, 4-pin, straight, A-coded Head B: Flying leads Cable: Sensor/actuator cable, PVC, unshielded, 5 m	YF8U14-050VA3XLEAX	2095889
	Head A: female connector, M8, 4-pin, straight, A-coded Head B: Flying leads Cable: Sensor/actuator cable, PVC, unshielded, 10 m	YF8U14-100VA3XLEAX	2095890
	Head A: female connector, M8, 4-pin, angled, A-coded Head B: Flying leads Cable: Sensor/actuator cable, PVC, unshielded, 2 m	YG8U14-020VA3XLEAX	2095962
	Head A: female connector, M8, 4-pin, angled, A-coded Head B: Flying leads Cable: Sensor/actuator cable, PVC, unshielded, 5 m	YG8U14-050VA3XLEAX	2095963
	Head A: female connector, M8, 4-pin, angled, A-coded Head B: Flying leads Cable: Sensor/actuator cable, PVC, unshielded, 10 m	YG8U14-100VA3XLEAX	2095964
	Head A: female connector, M8, 4-pin, straight Head B: - Cable: unshielded	DOS-0804-G	6009974
	Head A: female connector, M8, 4-pin, angled Head B: - Cable: unshielded	DOS-0804-W	6009975
	Head A: male connector, M8, 4-pin, straight Head B: - Cable: unshielded	STE-0804-G	6037323



## SICK AT A GLANCE

SICK is one of the leading manufacturers of intelligent sensors and sensor solutions for industrial applications. A unique range of products and services creates the perfect basis for controlling processes securely and efficiently, protecting individuals from accidents and preventing damage to the environment.

We have extensive experience in a wide range of industries and understand their processes and requirements. With intelligent sensors, we can deliver exactly what our customers need. In application centers in Europe, Asia and North America, system solutions are tested and optimized in accordance with customer specifications. All this makes us a reliable supplier and development partner.

Comprehensive services complete our offering: SICK LifeTime Services provide support throughout the machine life cycle and ensure safety and productivity.

For us, that is “Sensor Intelligence.”

## WORLDWIDE PRESENCE:

Contacts and other locations –[www.sick.com](http://www.sick.com)

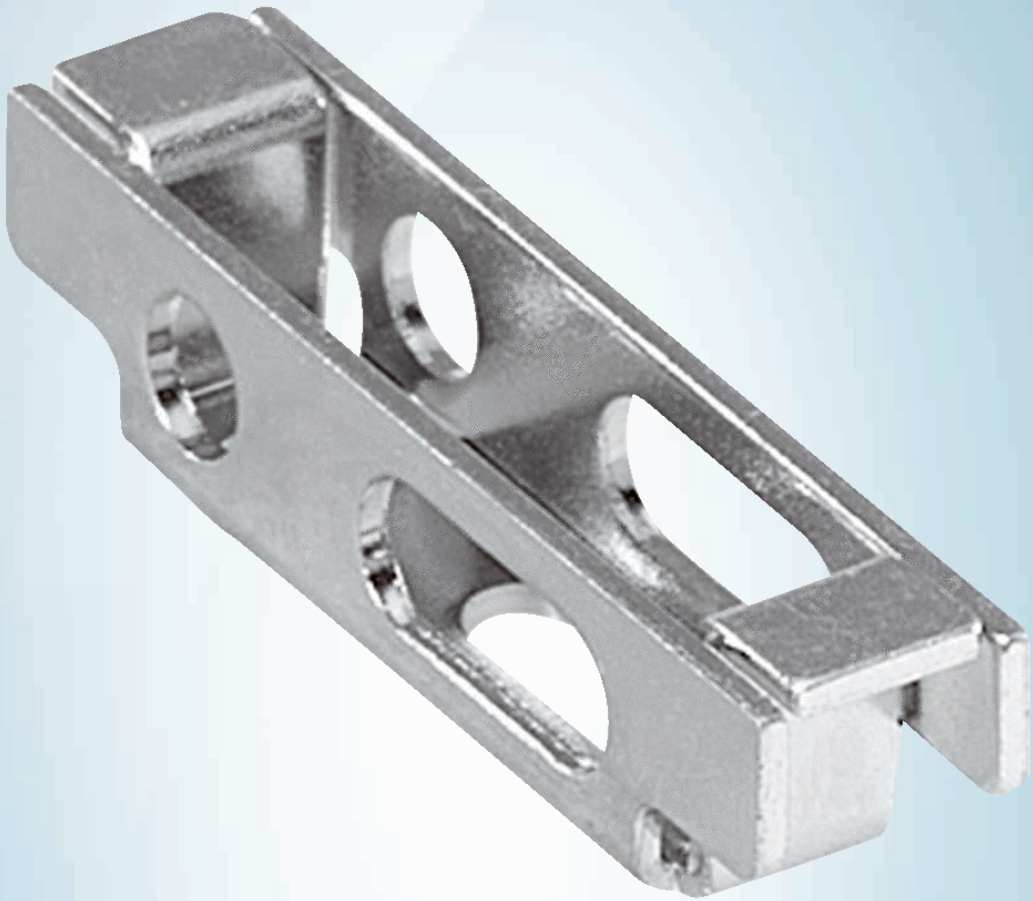

BEF-WLL180

**SICK**  
Sensor Intelligence.

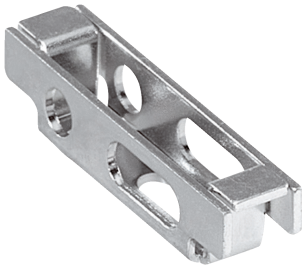

## Ordering information

Type	Part no.
BEF-WLL180	5325812

Other models and accessories → [www.sick.com/](http://www.sick.com/)

## Detailed technical data

### Technical specifications

<b>Accessory group</b>	Mounting brackets and plates
<b>Accessory family</b>	Mounting brackets
<b>Suitable for</b>	WLL180T, GLL170(T)
<b>Material</b>	Steel, zinc coated
<b>Items supplied</b>	Without mounting hardware
<b>Description</b>	Mounting bracket

### Classifications

<b>ECl@ss 5.0</b>	27279202
<b>ECl@ss 5.1.4</b>	27279202
<b>ECl@ss 6.0</b>	27279202
<b>ECl@ss 6.2</b>	27279202
<b>ECl@ss 7.0</b>	27279202
<b>ECl@ss 8.0</b>	27279202
<b>ECl@ss 8.1</b>	27279202
<b>ECl@ss 9.0</b>	27273701
<b>ECl@ss 10.0</b>	27273701
<b>ECl@ss 11.0</b>	27273701
<b>ETIM 5.0</b>	EC002615
<b>ETIM 6.0</b>	EC002615
<b>ETIM 7.0</b>	EC002615
<b>UNSPSC 16.0901</b>	32131023

Dimensional drawing (Dimensions in mm (inch))

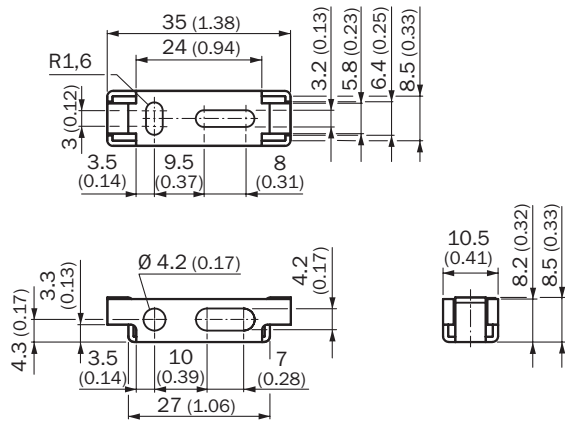

## SICK AT A GLANCE

SICK is one of the leading manufacturers of intelligent sensors and sensor solutions for industrial applications. A unique range of products and services creates the perfect basis for controlling processes securely and efficiently, protecting individuals from accidents and preventing damage to the environment.

We have extensive experience in a wide range of industries and understand their processes and requirements. With intelligent sensors, we can deliver exactly what our customers need. In application centers in Europe, Asia and North America, system solutions are tested and optimized in accordance with customer specifications. All this makes us a reliable supplier and development partner.

Comprehensive services complete our offering: SICK LifeTime Services provide support throughout the machine life cycle and ensure safety and productivity.

For us, that is “Sensor Intelligence.”

## WORLDWIDE PRESENCE:

Contacts and other locations –[www.sick.com](http://www.sick.com)

## SCISSORS LIFT DBNA

v1

2013/01/23

Designed for the mechanization and automation of various transport and loading/unloading operations as well as for work in technological lines. They are characterized by strengthened construction destined for a very harsh work environment. Made for lifting capacities of up to 8t and with a wide range of table dimensions depending on the requirements.



### TECHNICAL AND OPERATIONAL DATA:

		DBNA - 1,5t	DBNA - 2,5t	DBNA - 5,0t	DUO - 8,0t
Lifting capacity	t	1,5	2,5	5,0	8,0
Table dimensions (standard)	mm	2000 x 900	2500 x 1000	2800 x 1200	2200 x 5600
Table lifting time	s	47	32	37	75
Maximum lifting height	mm	1100	1600	1650/1750	1500
Height when folded	mm	250	300	400	400
Drive power	kW	1,1	4,0	5,5	7,5
Electric supply	V AC	3/N/PE, 400V 50Hz			
Control voltage	dBA	72-82 (depending on the used pump)			
Mass	kg	650	900	1330	2800

**The lift can be equipped with roller conveyors, a rotating table, barriers, flaps, and other mechanisms, offered in a wide range of table dimensions and lifting heights depending on the client's needs.**

*Lifts are inspected according to appendix C of the PN-EN 1570:2002 standard – "SAFETY REQUIREMENTS REGARDING TABLE LIFTS", and have a CE COMPLIANCE DECLARATION and all necessary documents for UDT registration.*

# IRB 760

## Industrial Robot



The 4-axis robot can move and rotate large and heavy products at high speeds, and with the utmost care. Its compact design makes it ideal for fitting into existing lines.

### Shorter cycle times

The IRB 760 is the fastest robot of its kind and is capable of significantly shortening cycle times and raising productivity for full-layer palletizing and press tending. This four-axis robot has a reach of 3.2 meters and a 450 kilograms payload capacity, enabling it to lift heavy objects and full pallet layers. With its high torque wrist and long reach it can achieve 880 cycles per hour at full load (400 mm, 2000 mm, 400 mm cycle).

### IRB 760PT press tending robot

Aimed at press automation applications in the automotive industry, the IRB 760PT is a flexible press tending robot offering 25 per cent faster cycle times compared to other robot-based press automation solutions. Its 3.18 meter reach, coupled with a linear seventh axis or with the Twin Xbar system avoids the need to reorient parts between consecutive stamping operations, helping users to optimize available space and save costs.

### High precision movements

Utilizing ABB's patented motion control software, QuickMove™ and TrueMove™, the IRB 760 family ensures palletizing and press tending is carried out with smooth movements and high path accuracy. This means even the most sensitive products will be handled with great care without losing cycle time.

### Low cost of ownership and increased productivity

The robot's robust and rigid design – manufactured to automotive industry standards – ensures high uptime and low maintenance costs. The IRB 760 family also features integrated process cabling which helps extend life and reduces wear.

The IRB 760 family is also covered by Robot Care, a warranty package that includes ABB's Connected Services, where ABB experts can monitor robots and suggest optimized the robot's performance thru advance services to further increase productivity and maintain high OEE.

Offline programming is the best way to maximize return on investment for robot systems. ABB's simulation and offline programming software, RobotStudio, allows robot programming to be done on a PC in the office without shutting down production. RobotStudio provides the tools to increase the profitability of your robot system by letting you perform tasks such as training, programming, and optimization without disturbing production.

### Main applications

- Full layer palletizing
- Palletizing
- Depalletizing
- Material handling
- Press tending



## Specification

Robot version	Reach (m)	Handling capacity (kg)
IRB 760	3.18	450
IRB 760PT	3.18	450
Number of axes	4	
Protection	IP67	
Mounting	Floor mounted	
Controller	IRC5 Single cabinet, IRC5 Dual cabinet	
Integrated power signal supply	Optional	
Integrated air supply	Optional	

## Performance (according to ISO 9283)

	Position repeatability RP (mm)	Path repeatability RT (mm)
IRB 760	0.05	0.80

## Cycles per hour

	Load (kg)	Cycles per hour
IRB 760	60	450

## Technical information

### Electrical Connections

Supply voltage	200-600 V, 50-60 Hz
Power consumption	ISO cube 2.75 kW

### Physical

Dimensions robot base	1140 x 800 mm
Robot weight	2310 kg

### Environment

Ambient temperature for mechanical unit	
During operation	+ - 0°C (32°F) to + 50°C (122°F)
During transportation and storage	-25° C (-13° F) to +55° C (131° F)
For short periods (max 24 h) up to	+70° C (158° F)

Relative humidity	Max. 95%
Noise level	< 70 dB (A)
Safety	Double circuits with supervisions, emergency stops and safety functions. 3-position enable device

Emission	EMC/EMI shielded
----------	------------------

Data and dimensions may be changed without notice.

## IRB 760

Axis movement	Working range	Axis max speed
Axis 1	+180° to -180°	85°/s
Axis 2	+85° to -42°	85°/s
Axis 3	+120° to -20°	85°/s
Axis 4*	+300° to -300°	160°/s

\* +67 rev. to - 67 rev. max

## IRB 760, working range

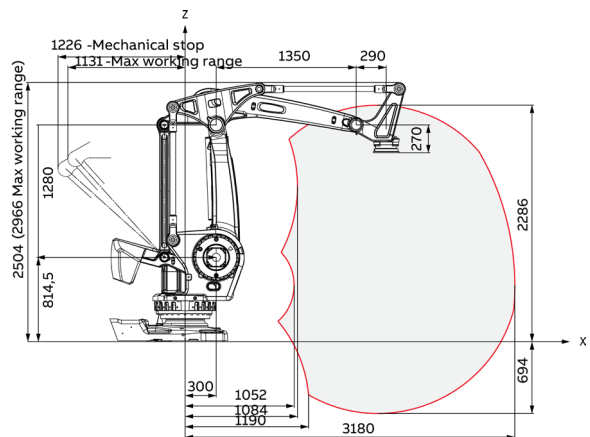

## IRB 760PT, working range

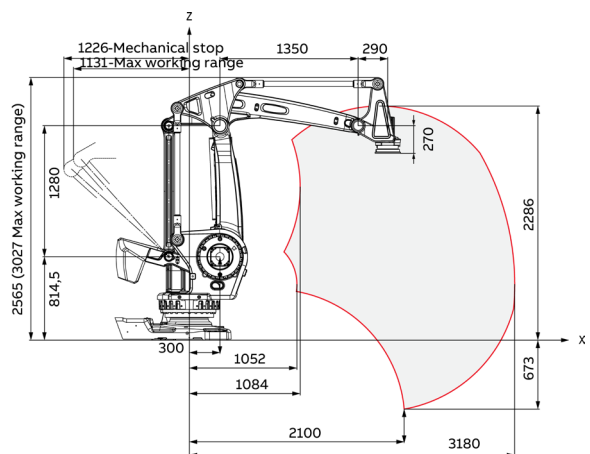

## IRB 760PT, In press automation applications

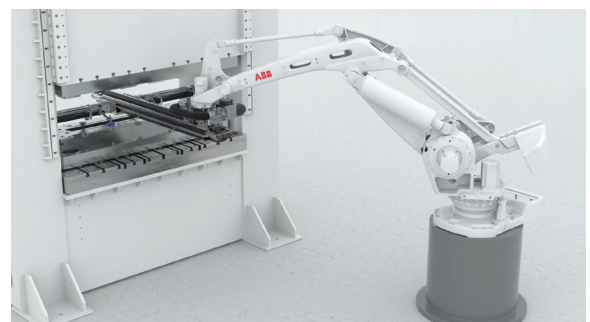

The IRB 760FX is a combination of an IRB 760PT and a Linear 7th axis.

## KENOS®KVG120

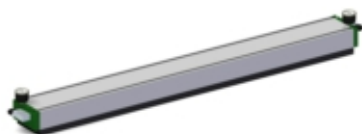

- ▶ The KVG (Kenos vacuum gripper) gripping system can be equipped with integrated COAX® cartridges or connector for external vacuum source.
- ▶ The KVG is available with different hole pattern and thickness of foam depending of the application requirements.
- ▶ Check valves require smaller vacuum pump and still maintain the vacuum level even if the whole surface of the gripper is not covered. Different recommended check valves for different porosities of handled material.
- ▶ Three-stage COAX® cartridge - MIDI - with extra high initial vacuum flow. Large vacuum flow in relation to energy consumption. State-of-the-art ejector technology inside.
- ▶ FDA approved foam in silicone available as an option.

### Technical data

Description	Unit	Value
Feed pressure, max.	psi	101.5
Temperature range	°F	32-122
Weight	lb	21-26
Material	-	Al, EPDM, NBR
Noise level	dBA	70
Connection, compressed air	-	G 1/4"

### Technical data, electrical solenoid valve

Description	Unit	Value
Operating pressure range	psi	0.15-0.7
Current consumption	mA	34
Supply voltage	VDC	24 (21.6 – 26.4)
Electrical connection	-	M8 3 pole male connector
Allowable voltage	-	± 10% rated voltage
Manual override	-	Push-locking slotted style
Impact / Vibration resistance	m/s <sup>2</sup>	150/30
Coil rated voltage	Vcc	Coil rated voltage
Surge voltage suppressor	-	Diode
Indicator light		LED

### Technical data, foam

Description	Unit	Value
Material	-	EPDM

### Vacuum flow

Feed pressure pump / nozzle	Air consumption per pump scfm	Vacuum flow (scfm) at different vacuum levels (-inHg)								Max vacuum -inHg
		0	3	6	9	12	15	18	21	
87.0	3.71	101.6	59.36	44.08	28.8	15.28	10.16	8.48	5.92	22.1

### Gripping force data

Force, lbf, at different vacuum levels (-inHg) , gripper with foam				
8.9	11.8	14.8	17.7	20.7
205	273.4	341.7	410.1	478.4

*Theoretic gripping force on rigid and stable surface with completely covered module, without safety factor.*

### Values specified in data sheet are tested at:

- Room temperature (20°C [68°F] ± 3°C [5.5°F]).
- Standard atmosphere (101.3 [29.9 inHg] ± 1.0 kPa [0.3 inHg]).
- Relative humidity 20-70%.
- Compressed air quality, DIN ISO 8573-1 class 4.

### Dimensional drawing

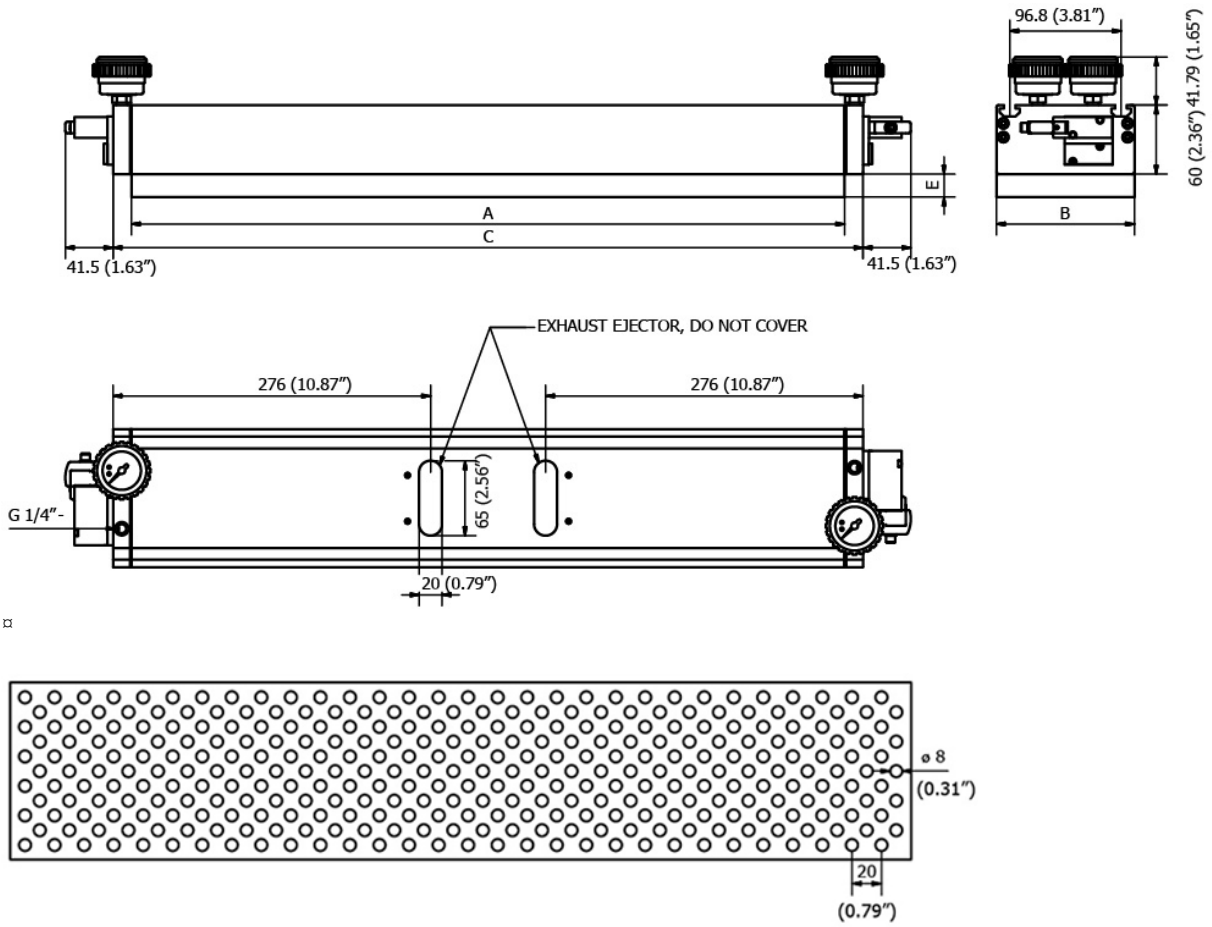

	mm [in]
A	1,110 [43.70"]
B	120 [4.72"]
C	1,142 [44.96"]
E	20 [0.79"]

Pneumatic diagram

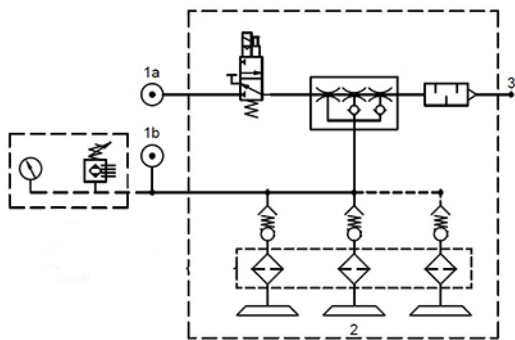

Please note that manometer and digital vacuum switch is optional and that the filter is only valid for KVG60 version comprising foam with filter.

**Ordering information**

Description	Product code
KENOS®KVG 1100 mm, 120 mm, Foam, 20 mm, With filter, Extra fine step, Check Valves Low flow, 8 cartridge Si32-3, EV vacuum N.C., Vacuum gauge	KVG.1100.120.N216.CVL.S8.V1.M3

**Ordering information, spare part foam**

Description	Product code
FOAM KVG 1100 mm, 120 mm, Foam, 20 mm, With filter, Extra fine step	FOAM.KVG.1100.120.N216

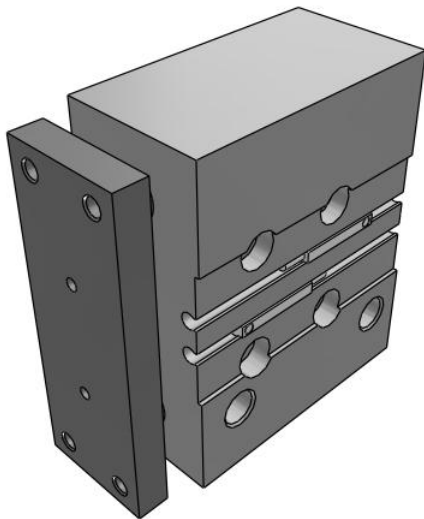

## MGP-Z, Compact Guide Cylinder MGPM20TF-30Z-M9B

### Datasheet

- 3 types of bearing can be selected: slide bearing, ball bushing and high precision ball bushing.
- Compactness & Lightness
- Bore size: 12, 16, 20, 25, 32, 40, 50, 63, 80, 100 (mm)
- Strokes from 10 to 400mm (depending upon bore size)
- 4 types of mounting are possible: top mounting, side mounting, bottom mounting and T-slot side mounting.
- Auto switches can be mounted on 2 surfaces.

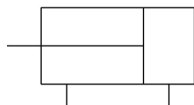

Double-acting, single-rod cylinder

### Standard specifications

Bearing Type	M (Slide Bearing)
Bore Size	Ø20 mm
Port Thread Type	TF [G]
Lube-retainer	Without Stable Lubrication Function
Stroke	30
Auto Switch	M9B--Solid State, Gen. Purpose, 2 Wire, Horizontal
Lead Wire Length	0.5m [Or None in the Case of No Switch]
Number of Auto Switches	2 pcs. [Or None in Case of No Switch]
Change of Guide Rod End Shape	None
Temperature Resistance	None
Low Speed	None
Fluororubber Seal	None
Grease for Food Processing Equipment	None
Pressure medium	Compressed air
Maximum temperature of pressure medium	60 °C
Minimum temperature of pressure medium	-10 °C (No freezing)
Maximum operating pressure	1.0 MPa
Minimum operating pressure	0.1 MPa

Proof pressure	1.5 MPa
Maximum ambient temperature	60 °C
Minimum ambient temperature	-10 °C (No freezing)
Number of pneumatic connections	4 pcs.
Pneumatic input connection	G 1/8
Pneumatic exhaust connection	G 1/8
Mode of operation of drive	Double acting
Theoretical cylinder force, advance stroke (at 0.5 MPa)	157 N
Theoretical cylinder force, return stroke (at 0.5 MPa)	118 N
Maximum piston speed	500 mm/s
Type of cushioning	Rubber bumper on both ends
Non-rotating accuracy of plate	± 0.06 °
Weight	0.639 Kg



# Dimensions

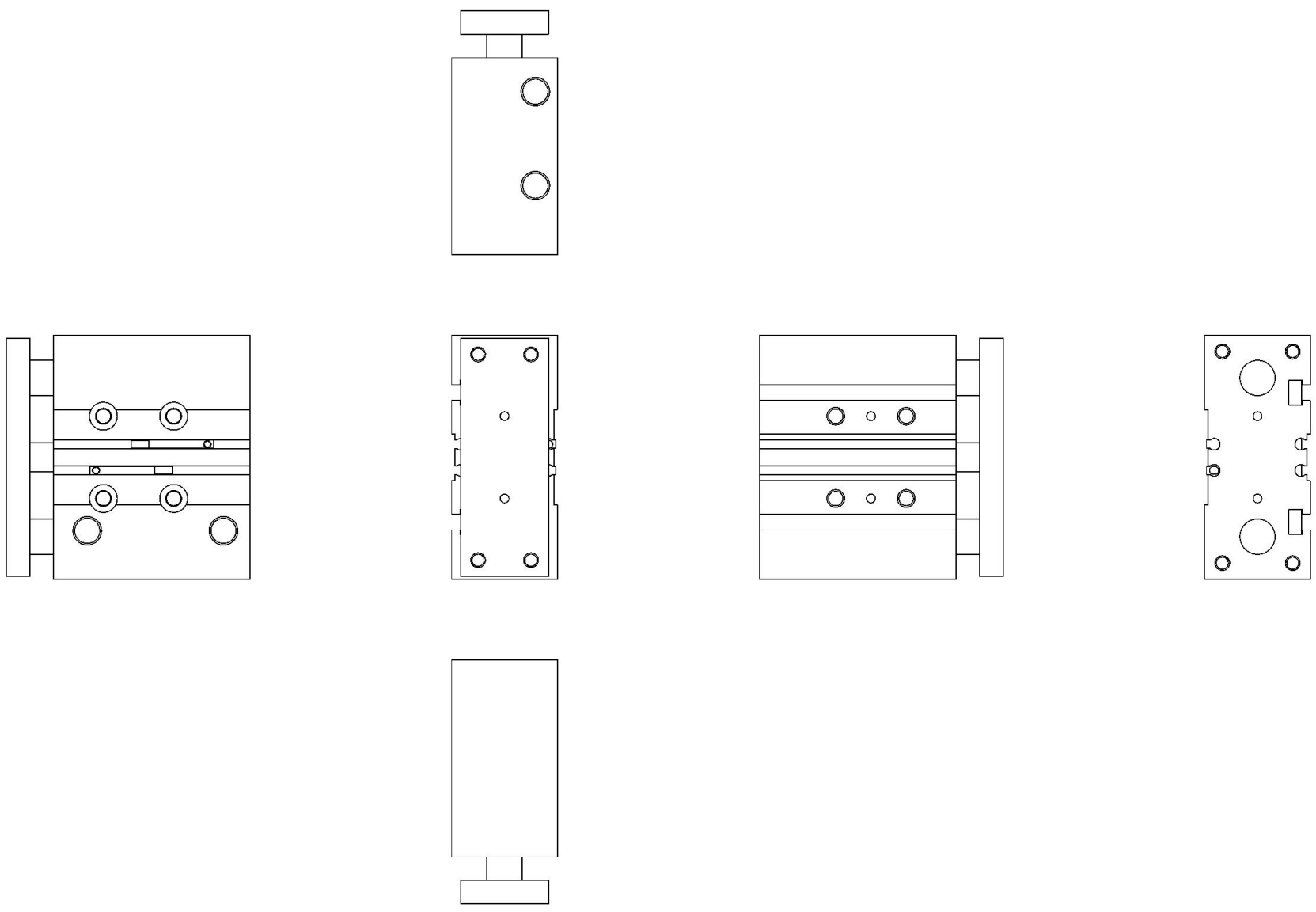

## Constructions

### MGPM12 to 25

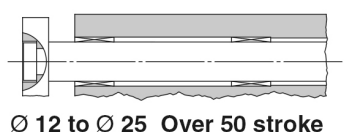
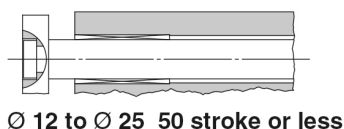
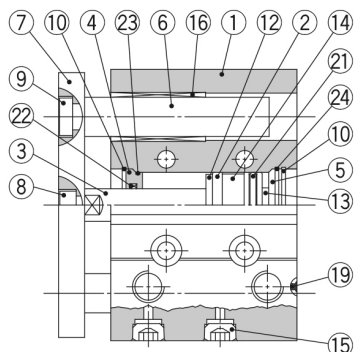

### MGPM32 to 100

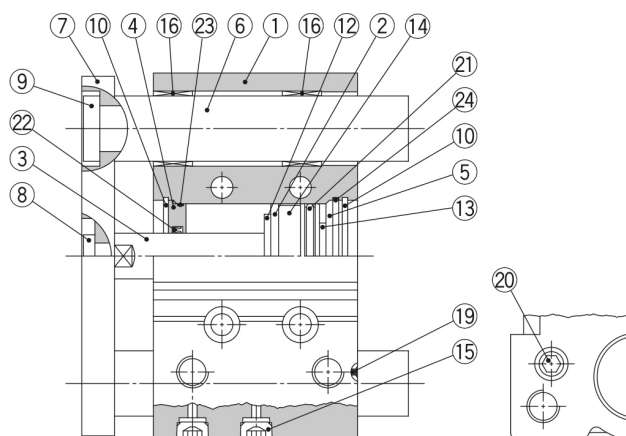

Ø 63 or more

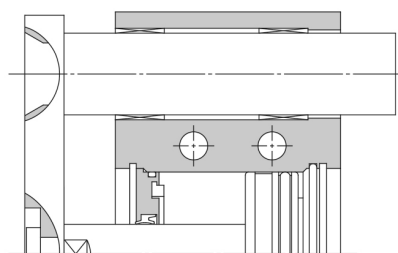

#### Component Parts

No.	Description	Material	Note
1	Body	Aluminium alloy	Hard anodised
2	Piston	Aluminium alloy	
3	Piston rod	Stainless steel Carbon steel	Ø 12 to Ø 25 Ø 32 to Ø 100   Hard chrome plating
4	Collar	Aluminium alloy	Chromated
5	Head cover	Aluminium alloy	Ø 12 to Ø 63   Chromated Ø 80, Ø 100   Painted
6	Guide rod	Carbon steel	Hard chrome plating
7	Plate	Carbon steel	Nickel plating
8	Plate mounting bolt	Carbon steel	Nickel plating
9	Guide bolt	Carbon steel	Nickel plating
10	Retaining ring	Carbon tool steel	Phosphate coated
11	Retaining ring	Carbon tool steel	Phosphate coated
12	Bumper A	Urethane	
13	Bumper B	Urethane	
14	Magnet	—	
15	Plug Hexagon socket head plug	Carbon steel	Ø 12, Ø 16 Ø 20 to Ø 100   Nickel plating
16	Slide bearing	Bearing alloy	

\*: A felt is not installed on the slide bearing.

#### Component Parts

No.	Description	Material	Note
17	Ball bushing		
18	Spacer	Aluminium alloy	
19	Steel ball	Carbon steel	Ø 12 to Ø 50
20	Plug	Carbon steel	Ø 63 to Ø 100   Nickel plating
21*	Piston seal	NBR	
22*	Rod seal	NBR	
23*	Gasket A	NBR	
24*	Gasket B	NBR	

#### Replacement Parts/Seal Kit

Bore size [mm]	Kit no.	Contents	Bore size [mm]	Kit no.	Contents
12	MGP12-Z-PS	Set of nos.	40	MGP40-Z-PS	Set of nos.
16	MGP16-Z-PS		50	MGP50-Z-PS	
20	MGP20-Z-PS	above	63	MGP63-Z-PS	above
25	MGP25-Z-PS	②①, ②②,	80	MGP80-Z-PS	②①, ②②,
32	MGP32-Z-PS	②③, ②④	100	MGP100-Z-PS	②③, ②④

\*: Seal kit includes ②① to ②④. Order the seal kit, based on each bore size.

\*: Since the seal kit does not include a grease pack, order it separately.

Grease pack part number: GR-S-010 (10 g)

## Additional information

Catalogue

[MGP-Z-Dd\\_EU.pdf](#)

Operation manuals

[OM\\_MGP-Z\\_MGPx-OM0047PEN-B.pdf](#)

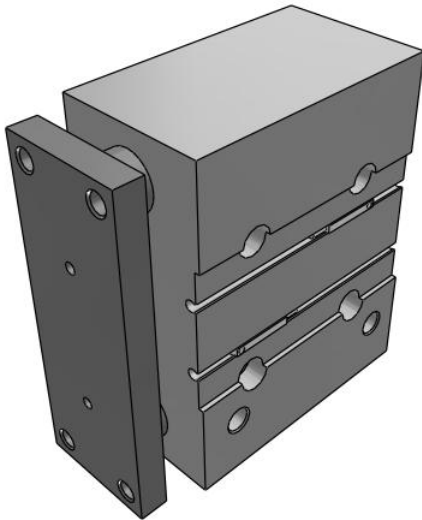

## MGP-Z, Compact Guide Cylinder MGPM40TF-30Z-M9B

### Datasheet

- 3 types of bearing can be selected: slide bearing, ball bushing and high precision ball bushing.
- Compactness & Lightness
- Bore size: 12, 16, 20, 25, 32, 40, 50, 63, 80, 100 (mm)
- Strokes from 10 to 400mm (depending upon bore size)
- 4 types of mounting are possible: top mounting, side mounting, bottom mounting and T-slot side mounting.
- Auto switches can be mounted on 2 surfaces.

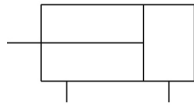

Double-acting, single-rod cylinder

### Standard specifications

Bearing Type	M (Slide Bearing)
Bore Size	Ø40 mm
Port Thread Type	TF [G]
Lube-retainer	Without Stable Lubrication Function
Stroke	30
Auto Switch	M9B--Solid State, Gen. Purpose, 2 Wire, Horizontal
Lead Wire Length	0.5m [Or None in the Case of No Switch]
Number of Auto Switches	2 pcs. [Or None in Case of No Switch]
Change of Guide Rod End Shape	None
Temperature Resistance	None
Low Speed	None
Fluororubber Seal	None
Grease for Food Processing Equipment	None
Pressure medium	Compressed air
Maximum temperature of pressure medium	60 °C
Minimum temperature of pressure medium	-10 °C (No freezing)
Maximum operating pressure	1.0 MPa
Minimum operating pressure	0.1 MPa

Proof pressure	1.5 MPa
Maximum ambient temperature	60 °C
Minimum ambient temperature	-10 °C (No freezing)
Number of pneumatic connections	4 pcs.
Pneumatic input connection	G 1/8
Pneumatic exhaust connection	G 1/8
Mode of operation of drive	Double acting
Theoretical cylinder force, advance stroke (at 0.5 MPa)	628 N
Theoretical cylinder force, return stroke (at 0.5 MPa)	551 N
Maximum piston speed	500 mm/s
Type of cushioning	Rubber bumper on both ends
Non-rotating accuracy of plate	± 0.05 °
Weight	0.000 Kg

# Dimensions

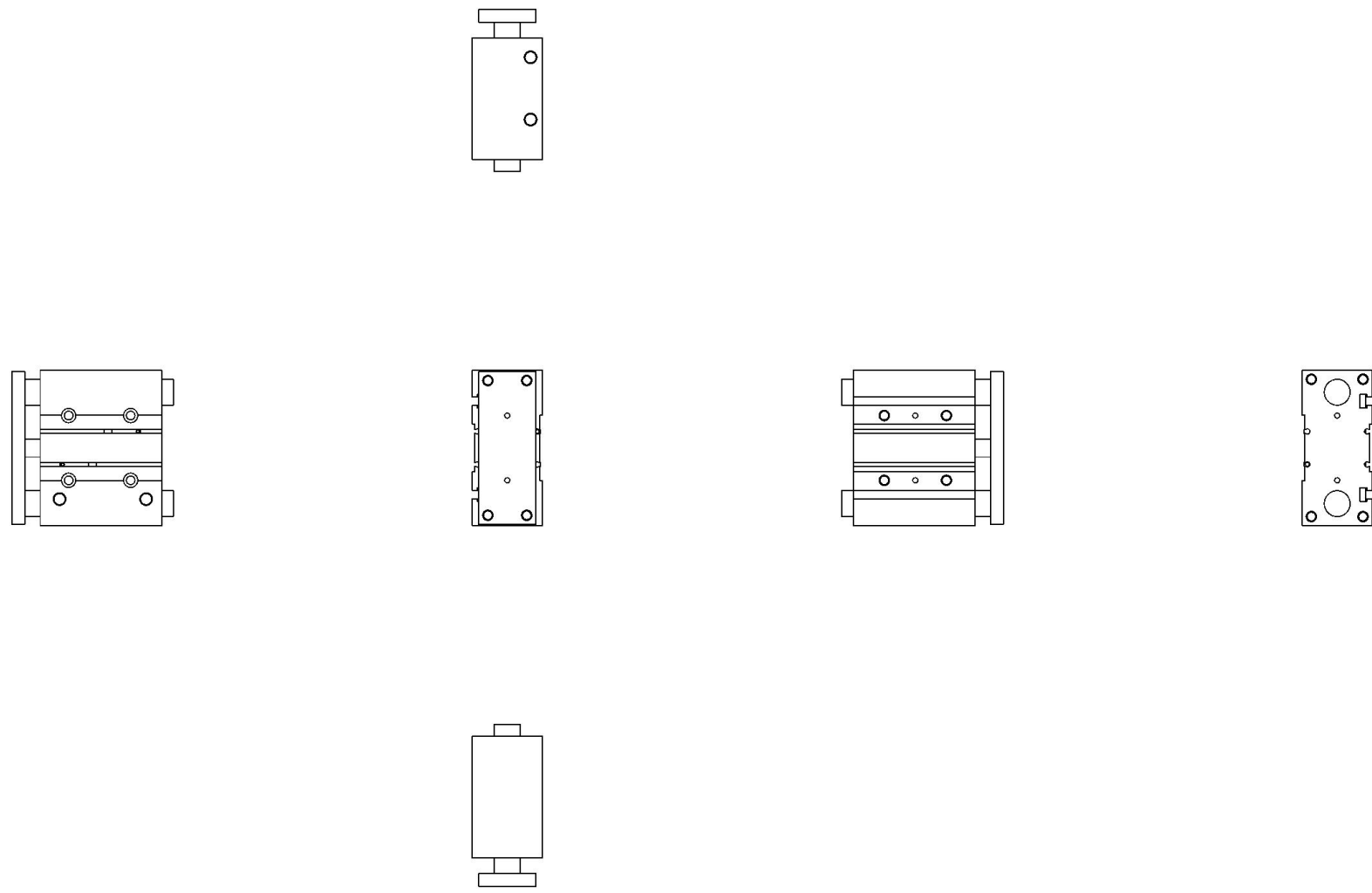

## Constructions

### MGPM12 to 25

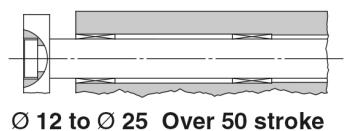
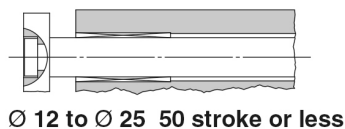
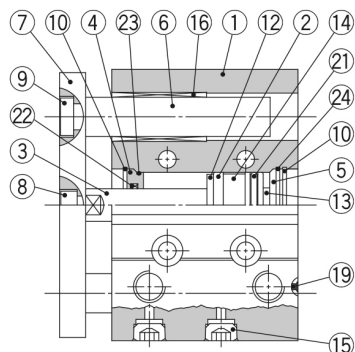

### MGPM32 to 100

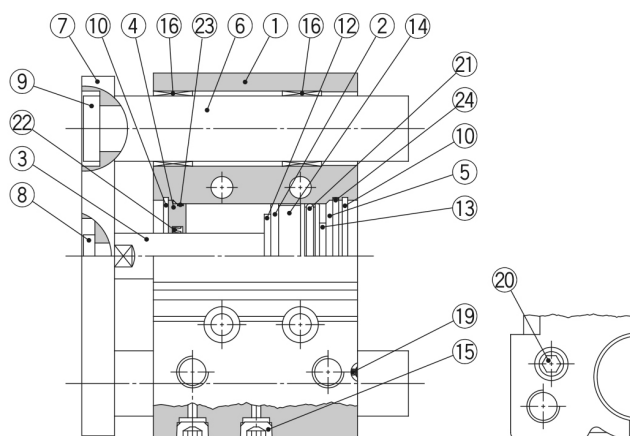

Ø 63 or more

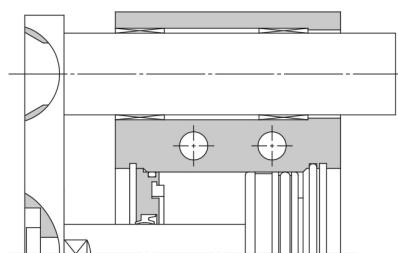

#### Component Parts

No.	Description	Material	Note
1	Body	Aluminium alloy	Hard anodised
2	Piston	Aluminium alloy	
3	Piston rod	Stainless steel	Ø 12 to Ø 25
		Carbon steel	Ø 32 to Ø 100   Hard chrome plating
4	Collar	Aluminium alloy	Chromated
5	Head cover	Aluminium alloy	Ø 12 to Ø 63   Chromated
			Ø 80, Ø 100   Painted
6	Guide rod	Carbon steel	Hard chrome plating
7	Plate	Carbon steel	Nickel plating
8	Plate mounting bolt	Carbon steel	Nickel plating
9	Guide bolt	Carbon steel	Nickel plating
10	Retaining ring	Carbon tool steel	Phosphate coated
11	Retaining ring	Carbon tool steel	Phosphate coated
12	Bumper A	Urethane	
13	Bumper B	Urethane	
14	Magnet	—	
15	Plug Hexagon socket head plug	Carbon steel	Ø 12, Ø 16   Nickel plating
			Ø 20 to Ø 100
16	Slide bearing	Bearing alloy	

\*: A felt is not installed on the slide bearing.

#### Component Parts

No.	Description	Material	Note
17	Ball bushing		
18	Spacer	Aluminium alloy	
19	Steel ball	Carbon steel	Ø 12 to Ø 50
20	Plug	Carbon steel	Ø 63 to Ø 100   Nickel plating
21*	Piston seal	NBR	
22*	Rod seal	NBR	
23*	Gasket A	NBR	
24*	Gasket B	NBR	

#### Replacement Parts/Seal Kit

Bore size [mm]	Kit no.	Contents	Bore size [mm]	Kit no.	Contents
12	MGP12-Z-PS	Set of nos.	40	MGP40-Z-PS	Set of nos. above
16	MGP16-Z-PS		50	MGP50-Z-PS	
20	MGP20-Z-PS	②①, ②②, ②③, ②④	63	MGP63-Z-PS	②①, ②②, ②③, ②④
25	MGP25-Z-PS		80	MGP80-Z-PS	
32	MGP32-Z-PS		100	MGP100-Z-PS	

\*: Seal kit includes ②① to ②④. Order the seal kit, based on each bore size.

\*: Since the seal kit does not include a grease pack, order it separately.

Grease pack part number: GR-S-010 (10 g)



## Additional information

Catalogue

[MGP-Z-Dd\\_EU.pdf](#)

Operation manuals

[OM\\_MGP-Z\\_MGPx-OM0047PEN-B.pdf](#)

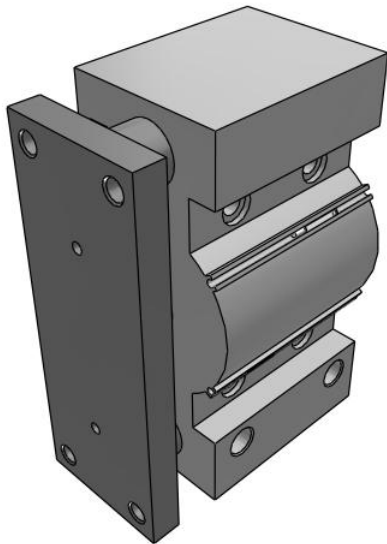

## MGP-Z, Compact Guide Cylinder MGPM80TF-30Z-M9B

### Datasheet

- 3 types of bearing can be selected: slide bearing, ball bushing and high precision ball bushing.
- Compactness & Lightness
- Bore size: 12, 16, 20, 25, 32, 40, 50, 63, 80, 100 (mm)
- Strokes from 10 to 400mm (depending upon bore size)
- 4 types of mounting are possible: top mounting, side mounting, bottom mounting and T-slot side mounting.
- Auto switches can be mounted on 2 surfaces.

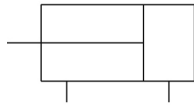

Double-acting, single-rod cylinder

### Standard specifications

Bearing Type	M (Slide Bearing)
Bore Size	Ø80 mm
Port Thread Type	TF [G]
Lube-retainer	Without Stable Lubrication Function
Stroke	30
Auto Switch	M9B--Solid State, Gen. Purpose, 2 Wire, Horizontal
Lead Wire Length	0.5m [Or None in the Case of No Switch]
Number of Auto Switches	2 pcs. [Or None in Case of No Switch]
Change of Guide Rod End Shape	None
Temperature Resistance	None
Low Speed	None
Fluororubber Seal	None
Grease for Food Processing Equipment	None
Pressure medium	Compressed air
Maximum temperature of pressure medium	60 °C
Minimum temperature of pressure medium	-10 °C (No freezing)
Maximum operating pressure	1.0 MPa
Minimum operating pressure	0.1 MPa

Proof pressure	1.5 MPa
Maximum ambient temperature	60 °C
Minimum ambient temperature	-10 °C (No freezing)
Number of pneumatic connections	4 pcs.
Pneumatic input connection	G 3/8
Pneumatic exhaust connection	G 3/8
Mode of operation of drive	Double acting
Theoretical cylinder force, advance stroke (at 0.5 MPa)	2513 N
Theoretical cylinder force, return stroke (at 0.5 MPa)	2323 N
Maximum piston speed	400 mm/s
Type of cushioning	Rubber bumper on both ends
Non-rotating accuracy of plate	± 0.03 °

# Dimensions

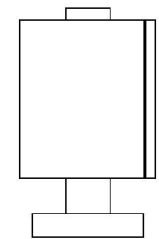
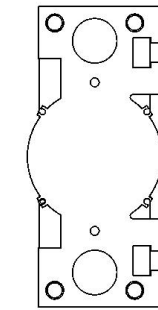
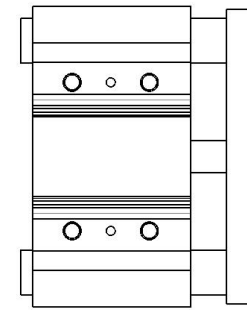
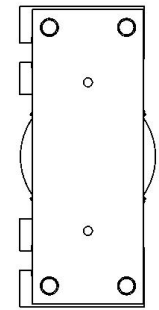
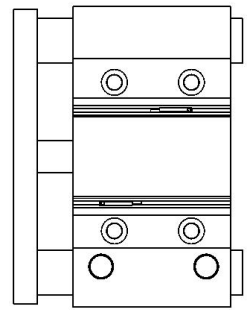
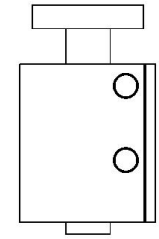

## Constructions

### MGPM12 to 25

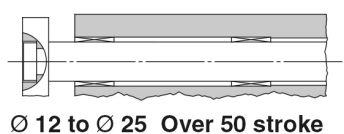
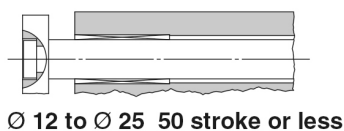
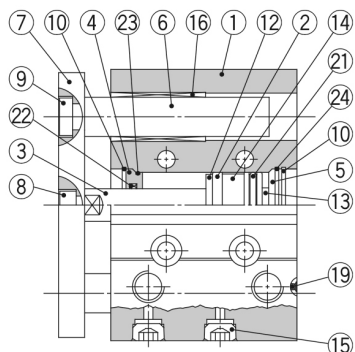

### MGPM32 to 100

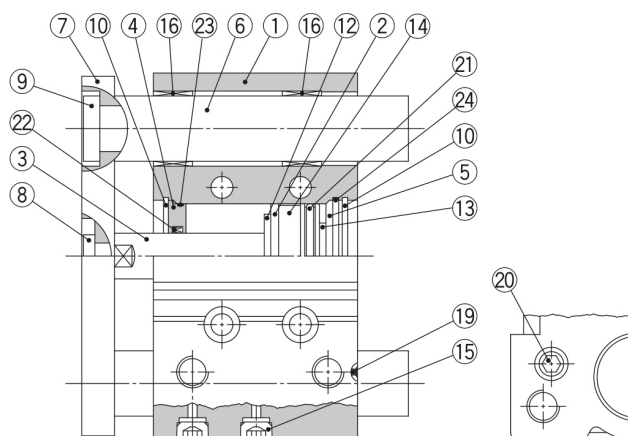

Ø 63 or more

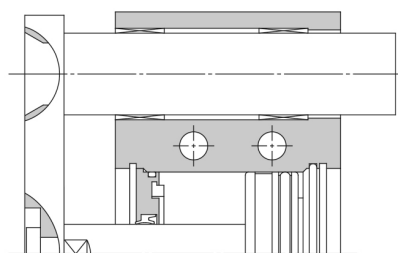

#### Component Parts

No.	Description	Material	Note
1	Body	Aluminium alloy	Hard anodised
2	Piston	Aluminium alloy	
3	Piston rod	Stainless steel Carbon steel	Ø 12 to Ø 25 Ø 32 to Ø 100   Hard chrome plating
4	Collar	Aluminium alloy	Chromated
5	Head cover	Aluminium alloy	Ø 12 to Ø 63   Chromated Ø 80, Ø 100   Painted
6	Guide rod	Carbon steel	Hard chrome plating
7	Plate	Carbon steel	Nickel plating
8	Plate mounting bolt	Carbon steel	Nickel plating
9	Guide bolt	Carbon steel	Nickel plating
10	Retaining ring	Carbon tool steel	Phosphate coated
11	Retaining ring	Carbon tool steel	Phosphate coated
12	Bumper A	Urethane	
13	Bumper B	Urethane	
14	Magnet	—	
15	Plug Hexagon socket head plug	Carbon steel	Ø 12, Ø 16 Ø 20 to Ø 100   Nickel plating
16	Slide bearing	Bearing alloy	

\*: A felt is not installed on the slide bearing.

#### Component Parts

No.	Description	Material	Note
17	Ball bushing		
18	Spacer	Aluminium alloy	
19	Steel ball	Carbon steel	Ø 12 to Ø 50
20	Plug	Carbon steel	Ø 63 to Ø 100   Nickel plating
21*	Piston seal	NBR	
22*	Rod seal	NBR	
23*	Gasket A	NBR	
24*	Gasket B	NBR	

#### Replacement Parts/Seal Kit

Bore size [mm]	Kit no.	Contents	Bore size [mm]	Kit no.	Contents
12	MGP12-Z-PS	Set of nos. above	40	MGP40-Z-PS	Set of nos. above
16	MGP16-Z-PS		50	MGP50-Z-PS	
20	MGP20-Z-PS	⑲, ⑳, ㉑, ㉒, ㉓, ㉔	63	MGP63-Z-PS	⑲, ⑳, ㉑, ㉒, ㉓, ㉔
25	MGP25-Z-PS		80	MGP80-Z-PS	
32	MGP32-Z-PS		100	MGP100-Z-PS	

\*: Seal kit includes ㉑) to ㉔). Order the seal kit, based on each bore size.

\*: Since the seal kit does not include a grease pack, order it separately.

Grease pack part number: GR-S-010 (10 g)

## Additional information

Catalogue

[MGP-Z-Dd\\_EU.pdf](#)

Operation manuals

[OM\\_MGP-Z\\_MGPx-OM0047PEN-B.pdf](#)

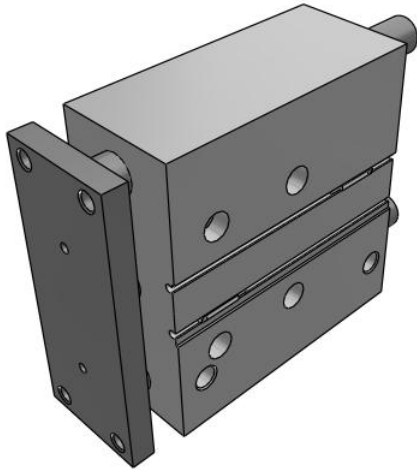

## MGP-Z, Compact Guide Cylinder MGPL50TF-100Z-M9B

### Datasheet

- 3 types of bearing can be selected: slide bearing, ball bushing and high precision ball bushing.
- Compactness & Lightness
- Bore size: 12, 16, 20, 25, 32, 40, 50, 63, 80, 100 (mm)
- Strokes from 10 to 400mm (depending upon bore size)
- 4 types of mounting are possible: top mounting, side mounting, bottom mounting and T-slot side mounting.
- Auto switches can be mounted on 2 surfaces.

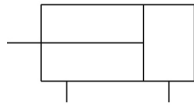

Double-acting, single-rod cylinder

### Standard specifications

Bearing Type	L (Ball Bushing Bearing)
Bore Size	Ø50 mm
Port Thread Type	TF [G]
Lube-retainer	Without Stable Lubrication Function
Stroke	100
Auto Switch	M9B--Solid State, Gen. Purpose, 2 Wire, Horizontal
Lead Wire Length	0.5m [Or None in the Case of No Switch]
Number of Auto Switches	2 pcs. [Or None in Case of No Switch]
Change of Guide Rod End Shape	None
Temperature Resistance	None
Low Speed	None
Fluororubber Seal	None
Grease for Food Processing Equipment	None
Pressure medium	Compressed air
Maximum temperature of pressure medium	60 °C
Minimum temperature of pressure medium	-10 °C (No freezing)
Maximum operating pressure	1.0 MPa
Minimum operating pressure	0.1 MPa



Proof pressure	1.5 MPa
Maximum ambient temperature	60 °C
Minimum ambient temperature	-10 °C (No freezing)
Number of pneumatic connections	4 pcs.
Pneumatic input connection	G 1/4
Pneumatic exhaust connection	G 1/4
Mode of operation of drive	Double acting
Theoretical cylinder force, advance stroke (at 0.5 MPa)	982 N
Theoretical cylinder force, return stroke (at 0.5 MPa)	855 N
Maximum piston speed	500 mm/s
Type of cushioning	Rubber bumper on both ends
Non-rotating accuracy of plate	± 0.03 °

# Dimensions

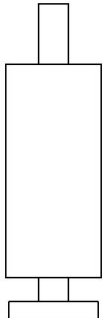
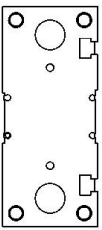
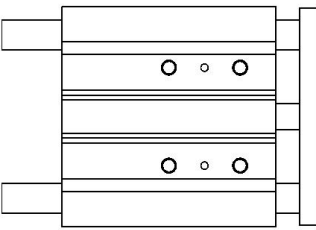
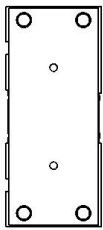
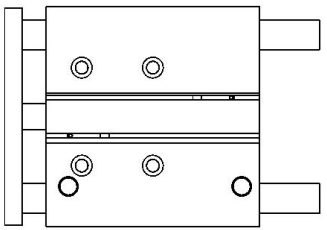
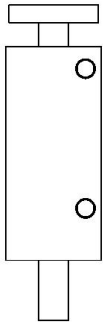

# Constructions

## MGPM12 to 25

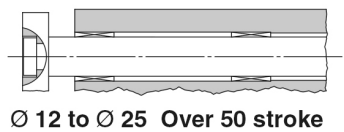
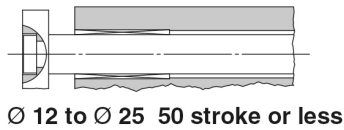
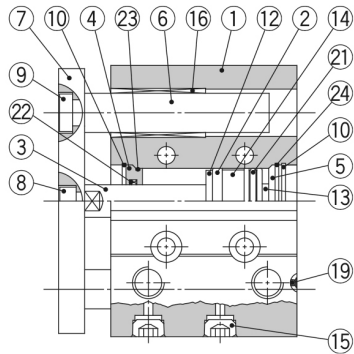

## MGPM32 to 100

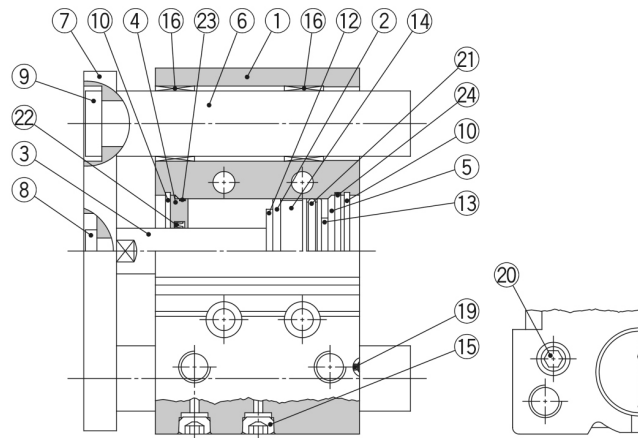

Ø 63 or more

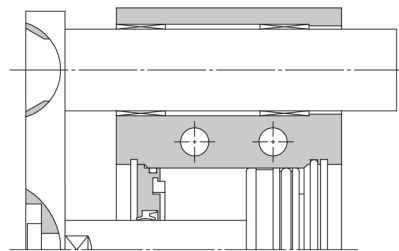

Ø 50 or more

### Component Parts

No.	Description	Material	Note
1	Body	Aluminium alloy	Hard anodised
2	Piston	Aluminium alloy	
3	Piston rod	Stainless steel	Ø 12 to Ø 25
		Carbon steel	Ø 32 to Ø 100   Hard chrome plating
4	Collar	Aluminium alloy	Chromated
5	Head cover	Aluminium alloy	Ø 12 to Ø 63   Chromated
			Ø 80, Ø 100   Painted
6	Guide rod	Carbon steel	Hard chrome plating
7	Plate	Carbon steel	Nickel plating
8	Plate mounting bolt	Carbon steel	Nickel plating
9	Guide bolt	Carbon steel	Nickel plating
10	Retaining ring	Carbon tool steel	Phosphate coated
11	Retaining ring	Carbon tool steel	Phosphate coated
12	Bumper A	Urethane	
13	Bumper B	Urethane	
14	Magnet	—	
15	Plug Hexagon socket head plug	Carbon steel	Ø 12, Ø 16   Nickel plating
			Ø 20 to Ø 100
16	Slide bearing	Bearing alloy	

\*: A felt is not installed on the slide bearing.

### Component Parts

No.	Description	Material	Note
17	Ball bushing		
18	Spacer	Aluminium alloy	
19	Steel ball	Carbon steel	Ø 12 to Ø 50
20	Plug	Carbon steel	Ø 63 to Ø 100   Nickel plating
21*	Piston seal	NBR	
22*	Rod seal	NBR	
23*	Gasket A	NBR	
24*	Gasket B	NBR	

### Replacement Parts/Seal Kit

Bore size [mm]	Kit no.	Contents	Bore size [mm]	Kit no.	Contents
12	MGP12-Z-PS	Set of nos. above	40	MGP40-Z-PS	Set of nos. above
16	MGP16-Z-PS		50	MGP50-Z-PS	
20	MGP20-Z-PS	⑳, ㉑, ㉒, ㉓, ㉔	63	MGP63-Z-PS	㉑, ㉒, ㉓, ㉔
25	MGP25-Z-PS		80	MGP80-Z-PS	
32	MGP32-Z-PS		100	MGP100-Z-PS	

\*: Seal kit includes ㉑) to ㉔). Order the seal kit, based on each bore size.

\*: Since the seal kit does not include a grease pack, order it separately.

Grease pack part number: GR-S-010 (10 g)

## Additional information

Catalogue

[MGP-Z-Dd\\_EU.pdf](#)

Operation manuals

[OM\\_MGP-Z\\_MGPx-OM0047PEN-B.pdf](#)

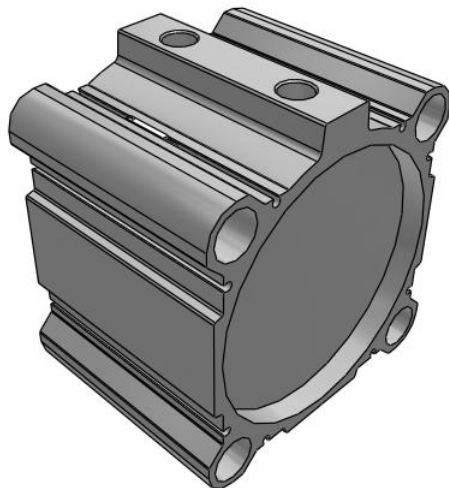

## C(D)Q2, Compact Cylinder, Double Acting, Single Rod, Large Bore w/Auto Switch Mounting Groove

### CDQ2B125TF-30DCZ-M9B

Datasheet

- Compact, double acting, single rod, large bore
- Bore sizes (mm): 125, 140, 160, 180, 200
- Standard stroke range (mm): 10 to 300
- Port threads: Rc, NPT, G
- Can mount small auto switches on 4 surfaces.

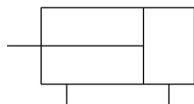

Double-acting, single-rod cylinder

## Standard specifications

Magnet	D (Built-in)
Bore Size	Ø125 mm
Port Thread Type	TF (G)
Stroke	30
Body Option	Standard (Rod End Female Thread)
Auto Switch	M9B--Solid State , Gen. Purpose, 2 Wire, Horizontal
Lead Wire or Prewired Connector	0.5 m or None in the Case of No Switch
Number	2 pcs.
Rod End Options	None
Fluororubber Seal	None
Pressure medium	Compressed air
Maximum temperature of pressure medium with magnet	60 °C
Minimum temperature of pressure medium with magnet	-10 °C
Maximum operating pressure	1.0 MPa
Minimum operating pressure	0.05 MPa
Proof pressure	1.5 MPa
Maximum ambient temperature with magnet	60 °C
Minimum ambient temperature with magnet	-10 °C
Conform to the European RoHS Directive	Conform

Number of pneumatic connections	2 pcs.
Pneumatic input connection	G 3/8
Mode of operation of drive	Double acting
Theoretical cylinder force, advance stroke (at 0.5 MPa)	5,627 N
Theoretical cylinder force, return stroke (at 0.5 MPa)	6,136 N
Maximum piston speed	500 mm/s
Piston rod end	Male thread
Geometric form of the piston rod	Single rod
Male thread of rod end	M30 x 1.5
Female thread of rod end	M22 x 2.5
Minimum piston speed	50 mm/s

## Dimensions

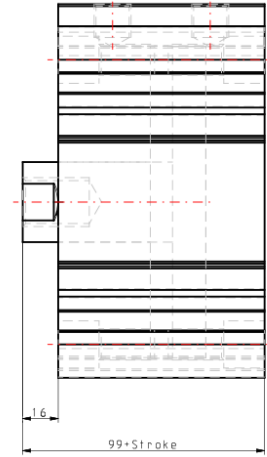
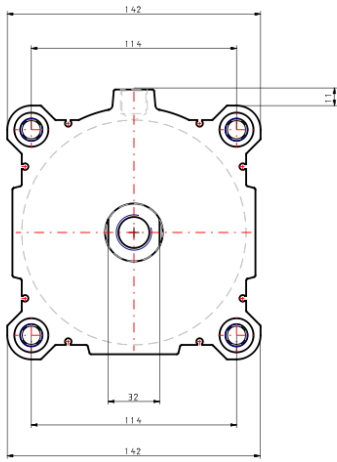



## Constructions

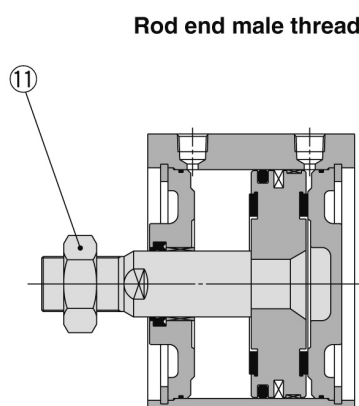
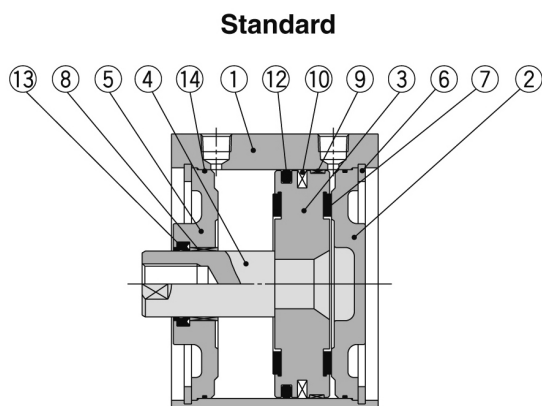

### Component Parts

No.	Description	Material	Note
1	Cylinder tube	Aluminum alloy	Hard anodised
2	Head cover	Carbon steel	Nickel plated
3	Piston	Aluminum alloy	Chromated
4	Piston rod	Carbon steel	Hard chrome plated
5	Rod cover	Carbon steel	Nickel plated
6	Retaining ring	Carbon tool steel	Phosphate coated
7	Bumper	Urethane	
8	Bushing	Bearing alloy	
9	Wear ring	Resin	
10	Magnet	—	For CDQ2B□ only
11	Rod end nut	Carbon steel	Nickel plated
12	Piston seal	NBR	
13	Rod seal	NBR	
14	Tube gasket	NBR	

### Replacement Parts/Seal Kit

Bore size (mm)	Kit no.	Contents
125	CQ2B125-PS	Kits include items ⑫, ⑬, ⑭ from the table.
140	CQ2B140-PS	
160	CQ2B160-PS	
180	CQ2B180-PS	
200	CQ2B200-PS	

\* Seal kit includes ⑫, ⑬, ⑭. Order the seal kit, based on each bore size.  
 \* Since the seal kit does not include a grease pack, order it separately.

**Grease pack part no.:** GR-S-010 (10 g)

## Additional information

Catalogue

[CQ2-Z-B\\_EU.pdf](#)



# HEAVY-DUTY CONVEYOR ROLLER SERIES 3560



Conveyor Rollers  
**Fixed drive**  
Series 3560

Stable fixed drive for small roller pitches

## Product Description

- Customer benefits**
  - Stable, fixed drive conveyor roller
    - Welded steel sprockets, steel tube 60 x 3 mm
  - Conveyor reinforced by captive shaft
    - Female threaded shaft Ø 17 mm
  - Small pitches possible
    - Ø 60 mm and tangential drive
  - Gentle lateral pushing of the materials to be conveyed
    - Rounded tube ends
- Applications**
  - In-house driven conveyance of heavy material to be conveyed for which small roller pitches are required
  - Pallets, steel containers without continuous runners
- Properties**
  - Sealed precision ball bearing (6003 2RZ)
  - Steel sprockets, welded to tube
  - Zinc-plated as a component after welding
- Associated platform**
  - Platform 1700

## Technical Data

### General technical data

Max. load capacity	3,000 N
Max. conveyor speed	1.2 m/s
Temperature range	-5 to +40 °C

### Materials

Bearing housing	Polyamide
Drive head	Steel
Seal	Polyamide
Ball bearing	Steel 6003 2RZ

The load capacity depends on the length of the roller.

### Load capacity

### Female threaded shaft version

Tube material	Ø Tube mm	Ø Shaft mm	Max. load capacity in N with an installation length of mm					
			200	900	1,000	1,100	1,300	1,500
Steel, zinc-plated	60 x 3	17	3,000	3,000	2,910	2,160	1,290	830



# HEAVY-DUTY CONVEYOR ROLLER SERIES 3560



Conveyor Rollers  
**Fixed drive**  
Series 3560

Stable fixed drive for small roller pitches

## Product Selection

### Standards Female threaded shaft version

Material	Ø mm	Torque transmission	Ball bearing	Shaft Reference number Ø 17 mm (M12 x 20)
Steel, zinc-plated	60 x 3.0	Steel sprocket 5/8", Z = 13	6003 2RZ	3.56W.JDC.RAJ
		2 steel sprockets 5/8", Z = 13	6003 2RZ	3.56W.JDB.RAL

**Ordering information** Please state in addition to the reference number the reference length RL and optionally the dimensions for the tube sleeve.

### Ordering example

**Example of a reference number: 3.56A.JDC.RAJ - 464**

This reference number is for a Conveyor Roller Series 3560, Ø tube 60 mm, steel sprocket 5/8", Z = 13, Ø shaft 17 mm, female threaded shaft and reference length 464 mm. The reference length RL can be found on the dimensioned drawing:  $RL = EL - 36$ . The axial play of the sides of 1 mm and 0.5 mm has already been taken into account. The nominal clearance of your conveyor is 500 mm, which also corresponds to the installation length EL, i. e. the reference length is:  $500 - 36 = 464$  mm.

Dimensions	RL	Reference length/Ordering length*
	EL	Installation length
	AGL	Total length of shaft
	F	Length of the bearing assembly, including axial play

\*The reference length/ordering length RL does not have any reference edges on the conveyor roller and can therefore not be shown.

### Dimensions for steel sprocket

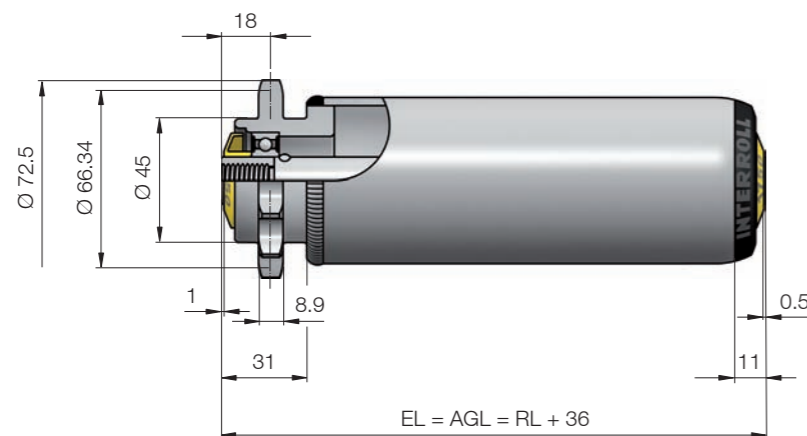

### Dimensions for 2 steel sprockets

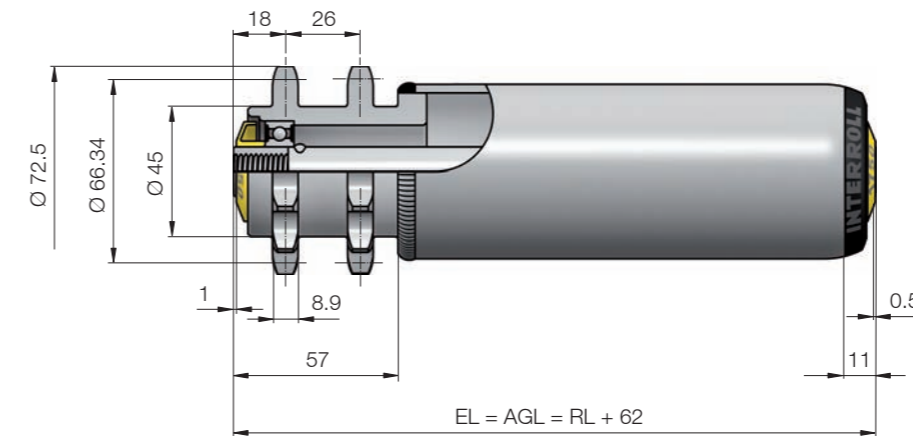

## Options

We can offer you the following options in addition to our standard products:

- Flanges
- Tube sleeves
  - Flexible PVC sleeve
  - Rubber coating



# HEAVY-DUTY CONVEYOR ROLLER SERIES 3600



Conveyor Rollers  
**Fixed drive**  
Series 3600

Sturdy, reliable, cost-effective standard solution

## Product Description

- Customer benefits**
  - Exceptionally low-noise operation
    - Drive heads made of fibreglass-reinforced, viscoplastic polyamide
  - Drive elements secured against twisting and axial movement against the tube
    - Form-fit join with notches at the tube ends
  - Comprehensive drive versions
    - Roller-to-roller and tangential chain drive, toothed belt drive
  - Gentle lateral pushing of the materials to be conveyed
    - Rounded tube ends
- Applications**
  - In-house driven conveyance of heavy materials to be conveyed
  - Pallets, steel containers etc.
- Properties**
  - Sealed precision ball bearing (6204 2RZ, 6205 2RZ)
- Associated platform**
  - Platform 1450

## Technical Data

General technical data	
Max. load capacity	3,500 N
Max. conveyor speed	0.50 m/s
Temperature range	0 to +40 °C
Materials	
Bearing housing	Polyamide
Drive head	Polyamide
Seal	Polyamide
Ball bearing	Steel 6204 2RZ, 6205 2RZ

**Load capacity** The dynamic load and the surface load are the assumptions for the load capacity.

### Female threaded shaft version

Ø Tube mm	Torque transmission	Max. load capacity in N with an installation length of mm							
		200	400	600	800	1,000	1,200	1,400	1,600
80 x 3	Polymer sprocket	3,500	3,500	3,500	3,500	3,500	3,500	3,500	3,500
89 x 3									
80 x 3	2 polymer sprockets or toothed belt head	3,500	3,500	3,150	3,000	2,930	2,880	2,850	2,820
89 x 3									

## Product Selection

### Female threaded shaft version

Tube			Ball bearing	Shaft	
Material	Ø mm	Torque transmission		Reference number	
				Ø 20 mm (M12 x 20) without flange	Ø 20 mm (M12 x 20) with flange
Steel, zinc-plated	80 x 3.0	Toothed belt head	6205 2RZ	3.6AZ.J8E.S38	3.6AZ.J8D.S38
			6204 2RZ		
		Polymer sprocket 5/8", Z = 18	6205 2RZ	3.6AJ.J8E.S42	3.6AJ.J8D.S42
			6204 2RZ		
		Polymer sprocket 5/8", Z = 15	6205 2RZ	3.6AC.J8E.S42	3.6AC.J8D.S42
			6204 2RZ		
	89 x 3.0	2 Polymer sprockets 5/8", Z = 18	6205 2RZ	3.6AK.J8E.S38	3.6AK.J8D.S38
			6204 2RZ		
		2 polymer sprockets 5/8", Z = 15	6205 2RZ	3.6AD.J8E.S38	3.6AD.J8D.S38
			6204 2RZ		
		Toothed belt head	6205 2RZ	3.6AX.J90.S38	3.6AX.J8C.S38
			6204 2RZ		
Polymer sprocket 5/8", Z = 18	6205 2RZ	3.6AL.J90.S42	3.6AL.J8C.S42		
	6204 2RZ				
Polymer sprocket 5/8", Z = 15	6205 2RZ	3.6AE.J90.S42	3.6AE.J8C.S42		
	6204 2RZ				
2 polymer sprockets 5/8", Z = 18	6205 2RZ	3.6AM.J90.S38	3.6AM.J8C.S38		
	6204 2RZ				
2 polymer sprockets 5/8", Z = 15	6205 2RZ	3.6AF.J90.S38	3.6AF.J8C.S38		
	6204 2RZ				

## Standards

On request, we can offer you further options in addition to our standard products (cf. the following double page).

### Example for a reference number: 3.6AC.J8E.S42 - 464

This reference number is for a Conveyor Roller Series 3600, steel, zinc-plated, Ø tube 80 mm, polymer sprocket 5/8", Z = 15, Ø shaft 20 mm, female threaded shaft without flange and reference length 464 mm. The reference length RL can be found on the dimensioned drawing:  $RL = EL - 36$ . The axial play of 0.5 mm per side has already been taken into account. The nominal clearance of your conveyor is 500 mm, which also corresponds to the installation length EL, i. e. the reference length is:  $500 - 36 = 464$  mm.

## Order example



# HEAVY-DUTY CONVEYOR ROLLER SERIES 3600



Conveyor Rollers  
**Fixed drive**  
Series 3600

Sturdy, reliable, cost-effective standard solution

**Dimensions**

RL	Reference length/Ordering length*
EL	Installation length
AGL	Total length of shaft

### Dimensions for polymer sprocket 5/8", without flange

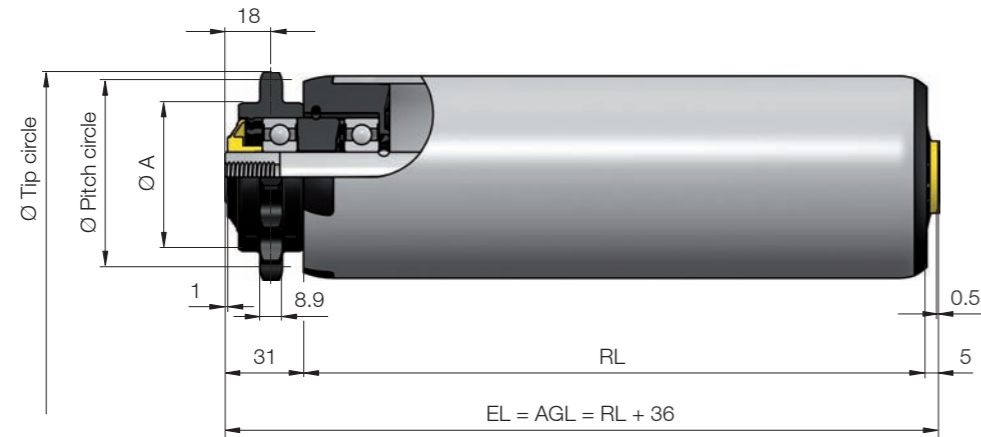

Number of teeth	Ø Tip circle mm	Ø Pitch circle mm	Ø A mm
15	83	76.36	59
18	98	91.42	66

### Dimensions for 2 polymer sprockets 5/8", without flange

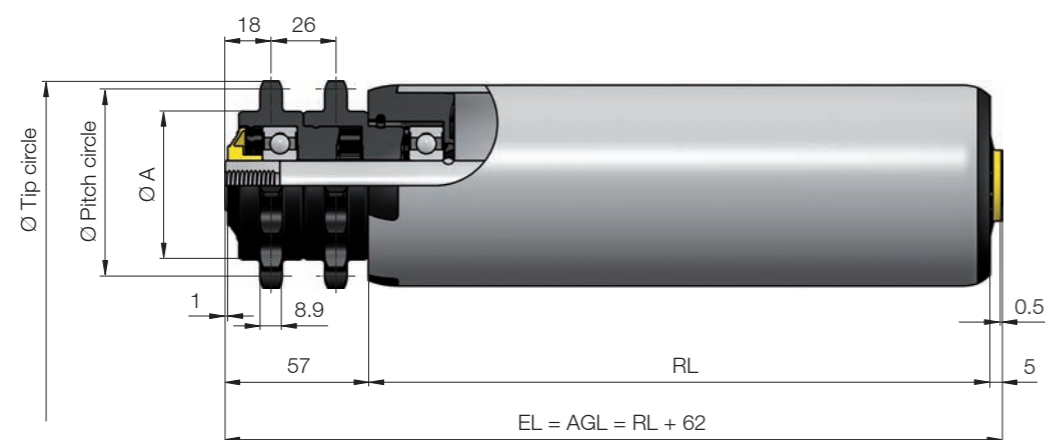

Number of teeth	Ø Tip circle mm	Ø Pitch circle mm	Ø A mm
15	83	76.36	59
18	98	91.42	66

### Dimensions for toothed belt head without flange

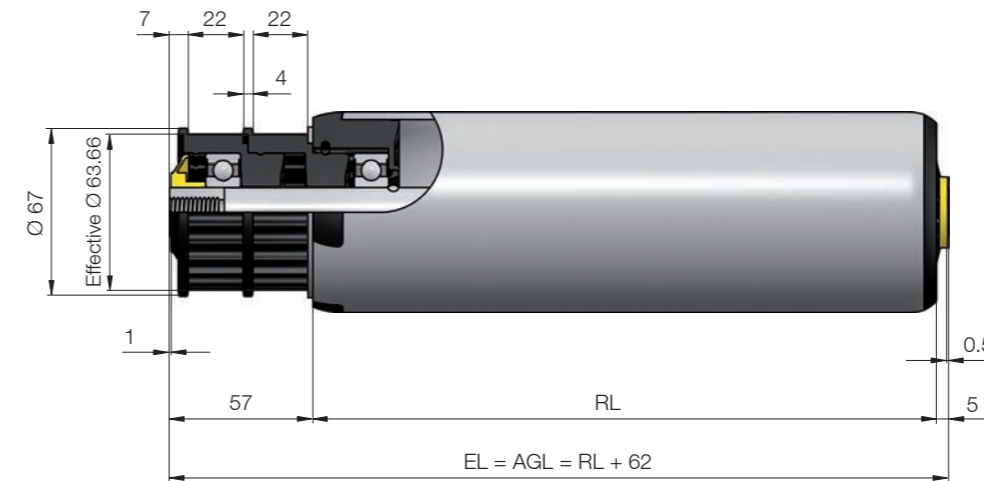

### Dimensions for flange

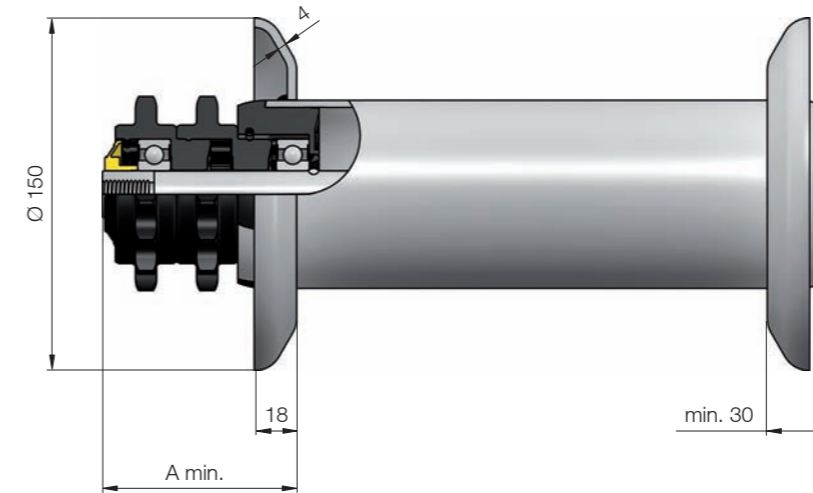

Drive	Pitch A of flange mm
Sprocket	Min. 56
2 sprockets	Min. 82
Toothed belt	Min. 82

### Options

We can offer you the following options in addition to our standard products:

- Steel tube, zinc-plated Ø 80 x 2 mm

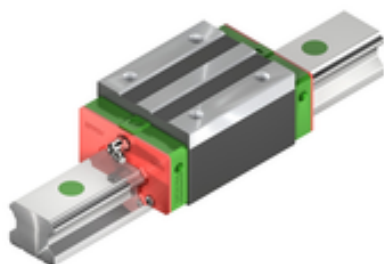

Dimensional drawing

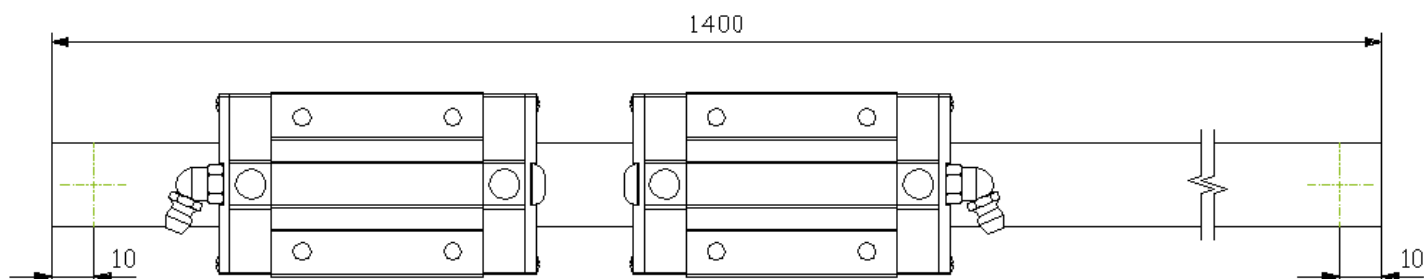

Configuration attributes:

**HGH20CA2T1400Z0H+CZS**

Series	HG	
Block type	H	high square block
Size	20	
Load type	C	heavy load
Block mounting	A	from above
Blocks per rail	2	
Rail mounting	T	From below
Rail length	1400	
Block preload	Z0	light preload
Precision code	H	
Rails per axis	1	
Sealing system	SS	
Self lube type	N	Without oil lubrication unit
Coating	HICOAT_ CZS	HICOAT CZS



Load rates and moments

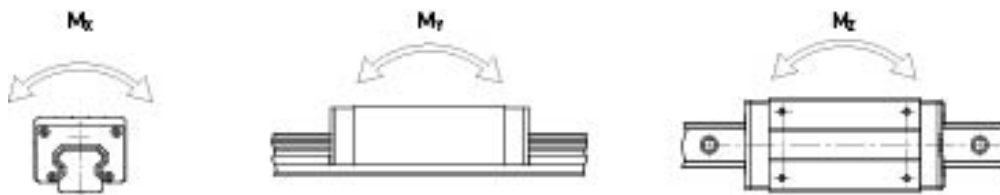

Series/ Size	Dynamic load rate $C_{dyn}$ [N] <sup>1)</sup>	Static load rate $C_0$ [N]	Dynamic moment [Nm]			Static moment [Nm]		
			$M_x$	$M_y$	$M_z$	$M_{0x}$	$M_{0y}$	$M_{0z}$
HG_20C	17750	27760	178	126	126	270	200	200

<sup>1)</sup> Dynamic load rate for 50,000 m travel distance

Block measurements [mm]

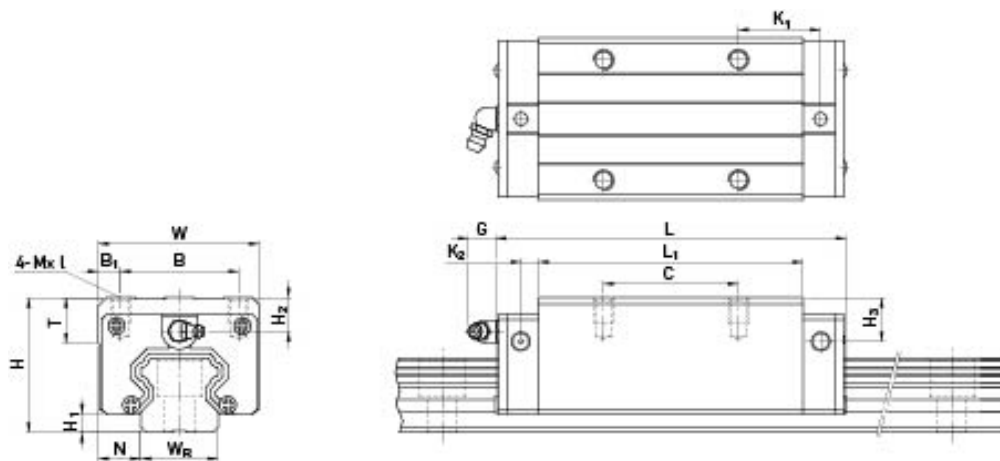

Series/ Size	Mounting dimensions [mm]			Load rates [N]		Weight [kg] m
	H	$H_1$	N	$C_{dyn}$	$C_0$	
HGH20CA	30	4.6	12	17750	27760	0.3

Series/ Size	Block measurements [mm]																		
	W	B	$B_1$	C	$C_1$	$L_1$	L	$K_1$	$K_2$	M	G	$G_n$	T	$T_1$	$T_2$	$H_2$	$H_3$	$L_k$	$L_{k1}$
HGH20CA	44	32	6	36	-	50.5	77.5	12.25	6	M5	12	-	8	-	-	6	6	-	-

Rail measurements [mm]

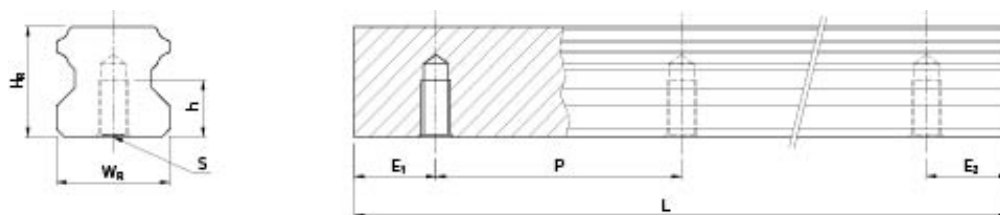

Series/ Size	Assembly screw for rail	Rail measurements [mm]								
		$W_R$	$W_B$	$H_R$	D	H	d	P	$L_K$	$L_{K1}$
HGR20T	-	20	-	17.5	-	10		60	-	-

Specifications for your order:

HGH20CA2T1400Z0H+CZS

Profilschienenführung

Laufwagen und Profilschienen beschichtet mit HICOAT CZS

erstbefettet (HIWIN G03)

- Teilstück 1 (1x): 1400 mm (10 / 23x60 / 10)

HGH20CAZ0H+CZS (2 Stück)

Schmiernippel 67.5°

**Note:**

You can find information on lubrication and assembly in our assembly instructions

<https://www.hiwin.de/hiwin/de/EUR/service/downloads>