



**Universidad de Valladolid**



**ESCUELA DE INGENIERÍAS  
INDUSTRIALES**

**UNIVERSIDAD DE VALLADOLID  
ESCUELA DE INGENIERIAS INDUSTRIALES**

**Grado en Ingeniería Mecánica**

**Design of Quadcopter**

**Autor:**

**Crego Ruiz, Raúl**

**Responsable de Intercambio en la Uva:**

**Marta Herráez Sánchez**

**Universidad de destino:**

**VILNIUS TECH**

**Valladolid, Julio de 2022.**

## TFG REALIZADO EN PROGRAMA DE INTERCAMBIO

---

TÍTULO: Design of Quadcopter  
ALUMNO: Raúl Crego Ruiz  
FECHA: 01/06/2022  
CENTRO: Mechanics Faculty  
UNIVERSIDAD: Vilnius Tech  
TUTOR: Ina Tetsman

## RESUMEN

---

Se diseñará la geometría de un dron que sea capaz de cargar con dos kilogramos extra de peso a partir de la elección de sus hélices, motores, batería y demás componentes electrónicos necesarios. El objetivo principal del mismo es enviar un kit de primeros auxilios a alguien que esté en una situación de difícil acceso, como un montañero, hasta que se le pueda rescatar, aunque puede ser utilizado con cualquier otro propósito para el que se ajusten sus prestaciones.

## KEYWORDS

---

Quadcopter, dron, radio-control, delivery, rescate



VILNIUS GEDIMINAS TECHNICAL UNIVERSITY  
FACULTY OF MECHANICS  
DEPARTMENT OF MECHANICAL AND MATERIALS ENGINEERING

Raul Crego Ruiz

**DESIGN OF QUADCOPTER**  
**KVADROKOPTERIO PROJEKTAVIMAS**

Bachelor's degree final work (project)

Mechanical Engineering study programme, state code 6121EX040

Machine Design specialisation

Mechanical Engineering study field

Vilnius, 2022

VILNIUS GEDIMINAS TECHNICAL UNIVERSITY  
FACULTY OF MECHANICS  
DEPARTMENT OF MECHANICAL AND MATERIALS ENGINEERING

APPROVED BY  
Head of Department

\_\_\_\_\_  
(Signature)  
Assoc Prof Dr I. Tetsman  
(Name, Surname)

\_\_\_\_\_  
(Date)

Raul Crego Ruiz

**DESIGN OF QUADCOPTER**  
**KVADROKOPTERIO PROJEKTAVIMAS**

Bachelor's degree final work (project)

Mechanical Engineering study programme, state code 6121EX040

Machine Design specialisation

Mechanical Engineering study field

**Supervisor:** Assoc Prof Dr Ina Tetsman \_\_\_\_\_  
(Title, Name, Surname) (Signature) (Date)

Vilnius, 2022

VILNIAUS GEDIMINAS TECHNICAL UNIVERSITY  
FACULTY OF MECHANICS  
DEPARTMENT OF MECHANICAL AND MATERIALS ENGINEERING

Mechanical Engineering study field  
Mechanical Engineering study programme, state code 6121EX040  
Machine Design specialisation

APPROVED BY  
Head of department

\_\_\_\_\_  
(Signature)

\_\_\_\_\_  
(Name, Surname)

\_\_\_\_\_  
(Data)

**OBJECTIVES FOR BACHELOR'S DEGREE FINAL WORK (PROJECT)**

.....No. ....  
Vilnius

For student: ..... Raul Crego Ruiz.....  
(Name, Surname)

Final work (project) title: .....Design of Quadcopter.....  
..... Kvarokopterio projektavimas.....

Approved on .....by Dean's degree No. ....

The Final work has to be completed by 2022 m. June 1 d.

**THE OBJECTIVES:**

Data: dimensions of body: do not exceed 2000 mm x 2000 mm x 800 mm; weight does not exceed 10 kg;  
Must be autonomous in case loss of signal....

Explanatory note: Introduction; Analysis of similar devices; Arguments of selected decisions; Calculations of construction parameters and internal stress; Determination of the requirements safety work using device. Environmental requirements. Economical calculations. Conclusions. List of references

Drawings: Drawing of Quadcopters general view (1page - A1); Drawing of Quadcopter's motor assembly (1page - A1); Part drawing (0,5 page – A1); Economical indicators (0.5 page - A1); Analysis of similar devices (1 page - A1);

Consultants of the final degree work (project).....  
(Title, Name, Surname)

Academic Supervisor.....  
(Signature)

.....Assoc. prof. Dr. Ina Tetsman.....  
(Title, Name, Surname)

Objectives accepted as a guidance for my Final work (project)

.....  
(Signature)

..... Raul Crego Ruiz.....  
(Student's Name, Surname)

.....2022 03 28.....  
(Date)

## ANNOTATION

Vilnius Gediminas Technical University  
Mechanics faculty  
Mechanical and material engineering department

ISBN        ISSN  
Copies No. ....  
Date ....-....-....

Mechanical Engineering study programme bachelor (master) thesis.

Title: Design of quadcopter

Author Raúl Crego Ruiz

Academic supervisor Dr. Ina Tetsman

**Thesis language**

Lithuanian

Foreign (English)

### **Annotation**

In the final bachelor's work was designed a drone that can carry 2 kilograms.

After examining possible designs of drones, selected X frame shape drone. Estimating its weight, choosing the components according to it and designing the frame to distribute them is necessary for design. After designing, final parameters are calculated such as endurance or maximum yaw and roll and it is described the assembly step by step. Using Catia V5 static software strength parameters are simulated.

The paper consists of introduction, analysis of constructions, drone basic parameters calculations, strength calculations, assembly explaining, economic calculations, requirements for work and environmental safety, economic calculations, and conclusions.

Explanatory part – 61 pages. Without appendixes, 33 illustrations, 20 tables, 18 bibliography sources, graphics part – 3 pages A1 format, one page A2 format, one page A3 format and 2 pages A4 format.

### **Keywords:**

Quadcopter, drone, radio-control, delivery.

# CONTENT

LIST OF PICTURES .....	7
LIST OF TABLES .....	8
Introduction.....	9
1. Analysis of similar designs and argument of the decision.....	10
1.1. Technology of a quadcopter.....	10
1.2. Advantages and disadvantages of some models .....	13
1.3. Argument of the decision .....	19
2. Construction parameter calculations.....	20
2.1. Estimation of weight and estimated thrust and endurance.....	20
2.2 Choices of the electronic components.....	24
2.3. Design of the frame and dynamic calculations .....	40
2.4. Technological process.....	47
2.5. Internal stress test.....	49
3. SAFE WORK AND ENVIRONMENTAL PROTECTION REQUIREMENTS .....	51
3.1. Regulations, safety and security.....	51
3.2. Environmental impact .....	53
4. ECONOMIC CALCULATION.....	54
4.1. Project cost calculation .....	54
4.2. Break even point calculation and payback period.....	58
CONCLUSIONS .....	60
REFERENCES .....	61
ANNEXES.....	62
Annexe 1. Part list General View.....	62
Annexe 2. Part list Assembly Drawing .....	64



## LIST OF PICTURES

Fig. 1.1. Exploded view of WO 2014067224 A1. ....	10
Fig. 1.2. Exploded view of WO 2014067224 A1 upside down. ....	11
Fig. 1.3. 3D view of USD864082S. ....	13
Fig. 1.4. 3D drawing of USD864082S. ....	15
Fig. 1.5. 3D drawing of USD747775S with propellers non lined up. ....	16
Fig. 1.6. 3D drawing of USD747775S with propellers lined up. ....	17
Fig. 1.7. 3D drawing of USD829283S. ....	18
Fig. 2.1. Parameters of the drone calculated from the estimations. ....	21
Fig. 2.2. Graphics of the performance of the drone from the estimations. ....	21
Fig. 2.3. Parameters of the drone calculated from better estimations. ....	22
Fig. 2.4. Graphics of the performance of the drone from better estimations. ....	23
Fig. 2.5. Propeller Mejzlik 26 inches. ....	24
Fig. 2.6. Annotation of measures of the motor selected. ....	26
Fig. 2.7. Motor selected ....	26
Fig. 2.8. Motor selected reverse view ....	27
Fig. 2.9. Selected motor fixing elements ....	27
Fig. 2.10. Battery selected. ....	28
Fig. 2.11. ESC selected. ....	31
Fig. 2.12. Autopilot selected. ....	33
Fig. 2.13. GPS selected. ....	34
Fig. 2.14. Power module selected ....	35
Fig. 2.15. Receiver selected ....	37
Fig. 2.16. Transmitter selected. ....	38
Fig. 2.17. Camera selected. ....	39
Fig. 2.18. 3D view of the drone. ....	40
Fig. 2.19. Fixing part ....	41
Fig. 2.20. Parameters output by Mejzlik calculator ....	43
Fig. 2.21. Electronic components distribution. ....	44
Fig. 2.22. External forces at the drone ....	46
Fig. 2.23. Internal stress test, scale 1 ....	49
Fig. 2.24. Internal stress test, scale 2. ....	50
Fig. 4.1. Costs per unit. ....	57
Fig. 4.2. Payback period ....	59

## LIST OF TABLES

Table 2.1. Estimated weight of the components.....	21
Table 2.2. Propeller specifications.....	25
Table 2.3 Motor specifications .....	26
Table 2.4 Battery specifications.....	29
Table 2.5 ESC specifications .....	31
Table 2.6 Autopilot specifications .....	33
Table 2.7 GPS specifications .....	34
Table 2.8 Power module specifications .....	36
Table 2.9 Receiver specifications .....	37
Table 2.10 Camera specifications .....	39
Table 2.11 Weight of the components .....	42
Table 2.12 Steps to assembly the drone.....	48
Table 4.1 Catalogue parts costs .....	54
Table 4.2 Stock materials costs.....	54
Table 4.3 Standard part costs .....	55
Table 4.4 Total supply costs .....	55
Table 4.5 Equipment costs.....	55
Table 4.6 Manufacturing costs.....	56
Table 4.7 Operation costs .....	56
Table 4.8 Fixed and variable costs.....	58

## **Introduction**

The quadcopters that are done for carrying weight are not very usual yet.

The object of this project is modelling a drone that is capable to carry two kilograms.

The purpose of this drone is to deliver a first aid kit to a person that is trapped in a difficult access place, like in the mountains, to survive until the rescue team arrives, but it can be used for other purposes that need delivering until two kilograms.

In this thesis some drones will be reviewed to see what design of frame is more suitable for our purpose, analysing the advantages and disadvantages of them.

Then, necessary elements for system design will be chosen according to the parameters provided.

After that, the frame will be designed to hold all the components that were chosen, after doing some estimations of the future parameters

It will be also calculated the definitive parameters, talked about manufacturing and assembling and will be done an internal stress test to check that it will not brake.

Finally, the economic calculators will be calculated, and its environmental requirements will be commented

To sum up, conclusions will be presented.

# 1. Analysis of similar designs and argument of the decision

## 1.1. Technology of a quadcopter

To understand how works a quadcopter, the model WO 2014067224 A1 can serve as a general example. Every annotation of this point is referred to the following figures (Fig. 1.1 and Fig. 1.2).

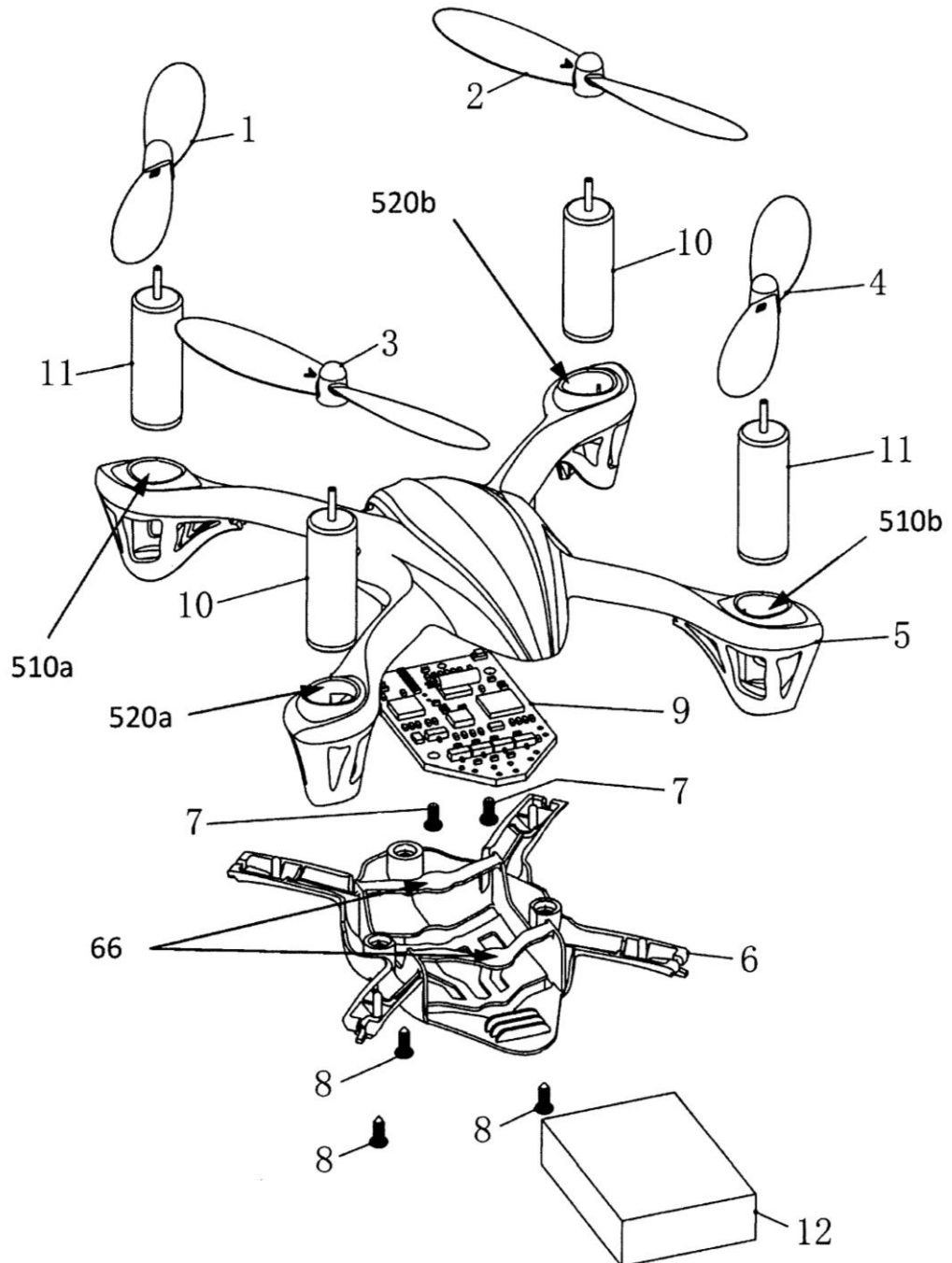

**Fig. 1.1.** Exploded view of WO 2014067224 A1. [1]

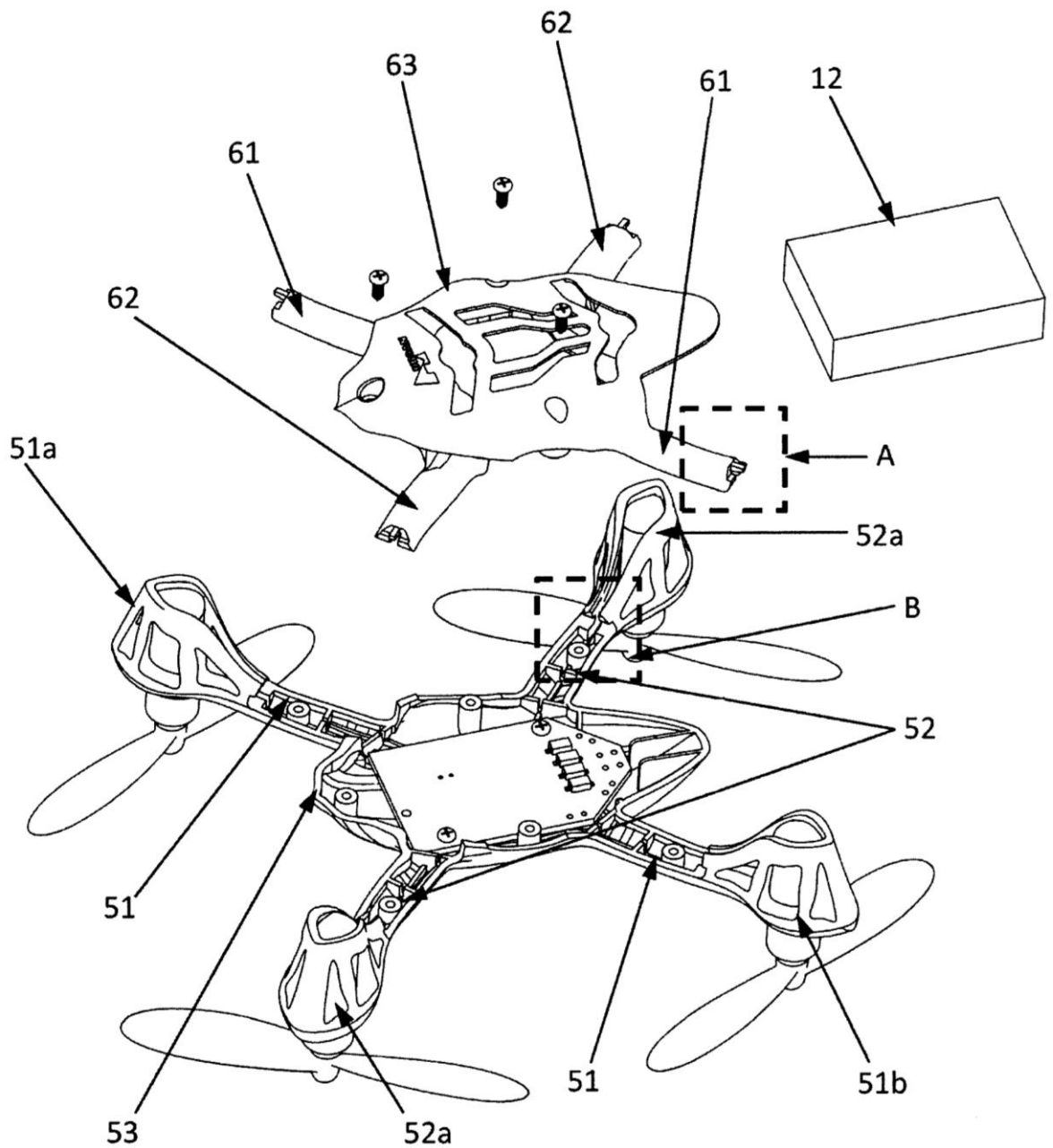

**Fig. 1.2.** Exploded view of WO 2014067224 A1 upside down. [1]

Basically, a quadcopter is a mechanical vehicle with four arms, and at the end of each arm there is a motor attached to its propeller. They do not move and hover because of their aerodynamical properties, like the wings of airplanes, only because of the spin of their propellers, and they need a computer to convert the inputs commands in the correct outputs, changing the speed spin of each propeller, to reach the desired motion. The four movements of a quadcopter are throttle, yaw, pitch and roll.

The four forces that act on a quadcopter are:

- Gravity: The weight.

- Lift: The upward reaction force due to the spin of the propellers.
- Thrust: The horizontal reaction force due to the spin of the propellers.
- Drag: This is a backward force on the drone due to the friction with air.

A four-rotor aircraft usually comprises a hood (5, 6), which protects the battery (12) and the PCB board (9). The four arms (51, 52, 61, 62) are fixed to the hood, and at the other end of each arm we can find each propeller (1, 2, 3, 4).

The hood and arms are normally comprised by two pieces, upper part and lower part, as we can see. In this case, the upper hood is the main one, that has the upper half part of the hood (5), almost the entire arms (51, 52), with each end portion (51a, 51b, 52a, 52b) and de whole propeller supports (510a, 510b, 520a, 520b). The PCB board is connected to this part. The lower shell works as a support for the battery (12) and protects it, the PCB board and includes a battery holder (66). It is the place where the landing gear is fixed.

Each propeller (1, 2, 3, 4) is directly connected to its electric motor (11, 12), held in their holes (510a, 510b, 520a, 520b).

It is important that if two of the first motor (11) are configured to rotate clockwise, the two second electric motors (10) are arranged to rotate counterclockwise, and vice versa. This is to compensate the pairs of reaction pairs with each other. [1]

There are more details in this quadcopter model that I will not develop because they are particularities and not general guidelines, such as the way to remove or replace the battery, the battery charging port, the camera, the propeller protections (which are removable in this example), LED lights to see the position of the drone at night, battery indicators, headlights, etc.

Notice that I am going to analyse the advantages and disadvantages of this model in next sub-chapter, although I have described it as a general example.

## 1.2. Advantages and disadvantages of some models

In this subchapter I am going to analyse some advantages and disadvantages of different models of quadcopters, in order to design my quadcopter with the best qualities for its proposal.

### 1.2.1. USD864082S

We can see a 3D drawing of this model (Fig. 1.3.). I have chosen it because it has many aspects that I consider very suitable and others that I think that can be improvable.

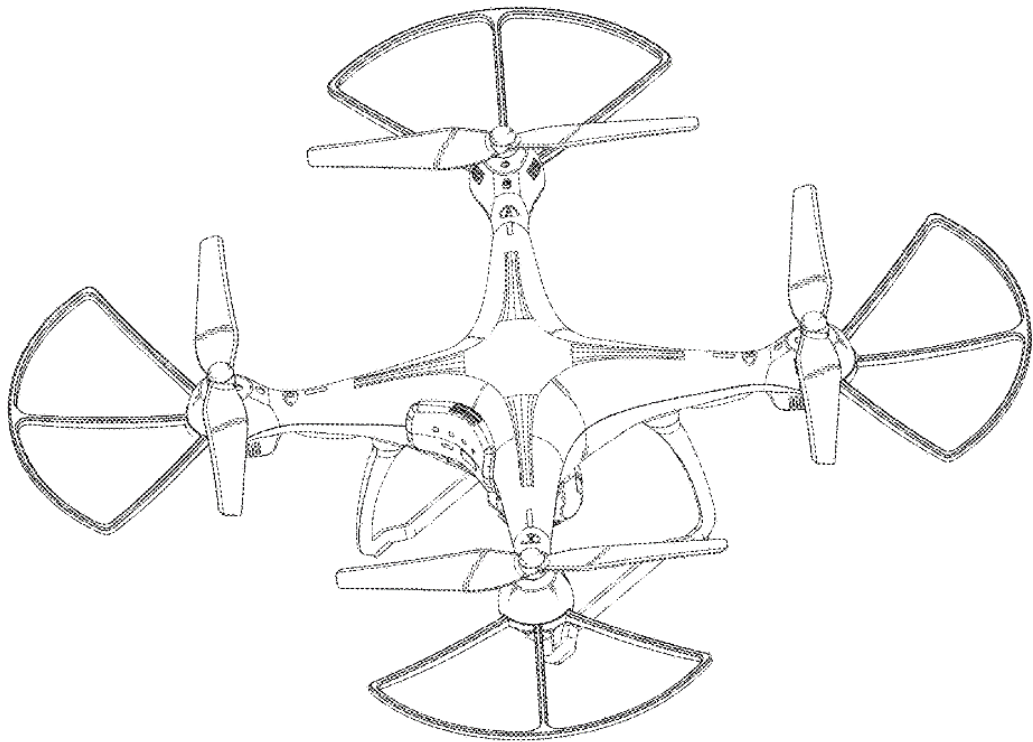

**Fig. 1.3.** 3D view of USD864082S. [2]

Advantages:

- Camera for monitoring quadcopter's situation.
- Strong landing gear based on two strong supports.
- Propeller protection for accidents or collisions.
- Totally symmetric design, more manoeuvrable.

Disadvantages:

- Propeller protection is not whole, it could crash with cables, corners, traffic signs...

- Curved design of fuselage, arms and landing gear, which is more difficult and expensive to design and make.
- Totally symmetric design (does not have a defined front and bottom side), that apparently could be worse to the aerodynamic.



### 1.2.2. WO2014067224A1

Although this is the model that I chose at subchapter 1.1 to explain how a quadcopter works, it has also some advantages and disadvantages to analyse. We can see a general 3D drawing (Fig. 1.4.).

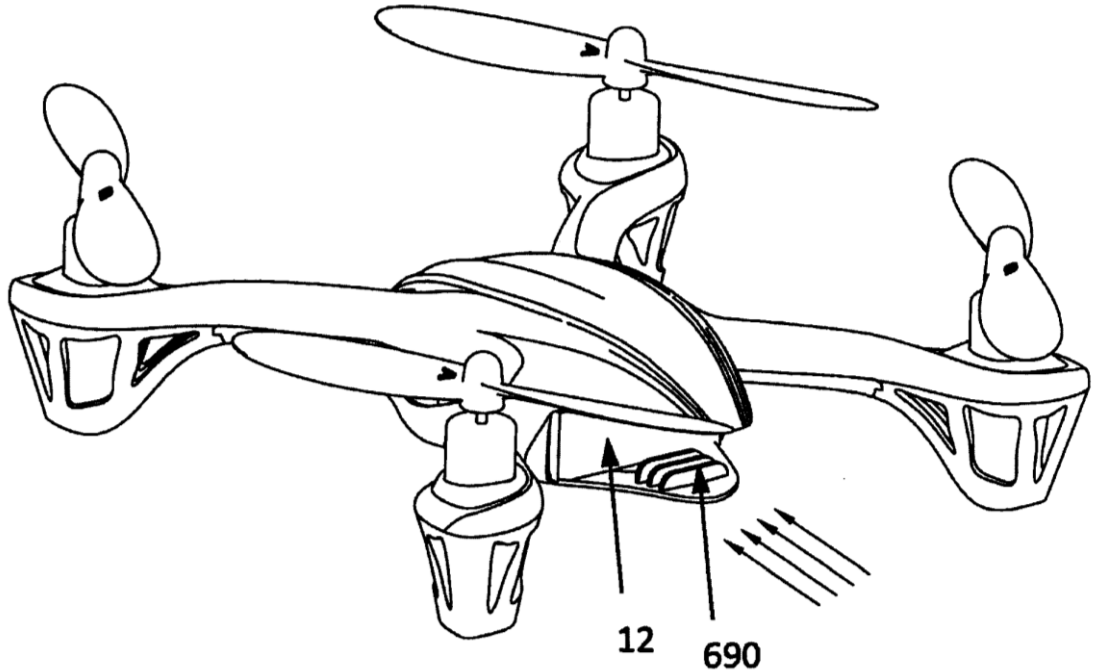

**Fig. 1.4.** 3D drawing of USD864082S. [1]

#### Advantages:

- Removable whole protection for propellers. Can be removed to be lighter and reach more autonomy and speed or stay assembled to get more protected.
- Has landing gear.
- Has defined a front and bottom side, like a VTOL, so it is better for aerodynamic, speed and autonomy

#### Disadvantages:

- Whole protection is heavy, it will decrease autonomy and speed.
- Curved design of fuselage, which is more difficult and expensive to design and make.
- Front and bottom side defined, so the quadcopter will be less manoeuvrable.
- Landing gear based on four short legs under de propeller, so landing area needs to be smoother, and landing needs to be more delicate.

### 1.2.3. USD747775S

This model is so particular because its propellers have the special property that they can move two by two to line up and increase power while going up (Fig. 1.5. and Fig. 1.6.).

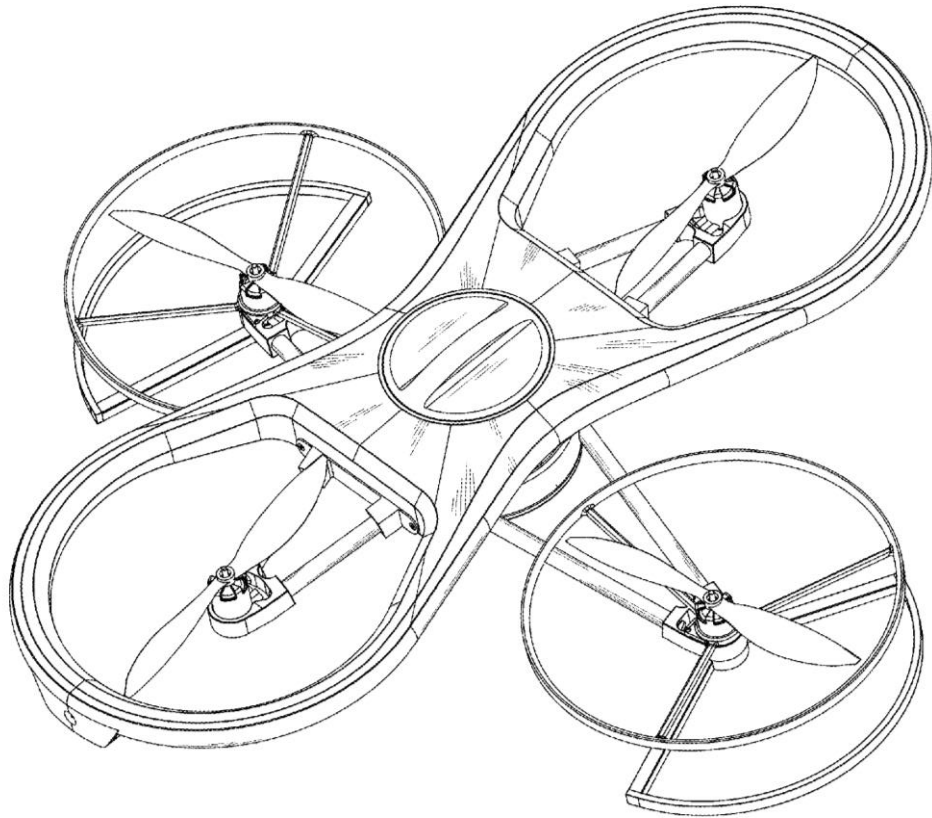

**Fig. 1.5.** 3D drawing of USD747775S with propellers non lined up. [3]

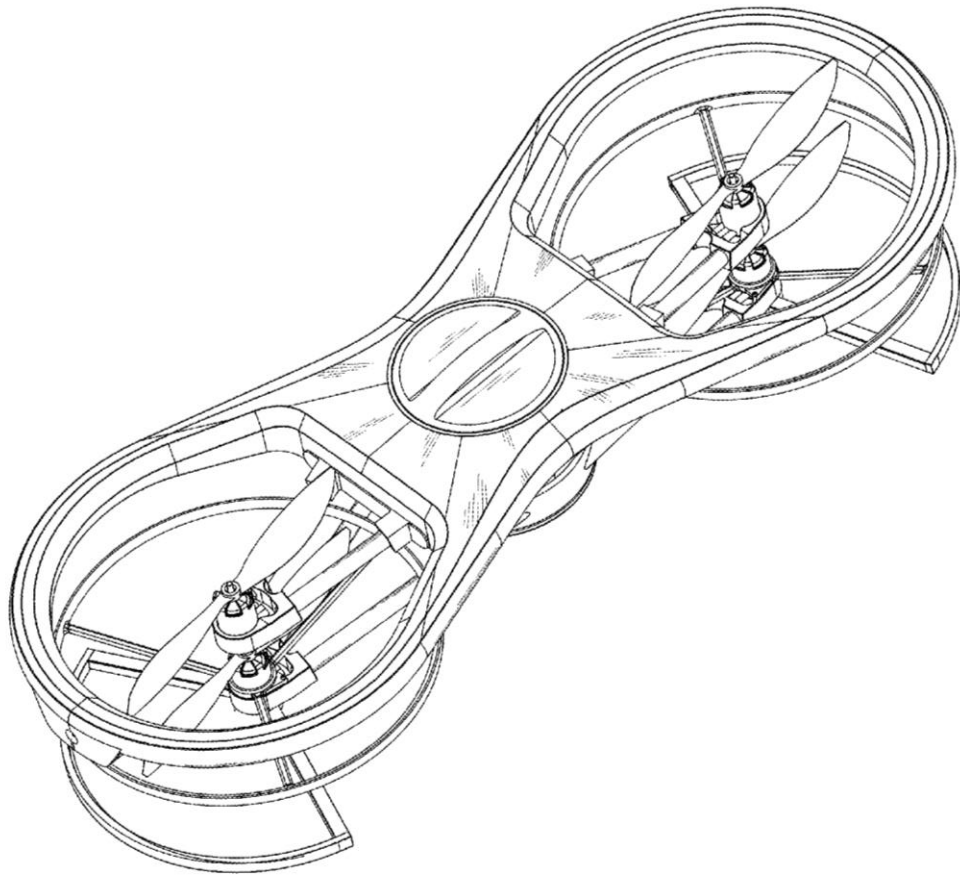

**Fig. 1.6.** 3D drawing of USD747775S with propellers lined up. [3]

#### Advantages

- Propellers strongly protected.
- Propellers in different plains 2 by 2 for putting series propellers to reach more speed and power when ascending.
- Protections guide the air flow from one propeller to the following when they are series.
- Non defined front and bottom, more manoeuvrable.

#### Disadvantages

- More complicated mechanisms and designs, what will increase costs.
- Heavy protection will decrease speed and autonomy.
- Non defined front and bottom, less aerodynamic.
- Does not have landing gear.

### 1.2.4. USD829283S

This model has a quite different geometry, so it is interesting to study it (Fig. 1.7.).

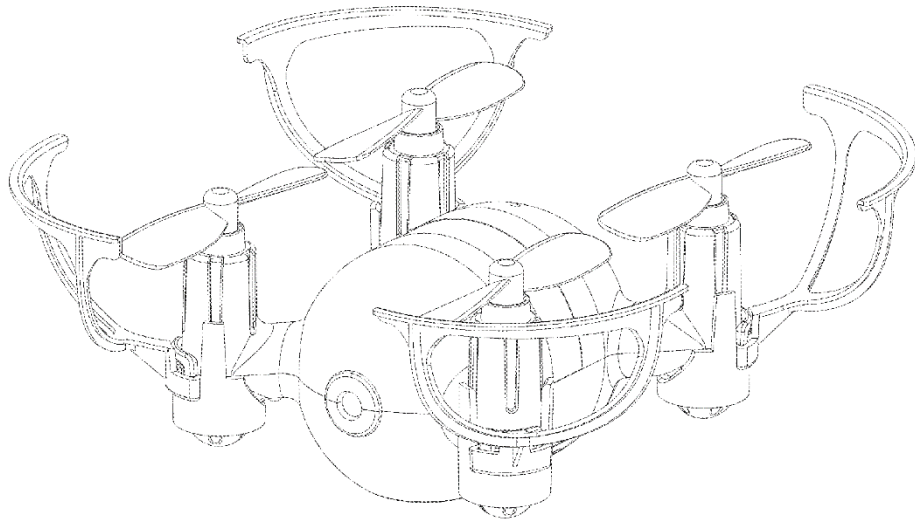

**Fig. 1.7.** 3D drawing of USD829283S. [4]

#### Advantages

- Different type of protection, partial but better than the partial ones seemed before, protects also vertical moves.

- Simple design (no complicated shapes of fuselage, arms and protections).

#### Disadvantages

- Propellers very close, could be less stable, easier to overturn.

- Very big fuselage, less stable.

- No landing gears.

- Apparently higher aerodynamic drag than the others.

### **1.3. Argument of the decision**

After analysing the advantages and disadvantages of the previous models, I have decided to do a quadcopter with front and bottom side defined, to increase top speed minimizing drag force.

The delivery box will integrate the landing gear and will be prepared for carrying a maximum of two kilograms, but this part is not concerned in the thesis, only the drone. The content inside the box must be thought with the design of the box, because it must not move inside and must have the centre of mass situated in the central point. An expert may decide what are the most important things to get in, maybe such as water, food, a blanket or a first-aid kit, and they will be well distributed.

The landing gear will be made up of four short legs under the delivery pack, because this delivery pack protects the frame and absorbs the hit of landing, so it does not need a more sophisticated one.

The propellers will not have protections at first, because this drone is thought to be flid by a qualified professional. Some gear with this proposal can be added then to improve the design, if the autonomy of the drone is enough to assume this extra weight.

The maximum delivery load that it will carry will be about 2 kilograms, what is enough to deliver some basic things to a person who is trapped in some place of difficult access like mountains.

It may have a camera, for monitoring where is the drone going. It is very important because it is probably that the drone will be flid without direct eye contact, so the camera is essential to fly the drone without crashing it

It will not have any mechanism to put the propellers coaxial two by two like USD747775S because it would increase a lot the developing and manufacturing costs, and it is unnecessary to a vehicle with a purpose with a level of risk like delivering.

## 2. Construction parameter calculations

### 2.1. Estimation of weight and estimated thrust and endurance

First, the total weight will be estimated to start calculating how much thrust does the drone need and sizing the propellers, motors and battery. The first estimation was the following, in Table 2.1., with the components and their approximated weights, in grams:

**Table 2.1** Estimated weight of the components.

Element	Weight
Cage for delivery and content	2000g
Battery	1000g
Motors	4x250g
Propellers	4x50g
ESCs	4x15g
Autopilot (with GPS, telemetry, etc.)	50g
Receiver	30g
Camera	12g
Frame	

Without the knowledge of an accurate estimated weight for the frame, it will be set a large one, to be prepared for unexpected increases, so the total weight estimation will be six kilograms. This means that the frame will be more than 1.5 kilograms weight.

The iterations were done using the static thrust calculator provided by Mejzlik [5] to find the most suitable components for my quadcopter. It is a calculator that this propeller brand offers for helping you choosing your propellers. You input your propeller's diameter, the thrust per propeller you need, the number of blades per propeller, the air density and the motor efficiency. Some sizes were tried, and then were researched some motors and batteries that fitted well with my propellers to find a satisfactory combination between maximum thrust and endurance, because inputting the specifications of the motor and battery, it outputs more parameters like maximum thrust, unused power, endurance, current, etc.

Before trying the calculator, the first results were compared with handmade calculations. The results of the calculator were the same as the handmade ones, so for going quicker in the iteration process the calculator was used.

Notice that in the thrust per propeller is unput the total estimated weight (six kilograms) divided into the four propellers, so the thrust per propeller is 1.5 kilograms per propeller.

With the approximations done, the calculator gives the following outputs (Fig. 2.1 and 2.2):

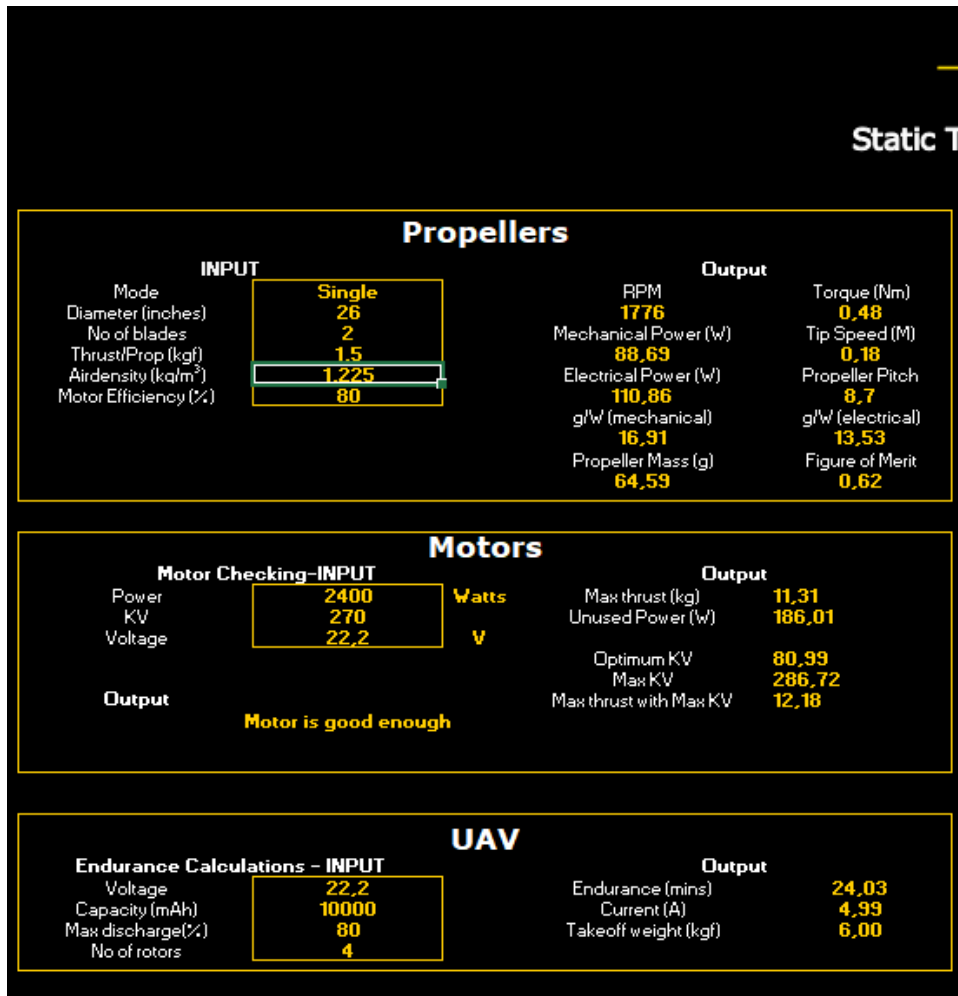

Fig. 2.1. Parameters of the drone calculated from the estimations. [5]

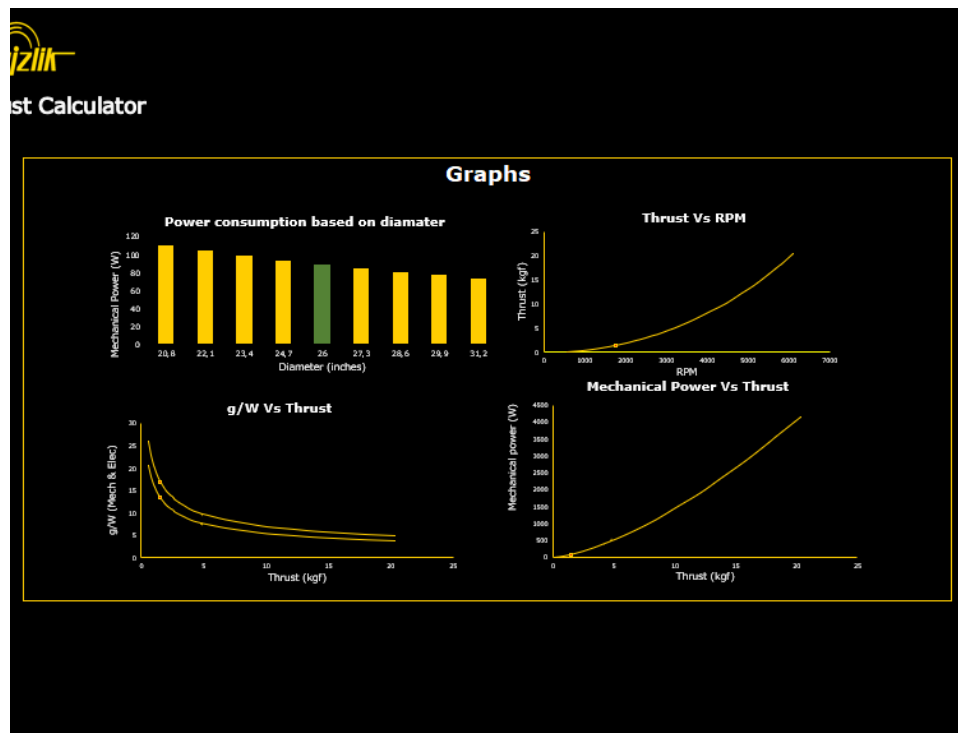

Fig. 2.2. Graphics of the performance of the drone from the estimations. [5]

The endurance that it shows is very optimistic because it is supposed that it is only needed the exact thrust per propeller that the weight requires. It is seen in the graphic g/W vs Thrust. If more thrust is needed, the g/W decrease significantly, what also decreases the endurance too.

To estimate a more realistic thrust per propeller, it is necessary to use a Power-to-Weight ratio. The higher ratio, the easier to control your drone. For example, racing and acrobatic drones require 4:1 Power-to-Weight ratio or higher, but this is not our case, so a lower ratio will be chosen, one enough to a good working of the drone. []

Knowing that the purpose of the quadcopter is to go to a place, as straight as possible, it is going to be chosen the less restrictive one, that is 2:1. This means that the quadcopter will be able to hover at half throttle, so it will have the other half for manoeuvring and moving forward.

It must be multiplied the last thrust per propeller by two to applicate the coefficient, so it is input a three in the thrust per propeller cell. The results with this Power-to-Weight ratio are the followings (Fig. 2.3 and 2.4):

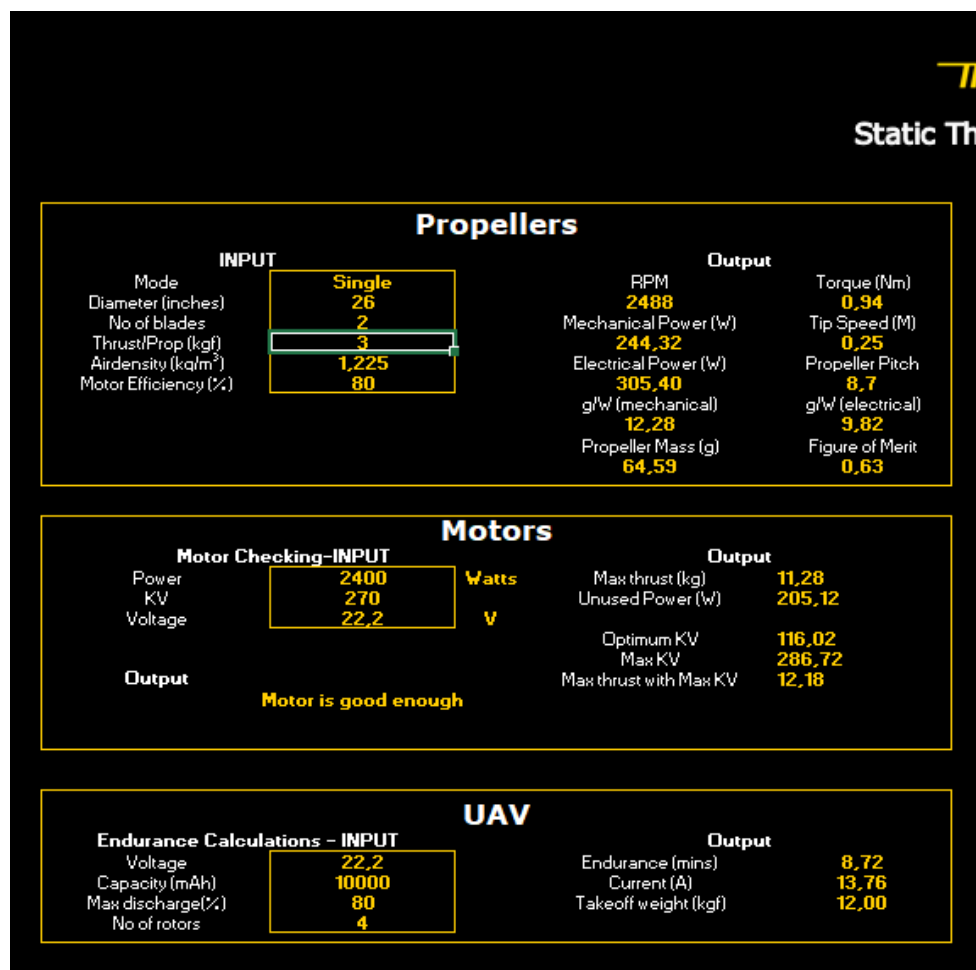
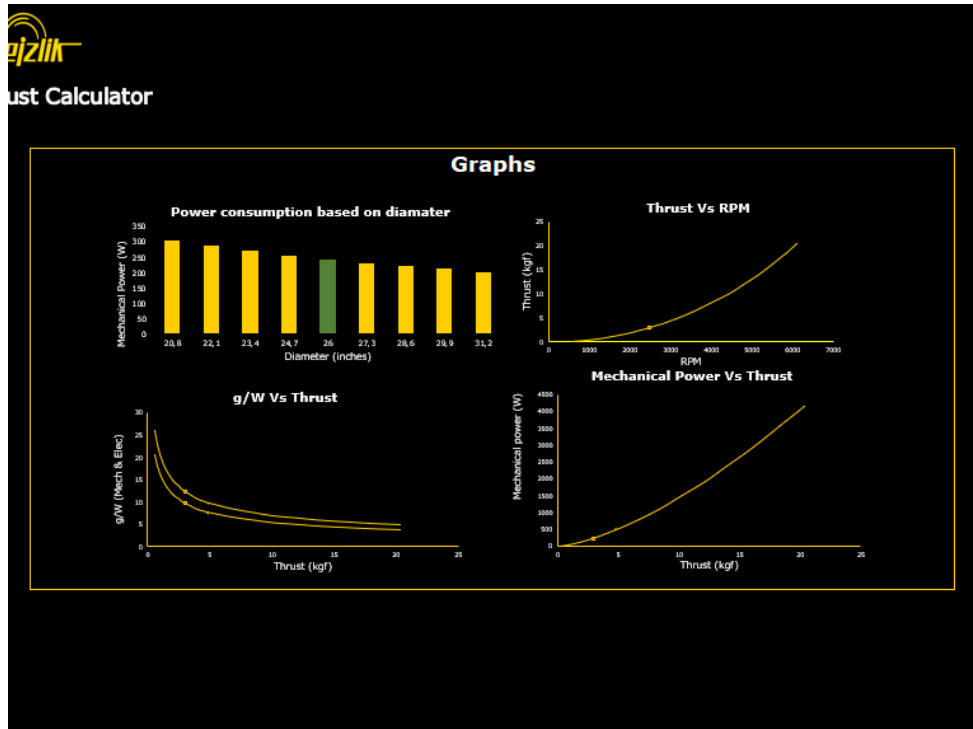

Fig. 2.3. Parameters of the drone calculated from better estimations. [5]





**Fig. 2.4.** Graphics of the performance of the drone from better estimations. [5]

This provides a more realistic approximation of the endurance, that is 8.72 minutes long. It is sufficient for the purpose of the drone, considering that it only must do the way once, it does not have to come back.

## 2.2 Choices of the electronic components

The components chosen are the following:

### 2.2.1. Propeller: Mejlzik 26x8.7

It is chosen a 26-inches-propeller, as result of several iterations. The manufacturer is Mejlzik [5], because it was the brand whose calculator that was used, so the results are in accordance with their propellers. All the specifications are in Table 2.2.

**Table 2.2** Propeller specifications

PN	2260873
Material	Carbon fiber, glass fiber, roving, polyurethane, epoxy
Weight	66g ( $\pm 10\%$ )
Brand	Mejlzik
Central hole	$\varnothing$ 10mm - hole size can be increased or reduced based on the requirement.
Mounting pattern	mounting holes can be drilled up to $\varnothing 32$ mm (2x bolts), $\varnothing 24$ mm (4x bolts) diameter
Diameter	26" (660.4 mm $\pm 1\%$ )
Pitch	8.7" measured at 75% of propeller blade
Maximal RPM	6900 RPM (0.7 Mach)
Working Temp	-40 °C up to +65 °C

[5]

This is how the propeller looks like (Fig. 2.5.). Obviously two clockwise and two counterclockwise, might be aquired, like in every drone.

**Propeller:26 x 8.7 P PN:2260873**

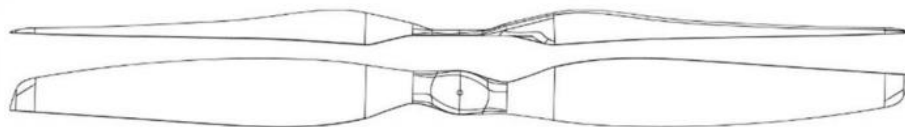

**Fig. 2.5.** Propeller Mejlzik 26 inches. [5]

To sum up, the propeller is much bigger than racing drone's propellers, but it is easy to understand that they are needed to carry some weight.

### 2.2.2. Motor: PROPDRIVE v2 5060 270KV

Attending to the power that the propeller needed, output by the calculator, it was finally chosen this model, because it was the one that provided the best maximum thrust per propeller for the quadcopter. The motor specifications are on Table 2.3.

**Table 2.3** Motor specifications

Model	PROPDRIVE v2 5060 270KV
Brand	PROPDRIVE
KV	270 (rpm/V)
Max current	90A
ESC	100A
Cell count	6s~8s Lipoly
Pole Count	14
Bolt holes	25mm
Bolt thread	M4
Shaft	6mm
Connectors	4mm Bullet
Weight	438g
Connector type	XT90-S
Balance connector type	JST-XHR
Max current (motor)	90A
Resistance	36mh
Max voltage	29.60V
Power	2400W
Shaft A	6.00mm
Length B	58.90mm
Can diameter C	50.00mm
Can length D	38.00mm
Total length E	85.00mm

[6]

Multiplying max current per max voltage, the result (max power with 100% of efficiency) is 2664W, but the specification says that the maximum power is only 2400W, so efficiency can be output from here, dividing the mechanical one (2400W) between the electrical one (Max voltage per max current, 2664W). The result is an efficiency of 0.9. This is a useful information and a good new because it was estimated 0.8 in the calculator, so it will get normally better results than expected.

The measures that are in Table are referred in Fig. 2.6.:

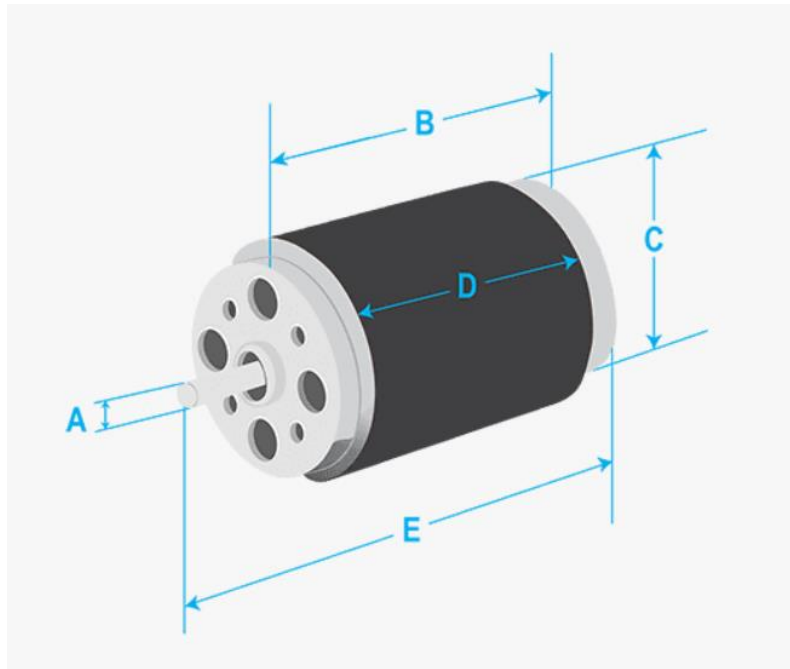

**Fig. 2.6.** Annotation of measures of the motor selected. [6]

The motor looks like the following pictures (Fig. 2.7. and 2.8.):



**Fig. 2.7.** Motor selected. [6]



**Fig. 2.8.** Motor selected reverse view. [6]

Then the assembly will be commented, but the motors come directly with its own assembly equipment, so the end of the arms may be done to fit with this basis (Fig. 2.9.):



**Fig. 2.9.** Selected motor fixing elements. [6]

This motor can not work with bigger propellers because it would work over its maximum power, and it would damage it. The unused power when we are in the maximum thrust (fig) it is close to zero in comparison with its maximum power (2400W), so it can not be used almost any smaller motor, and if it is used a more powerful one, it would be working under its possibilities.

### 2.2.3. Battery: Gens ACE Tattu 6s 22.2V 10000mAh 30C (XT90-S)

The specifications of the battery are below, in Table 2.4.

**Table 2.4** Battery specifications

SKU	TA-30C-10000-6S1P-XT90-S
Weight ( $\pm 10g$ )	1357
Brand	Tattu
Capacity	10000 mAh
Discharge rate (C)	30C
Voltage	6S (22.2V)
Width ( $\pm 5mm$ )	175
Height ( $\pm 5mm$ )	65
Depth ( $\pm 5mm$ )	58
Cable	10 AWG
Cable length (C/D)	65mm/150mm
Connector type	XT90-S
Balance connector type	JST-XHR

[7]

Notice that its weight is heavier than was estimated, but it is not a problem because it was set extra weight in the calculator for preventing these errors in the approximation.

The battery looks like below (Fig. 2.10.):



**Fig. 2.10.** Battery selected. [7]

The manufacturer of the motor chosen recommends a 6S or 8S battery, but 8S is too much voltage to the motor and propeller combination chosen, because the propeller is too big, and the motor would be working over its maximum power. To use this motor with an 8S battery it is needed to reduce the propeller size, but this would decrease more the endurance, so choosing a bigger propeller size and a 6S battery is worthier. 8S batteries are also heavier and much more expensive, and to use it was needed to choose a bigger motor, what will increase motor and battery weight. These are the

reasons for choosing a 6S battery, because it gives the drone a voltage appropriate, and the endurance is enough.

#### 2.2.4. Turnigy Plush-32 100A (2~6S) Brushless Speed Controller w/BEC

The ESCs (Electronic Speed Controller) receive the signal from the autopilot and send the power supply required to the motors. They are separated from the rest of electronic components because of its direct relation and relevance that they have with the motors. Despite of the rest of electronic components such as the Autopilot, GPS, Radio Receiver or camera, it is very important that the electrical ESC specifications are in the adequate range or the ESCs and motors can be damaged. The difference between these components and the rest of electronic components is that the rest must fit in electrical specifications that are normally the same, but the main problem of the choice is about control system, signal, accuracy, resolution and other features.

The ESC chosen has a lot of programming options and features that are not important for the mechanical part of this analysis, so it will be shown only the specifications that concern the thesis in Table 2.5.

**Table 2.5** ESC specifications

Brand	Turnigy
Constant current	100A
Burst current	140A
Battery	2-6S Lipoly
Input Voltage	8.4 to 25.2 V
Bec Output	5.5V / 5A
Motor Type	Brushless
Receiver connection	Standard JR type
Size	50.5 x 31.5 x 20 mm
Weight	84.5g

[6]

The manufacturer of the motor recommends a 100A ESC and knowing that it is used the less voltage that the motor can use, the drone is able to use almost the maximum power in max thrust situation, and that power is voltage multiplied per current, it can be expected that the current will be as high as the manufacturer says that the motor resist. Doing a quick calculation, max electric power (2664W) divided into the voltage we are using (22.2V), gives us a result of 120. This ESC resists a constant current of 100A, but a burst current of 140A. Burst current is stood during about 10 seconds, so the maximum possible current can damage the ESC if it is reached for a long time. It is usual to fly in these conditions, because like in conventional cars, rarely you press the full throttle.

The ESC looks like in Fig. 2.11.:





**Fig. 2.11.** ESC selected. [6]

## 2.2.5. Rest of electronic components

The rest of the components that are chosen has very few importance at mechanical level. They are going to be shown in a short way and focalise in the main things that important to this thesis: size, weight and assembly.

These components are as important as the mechanical ones (propellers, motors, battery an ESCs) for a good working of the drone, but they do not have mechanical influence at first level.

### -Autopilot

The autopilot chosen is the Pixhawk 4. Pixhawk is one of the top firms of autopilot for this type of vehicles and it is compatible with a lot of the existing components. This model is not the last that is available, but it is famous because of its well running.

The Pixhawk 4 pack that I will choose includes:

- Pixhawk Autopilot
- GPS Ublox NEO-M8N with compass
- Pixhawk 4 Power Module (PM07)

The Pixhawk PX4 is an autopilot with open code mainly used in radio-control multicopters and planes. Its processor is a 32 bits ARM Cortex running under a NuttX RTOS. It has 14 PWM/servo outputs (8with failsafe and manual control and 6 auxiliars, compatibles with high power), and some additional connectivity options like UART, I2C, CAN. It has integrated backup file to automatic autopilot and manual mode, external security button for motor activation, multicolour LED indicator, indicator of high power and multitone. It also has SD card for high task registering during long terms.

The main specifications of the system for the purpose of the thesis are the following, in Table 2.6. The rest can be easily found looking for its datasheet:

**Table 2.6** Autopilot specifications

Brand	Pixhawk
Model	Pixhawk 4
Power Module Output	4.9-5.5V
Max Input Voltage	6V
Max current sensing	120A
USB Power Input	4.75-5.25V
Servo Rail Input	0-36V
Weight	15.8g
Dimensions	44 x 84 x 12 mm
Operating temperature	-40C to 85 C

[8]

The autopilot needs a BEC to convert the 22.2V that provides the battery to 5V current, but there is a pack that includes one and the GPS too, and the facilities to assembly it. Figure 2.12. shows how does the Pixhawk 4 looks.



**Fig. 2.12.** Autopilot selected. [8]

Connecting every peripheral to this autopilot is very easy because every port has written down its use and it has its own instructions manual.

**-GPS**

The GPS, as in another vehicles, is for knowing the position of the quadcopter anytime.

The GPS we chose is the most recommended by the manufacturer of the autopilot: Holybro M8N GPS. The M8N GPS has an UBLOX M8N module, IST8310 compass, tri-color LED indicator, and a safety switch. This module ships with a baud rate of 38400 5Hz. It comes with a protective case. Its specifications are in Table 2.7.:

**Table 2.7** GPS specifications

Brand and model	Ublox Neo-M8N module
Antenna size	25 x 25 x 4 mm ceramic patch antenna
Current consumption	<150mA, 5V
Cable length (included)	26cm
Total Diameter	50mm
Weight (with case)	32g
Operating temp	-40C to 85 C

[9]

We must take care of the positioning and frequencies of the GPS, the telemetry and the receiver to avoid interferences.

The GPS can be placed with or without antenna. With antenna seems like below, in Figure 2.13.



**Fig. .2.13.** GPS selected. [9]

As it was said with the autopilot, the rest of specifications can be found researching its datasheet. The box includes the assembly facilities to fix it to the Pixhawk and some different connectors that can be needed.

#### -Power module

We need a power module that converts 22.2V supplied by the battery to the 5V that must arrive in the autopilot. This component has an internal circuit called BEC.

We have chosen the Pixhawk 4 PM7, the one that recommends the autopilot manufacturer, because it is in the box when you buy it. There are many possibilities, but the only purpose of this element is that I mentioned before, so the difference between this and other is the quality and security of its components. Separately, this has a medium price compared with others, and it is enough to accomplish its function.

Its main specifications are in the Table 2.8. The rest of them, as in the elements seemed before, can be found in its datasheet, but are not of our field of study.

**Table 2.8** Power module specifications

Brand and model	Pixhawk 4 PM7
UBEC output current	3A
UBEC output voltage	5V
UBEC input voltage	7 – 51V (2 – 12S LiPo)
Dimensions	68 x 50 x 10 mm
Weight	47.5g
Mounting Holes	45 x 45 mm

[9]

As the GPS, it includes the facilities to assembly it to the autopilot. The power module station comes with some wires with different connectors to fit with the battery connector, as Fig. 2.14. shows.

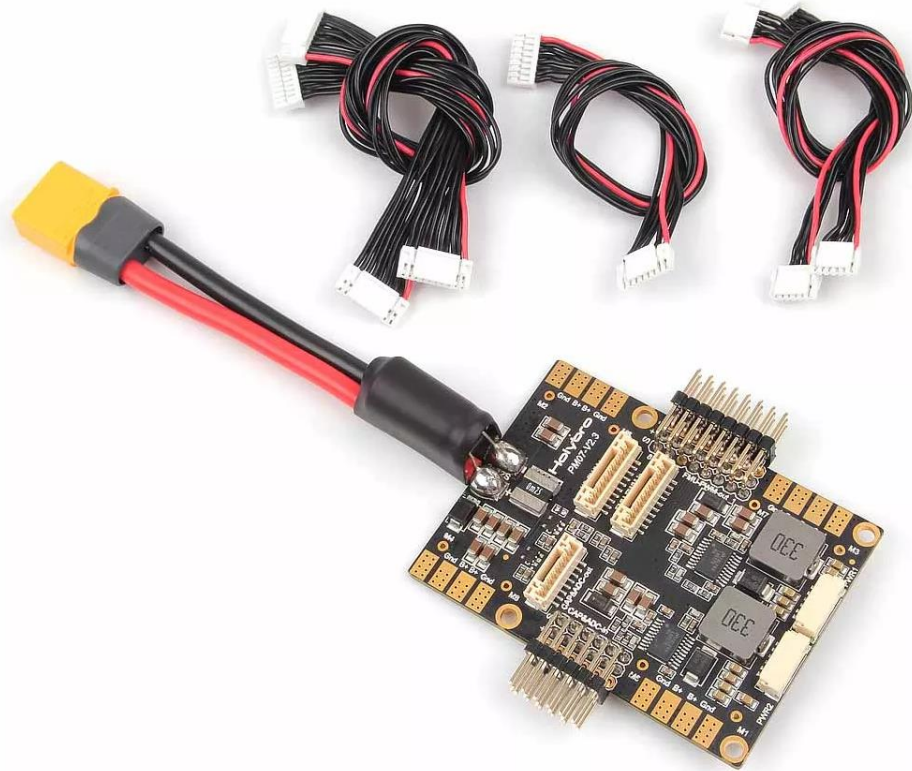

**Fig. 2.14.** Power module selected. [9]

As it is shown in the figure, this component is not only a BEC, but also a power module station with another components and another functionality that is to show the quantity of electric charge of the battery. The details of the configuration are, like in the autopilot and the GPS, out of the competence of this thesis, and are shown in its manual.

### -Receiver

The receiver is the element that catches the signal of the Radio Control System (Transmitter) and send it to the Autopilot. It was chosen the transmitter Turnigy Evolution PRO Digital AFHDS 2A Radio Control System, and it includes the receiver that will be used: the Turnigy iA6C PPM/SBUS 8CH 2.4G AFHDS 2A Telemetry Receiver.

Its main specifications are in the Table 2.9:

**Table 2.9** Receiver specifications

Brand and model	Turnigy iA6C PPM/SBUS 8CH 2.4G AFHDS 2A Telemetry Receiver
Frequency	2.4GHz ISM Frequency Range
Band width	500KHz
Band quantity	135
RF Power	<20dBm
System	AFHDS2A
Output data	PPM, i.BUS, S.BUS
Antenna length	26mm
Power	4.0V – 6.5V
Wireless Update	Yes
Net weight	7.9g
Dimensions	41 x 25 x 10mm
Range	>300m

[7]

It also has battery monitoring and connection ports for use with optional telemetry sensors, as it is seen in the Fig. 2.15.



**Fig. 2.15.** Receiver selected. [7]

Interference problems are solved in nowadays devices, so it will not be a problem to place the receiver closer to the GPS.

-Transmitter.

This component is not really integrated in the drone but is fundamental for its control and has to be compatible with the receiver and the autopilot. The model that was chosen is the Turnigy Evolution PRO Digital AFHDS 2A Radio Control System, but its specifications will not be explained because the electrical ones are not the main of the thesis, and the mechanical ones are not integrated in the drone. They can be easily found in its datasheet.

In Fig. 2.16. we can see how does it like.



**Fig. 2.16.** Transmitter selected. [7]

A transmitter with a monitor was chosen to see what the drone sees with its camera.

**-Camera**

It was chosen the 800TVL CMOS Camera mainly because it is very small and light and can send the image in real time to the monitor of the Radio Control System.

Here can be found the mechanical and electrical specifications in Table 2.10 and in Fig. 2.17., how it looks. Rest of the specification can be found in its datasheet.

**Table 2.10** Camera specifications

Size	26.6 x 26.6 x 29.8mm
Weight	11.3g
Working Voltage	DC 5V – 9V

[10]





**Fig. 2.17.** Camera selected. [10]

It includes a mount bracket, a suspension bracket for turbulence and its instructions manual.

## 2.3. Design of the frame and dynamic calculations

### 2.3.1. Designing the frame

The frame will be composed by four parts: a lower cover, the frame that keeps the battery, an intermedium cover that holds the components and the upper part, that works as a cover and includes the arms too. The whole drone is represented in Fig. 2.18.:

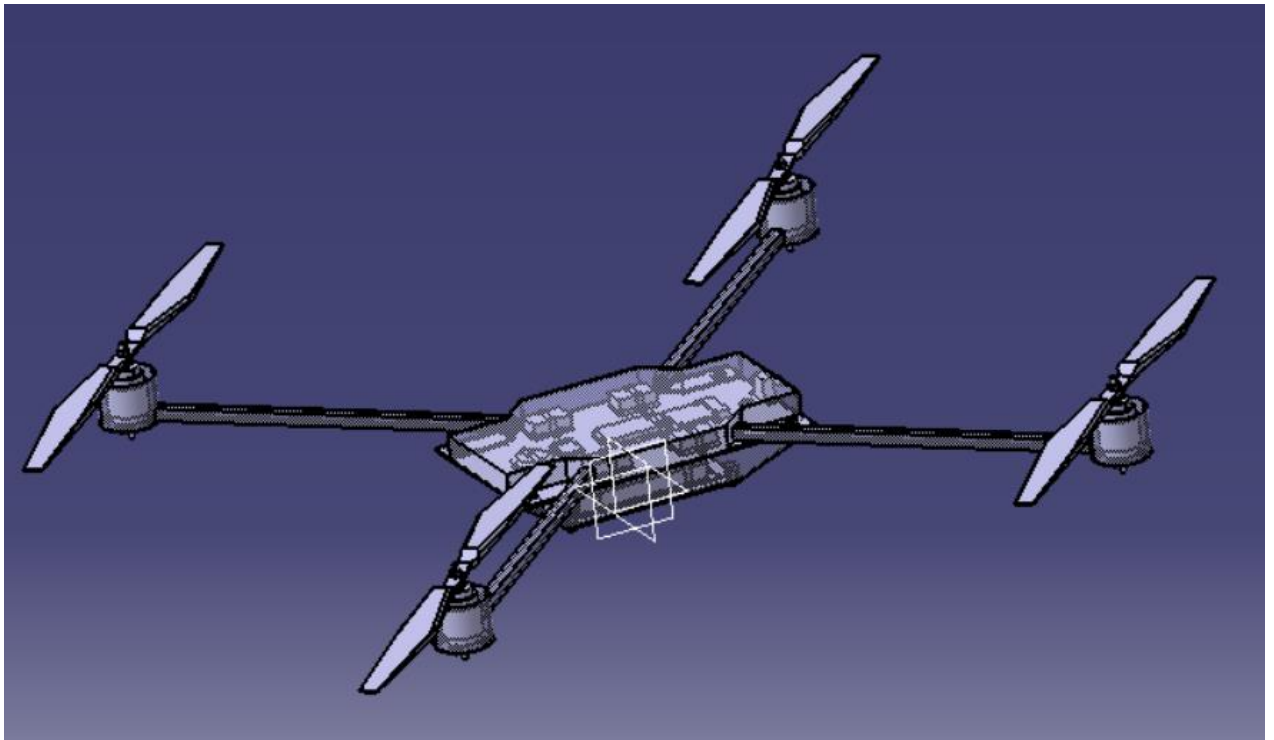
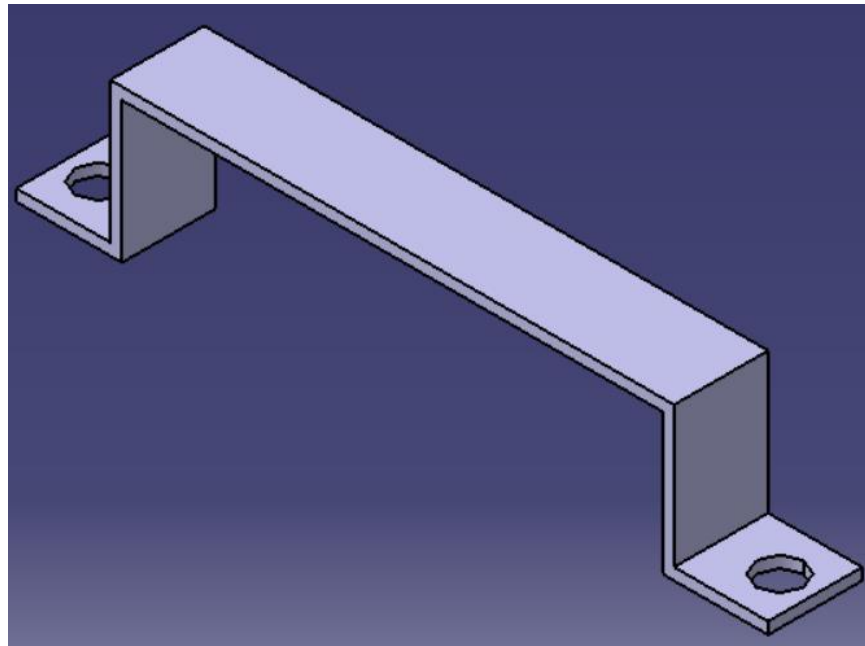

**Fig. 2.18.** 3D view of the drone.

The upper part includes the arms, so they will be printed together.

The lower cover is for changing the battery or charging it when it is necessary. The battery will be fixed to it with the pieces that we saw before.

The intermedium cover is to put on the power module, the autopilot, the receiver, the GPS, the camera and the ESCs, holding all of them. It goes between the lower part of the frame and the upper part of the frame. All these components except for the camera, that has its own fixing pieces, are fixed to the basis with some pieces that are seen below (Fig. 2.19.). The battery is also fixed with this type of components. They are similar one to the other, but they are done specifically for each component.



**Fig. 2.19.** Fixing part.

The upper part of the frame has the purpose of protecting the components that are set on the intermedium cover.

The intermedium cover has the necessary hole for the wires that connect the battery to the power module.

The arms, that are part of the upper part of the frame, are hollow for holding the wires that connect the ESCs with the motor. The ESCs are not symmetrically situated in the basis; because they are used to equilibrate the centre of mass in the x axis, that was not at the centre of the drone because of the distribution of the electronic components, that were situated as well as is possible for not disequilibrating it much, so the result is that the centre of mass of the drone is now in the middle point of the drone.

The motors are fixed to each end of the arms, with the fixing gear that is included in them (screws and nuts too).

Each propeller is fixed to each motor with the mechanism that is prepared for it. Propellers' centre hole diameter must be increased to fit in the motors' fixing mechanism.

The parts of the frame will be manufactured with a 3D printer in ABS. Once all the parts of the frame are designed, the total weight of the drone can be calculated, and calculations about maximum thrust, endurance, etc., can be done. After this, internal stress tests will be done to be secure that the geometry of the frame is suitable.

### 2.3.2. Total weight, endurance and maximum roll and pitch

-Total weight:

Setting in Catia (the program that pieces are designed with), the density of the ABS, it can be checked the weight of each piece, because the program calculates the volume of material that is used in the piece and outputs the mass too. The list of weight is in Table 2.11.

The wires are included in the weight of each component.

**Table 2.11** Weight of the components

Component	Weight
Battery	1357g
Motors	4x438g
Propellers	4x66g
ESCs	4x84.5g
Power Module	47.5g
Autopilot	15.8g
Receiver	7.9g
GPS	32g
Camera	11.3g
Battery Cover	77g
Battery Frame	256g
Cover with arms	679g
Component holder basis	211g
Power module fixers	2x0.11g
Autopilot fixer	0.73g
ESC fixers	4x0.76g
GPS fixer	0.74g
Receiver fixer	0.53g
Battery fixers	2x2g
Threaded shank	91g
Bolts and nuts	12x3+38x1+8x9+38x0.87+6
Carry capacity	2000g
<b>Total</b>	<b>7334g</b>

[5] [6] [7] [8] [9] [10]

The final weight is higher than expected because some components like the ESCs or the battery are heavier than it was thought at first, and the frame too. Below it will be calculated the position of the centre of mass, the maximum thrust of the quadcopter, the endurance and the maximum pitch and roll. In the Fig. 2.20. it is shown the parameters that outputs the calculator, but they will be also calculated manually to check them.

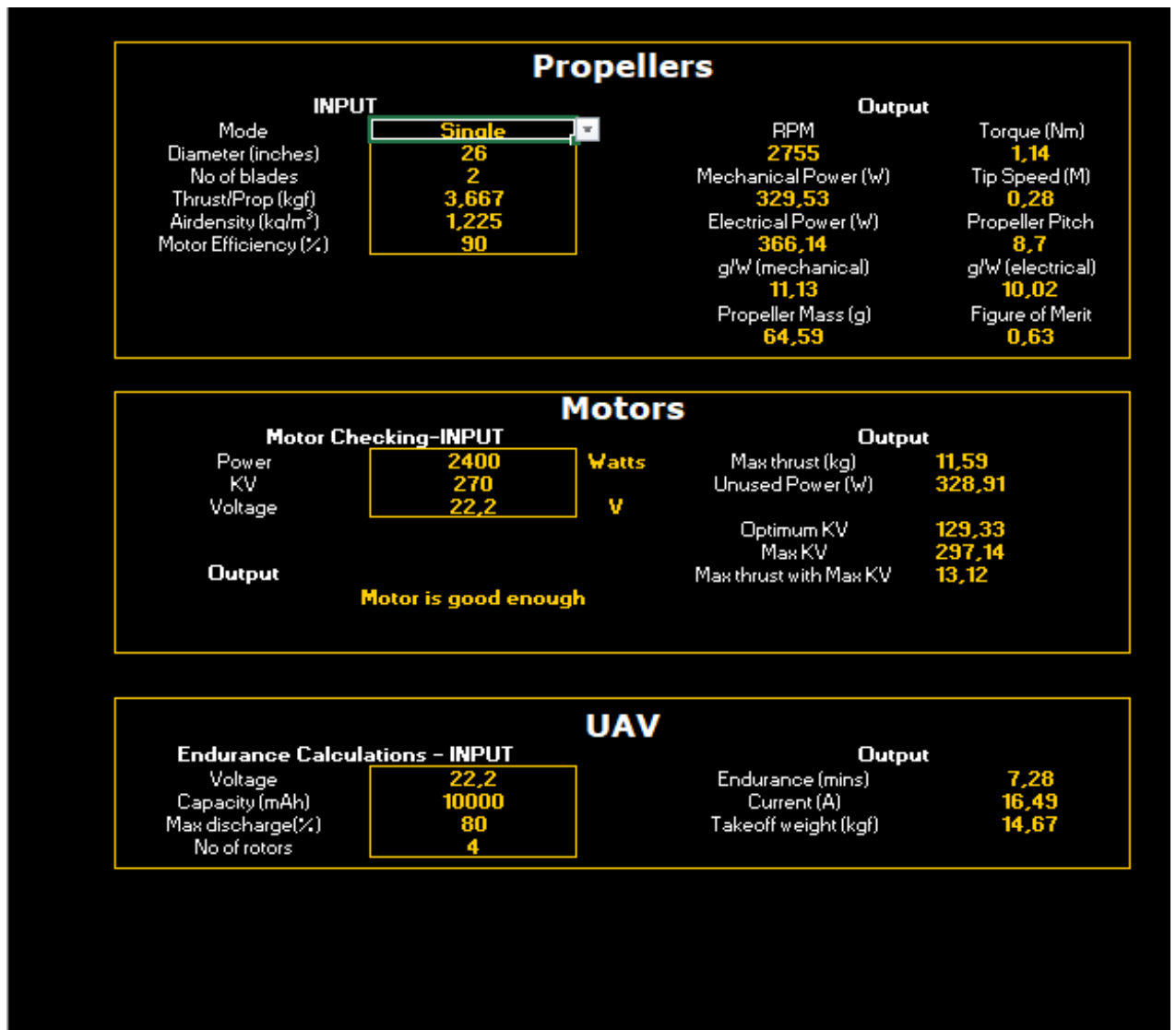

Fig. 2.20. Parameters output by Mejlzik calculator. [5]

-Centre of mass:

The components are distributed to keep the centre of mass in the centre of the drone. Most of the pieces are bisymmetrical, other like motors and propellers are situated in bisymmetrical points, and the electronic components that are over the component holder are located to keep the centre of mass in the middle axis.

Using equation (2.1) it will be placed the centre of mass:

$$centre\ or\ mass = \frac{\sum(W \cdot d)}{\sum W} \quad (2.1)$$

where:

- W – Weight of the component, in kg.
- d – distance to the left side, that is the origin of coordinates.

In Fig. 2.21. we can see the distribution of the electronic components that are being mentioned. The centre of mass may be at 200mm from the left side, that is the middle point of the drone. In the other direction the components are placed symmetrically to get it in the middle directly.

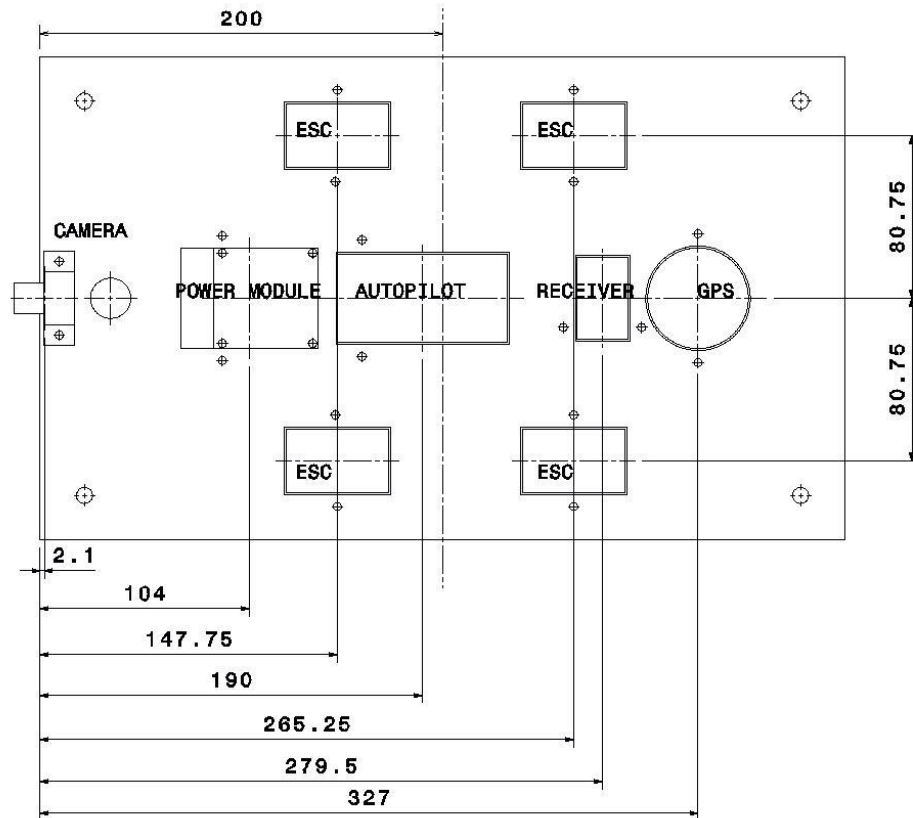

**Fig. 2.21.** Electronic components distribution.

Solving equation (2.1) the result is 200, because the place of the ESCs was set as an unknown quantity to place them in the right place for equilibrating the drone, and setting the result in 200mm, the place where the centre may be.

-Endurance:

The endurance of a quadcopter is calculated following the equation below as it is said in the following equation [11]:

$$time = capacity \cdot discharge / AAD \quad (2.2)$$

where:

- Time - is the endurance time in hours;
- capacity – capacity of the battery in Ah;
- discharge – max discharge fraction of the battery;
- AAD – average amp draw of the drone, expressed in Amperes.

If you do not know the AAD of your drone, it can be calculated as it is said in the following equation [11]:

$$AAD = AUW \cdot P/V \quad (2.3)$$

where:

- AAD – average amp draw of the drone, expressed in Amperes.
- AUW – all up weight of the drone in kilograms.
- P – Power required to lift one kilogram of equipment in W/kg.
- V – battery voltage, in V

The value of P is usually estimated to 170, but the calculator of Mejlík [5] outputs the inverse value for this case, so we can use it to get more accuracy. Changing 10.02g/W (electrical) to W/kg, it is 99.8 W/kg. The all weight up that it is input includes the Power-to-Weight ratio that we used before. Inputting this value into the equation (2.3), and then solving equation (2.2) it is:

$$AAD = 14.668 \cdot \frac{99.8}{22.2} = 65.94A \quad (2.3)$$

$$time = 10 \cdot \frac{0.9}{65.94} = 0.1365h = 8.19min \quad (2.2)$$

This handmade calculation is more optimistic than the endurance that outputs the calculator, but they are similar, so the handmade calculation is trustable.

-Maximum yaw and roll:

This is an important calculation for knowing how much is able to manoeuvre the quadcopter. The distribution of the forces that are actuating over the quadcopter are the weight, thrust, and drag. It is going to be calculated the maximum yaw and roll for the situation of going horizontally, but it will be different if it needs to go up and forward for example, because  $F_y$  must be larger with the same  $F$ , what will cause a decrease of the angle. The reverse purpose (decreasing while going forward) will cause the inverse effect (rise of the maximum angle).

The drag force does not affect to this problem while going in a horizontal direction because it is always in the direction of the movement and against it, so it will be horizontal too. Considering the weight and the resulting thrust of the four propellers, the Fig. 2.22. shows how they actuate in the quadcopter:

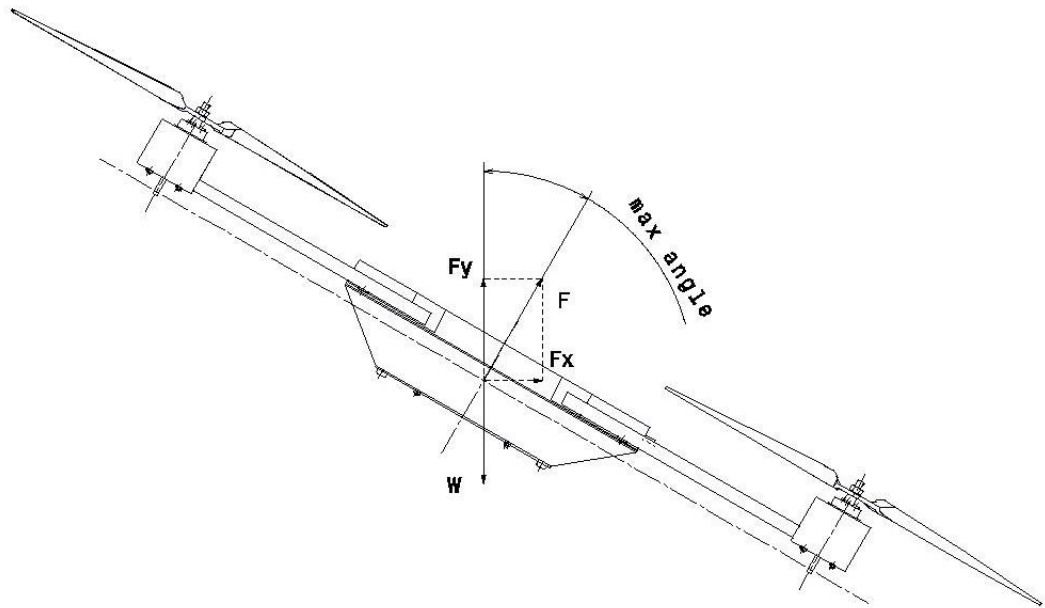

**Fig. 2.22.** External forces at the drone

Using the second Newton's law (2.4) in the vertical direction and establishing that  $F$  (the sum of the thrust of the four propellers) is the double of the weight, that is the value that we used for the inputs of the calculator (using Power-to-Weight ratio), we can find the maximum yaw that the drone can do. The problem is the same for calculating the roll, because the disposition of the forces is the same too.

$$\sum F = m \cdot a \quad (2.4)$$

- $F$  – External forces that actuate in the drone.
- $m$  – Mass of the drone.
- $a$  – Acceleration of the drone.

Applicating it to the vertical direction, and knowing that the vertical acceleration is null:

$$2 \cdot Weight \cdot \cos(\text{max angle}) - Weight = 0 \quad (2.4)$$

Solving it, the maximum angle that the drone can yaw or roll is  $60^\circ$



## **2.4. Technological process**

### **2.4.1. Technological process of the frame**

All the parts that are not standardized or bought directly from a catalogue such as the electronic components will be 3D printed. The upper cover, that includes the arms, is almost 900x900mm size, so it is needed a 3d printer that can print these dimensions. The main reason to not do the arms in a separated parts is that the joining between the cover and each arm is the most solicited in internal stress term (as it will be shown in subchapter 2.5), so it is better to do it in this way for a most accurate study of the internal stresses and for avoiding reaching higher internal stresses in the joins that can damage them.

The material that the parts will be printed is ABS, that is a cheap material with low density that fits well in terms of internal stress limit for the quadcopter. More expensive materials with better features of traction and impact resistance are not necessary, and if the other alternatives have higher density than ABS (like some metals or alloys), there is other inconvenience to choose them added to de higher price.

It is necessary to inspect each part once printed, and manually fix its possible mistakes at printing.

## 2.4.2. How to assembly the drone

The main problem of the drone is not manufacturing the parts but assembling them well. Order is very important to not have problems connecting wires or manipulating some parts that are assembled before it is recommended, because other parts can be damaged as a consequence of this bad manipulation. The correct order for assembling the drone is shown in Table 2.12, step by step:

**Table 2.12** Steps to assembly the drone.

<b>Step</b>	<b>Description</b>
1	Place the electronic components that goes in the component holder basis and the battery in its place in the lower cover and fix them with their fixing parts, M4x8 bolts and M4 nuts.
2	Fix the lower cover with the lower frame with the M8x12 bolts.
3	Connect the autopilot to the components that are in the same basis, like GPS, ESCs, receiver, power module and camera.
4	Connect the battery to the power module station running the cable of the battery through the hole prepared for it.
5	Fix the four threaded shanks to the four motors with the M4x20 bolts.
6	Connect each ESC to its motor running the wires through the arms.
7	Fix the four motors to the cover with arms with the M4x8 bolts and the M4 nuts.
8	Fix the propellers to the threaded shanks with the M8 nuts. Remember to put the clockwise ones at front-left and rear-right and the counterclockwise at front-right and rear-left.
9	Fix the cover with arms with the component holder basis and the lower frame with the M8x12 bolts.

## 2.5. Internal stress test

Taking into account that it is used a not very resistant material to do a big drone with long and thin arms, it is very important to test the geometry of the cover with arms to ensure that it will not brake.

For the test it is going to be used a simulation where over the faces that are fixed the motors will be applied the thrust per propeller that was used for the calculations and fixing the central zone of the part to the floor. This is the force that is estimated from the beginning that we need to manoeuvre the quadcopter.

In the Fig 2.23. and 2.24. is shown the results of the simulation with different scales to comment different aspects:

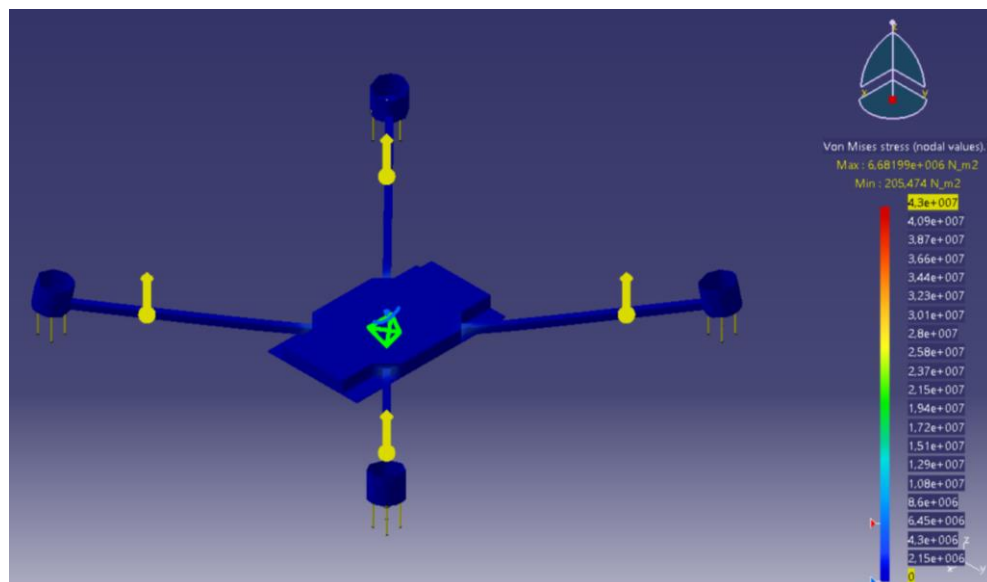

**Fig. 2.23.** Internal stress test, scale 1

In figure , the limit of the scale that is set from zero to the limit of stress that ABS can stand (43MPa) [12]. The most solicited zones, as it was said before, are the joinings between arms and cover. As it is shown in the figure, the stress at this zones is close to 12,9MPa, what it is less than the third part of the stress it can support, so we can ensure that the arms will not break while the drone is flying.

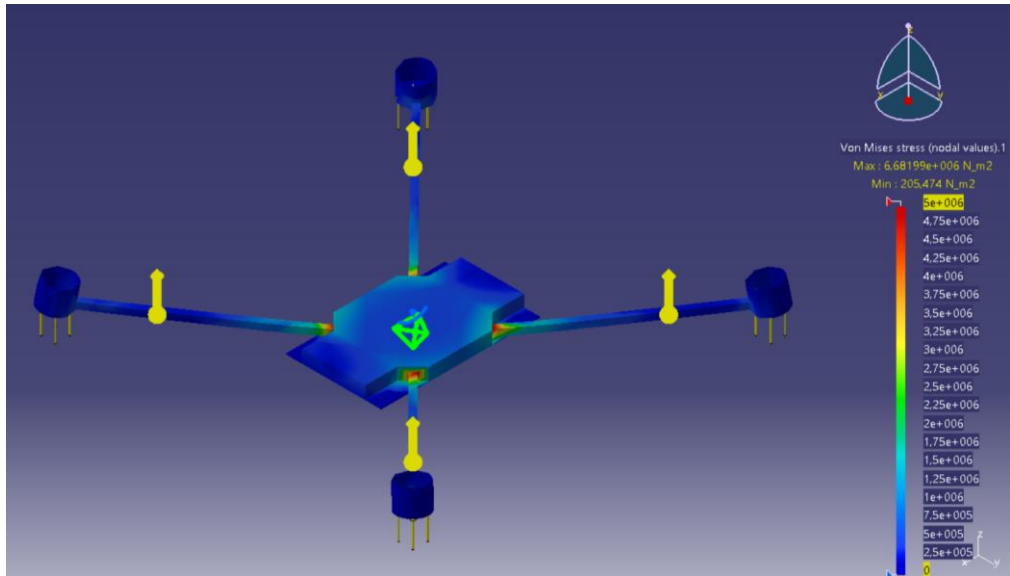

**Fig. 2.24.** Internal tress test, scale 2

At figure, stress scale is set from 0 to 5MPa, to see the distribution of internal stresses along the arms and at the rest of the zones of the part. It shows clearer that the most solicited parts are the arms and how internal stress is not a problem apart from these zones.

### **3. SAFE WORK AND ENVIRONMENTAL PROTECTION REQUIREMENTS**

#### **3.1. Regulations, safety and security**

It is important to appoint the regulations of flying drones, instead of the proposal of the drone is a rescue one, so it will be flown by military or official brigades, because anybody can fly this drone and must know the rules to follow.

The new European regulatory framework applies to all unmanned aircraft, whether autonomous or remotely piloted, and regardless of their mass or use.

It should be noted that military drones, search and rescue drones, police, customs and border control agents, firefighters, coast guards and other security forces and various authorities are exempt.

There are two new regulations to follow:

- Delegated Regulation 2019/945, of March 12, 2019, aimed at regulating the requirements and specifications for manufacturers of unmanned aircraft systems or drones.
- Execution Regulation 2019/947, of May 24, 2019, which regulates the use of unmanned aircraft systems or drones by drone operators and pilots, whether recreational or professional.

As of the application of Delegated Regulation 2019/945, the requirements and technical specifications that drones intended for operations of any kind must incorporate are standardized.

In addition, the systems, applications and accessories that accompany the drone are also included, as well as the safety and navigation information that must be included in the aircraft manuals.

Bearing in mind that this product has been manufactured in compliance with the manufacturer's requirements, this section focuses on detailing all the regulations that the pilot flying the drone must comply with.

The restrictions that must be met by the pilot are:

- During the flight you must never exceed 120 m in height or 50 m in horizontal distance.
- You cannot fly in national parks or protected natural spaces.
- The drone cannot be flown anywhere that is less than 8 km from an airport.
- Civil liability insurance is not compulsory, but it is highly recommended.
- The pilot will be responsible for any damage that the drone may cause.
- It is necessary that the drone has a fireproof identification plate that includes the data of the manufacturer, model and the data of the pilot. This plate will be fixed to the structure of the drone.

It is important to keep in mind that, despite complying with all the rules, you must fly with common sense. In such a way as to guarantee the safety of the airspace and of people. Other important recommendations are not to fly under unfavourable weather conditions and stay informed about possible updates of the restrictions that the state aviation safety agency may implement. [13]

### **3.2. Environmental impact**

In this section, a brief analysis of the environmental impact of the manufacture of the drone will be made. In recent years, 3D printing has brought about a new industrial revolution. 3D printing is a rapidly evolving technology with many advantages over traditional manufacturing methods such as machining, injection moulding, etc.

3D printing consists of manufacturing parts layer by layer using materials such as plastic filaments or resins. Using a laser or heated extruder as a power source, layers of these materials solidify to form the finished part. The advantages of 3D printing include its freedom of form, applications in many industries, precision, speed, and ability to reduce component prices and weight.

Since CNC machining involves working on an initial billet of metal, there will always be scrap later. These pieces of material must be cleaned up later and disposed of, which is avoided when using 3D printing. This makes 3D printing the most sustainable as there is less waste.

3D printing technologies are ecologically interesting for small-scale production (less than 1,000 parts), compared to traditional injection moulding technology. Regardless of the quality of the 3D printer used, the environmental impact of 3D printing is lower at production volumes of less than 300 replicas. In addition, it represents savings in transport, since the amount of material needed to manufacture the same piece is much less than if it were mechanized.

From an environmental point of view, saving resources comes both from the selection of materials and from the amount of material used in production. It should also be borne in mind that with 3D printing it is not necessary to manufacture moulds for the subsequent manufacture of the parts, so this also represents considerable savings and a more sustainable manufacturing process.

It is true that 3D printing emits various particles and gases such as carbon monoxide and hydrogen cyanide, among other volatile compounds. However, it should be noted that according to several studies that have been carried out, these emission levels are equivalent to those of cooking in a low-power gas or electric oven, so it does not have drastic environmental consequences.

Lithium batteries are the most polluting element of the drone of this project. That is why we have tried to reduce the weight of the drone as much as possible, avoiding metal and working with ABS, in order to extend the life of these. In this way, the contamination that can cause the destruction of these lithium batteries is considerably reduced. This aspect is of the utmost importance in the space industry, since it represents substantial energy savings. [14] [15]

## 4. ECONOMIC CALCULATION

### 4.1. Project cost calculation

This section is for estimating the cost of producing a drone, considering, apart from the pieces, resources for manufacturing and assembling it.

In the table 4.1 are shown the catalogue parts. These parts are directly bought from the manufacturer to implement them in each drone.

**Table 4.1** Catalogue parts costs

Nr.	Item	Quanty	Price/Unit (Eur.)	Total (Eur.)
1	Propeller CW 26''	2	120.22	240.44
2	Propeller CCW 26''	2	120.22	240.44
3	Brushless Motor	4	75.54	302.16
4	ESCs	4	44.57	178.28
5	Battery	1	199.99	199.99
6	Autopilot	1	177.06	177.06
7	GPS	1	45.66	45.66
8	Power Module	1	39.14	39.14
9	Receiver	1	10.14	10.14
10	Radio Control System	1	67.65	67.65
11	Camera	1	39.81	39.81
Total (Eur.)				1540.77

[5] [6] [7] [8] [9] [10]

The stock needs are reflected in table 4.2. There is only one, ABS, for manufacturing the pieces of the drone that are printed in 3D. Knowing the weight of each part, they can be summed all and output the total weight of ABS that is needed for manufacturing a drone. It will be taken into account a waste of 8% of the material needed per drone.

**Table 4.2** Stock materials costs

Nr.	Item	Quanty	Price/kg (Eur.)	Total (Eur.)
1	ABS	1.331kg	20€/kg	26.62€

[16]

The table 4.3 shows the cost of the standard parts: bolts and nuts. These pieces are sold in packs, so here is reflected the price per unit, dividing the total price of the pack per the number of units per pack.



**Table 4.3** Standard part costs

Nr.	Item	Quanty	Price/Unit (Eur.)	Total (Eur.)
1	Screw M4x8 ISO 1207	38	0.56	21.28
2	Screw M4x20 ISO 1207	12	0.62	7.44
3	Screw M8x12 ISO 1207	8	0.47	3.76
4	Nut M8 ISO 4032	38	1.4	53.2
5	Nut M4 ISO 4032	4	0.62	2.48
Total (Eur.)				88.16

[16] [17] [18]

The sum of all the supply costs is in table 4.4.

**Table 4.4** Total supply costs

Nr.	Item	Total (Eur.)
1	Catalogue parts	1540.77
2	Stock parts	26.62
3	Standard parts	88.16
Total (Eur.)		1655.55

The total cost of the supplies is 1655.55€. Transportation costs will be estimated as the 15% of the supply costs, because some components come from U.S.A, so the transportation costs will be:

$$Ct = Sc \cdot 0,1 \quad (4.1)$$

where:

- $Ct$  is the transport costs;
- $Sc$  – is the supply costs;

Resulting in a value of  $Ct= 248.33€$ .

Now it is going to be calculated the costs of equipment and manufacturing. It will be needed a 3D printer that fits the biggest piece that is over 900x900mm, and some tools for getting the drone ready to fly. The equipment costs will be thought for 10 years that it what is estimated it will be needed to replace it. They are shown in tables 4.5, 4.6 and 4.7.

**Table 4.5** Equipment costs

Nr.	Item	Quanty	Price (Eur.)	Total (Eur.)
1	3D printer machine	1	15000	15000
2	Inspection tools	1	50	50
3	Assemble tools	1	300	300
Total (Eur.)				15350
Total/year (Eur.)				1535

**Table 4.6** Manufacturing costs

Nr.	Item	Quanty	Price/Unit (Eur.)	Total (Eur.)
1	Examining	1	10	10
2	Rabbeting	1	20	20
3	Assembling	1	30	30
4	Calibration	1	30	30
Total (Eur.)				90

The costs of the working of the machine are shown in table 4.7.

**Table 4.7** Operation costs

Nr.	Item	Quanty	Price/Year (Eur.)	Total (Eur.)
1	Electricity	1	200	200
2	Personal	1	2500	2500
3	Security equipement	1	60	60
4	Unpredicted costs	1	150	150
Total (Eur.)				2910

Estimating that the 3D printer is able to do the pieces for one quadcopter in one day, and discounting non-working days, and some days of reparation, we can expect 250 drones per year.

Dividing the equipment costs and operation costs per year into the 250 drones that are done a year, we can estimate that per drone, **Eq=6.14€ and Oc=11.64€**.

The total cost of the project will be:

$$Ct = Sc + Ct + Eq + Mc + Oc \quad (4.2)$$

where:

- $CT$  is the Total costs;
- $Sc$  – is the supply costs;
- $Ct$  – is the transport costs;
- $Eq$  – is the equipment costs;
- $Mc$  –is the manufacturing costs;
- $Oc$  –is the operation costs;

The total project cost is **2011.66€** per unit.

Net profit is going to be set at approximately the 25% of the unit cost:

$$Np = Ct \cdot 0,25 \quad (4.3)$$

So, the net profit will be **502.915€**.

The market price is the sum of  $Np$  and  $Ct$ , so it will be **P=2514.575€**.

The Fig. 4.1 shows the costs per unit in a pie chart.

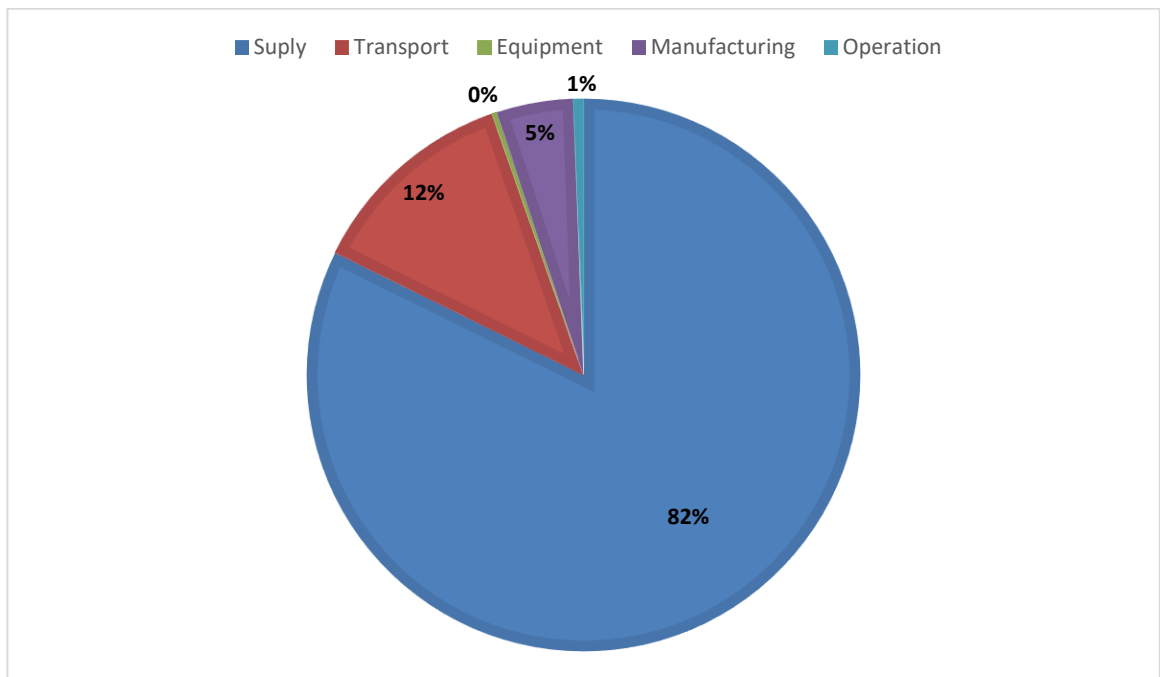

**Fig. 4.1.** Costs per unit

The biggest part of the cost of the drone is the supply cost, because the electronic components are many and expensive, but the manufacturing is not as complex. The equipment cost per unit is insignificant because the equipment does not have to be replaced until several years.

## 4.2. Break even point calculation and payback period

### 4.2.1. Break even point

The break even point is the moment that the revenues are equal to the costs. It means that the level of production to cover the costs is reached.

To find this point is necessary to separate the fixed and variable costs. For the fixed costs related to equipment, it is needed to work with its depreciation:

$$D = \frac{Eq}{t} \quad (4.4)$$

where:

- $D$  is the Depreciation costs;
- $Eq$  – is the equipment costs;
- $t$  – is the time;

It is going to be supposed  $t=4$  years. So, de depreciation is **D=3837.5€**.

Separation of fixed and variable costs is shown in table 4.8

**Table 4.8** Fixed and variable costs.

Fixed Costs per year		Variable costs per unit	
Equip. Depreciation	3837.5	Supply costs	1655.55
Operation costs	2910	Manufacturing	90
		Transpor	148.33
Total (Eur.)	6747.5	Total (Eur.)	1893.88

Then, for indicating the break even point the operating profit is calculated:

$$OP = P \cdot Q - Vc \cdot Q - Total Fc \quad (4.5)$$

where:

- $OP$  is the Operational profit;
- $P$  – is the price per unit;
- $Q$  – is the quantity of units;
- $Vc$  – are the variable costs per unit;
- $FC$  – are the fixed costs per unit;

The break even point is the point that the value of  $OP$  is zero. After that the product starts to be profitable.  $OP$  is set to zero, and the only unknown value is  $Q$ . Solving equation 4.5, the result is **Q=13.417**, so  $OP$  will be positive after selling 14 quadcopters per year.

### 4.2.2. Payback period

For this project the initial investment will be of 30.000 Euros, including all the departments not mentioned in this work as marketing, designing and so on. For the payback period estimation, the following equation is used:

$$PbP = \frac{IV}{Ppy} \quad (4.6)$$

where:

- $PbP$  is the Payback period;
- $IV$  – is the initial investment;
- $Ppy$  – is the profit per year;

To calculation of the profit per year, is necessary to know the EBIT, Earning Before Interest and Taxes, by the following equation:

$$EBIT = P - Vc - Fc \quad (4.7)$$

The variables which are involved here are per unit and have been already defined.

The result is **EBIT=502.915€ per unit**, and estimating an average of 250 units per year, **Ppy=125728.75€**.

Solving the equation 4.6, **PbP=0.2386 years**, and that is **2.86 months**, so at the end of the third month, if it is said in whole months. Fig. 4.2 shows the results.

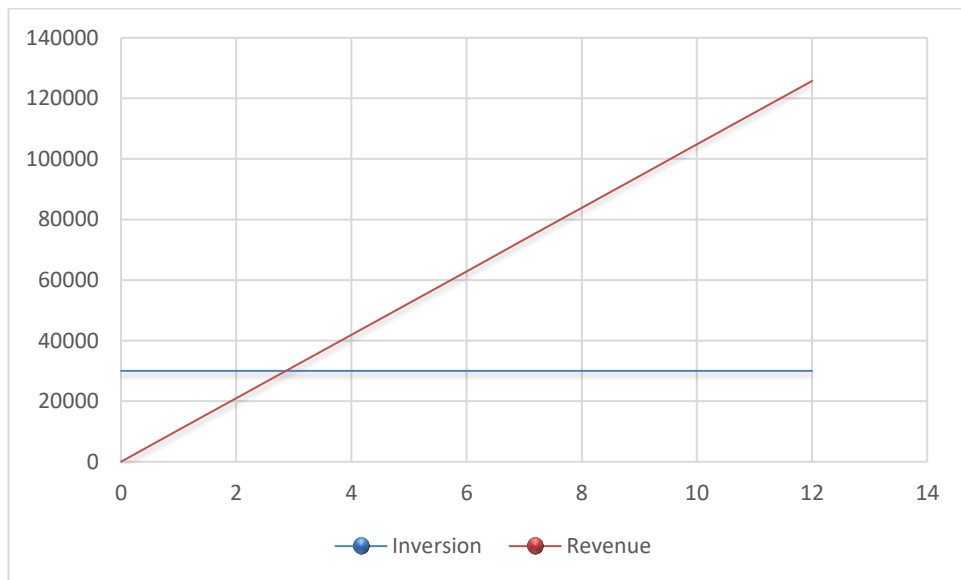

**Fig. 4.2.** Payback period

## CONCLUSIONS

To sum up, some conclusions will be written below. It will focus on mechanical conclusions, that are the main point of this work. The conclusions that can be deduced from this thesis are the followings:

1. X shaped drones are nowadays over + shape drones because with the firsts ones, two propellers are used simultaneously to go in each direction, what provokes a better use of the disponible power.

2. The weight of a drone is directly related to its endurance, and it is very important to try to reduce it as much as possible. Its result is a rise in endurance and a decrease in energy consumed, so it is fundamental to manage it.

3. A correct choice of the battery in terms of capacity, voltage and discharge rate is fundamental to optimise the endurance. The battery is the heaviest component of the drone, and it weight raises a lot with a raise of capacity or number of cells.

4. There are many ways to design the frame, but focusing on the arms, with them integrated in the frame or fixed to it by another mechanism. The choice depends on the material and technical process of manufacturing the frame. In this case it is integrated to avoid high internal stresses in the joins, that are the most solicated zones in this term.

5. Assembly order is very important, because the components are fragile, especially the ones that have sensors. In addition, in this big drone, sometimes it can have a difficult manipulation, so following the correct steps and working in a tidy workspace is fundamental.

6. ABS is an enough resistant material for the design of this drone. There is no need of one that will have a higher price and weight and more difficult manufacturing process of the parts.

## REFERENCES

1. Qiangwu, Z. H. O. U., Shidong, Z. H. U., & Guangyao, C. H. E. N. (2015). *U.S. Patent No. 8,973,861*. Washington, DC: U.S. Patent and Trademark Office.
2. Zhou, J. (2019). *U.S. Patent Application No. 29/621,443*.
3. Colin, Y., Bertrand, B.,g Patron, T., & Pho, V. (2016). *U.S. Patent Application No. 29/487,996*.
4. Cai, Z. (2018). *U.S. Patent Application No. 29/571,429*.
5. Mejlík. <mejlík.eu> [Online]. Available: <https://www.mejlík.eu/> [Last access: 2022]
6. Hobbyking. <hobbyking.com> [Online]. Available: <https://hobbyking.com/> [Last access: 2022]
7. RC-innovation. <rc-innovations.es> [Online]. Available: <https://rc-innovations.es/> [Last access: 2022]
8. Pixhawk 4 user guide. <docs.px4.io> [Online]. Available: <https://docs.px4.io/> [Last access: 2022]
9. Holybro. <shop.holybro.com> [Online]. Available: <https://shop.holybro.com/> [Last access: 2022]
10. SkyRC. <skyr.com> [Online]. Available: <https://www.skyrc.com/> [Last access: 2022]
11. Omniculator <omniculator.com> [Online]. Available: <https://www.omniculator.com/> [Last access: 2022]
12. Wikipedia. <wikipedia.org> [Online]. Available: <https://es.wikipedia.org/> [Last access: 2022]
13. One on air. <oneonair.es> [Online]. Available: <https://www.oneair.es/> [Last access: 2022]
14. 3D Natives. <3dnatives.com> [Online]. Available: <https://www.3dnatives.com/> [Last access: 2022]
15. Impresión 3D. <impresiontresde.com> [Online]. Available: <https://impresiontresde.com/> [Last access: 2022]
16. Amazon. <amazon.es> [Online]. Available: <https://www.amazon.es/> [Last access: 2022]
17. Itools. <itools.com> [Online]. Available: <https://itools.com/> [Last access: 2022]
18. TME. <tme.eu> [Online]. Available: <https://www.tme.eu/> [Last access: 2022]

# ANNEXES

## Annexe 1. Part list General View.

Format	Zone	Position	Mark	Title	Quantity	Remark
				<u>Documentation</u>		
A1		1	MEMK BM 22 01 01 00 00 GV	Quadcopter	1	
				<u>Sub-assemblies</u>		
A1		2	MEMK BM 22 01 01 01 00 AD	Propeller junction	1	
				<u>Parts</u>		
		3		Propeller 26'' clockwise	2	Mejzlik
		4		Propeller 26'' counterclockwise	2	Mejzlik
A4		5	MEMK BM 22 01 01 00 10	Cover with arms	1	
A3		6	MEMK BM 22 01 01 00 11	Component holder basis	1	
A4		7	MEMK BM 22 01 01 00 12	Lower frame	1	
		8		Lower cover	1	
		9		Power module fixer	2	
		10		Autopilot fixer	1	
		11		ESC fixer	4	
		12		GPS fixer	1	
		13		Receiver fixer	1	
		14		Battery fixer	2	
		15		Threaded Shank	1	
			Additional Information	Material, Standard		Scale
Resp. Dept <b>MEMK</b>		Technical Reference		Type of document <b>Specification</b>		Document Status <b>Final Work</b>
VGTU		Created by: <b>Raúl Crego</b>		Title <b>Quadcopter</b>		<b>MEMK BM 22 01 01 00 00 GV</b>
		Approved by <b>Assoc Prof Dr Ina Tetsman</b>			Drawing version <b>A</b>	Release date <b>24/05/2022</b>
					L <b>EN</b>	Sheet <b>1/2</b>





## Annexe 2. Part list Assembly Drawing

Format	Zone	Position	Mark	Title	Quantity	Remark
				<u>Documentation</u>		
A1		2	MEMK BM 22 01 01 01 00 AD	Propeller junction	1	
				<u>Parts</u>		
		3		Propeller 26'' clockwise	2	Mejzlik
		4		Propeller 26'' counterclockwise	2	Mejzlik
		5		Threaded Shank	1	
A4		6	MEMK BM 22 01 01 00 10	Cover with arms	1	
A3		7	MEMK BM 22 01 01 00 11	Component holder basis	1	
A4		8	MEMK BM 22 01 01 00 12	Lower frame	1	
		9		Lower cover	1	
				<u>Standard Parts</u>		
		10		Screw M4x8 ISO 1207	38	
		11		Screw M4x20 ISO 1207	12	
		12		Screw M8x12 ISO 1207	8	
		13		Nut M8 ISO 4032	4	
		14		Nut M4 ISO 4032	38	
				<u>Electronic Parts</u>		
		15		Brushless Motor 2400W 270KV	4	Propdrive
			Additional Information	Material, Standard	Scale	
Resp. Dept <b>MEMK</b>		Technical Reference		Type of document <b>Specification</b>		Document Status <b>Final Work</b>
VGTU		Created by: <b>Raúl Crego</b>		Title <b>Propeller junction</b>		<b>MEMK BM 22 01 01 01 00 AD</b>
		Approved by <b>Assoc Prof Dr Ina Tetsman</b>				Drawing version <b>A</b>

