



Teaching Approaches and Profile Analysis: An Exploratory Study With Trainee History Teachers

SAGE Open
January-March 2022: 1–13
© The Author(s) 2022
DOI: 10.1177/21582440211059174
journals.sagepub.com/home/sgo

Cosme Jesús Gómez-Carrasco¹,
Jairo Rodríguez-Medina² ,
Álvaro Chaparro-Sainz³ ,
and José Monteagudo-Fernández¹

Abstract

The objective of this study is to analyze the teaching approaches of trainee history teachers in Spain. A non-experimental quantitative design was employed with data being gathered via a questionnaire with a Likert-type scale (1–5). Six hundred forty-six students of master's degrees in geography and history teacher training from 22 different universities took part in the study, of whom 358 were men (55.41%) and 280 women (43.34%). The analytical process was performed in four phases. In the first of them, the reliability of the measures was estimated (internal consistency, reliability of the individual indicators, and reliability of the construct). In the second phase, an exploratory factor analysis (EFA) was carried out on the matrix of polychoric correlations between the items. In the third phase, evidence of convergent and discriminant validity was analyzed by way of a confirmatory factor analysis. In the fourth phase, a hierarchical cluster analysis was carried out in order to verify the presence of possible groups and, finally, to ascertain the differences between groups by way of an inferential analysis (ANOVA and Student's *t*). No significant differences were detected in the scoring groups within the Conceptual Change/Student-Focused approach (CCSF subscale) according to the sex of the participants. However, there were significant differences in the Information Transmission Teacher-Focused approach (ITT subscale). A cluster analysis reveals significant differences with regard to the sex of future secondary education history teachers in Spain.

Keywords

history education, teacher training, teaching approaches, hierarchical cluster analysis, secondary education, ATI, sex

Introduction

History classes in secondary education have been configured as a teaching and learning space employing certain practices which are generally assumed by their members (VanSledright, 2014). These practices and routines frequently lead teachers to prioritize certain learning objectives over others (Voet & De Wever, 2020). Pupils, particularly those who are more academically successful, adopt the forms required of them by the teaching community to read, memorize, think, and write in the expected manner (Nokes, 2017). The activities proposed in history classes, the everyday interaction with teachers and the procedures and techniques of evaluation proposed by the teacher reinforce the reproduction of practices (Gómez Carrasco et al., 2020) which are nourished by two models, one epistemological and the other methodological.

The first of these models is that of General Histories, an approach to history teaching designed in the 19th century which aims to show all historical events in chronological order, be they of a nation/state or of the whole of humanity. This model is principally based on the national narrative accepted and promoted by the institutions of power, eclipsing other alternative narratives (Ender, 2019; López-Facal, 2014). The second of the models originates from a

¹University of Murcia, Spain

²University of Valladolid, Spain

³University of Almería, Spain

Corresponding Author:

Álvaro Chaparro-Sainz, University of Almería, Carretera Sacramento s/n, 04120 La Cañada de San Urbano, Almería 04120, Spain.
Email: alvarocs@ual.es



methodological tradition which understands the practice of teaching as the mere reproduction of knowledge, built outside of the classroom, which the teacher must contextualize (Merchán, 2011). Therefore, changing these epistemological and methodological conceptions in initial teacher training is a key element in modifying these hegemonic routines (König et al., 2017).

Approaches to Teaching Inventory as a Tool for Understanding Teaching Approaches

In order to ascertain the approaches employed by teachers, the Approaches to Teaching Inventory (ATI) questionnaire was designed and developed in the United Kingdom (Trigwell & Prosser, 1996). Based on transcriptions of interviews with university teachers and the reliability analysis of factors and scales of elements selected from the inventory, the ATI is a valid and trustworthy relational tool for measuring key aspects of the variation in the way in which teachers see and approach their teaching (Trigwell & Prosser, 2004).

The need to improve the quality of education at all levels has increased considerably in recent years with a view to achieving better learning among pupils. Therefore, emphasis has been placed on optimizing the quality of the teaching provided by teachers. Teachers' knowledge of the way in which they approach their teaching and how this influences their pupils' learning makes the ATI a tool which could lead to a change toward an educational system with a higher degree of excellence (Trigwell & Prosser, 2004).

The definition of teaching approach is related with the way in which teachers teach in relation with their idea of what it means to teach the subject in question. It is, therefore, linked with the epistemology and methodology they follow. The descriptions of Postareff et al. (cited in Yunga-Godoy et al., 2016), Trigwell et al. (cited in Dejene et al., 2018) are oriented along these lines.

The studies carried out applying this questionnaire coincide in identifying two main teaching approaches (Monroy, González-Geraldo et al., 2015): one focused on the transmission of information by the teacher (Information Transmission Teacher-Focused approach, ITTF) and another focused on the conceptual change among the students (Conceptual Change/Student-Focused approach CCSF), although there are degrees or intermediate categories (Soler et al., 2018). The first of these two main approaches is based on direct teaching by the teacher by way of masterclasses in order to transmit knowledge in a direct way, thereby making the teacher the main source of information and activity within the classroom. Thus, this approach is related with behavioral pedagogy (Dejene et al., 2018). In the second approach, which is anchored in behaviouralism, the student learns by doing and experimenting rather than by depending on the knowledge and experience of teachers to transmit knowledge.

The approach adopted by the teacher may have an influence on the way in which students learn and on their

observable results, as a teaching approach focused on the teacher is associated with superficial learning, whereas a student-based approach is related more with in-depth learning (Monroy, Hernández-Pina et al., 2015; Trigwell & Prosser, 2004).

One of the conclusions of Trigwell and Prosser's (2004) study highlighted the existence of certain variables in the context of teaching work which could lead teachers to adopt one or another of these approaches. In this regard, the greater the teacher's perception that he/she was sustaining an appropriate burden of work, that he/she was working with a homogeneous group of pupils without a very high level but with a sufficient level of knowledge and that he/she had a good grasp of the contents being taught, the more inclined he/she was to adopt an approach focused on the students' conceptual change. On the contrary, when a lack of commitment on the part of the pupils was noticed, along with a lack of mastery of the contents being taught, the probabilities of adopting the transmission of information approach focused on the teacher were greater.

Teacher Training and History Education

In recent years, research on history education has undergone a continual increase, constituting half of the scientific output on the teaching of the social sciences (Gómez & López-Facal, 2020). The results of these publications provide teachers with sufficient information in order to be able to renew epistemological and methodological aspects relating to the teaching and learning of history in such a way as to stop conceiving it as a set of closed knowledge which can only be memorized as a canonized narrative (Gómez Carrasco et al., 2017; Monte-Sano et al., 2014; Wineburg, 2001).

Some authors have stressed that the teaching practices experienced have a noticeable influence on teachers' conceptions in the methodological processes of teaching and learning (Martínez et al., 2009). In this regard, research such as that by Gómez Carrasco et al. (2020) on trainee secondary education teachers, and Gómez et al. (2021) with future primary education teachers regarding their memories of history classes points toward the fact that the majority of future teachers recognize that they have learned fundamentally by way of traditional strategies and techniques in which information transmitted by the teacher and/or the textbook was of primary importance and the contents had to be retained in the memory as a finished product. These future teachers also expressed their intention of implementing more active and innovative methodologies in the classroom in order to achieve integrated learning favoring social knowledge.

The consequences which can be extracted from different recent studies focusing on alternative practices by teachers (de Groot-Reuvekamp et al., 2018a, 2018b, 2019; Rodríguez-Medina et al., 2020; van Straaten et al., 2018), stress the importance in teacher training of the improvement of teaching knowledge, skills, and competencies relating to the

spheres of methodology and epistemology (Barnes et al., 2017; Floden, 2015).

Although the use of the ATI has expanded in recent years, the research proposed here would help to mitigate a research shortcoming which exists in our country regarding the teaching approaches of trainee teachers, specifically in the fields of geography and history. As Monroy, Hernández-Pina et al. (2015) have stated, it has hardly been employed in Spain for university teachers (González-Geraldo, 2010; Jiménez Hernández et al., 2020) or primary teachers (Hernández-Pina et al., 2012; Maquilón et al., 2016), and only rarely for secondary school teachers or trainee secondary school teachers (Monroy, 2013).

Ultimately, what is stated above justifies the need for this research, which focuses on revealing the teaching approaches of trainee history teachers, with the aim of improving their teaching skills in terms of methodology and their epistemological approach to this subject.

The Present Study

As has been stated in different studies, approaches to teaching are dynamic and depend on the context (Prosser & Trigwell, 2006; Stes, Coertjens et al., 2010a), given that the approach adopted in each situation is the result of the interaction between the teacher and the framework in which it is put into practice. Therefore, in practice, it is possible to observe teachers who prefer the items which characterize or define one approach, while not rejecting those which belong to the other approach. In this way, the teacher/teaching and student/learning approaches are profiles in which a clear pre-eminence of one approach is not observed and the use of mixed methodologies is evident (Hernández-Pina et al., 2012; Yunga-Godoy et al., 2016).

Divergent actions can be observed depending on different subjects. Some studies suggest that science teachers adopt approaches focusing on the teacher in their classes (ITT), whereas teachers of the humanities tend toward more student-based postures (CCS) (Lindblom-Ylänne et al., 2006; Lueddeke, 2003; Singer, 1996). Apart from these generalizations, it is complicated to determine the existence of clear profiles in teachers' preferred teaching approaches (Monroy, 2013).

The objective of this study is to analyze the teaching approaches of trainee history teachers in Spain. The following specific objectives are proposed:

- To analyze the reliability and validity data of the ATI questionnaire in trainee history teachers in Spain.
- To describe the teaching approaches manifested by the trainee teachers and the differences which exist according to sex and prior training.
- To analyze the response profiles and their differences with regard to sex and prior training.

Method

Approach

An experimental quantitative design was employed with data being gathered via a questionnaire with a Likert-type scale (1–5). This type of design was selected due to its capacity for providing answers to problems both in descriptive terms and in relation to variables when the information is gathered in a systematic manner, thereby guaranteeing the rigor of the data obtained (Hernández & Maquilón, 2010). Designs using surveys are extremely common in the field of education as they can be applied to multiple problems and make it possible to collect data about a large number of variables (Sapsford & Jupp, 2006).

Procedure

The procedure designed for the research and the data collection tools were evaluated positively by the Ethics Committee of the University of Murcia. An informed consent protocol was designed for the students and families of those participating in the research. Following prior contact with the coordinators and teachers of the master's degree in geography and history teacher training, a questionnaire was sent via a link to the universities which had agreed to participate: Murcia, Alicante, Valencia, Jaume I, Barcelona, La Rioja, Zaragoza, Oviedo, Basque Country, Santiago de Compostela, Complutense University of Madrid, Autonomous University of Madrid, Valladolid, Extremadura, Castilla-La Mancha, Huelva, Seville, Córdoba, Málaga, Almería, Jaén, and Granada. Participation in this research included 70% of the universities offering a master's degree in geography and history teacher training in Spain.

Participants

Six hundred forty-six students of master's degrees in geography and history teacher training from 22 different universities took part in the study, of whom 358 were men (55.41%) and 280 women (43.34%). As far as age is concerned, 51.7% were aged between 18 and 24 and 37.92% between 25 and 34, while 7.58% were over 35 years of age. As regards their prior training, 97.05% (627) of the participants had begun the master's degree in teacher training after concluding their degree, with more than half having studied history. Only 10% of the participants had completed any prior training regarding educational innovation.

The Data Collection Tool

A version of the ATI reviewed by Trigwell et al. (2005) was used in its most recent adaptation (22 items) translated by Monroy, Hernández-Pina et al. (2015).

Data Analysis

The analytical process was performed in four phases. In the first of them, the reliability of the measures was estimated (internal consistency, reliability of the individual indicators, and reliability of the construct). In the second phase, an exploratory factor analysis (EFA) was carried out on the matrix of polychoric correlations between the items (Hair et al., 2010). In the third phase, evidence of convergent and discriminant validity was analyzed by way of a confirmatory factor analysis. In the fourth phase, a hierarchical cluster analysis was carried out in order to verify the presence of possible groups and, finally, to ascertain the differences between these groups by way of an inferential analysis (ANOVA and Student's *t*).

The estimated fit of the model was verified via TLI (Tucker–Lewis Index) and CFI (Comparative Fit Index) values and via the root mean square error of approximation (RMSEA). CFI and TLI indices higher than .90 indicate acceptable degrees of fit, while those higher than .95 are considered to be good (Hu & Bentler, 1999). RMSEA values equal to or lower than .08 would be acceptable and those lower than .05 would be good (Browne & Cudeck, 1992; Hu & Bentler, 1999). R 3.6.3 (R Core Team, 2020) software was used for the analysis.

Results

Reliability

In this study, the method of internal consistency was employed based on Cronbach's ordinal alpha (Gadermann et al., 2012), making it possible to estimate the reliability of a measurement tool composed by a set of items, on a 5-point Likert-type scale, with the aim of measuring the same theoretical dimension. As a general criterion, the coefficient should be greater than 0.70 (George & Mallery, 2011). In the case of the ATI questionnaire, an overall alpha ordinal coefficient of $\alpha = .78$ was obtained, which can be considered to be acceptable.

Other authors propose the omega coefficient (McDonald, 1999), as this is not affected by the number of items, by the number of response alternatives or by the proportion of the variance of the test (Ventura-León & Caycho-Rodríguez, 2017). The omega coefficient is based on factor loadings, which are the weighted sum of the standardized variables. As a general criterion, coefficients greater than 0.70 are considered acceptable. In our case, the overall McDonald omega coefficient for the scale is $\omega = .79$, which is considered to be acceptable.

Exploratory Factor Analysis

After verifying the fit of the data for the factor analysis by way of the Kaiser Meyer Olkin (KMO) test and Bartlett's test of sphericity (KMO=0.85; 95% CI [0.835–0.912]; Bartlett's

test of sphericity, $\chi^2[190]=2726.3$; $p < .001$), an optimized parallel analysis was carried out (Timmerman & Lorenzo-Seva, 2011). Following these prior verifications, the optimized parallel analysis on 1,000 random replies obtained an optimum solution of two factors which explain 58.17% of the common variance (Table 1). These results grouped the items into two factors which correspond to the theoretical constructs previously proposed by the ATI. However, item 12 does not reach the minimum saturation of 0.3 (McDonald, 1985) in either of the two factors.

Confirmatory Factor Analysis

Subsequently, a confirmatory factor analysis was carried out in order to verify the internal structure of the scale and to review the fit of item 12 (Table 2). First of all, the structure of the ATI proposed by Trigwell et al. (2005) was analyzed. After separating the two scales, the reliability was reviewed, obtaining suitable results (for the CCS scale, an ordinal alpha of $\alpha = .87$ and $\omega = .87$). In the case of the ITT scale an ordinal alpha of $\alpha = .72$; and $\omega = .74$ was obtained. The fit of this model is acceptable ($\chi^2[169]=674.68$, $p < .001$; RMSEA=.070; CFI=.936; TLI=.928). However, item 12 was eliminated due to the fact that the saturation on both factors was lower than 0.3.

With the readjustment of the model, the indices improved considerably ($\chi^2[151]=478.93$, $p < .001$; RMSEA=.059; CFI=.957; TLI=.951). In the case of the reliability, for the CCS scale, an ordinal alpha value of $\alpha = .87$ and $\omega = .87$ was obtained. In the case of the ITT scale, the ordinal alpha values improved ($\alpha = .74$ and $\omega = .75$). Figure 1 shows the standardized estimations of the model. The correlation between the two models is both low and negative ($-.17$). There is no continuous single bipolar between the subject-based approach and the pupil-based approach. The preference for one approach over the other works as a combination of two different factors which are not very dependent on each other, in such a way that it is possible to observe individuals who prefer the items of one factor but do not reject the items of the other factor.

Items 8 (“Debates and discussions should be planned and promoted in the class sessions”) and 13 (“The pupils must be encouraged to discuss their changes of opinion and of understanding of history”) are those which contribute most to the CCS factor. Both are related with the creation of debates, discussion, and the questioning of previously-held ideas. In the case of the ITT subscale, items 2 (“In order to evaluate pupils, they should be asked to describe all the contents of history which correspond to the specific objectives and which they have to respond to in their test”) and 18 (“The way of teaching history focuses on transmitting my knowledge to the pupils”) are those which contribute most to the factor. That is to say, they are the items related with the transmission of the necessary knowledge for students to be able to pass the subject of history.

Table 1. Exploratory Factor Analysis. Saturations, Communalities, and Explained Variation.

Item	Factor 1. CCSF	F1	F2	h ²
3	The teacher should dialog with the pupils on the issues being studied	0.589	0.100	0.558
5	Part of the time should be reserved so that the pupils can discuss concepts and key ideas of history among themselves	0.723	0.043	0.755
7	The pupils must be encouraged to restructure their prior knowledge so that they can develop a new way of thinking about history	0.619	0.086	0.575
8	Debates and discussions should be planned and promoted in the class sessions	0.770	0.030	0.761
13	The pupils must be encouraged to discuss their changes of opinion and changes in the way they understand history	0.804	0.110	0.940
14	A large part of the time dedicated to the teaching of history should be used to question the pupils' ideas	0.424	0.176	0.467
16	I understand the teaching of history as a way of helping pupils to develop new ways of thinking about the issues studied	0.674	0.144	0.673
17	When teaching history, it is important to supervise any changes in understanding experienced by the pupils in relation to the issues studied	0.701	0.096	0.768
19	The teaching of this subject should help pupils to question their own understanding of history	0.706	0.009	0.895
20	The teaching of history should include helping pupils to find their own learning resources	0.634	0.080	0.605
Proper value = 5.03; Explained common variance = 38.17%; $\alpha = .87$; $\omega = .87$				
Item	Factor 2. ITTF	F1	F2	h ²
1	It is recommended that pupils focus their study of history on what their teacher provides them with	0.151	0.366	0.381
2	In order to evaluate pupils, they should be asked to describe all the contents of history which correspond to the specific objectives and which they have to respond to in their test	0.291	0.525	0.592
4	In the teaching of history, the most important thing is to present pupils with extremely complete information	0.042	0.540	0.562
6	History classes should focus on delivering information available in texts and key readings	0.131	0.480	0.559
9	The purpose of history classes is to help pupils pass their tests	0.134	0.533	0.494
10	Pupils must be provided with a good set of notes for them to learn history	0.112	0.486	0.459
11	Students must be provided with the information they need to pass the History course	0.124	0.584	0.711
12	It is important to respond to any question on history which pupils may ask	0.210	0.299	0.418
15	The model of history teaching should focus on a good presentation of the information to the pupils	0.017	0.609	0.731
18	The way of teaching history focuses on transmitting my knowledge to the pupils	0.295	0.543	0.545
Proper value = 2.91; Explained common variance = 20%; $\alpha = .72$; $\omega = .74$				

The composite reliability (CR) analysis of each latent variable provides an indicator of the reliability of the construct. In both cases the CR was greater than 0.70 ($CR_{CCS} = 0.88$; $CR_{ITTF} = 0.74$). Thus, it can be concluded that the indicators of both subscales, considered as a whole, are a reliable measure of the construct.

The evidence of discriminant validity shows that each of the constructs analyzed is unique and different from other constructs. In order to verify whether there is evidence of discriminant validity, three approaches have been employed (Hair et al., 2010). First of all, the correlation between both factors has been fixed at 1 and the fit of the resulting model has been compared with that of the original model. The results show that this model is significantly better than the model in which the correlation between the factors has been fixed at 1 ($\Delta\chi^2[1] = 860.9, p < .001$). Secondly, the confidence interval testing (Anderson & Gerbing, 1988) has shown that

the confidence interval of the correlation between the factors does not contain 1 ($\rho_{CCS-ITTF} = -.171 [-.159 \text{ to } -.183]$; $SE = .012$). Thirdly, it has been shown that the HTMT ratio (Henseler et al., 2014) of correlations between the indicators of different factors (*heterotrait-heteromethod* correlations—HT) between the correlations of the indicators of the same factor (*monotrait-heteromethod* correlations—MT) is less than .09 ($HT/MT = .225$).

Descriptive and Inferential Analysis

As can be observed in Table 3, the item scored most highly by the group of students participating in the research was that stating that “*The teacher should dialog with the pupils on the issues being studied*” (Item 3), regarding which 95.80% of the responses showed the agreement of the future teachers with this action. In second place, 93% of the students agreed

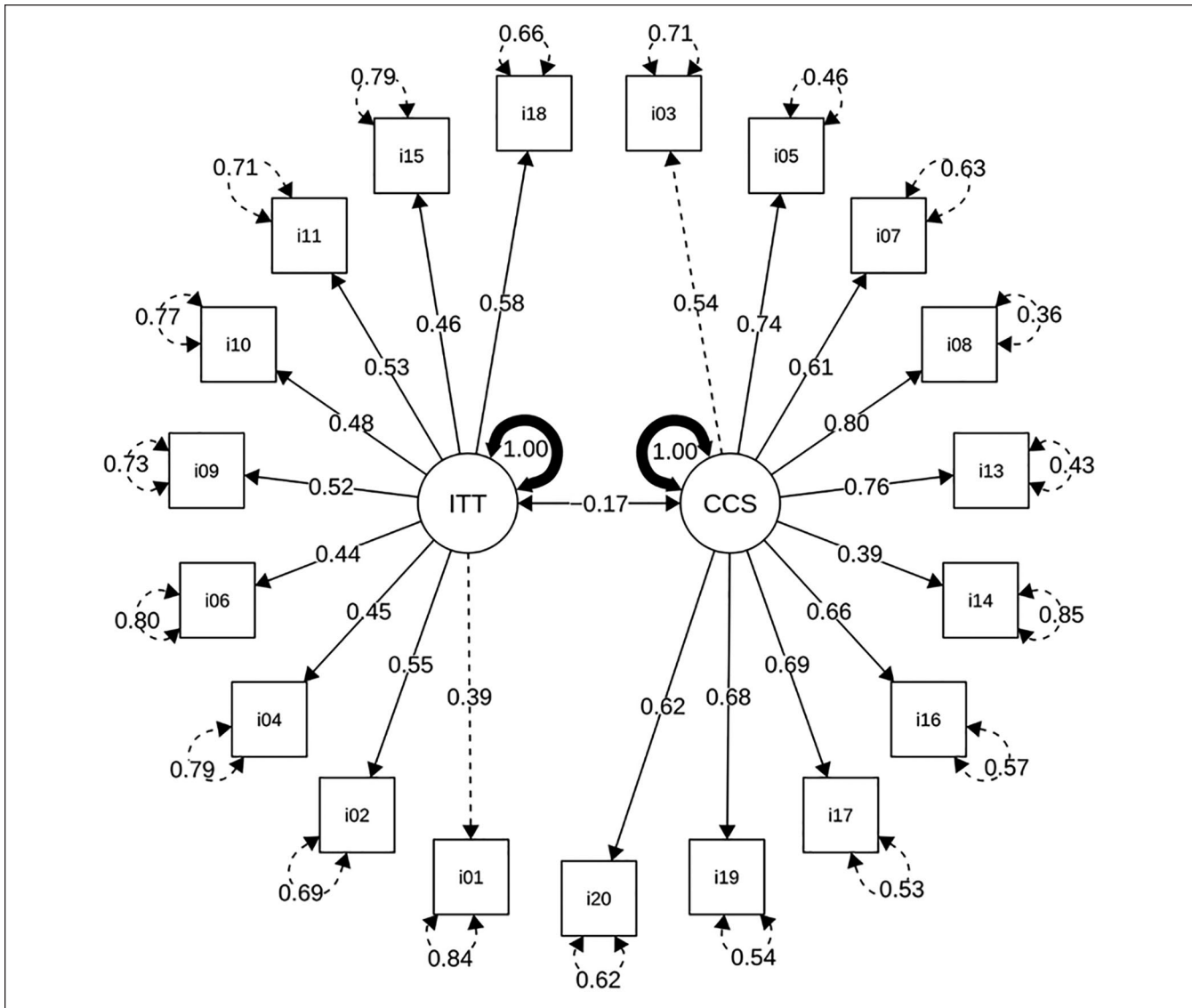

Figure 1. CFA model of two correlated factors.

Table 2. Comparison of the Fit of the Estimated Models.

Model	χ^2 (df)	$\Delta\chi^2$ (Δdf)	RMSEA	Δ RMSEA	CFI	Δ CFI	TLI	Δ TLI
Model 1	674.78 (169)	—	.070	—	.936	—	.928	—
Model 2	478.93 (151)	195.85 (18)	.059	.011	.957	.021	.951	.023

that “Debates and discussions should be planned and promoted in the class sessions” (Item 8). In third place, 92.4% of the trainee teachers considered that “Part of the time should be reserved so that the pupils can discuss concepts and key ideas of history among themselves.” Therefore, it can be concluded that the best-valued items belong to the CCS approach, linked with pedagogical actions which focus on the students and their participation in educational processes.

On the other hand, the items which have received a negative evaluation lie within the ITT approach, focused on the teacher, with Item 18 (*The way of teaching history focuses on transmitting my knowledge to the pupils*) standing out clearly with 52.60% of the trainee teachers disapproving of its application. In second place, with 42.90% of the responses expressing disagreement, is Item 2 (*In order to evaluate pupils, they should be asked to describe all the contents of history which correspond to the specific objectives and which*

Table 3. Descriptives From Block. 1.

Item	N	Min	Max	Mean	Median	%1	%2	%3	%4	%5	SD
1	642	1	5	2.95	3.00	5.14	23.70	45.50	22.70	2.96	0.89
2	645	1	5	2.68	3.00	11.00	31.90	37.50	17.50	2.02	0.95
3	644	1	5	4.67	5.00	0.31	0.31	3.57	23.80	72.00	0.59
4	644	1	5	3.19	3.00	4.04	20.70	36.80	28.90	9.63	1.00
5	644	1	5	4.49	5.00	0.31	2.33	4.97	32.50	59.90	0.73
6	642	1	5	2.94	3.00	8.10	25.20	36.80	24.10	5.76	1.02
7	642	1	5	4.36	5.00	0.62	3.11	8.39	35.60	52.30	0.81
8	642	1	5	4.53	5.00	0.62	0.78	5.61	30.50	62.50	0.70
9	642	1	5	2.88	3.00	14.30	24.00	31.30	20.60	9.81	1.18
10	643	1	5	3.26	3.00	2.95	17.60	39.70	30.00	9.80	0.96
11	643	1	5	3.68	4.00	2.18	8.24	28.80	41.10	19.80	0.95
12	643	1	5	4.15	4.00	1.71	4.67	16.30	31.10	46.20	0.97
13	645	1	5	4.53	5.00	0.31	0.46	7.13	30.50	61.60	0.68
14	643	1	5	3.52	4.00	4.35	9.02	33.40	36.70	16.50	1.01
15	645	1	5	3.56	4.00	1.40	12.20	30.20	41.10	15.00	0.94
16	644	1	5	4.20	4.00	0.78	2.17	13.50	43.80	39.80	0.81
17	639	1	5	4.21	4.00	0.31	1.41	10.60	52.00	35.70	0.71
18	644	1	5	2.47	2.00	16.90	35.70	33.90	10.40	3.11	0.99
19	644	1	5	4.43	5.00	0.93	0.31	7.30	37.90	53.60	0.72
20	645	1	5	4.39	5.00	0.46	1.24	8.22	38.80	51.30	0.73
Total	643.35	1	5	3.75	3.95	3.84	11.25	21.97	31.48	31.46	0.87

they have to respond to in their test). Finally, in third place, lies Item 9, which states that “The purpose of history classes is to help pupils pass their tests,” regarding which 38.30% of those surveyed expressed their disagreement.

In order to respond to the research objectives, first of all, an analysis of the differences according to sex was carried out via Student’s *t* tests. No statistically significant differences were found in the scores grouped in the CCS subscale according to the sex of the participants (male $M=4.29$; $SD=0.45$; female $M=4.38$; $SD=0.55$; $t(644)=1.43$; $p=.15$). However, there was a significant difference with the mean scores for the items of the ITTF subscale (male $M=3.14$; $SD=0.52$; female $M=2.93$; $SD=0.57$; $t[644]=4.8$; $p<.001$). Thus, the difference between sexes is not demonstrated so much in the opinions regarding the items relating to a pupil-based approach, but rather in the scores of the subject-based approach. The participating men presented a more favorable opinion of these items, as can be observed in Figure 2.

The inferential analysis regarding academic training was carried out in two phases. First of all, according to prior degree studies (in history, geography, history of art, etc.) and secondly, by differentiating the participants who had previously completed a teaching innovation course. Firstly, by way of an ANOVA test of one factor, no statistically significant differences were found regarding either the score, the CCS subscale ($F[76, 563]=.81$; $p=.86$) or the ITT subscale ($F[76, 563]=1.08$; $p=.30$). For the second case, the Student’s *t* test was used with the results indicating that there were no statistically significant differences in the CCS subscale among those who had not previously

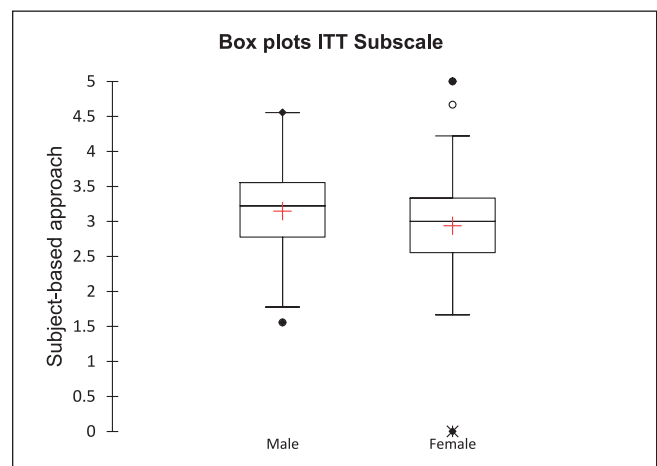
**Figure 2.** Representation of the ITT subscale according to sex.

completed an innovation course ($M=4.31$; $SD=0.48$) and those who had indeed received such training ($M=4.29$; $SD=0.62$; $t[644]=0.32$; $p=.74$). Neither were there significant differences in the ITT subscale among those who had not received innovation courses ($M=3.05$; $SD=0.55$) and those who had received such training ($M=3.05$; $SD=0.59$; $t[644]=-0.06$; $p=.95$).

Profiles of the Classes

An agglomerative hierarchical clustering (AHC) analysis was carried out according to the mean response to each of the

Table 4. Agglomerative Hierarchical Clustering.

Class	1	2	3
Objects	223	231	192
Sum of weights	223	231	192
Intraclass variance	0.515	0.187	0.145
Minimum distance to the centroid	0.047	0.038	0.036
Average distance to the centroid	0.546	0.386	0.339
Maximum distance to the centroid	4.880	1.087	1.227

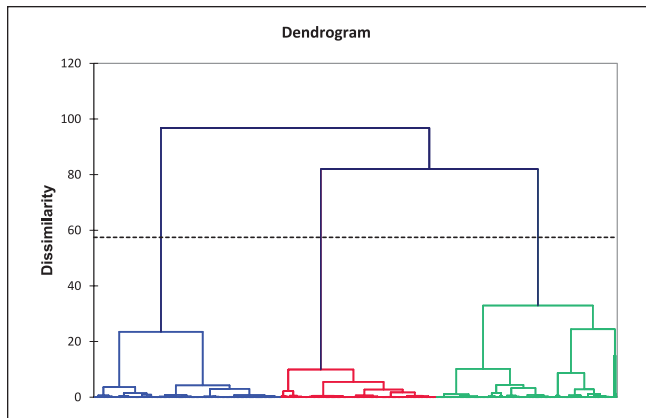
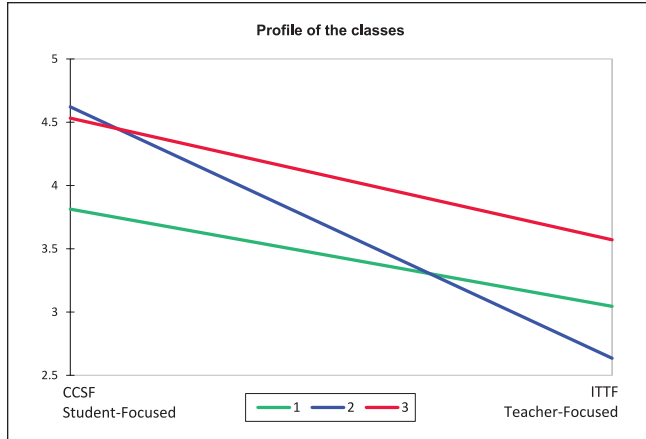
**Figure 3.** Dendrogram of the classes.**Figure 4.** Representation of the profiles of the classes.

subscales. The analysis revealed three classes, each of them with similar weighting (Table 4). The greatest intraclass variance and that which has the maximum distance with the centroid is Class 1, represented in green in the dendrogram (Figure 3) and in the profile of the classes (Figure 4). This class gives the lowest mean score to the CCS subscale and has the least difference between the mean score of the CCS subscale and the ITT subscale. Class 2, shown in blue, is at the other end of the dendrogram. This is the class which gives the highest score to the CCS subscale and shows the

greatest difference of scores between the subscales. Class 3, shown in red, is located in the center of the dendrogram and demonstrates an intermediate behavior.

A one factor analysis of variance was carried out in order to verify whether there are significant differences between classes. This was carried out with the mean scores of both subscales. Statistically significant differences were found ($F[2, 643]=361.8; p < .0001$) in both the CCS subscale and the ITT subscale ($F[2, 643]=274.19; p < .0001$).

The Tukey (HSD) post hoc test was performed in order to verify the differences between the categories (Table 5) in each of the subscales. There are significant differences in the CCS subscale among all of the classes, mainly between Class 1 and the rest ($p < .0001$), while the difference between Classes 2 and 3 is smaller ($p = .02$).

There are also significant differences in the ITT subscale among all of the classes. The differences of the classes in the ITT subscale are greater ($p < .001$) among all of the classes, as can be observed in Table 6. While Class 2 is that which gives a lower score to the ITT subscale, Class 3 is that which attributes the highest score to this subscale.

Differences among the classes regarding the prior academic training of the students and sex have been verified via the chi-squared test. With regard to academic training, there are no significant differences according to prior undergraduate studies ($\chi^2[76]=153.42; p = .4$). Neither are there significant differences among the classes depending on whether the participant has completed a prior teaching innovation course ($\chi^2[1]=.04; p = .9$). On the other hand, however, there are significant differences according to the sex of the participant ($\chi^2[2]=23.67; p < .001$). The association coefficients show a direct positive relationship which ranges from low to moderate (Table 7).

As can be observed in Figure 5, the differences according to sex arise, above all, in Classes 2 and 3. The female participants are found mainly in Class 2 (that which scores the CCS subscale more highly and awards the ITT scale a lower score). In this class, female participants outnumber males, whereas in class 3, which scores the ITT scale more highly, there are double the proportion of males to females.

Discussion and Conclusions

The main objective of this study is to analyze the teaching approaches of future secondary education teachers in the speciality of geography and history in Spain. The analysis of the results obtained make it possible to establish conclusions mainly according to sex. In response to the three specific objectives, the analysis of the reliability and validity data of the ATI questionnaire showed suitable results. Overall, the revised ATI questionnaire gave an alpha ordinal coefficient of .78, and a McDonald omega coefficient of .79, which are acceptable values for both cases. The option of eliminating Item 12 from the analysis was considered as it did not fit

Table 5. Differences Between the Classes According to the Score on the CCS Subscale.

Contrast	Difference	Standardized difference	Critical value	Pr > Dif	Significance
2 versus 1	0.808	24.840	2.349	<0.0001	Yes
2 versus 3	0.089	2.627	2.349	0.024	Yes
3 versus 1	0.719	21.080	2.349	<0.0001	Yes
Critical value of Tukey's D:			3.322		

Table 6. Differences Among the Classes According to the Score on the ITT Subscale.

Contrast	Difference	Standardized difference	Critical value	Pr > Dif	Significance
3 versus 2	0.936	23.413	2.349	<0.0001	Yes
3 versus 1	0.526	13.063	2.349	<0.0001	Yes
1 versus 2	0.409	10.657	2.349	<0.0001	Yes
Critical value of Tukey's D:			3.322		

Table 7. Association Coefficients According to Sex and Class.

Coefficient	Value
Pearson's Phi	0.191
Contingency coefficient	0.188
Cramér's V	0.191

correctly within the ITT subscale. This situation was attributed to a misunderstanding on the part of the participants in the study. The confirmatory factor analysis showed the existence of two theoretical constructs which coincide with the two approaches proposed in the questionnaire. The evidence of discriminant validity shows that each of the constructs analyzed is unique and different from other constructs.

As far as the second objective is concerned, which aimed to define the teaching approaches of trainee teachers and the existing differences according to sex and prior training, no significant differences were detected in the scoring groups within the CCS subscale according to the sex of the participants. However, there were significant differences in the ITT subscale. Thus, the difference between sexes is not shown so much in the opinion of the items related to a student-based approach, but rather in the scoring of the subject-based approach, in which the male participants presented a more favorable opinion of these items.

Finally, regarding the third objective, which analyzed the response profiles and their differences with regard to sex and prior training, it is possible to state that female participants are situated in Class 2, which scores the CCS subscale more highly and awards a lower score to the ITT scale. On the other hand, male participants outnumber females by two to one in Class 3, which scores the ITT scale more highly. Therefore, there is a confirmation of the existence of significant differences with regard to the sex of future history teachers in secondary and Baccalaureate education in Spain.

According to some studies, although teachers' sex could have an influence on their way of teaching, there are no conclusive results in this regard (Monroy, 2013; Monroy, Hernández-Pina et al., 2015). Indeed, some studies have shown a discourse which defends the inexistence of a direct relationship between sex and different teaching approaches, as is the case of the studies by Lueddeke (2003) and Stes et al. (2008). However, several studies have shown that differences exist, with males proving more favorable to an approach focused on the subject than females, who prefer an orientation toward student involvement (Monroy, Hernández-Pina et al., 2015; Rosário et al., 2012; Singer, 1996).

As far as the present study is concerned, differences have been found according to sex. On the one hand, the men presented a more favorable opinion toward the items relating to a subject-based approach (ITT) compared to the women, who presented statistically significant data in favor of the student-based approach (CCS).

As regards training, it should be pointed out that no statistically significant differences have been found regarding either the undergraduate or postgraduate studies of the participants or any training received on teaching innovation. The absence of statistically relevant results in this regard could be due to the lack of prior training of the students or due to its short duration (Monroy, 2013). Different studies have shown how teaching approaches evolve toward the CCS scale when this training exceeds a duration of 2 years (Postareff et al., 2007, 2008). In this regard, it is evident that changes occur in the long term. Therefore, the question should be asked if 1 year of training is sufficient in order to influence the teaching approaches of future teachers and, along the same lines, what experiences determine the establishment of one or another teaching approach among teachers.

In studies such as that by Monroy, Hernández-Pina et al. (2015), it has been observed how no differences have been noted according to sex in the pretest carried out on the

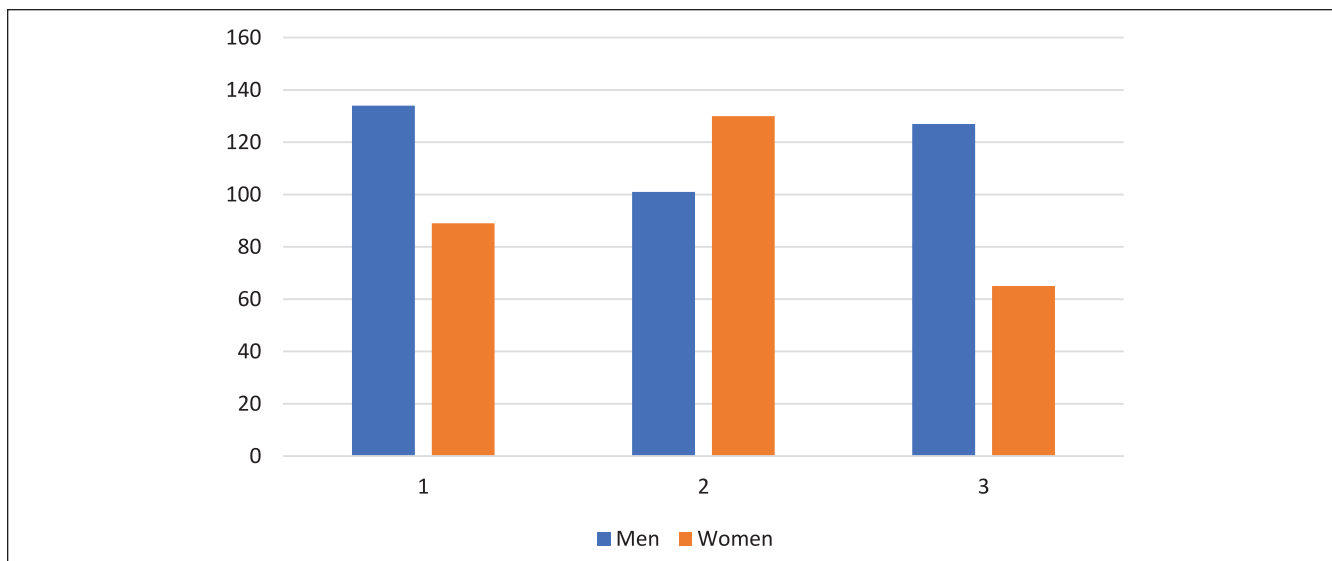

Figure 5. Number of scores by sex according to class.

students in training. However, in the posttest, after having completed the entire master's degree course in teacher training, women showed statistically significant differences in comparison to men, making it possible to conclude that women have a greater tendency toward adopting a student-based approach (CCS) than men, who are more prone to teaching with a subject-based approach (ITT). These results are in line with the study by Iqbal et al. (2019) in Pakistan, although not with that conducted by Han et al. (2015) in China, or with the work of Pauler-Kuppinger and Jucks (2018) with German academics.

Thus, based on recent research, it is difficult to conclusively predict whether the variable of sex has an influence or not on the teaching approach of current or future teachers. However, the results of this study can be added to those of other research relating to the context of Spain, in which, in addition to demonstrating tendencies closer to student-based teaching approaches, women also possess a more favorable opinion toward the use of innovative methods for the teaching of history, particularly the use of ICT resources and the mass media (Gómez Carrasco et al., 2020).

On the other hand, there is an abundance of studies on the use of the ATI questionnaire among university lecturers, although this is not the case in other stages of education, such as secondary education or initial training, independently of the subject in question. Therefore, limitations can be observed when establishing comparisons with similar cases in other subjects. However, one of the few studies which exist was carried out at the University of Vigo (Spain), where secondary education teachers undergoing their initial training, including the area of the social sciences, obtained higher scores in the conception of teaching understood as conceptual change and student-centered (Cid et al., 2012).

In relation to teachers' opinions, research has been carried out in which it has been proved that primary education teachers with positive emotions have a tendency toward teaching approaches more focused on the student, whereas negative emotions lead them to lean more toward approaches centered on the teacher and the transmission of knowledge (Chen, 2019).

Lastly, a similar case to the majority profile revealed in our research with regard to future history teachers in Spain (that is, a profile closer to a student-based approach) can be found among history teachers in Russia. In this case, teachers have been shown to be more flexible in the teaching of this subject, attributing more importance to history teaching of an innovative nature, particularly via the incorporation of more historical thinking skills in the classroom (Akhan, 2021). This is not the case, however, with Turkish teachers, who opt to teach history in a manner more focused on the study plan (Akhan, 2021).

Limitations and Educational Implications

As has been mentioned above, teaching approaches are dynamic and depend on the context. Therefore, the limitations of this study are related, first of all, with the territorial reality which defines our study, namely Spain. This fact leads us to exercise caution when generalizing results relating to the teaching approaches of trainee teachers, specifically in the case of history and the social sciences.

A second limitation relates to the subject in question. The results obtained in the case of trainee social sciences teachers may differ from the reality of those of other subjects, such as physics, mathematics, Spanish, etc. Finally, the level of education also makes it difficult to extrapolate the results as it

may be the case that in other stages of non-university education, such as early years and primary education, different data relating to the teaching approaches of trainee teachers may be found.

For the above reasons, it is desirable that in the near future more research be carried out regarding this issue in order to verify any possible changes. It is expected that new studies relating to the variable analyzed would make it possible to draw more solid conclusions, thus stimulating precise actions in the training context of higher education.

The educational and research implications of the results obtained can be approached from two sides. On the one hand, it is necessary to examine in more depth the cultural or training origin of these statistical differences according to sex in teaching approaches. This would imply research of a more qualitative nature and specific case studies, stressing the data yielded by these quantitative studies carried out with large samples. On the other hand, it is necessary to modify the training programs of history teachers, giving more importance to more didactic elements of the content to be taught. In spite of the effort made in this direction in some countries such as Spain, it is still necessary to examine the methodological elements in more depth, giving importance to active teaching strategies and innovative resources which allow for a student-based approach and a conceptual change.

Author Contributions

Cosme J. Gómez-Carrasco: Conceptualization; Methodology; Data curation; Formal analysis; Investigation; Supervision; Project administration; Funding acquisition; Visualization. Jairo Rodríguez-Medina: Conceptualization; Methodology; Data curation; Formal analysis; Writing-original draft; Writing - review & editing; Visualization. Álvaro Chaparro-Sainz: Conceptualization; Methodology; Investigation; Writing - original draft; Writing - review & editing; Funding acquisition; Visualization. José Monteagudo-Fernández: Conceptualization; Methodology; Writing - review & editing; Investigation; Writing - original draft; Visualization.

Declaration of Conflicting Interests

The author(s) declared no potential conflicts of interest with respect to the research, authorship, and/or publication of this article.

Funding

The author(s) disclosed receipt of the following financial support for the research, authorship, and/or publication of this article: This research was funded by the “Spanish Ministry for Science, Innovation and Universities. Secretary of State for Universities, Research, Development and Innovation”, grant number PGC2018-094491-B-C33; by the “Seneca Foundation. Regional Agency for Science and Technology”, grant number 20638/JLI/18; by the research project “HistoryLab for European Civic Engagement, grant number 2020-1-ES01-KA226-HE-095430, funded by the ERASMUS+ KA226 and by the “Spanish Ministry for Science and Innovation”, grant number PID2020-113453RB-I00. We would like to thank the above.

ORCID iDs

Jairo Rodríguez-Medina  <https://orcid.org/0000-0002-6466-5525>
 Álvaro Chaparro-Sainz  <https://orcid.org/0000-0002-4118-9394>

References

- Akhan, O. (2021). History teaching approaches preferred by Turkish and Russian history teachers. *World Journal of Education, 11*(1), 62–74. <https://doi.org/10.5430/wje.v11n1p62>
- Anderson, J. C., & Gerbing, D. W. (1988). Structural equation modeling in practice: A review and recommended two-step approach. *Psychological Bulletin, 103*(3), 411–423. <https://doi.org/10.1037/0033-2909.103.3.411>
- Barnes, N., Fives, H., & Dacey, C. M. (2017). U.S. Teachers’ conceptions of the purposes of assessment. *Teaching and Teacher Education, 65*, 107–116. <https://doi.org/10.1016/j.tate.2017.02.017>
- Browne, M. W. & Cudeck, R. (1992). Alternative ways of assessing model fit. *Sociological Methods and Research, 21*, 230–258. <https://doi.org/10.1177/0049124192021002005>
- Chen, J. (2019). Exploring the impact of teacher emotions on their approaches to teaching: A structural equation modelling approach. *British Journal of Educational Psychology, 89*(1), 57–74. <https://doi.org/10.1111/bjep.12220>
- Cid, A., Sarmiento, J. A., & Pérez, A. (2012). Las concepciones sobre la enseñanza de los estudiantes que realizaron el CAP y el Máster de Educación Secundaria en la Universidad de Vigo. *Revista de Investigación en Educación, 10*(1), 100–114.
- de Groot-Reuvekamp, M., Ros, A., & van Boxtel, C. (2018a). Improving elementary school students’ understanding of historical time: Effects of teaching with “Timewise”. *Theory & Research in Social Education, 46*(1), 35–67. <https://doi.org/10.1080/00933104.2017.1357058>
- de Groot-Reuvekamp, M., Ros, A., & van Boxtel, C. (2018b). A successful professional development program in history: What matters? *Teaching and Teacher Education, 75*, 290–301. <https://doi.org/10.1016/j.tate.2018.07.005>
- de Groot-Reuvekamp, M., Ros, A., & van Boxtel, C. (2019). ‘Everything was black and white . . .’: ‘Primary school pupils’ naive reasoning while situating historical phenomena in time. *Education, 47*(1), 18–33. <https://doi.org/10.1080/03004279.2017.1385642>
- Dejene, W., Bishaw, A., & Dagnaw, A. (2018). Preservice teachers’ approaches to learning and their teaching approach preferences: Secondary teacher education program in focus. *Cogent Education, 5*(1), 1502396. <https://doi.org/10.1080/2331186x.2018.1502396>
- Ender, T. (2019). Counter-narratives as resistance: Creating critical social studies spaces with communities. *The Journal of Social Studies Research, 43*(2), 133–143. <https://doi.org/10.1016/j.jssr.2018.11.002>
- Floden, R. (2015). Learning what research says about teacher preparation. In M. J. Feuer, A. I. Berman, & R. C. Atkinson (Eds.), *Past as prologue: The national academy of education at 50. Members reflect* (pp. 279–284). National Academy of Education.
- Gadermann, A. M., Guhn, M., & Zumbo, B. D. (2012). Estimating ordinal reliability for Likert-type and ordinal item response

- data: A conceptual, empirical, and practical guide. *Practical Assessment, Research & Evaluation*, 17(3), 1–14.
- George, D., & Mallery, P. (2011). *IBM SPSS statistics 19 step by step: A simple guide and reference*. Pearson.
- Gómez Carrasco, C. J., Chaparro Sainz, Felices de la Fuente, M D M, & Cózar Gutiérrez, R. (2020). Estrategias metodológicas y uso de recursos digitales para la enseñanza de la historia: análisis de recuerdos y opiniones del profesorado en formación inicial. *Aula Abierta*, 49(1), 65–74. <https://doi.org/10.17811/rifie.49.1.2020.65-74>
- Gómez Carrasco, C. J., Rodríguez Pérez, R. A., & Mirete Ruiz, A. B. (2017). Percepción de la enseñanza de la historia y concepciones epistemológicas. Una investigación con futuros maestros. *Revista Complutense de Educación*, 29(1), 237–250. <https://doi.org/10.5209/rced.52233>
- Gómez, C. J., & López-Facal, R. (2020). Educación histórica: Qué se ha investigado y qué se investiga. *Íber: Didáctica de las Ciencias Sociales, Geografía e Historia*, 100, 15–21.
- Gómez, C. J., Rodríguez, R. A., & Mirete, A. B. (2018). Percepción de la enseñanza de la historia y concepciones epistemológicas. Una investigación con futuros maestros. *Revista Complutense de Educación*, 29(1), 237–250. <http://dx.doi.org/10.5209/RCED.52233>.
- González-Geraldo, J. L. (2010). *Optimización de procesos educativos en el E.E.E.S* [Thesis doctoral]. Universidad de Castilla-La Mancha.
- Han, J., Yin, H., & Wang, W. (2015). Exploring the relationship between goal orientations for teaching of tertiary teachers and their teaching approaches in China. *Asia Pacific Education Review*, 16(4), 537–547. <https://doi.org/10.1007/s12564-015-9392-7>
- Hair, J. F., Black, W. C., Babin, B. J., & Anderson, R. E. (2010). *Multivariate data analysis* (7th ed.). Upper Saddle River, NJ: Pearson Prentice Hall.
- Henseler, J., Dijkstra, T. K., Sarstedt, M., Ringle, C. M., Diamantopoulos, A., Straub, D. W., Ketchen, D. J. Jr, Hair, J. F., Hult, G. T. M. & Calantone, R. J. (2014). Common beliefs and reality about PLS: comments on Rönkkö & Evermann (2013). *Organizational Research Methods*, 17(2), 182–209.
- Hernández, F., & Maquilón, J. J. (2010). Introducción a los diseños de investigación educativa. In En S. Nieto (Ed.), (Coords.) *Principios, métodos y técnicas para la investigación educativa* (pp. 110–126). Madrid: Dykinson.
- Hernández-Pina, F., Maquilón, J. J., & Monroy, F. (2012). Estudio de los enfoques de enseñanza de profesores de educación primaria. *Profesorado. Revista de Currículum y Formación del Profesorado*, 16(1), 61–77.
- Hu, L. T., & Bentler, P. M. (1999). Cutoff criteria for fit indexes in covariance structure analysis: Conventional criteria versus new alternatives. *Structural Equation Modeling*, 6, 1–55.
- Iqbal, T., Saeed, A., & Akhter, M. (2019). A study of university teachers' approaches to teaching at undergraduate level in Punjab, Pakistan. *Bulletin of Education and Research*, 41(1), 147–162.
- Jiménez Hernández, D., González Ortiz, J. J., & Tornel Abellán, M. (2020). Metodologías activas en la universidad y su relación con los enfoques de enseñanza. *Profesorado. Revista de Currículum y Formación de Profesorado*, 24(1), 76–94. <https://doi.org/10.30827/profesorado.v24i1.8173>
- König, J., Ligtvoet, R., Klemenz, S., & Rothland, M. (2017). Effects of opportunities to learn in teacher preparation on future teachers' general pedagogical knowledge: Analyzing program characteristics and outcomes. *Studies in Educational Evaluation*, 53, 122–133. <https://doi.org/10.1016/j.stueduc.2017.03.001>
- Lindblom-Ylänne, S., Trigwell, K., Nevgi, A., & Ashwin, P. (2006). How approaches to teaching are affected by discipline and teaching context. *Studies in Higher Education*, 31, 285–298. <https://doi.org/10.1080/03075070600680539>
- López-Facal, R. (2014). La LOMCE y la competencia histórica. *Ayer*, 94, 273–285. <https://doi.org/10.2307/24759536>
- Lueddeke, G. R. (2003). Professionalising teaching practice in higher education: A study of disciplinary variation and “teaching-scholarship”. *Studies in Higher Education*, 28(2), 213–228. <https://doi.org/10.1080/0307507032000058082>
- Maquilón, J. J., Sánchez, M., & Cuesta, J. D. (2016). Enseñar y aprender en las aulas de Educación Primaria. *Revista Electrónica de Investigación Educativa*, 18(2), 144–155. <http://redie.uabc.mx/redie/article/view/955>
- Martínez, N., Miralles, P., & Navarro, E. (2009). Análisis de cómo los docentes plantean el inicio de las clases, desde la perspectiva del alumnado. *Revista de Educación*, 348, 413–433.
- McDonald, R. P. (1985). *Factor analysis and related methods*. Hillsdale NJ: Erlbaum.
- McDonald, R. P. (1999). *Test theory: A unified treatment*. Mahwah: Lawrence Erlbaum Associates, Inc.
- Merchán, J. (2011). Práctica de enseñanza y gobierno de la clase. *Revista Española de Pedagogía*, LXIX(250), 521–535.
- Monroy, F. (2013). *Enfoques de enseñanza y de aprendizaje de los estudiantes del Máster Universitario en Formación del Profesorado de Educación Secundaria* [Doctoral thesis]. University of Murcia.
- Monroy, F., González-Geraldo, J. L., & Hernández-Pina, F. (2015). A psychometric analysis of the approaches to teaching inventory (ATI) and a proposal for a Spanish version (S-ATI-20). [análisis psicométrico del cuestionario approaches to teaching inventory (ATI) y propuesta en castellano (S-ATI-20)]. *Anales de Psicología/Annals of Psychology*, 31(1), 172–183. <https://doi.org/10.6018/analesps.31.1.190261>
- Monroy, F., Hernández-Pina, F., & Martínez Clares, P. (2015). Enfoques de enseñanza de estudiantes en formación pedagógica. Un estudio exploratorio = Approaches to teaching of trainee teachers, an exploratory analysis. *Revista Española de Orientación y Psicopedagogía (REOP)*, 25, 90–105. <https://doi.org/10.5944/reop.vol.25.num.3.2014.13860>
- Monte-Sano, C., De la Paz, S., & Felton, M. (2014). *Reading, thinking and writing about history. Teaching argument writing to diverse learners in the common core classroom, grades 6-12*. Teacher College Press.
- Nokes, J. D. (2017). Historical reading and writing in secondary school classrooms. In M. Carretero, S. Berger, & M. Grever (Eds.), *Palgrave Handbook of research in historical culture and education* (pp. 553–572). London: Palgrave.
- Pauler-Kuppinger, L., & Jucks, R. (2018). Out-of-Class instruction in higher education – Impact of approaches to teaching and discipline. *International Journal of Higher Education*, 7(2), 199–209. <https://doi.org/10.5430/ijhe.v7n2p199>
- Postareff, L., Lindblom-Ylänne, S., & Nevgi, A. (2007). The effect of pedagogical training on teaching in higher education.

- Teaching and Teacher Education*, 23, 557–571. <https://doi.org/10.1016/j.tate.2006.11.013>
- Postareff, L., Lindblom-Ylänne, S., & Nevgi, A. (2008). A follow-up study of the effect of pedagogical training on teaching in higher education. *Higher Education*, 56, 29–43. <https://doi.org/10.1007/s10734-007-9087-z>
- Prosser, M., & Trigwell, K. (2006). Confirmatory factor analysis of the approaches to teaching inventory. *British Journal of Educational Psychology*, 76, 405–419. <https://doi.org/10.1348/000709905x43571>
- R Core Team. (2020). *R: A Language and Environment for Statistical Computing*. Vienna, Austria: R Foundation for Statistical Computing. <https://www.R-project.org/>.
- Rodríguez-Medina, J., Gómez-Carrasco, C. J., Miralles-Martínez, P., & Aznar-Díaz, I. (2020). An evaluation of an intervention programme in teacher training for geography and history: A reliability and validity analysis. *Sustainability*, 12(8), 3124. <https://doi.org/10.3390/su12083124>
- Rosário, P., Núñez, J. C., Valle, A., Paiva, O., & Polydoro, S. (2012). Approaches to teaching in high school when considering contextual variables and Teacher Variables // Enfoques de enseñanza en Bachillerato en función de variables contextuales y del docente. *Revista de Psicodidáctica*, 18(1), 25–45. <https://doi.org/10.1387/revpsicodidact.6215>
- Sapsford, R., & Jupp, V. (2006). *Data collection and analysis*. (2nd ed.). SAGE Publications Ltd. <https://www.doi.org/10.4135/9781849208802>
- Singer, E. R. (1996). Espoused teaching paradigms of college faculty. *Research in Higher Education*, 37(6), 659–679. <https://doi.org/10.1007/bf01792951>
- Soler, M. G., Cárdenas, F. A., & Hernández-Pina, F. (2018). Enfoques de enseñanza y enfoques de aprendizaje: Perspectivas teóricas promisorias para el desarrollo de investigaciones en educación en ciencias. *Ciência & Educação (Bauru)*, 24(4), 993–1012. <https://doi.org/10.1590/1516-731320180040012>
- Stes, A., Coertjens, L., & Van Petegem, P. (2010a). Instructional development for teachers in higher education: Impact on teaching approach. *Higher Education*, 60, 187–204. <https://doi.org/10.1007/s10734-009-9294-x>
- Stes, A., De Maeyer, S., & Van Petegem, P. (2010b). Approaches to teaching in higher education: Validation of a Dutch version of the approaches to teaching inventory. *Learning Environments Research*, 13, 59–73. <https://doi.org/10.1007/s10984-009-9066-7>
- Stes, A., Gijbels, D., & Van Petegem, P. (2008). Student-focused approaches to teaching in relation to context and teacher characteristics. *Higher Education*, 55, 255–267. <https://doi.org/10.1007/s10734-007-9053-9>
- Timmerman, M. E., & Lorenzo-Seva, U. (2011). Dimensionality assessment of ordered polytomous items with parallel analysis. *Psychological Methods*, 16(2), 209–220. <https://doi.org/10.1037/a0023353>
- Trigwell, K., & Prosser, M. (1996). Congruence between intention and strategy in university science teachers' approaches to teaching. *Higher Education*, 32, 77–87. <https://doi.org/10.1007/bf00139219>
- Trigwell, K., & Prosser, M. (2004). Development and use of the approaches to teaching inventory. *Educational Psychology Review*, 16(4), 409–424. <https://doi.org/10.1007/s10648-004-0007-9>
- Trigwell, K., Prosser, M., & Ginns, P. (2005). Phenomenographic pedagogy and a revised Approaches to teaching inventory. *Higher Education Research & Development*, 24(4), 349–360. <https://doi.org/10.1080/07294360500284730>
- VanSledright, B. A. (2014). *Assessing historical thinking and understanding. Innovate designs for new standards*. Routledge.
- van Straaten, D., Wilschut, A., & Oostdam, R. (2018). Measuring students' appraisals of the relevance of history: The construction and validation of the relevance of history measurement scale (RHMS). *Studies In Educational Evaluation*, 56, 102–111. <https://doi.org/10.1016/j.stueduc.2017.12.002>
- Ventura-León, J. L., & Caycho-Rodríguez, T. (2017). El coeficiente Omega: Un método alternativo para la estimación de la confiabilidad. *Revista Latinoamericana de Ciencias Sociales, Niñez y Juventud*, 15(1), 625–627.
- Voet, M., & De Wever, B. (2020). How do teachers prioritize instructional goals? Using the theory of planned behavior to explain goal coverage. *Teaching and Teacher Education*, 89, 103005. <https://doi.org/10.1016/j.tate.2019.103005>
- Wineburg, S. (2001). *Historical thinking and other unnatural acts: Charting the future of teaching the past*. Temple University Press.
- Yunga-Godoy, D., Loaiza, M. I., Ramón-Jaramillo, L. N., & Puertas, L. (2016). Enfoques de la enseñanza en educación universitaria: Una exploración desde la perspectiva latinoamericana. *Profesorado. Revista de Currículum y Formación de Profesorado*, 20(3), 313–333.