

Limit analysis of planar steel frames, in-element plastic-hinge for uniformly distributed loads

M. Cacho-Pérez¹

ITAP, University of Valladolid, Paseo del Cauce 59, 47011, Valladolid, Spain

ARTICLE INFO

Keywords:

Plastic hinge
Planar steel frame
Collapse mechanism
Collapse load factor
Uniform loads

ABSTRACT

This work calculates the collapse load and collapse mechanism of 2D frames with slender structural members and uniformly distributed loads. The search for the collapse mechanism and the collapse load is carried out using step by step method: the load factor is increased and at each step the balance and compatibility equations must be satisfied that the value of the plastic moment is not exceeded in any section. It is verified that the results are different in the cases of point loads and uniform distributed loads, both from a qualitative and quantitative point of view.

1. Introduction

Steel framed structures show high non-linear behavior due to the plasticity of the material and the slenderness of its elements and are always the test bed for many areas of research. The initial development of many structural software is based on the study of this structural typology.

At the beginning of the study of the behavior of steel structures, the terminology plastic hinge was used to indicate a section (zero length) in which all its points reach the plastic regime. The term collapse mechanism was introduced by Kazinczy [1] in 1914 who was the first to investigate the reserve of plastic strength in a hyperstatic beam structure. In limit analysis it is common to adopt the plastic hinge approach to describe the inelasticity of the material [2].

Plastic behavior of structures in general and of framed structures in particular has been dealt with in many text books. The first reference to limit analysis came from Van den Broek [3], followed by the contributions of Baker and Heyman [4], Horne [5], Neal [6], and Hodge [7], all between 1955 and 1960. Considering only the bending effect, the other effects are neglected. By its simplicity, this approach is popularly applied to 2D steel frames.

The great momentum acquired by limit analysis was possible thanks to the rigorous establishment of the basic theorems, which was carried out by Gvozdev [8], in 1938. Basic theorems: static, kinematic and uniqueness, which give rise to kinematics or direct method based on the mechanism combination method [9–11].

There are two fundamental theorems: static and kinematic. This leads to two corresponding approaches: the static approach which gives rise to step-by-step methods; and the kinematic approach, which

gives rise to the so-called direct methods. The term “direct” means that the collapse load factor is found directly without calculating any intermediate loading state of the structures. Both the static method and the kinematic method have been continuously exploited and improved for more than 50 years until today, all of them have difficulties in solving large-scale problems, with many possible plastic hinges.

The classical formulation of the kinematic or direct method has important drawbacks from the point of view of its practical application: first, it is neither systematic nor general; and secondly, it requires testing possible collapse mechanisms, which even with few plastic hinges implies many possible collapse mechanisms that will have to be tested and verified. Recent methodologies [12] have reduced these drawbacks, as demonstrated for cases of simple structures.

On the other hand, step-by-step methods based on the matrix formulation are systematic but require employing a large number of degrees of freedom, since a solution of displacements is not always necessary in a plastic calculation problem. In a first analysis, it may be interesting to estimate the collapse mechanism and the maximum applicable load level. They are efficient for cases of concentrated load in the nodes of the structure [13,14], but not very precise for the analysis of structures with uniformly distributed loads. New non-matrix “vector” methodologies (requiring a smaller number of unknown quantities) have been efficient for these load cases, applied to simple cases [15].

In general, the plastic zone or plastic hinge approach is adopted to capture both the material inelasticity and the geometric non-linearity of a framed structure. In the plastic hinge approach, only one beam-column element per physical member can model the nonlinear properties of the structures. It leads to a significant reduction in calculation time.

E-mail address: mariano.cacho@uva.es.

¹ PhD. Mechanical Engineer.

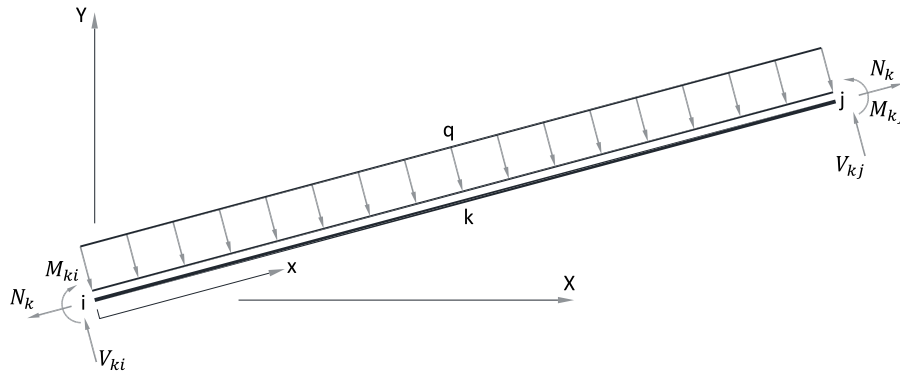

Fig. 1. Methodology. Beam/column element.

In the case of arbitrary loads, step-by-step methods are cumbersome and involve many difficulties, which is why the distributed load is usually replaced by concentrated loads at the nodes in statically equivalent theory [16]. Compared to other works [17] this work treats uniform loads as distributed loads and not as equivalent point loads. It was found that it is not equivalent and it is a topic that represents an interesting challenge. The main objective of this work is: to carry out the limit analysis of building structures, with many degrees of freedom and uniform distributed loads with a simple and precise methodology.

This paper has been organized as follows: after this brief introduction, the methodology is applied to various types of planar building frames. Finally, the main conclusions and contributions of the work are summarized.

2. Methodology

In this section, the calculation hypotheses are established, the obtaining of the equilibrium equations is explained and the resolution of the problem is proposed by means of step by step techniques [18,19].

2.1. Hypotheses

- The beams and columns are assumed to be slender rectilinear lines of constant section.
- They are assumed to be free of residual or initial stresses.
- Plastic collapse implies unlimited displacement at constant load, and the level of load that causes it is called the collapse load.
- The value of the maximum bending moment that the section can transmit is called plastic moment ($M_{p,k}$).
- When the bending moment reaches the value of the plastic moment, the rotation of the section where it occurs can increase indefinitely.
- The plastic moment depends on the material yielding stress and the cross-sectional area.
- The formation of each plastic hinge is supposed to take place in a sudden and concentrated way in the section where the bending moment reaches the value of the plastic moment.
- The hypothesis of small displacements and rotations of the sections of the structure at the moment of collapse is assumed; therefore, the accumulated rotations between beams or columns in the plastic hinges must also be small.

2.2. Equilibrium equations

To obtain the equations of equilibrium, the matrix method of analysis of beam/column structures is considered, but in its vector formulation [15,20]. The balance of each bar is considered as follows (see Fig. 1). The end forces are calculated and the force vector is formed:

$$f_k = \begin{pmatrix} N_{ki} \\ V_{ki} \\ M_{ki} \\ N_{kj} \\ V_{kj} \\ M_{kj} \end{pmatrix} = \begin{pmatrix} -N_k \\ qL_k + \frac{1}{L_k} \left(M_{kj} - M_{ki} - q\frac{L_k^2}{2} \right) \\ -M_{ki} \\ N_k \\ -\frac{1}{L_k} \left(M_{kj} - M_{ki} - q\frac{L_k^2}{2} \right) \\ M_{kj} \end{pmatrix} \quad (1)$$

where (N_{ki}, N_{kj}) are the axial forces, (V_{ki}, V_{kj}) are the shear forces, (M_{ki}, M_{kj}) are the bending moments at the ends of the beam/column (k) and being L_k the length of the structural member (k); the first subscript indicates the element bar (k) and the second superscript indicates the node (i, j), (q) is the transversal uniform distributed load. All magnitudes are expressed as functions of the axial force (N_k) and the values of the bending moments in both end sections (M_{ki}, M_{kj}) and the applied load (q).

The previous vector is expressed in the coordinates (x, y) of the beam/column, and must be expressed in a global coordinate system (X, Y) common to the structure, through the corresponding coordinate transformation ($T(\alpha)$):

$$F_k = T^T(\alpha) \cdot f_k \quad (2)$$

where (F_k) are the forces (and moment) at the ends of the bar k , expressed in a common system for all the members of the structure, and ($T^T(\alpha)$) indicates the operation of transposing rows and columns in the matrix ($T(\alpha)$) of change of coordinates.

Finally, the vector of internal forces (F_{int}) must be assembled. It balances the external loads (F_{ext}) applied at the nodes of the structure:

$$F_{int} = F_{ext} \quad (3)$$

In the case of point loads, it is known that the sections of the structure that are candidates for forming a possible plastic hinge are: the nodes (joints between beams/columns), the fixed supports, the section of application of the loads and section changes [21,22], and the total number of possible plastic hinges is called (npPH).

In the case of beams with distributed load, plastic hinges can additionally be formed in the intermediate sections of the beams with applied uniform distributed load. Logically, it is then necessary to carry out the corresponding checks from the bending moments calculated at the nodes of the structure [23,24].

It is important to bear in mind that if a plastic hinge is produced in an intermediate section, then its location at the beam (given by parameter x_k) can be modified during the plasticizing process, up until the formation of the collapse mechanism.

$$M_k = \frac{M_{kj} - M_{ki}}{L_k} x_k + M_{ki} + \frac{\lambda q L_k x_k}{2} - \frac{\lambda q x_k^2}{2} \quad (4)$$

$$x_k = \frac{\lambda q L_k^2 - 2M_{ki} + 2M_{kj}}{2\lambda q L_k}$$

where λ is the load factor, (M_k) is the maximum bending moment in the beam k and (x_k) is the section where the maximum value occurs.

2.3. Compatibility equations

From Eqs. (3), the rows associated with the reactions in the supports are eliminated. The resulting equations only depend on the axial forces and the bending moments in the beams/columns, and the applied loads. And the Virtual Works Principle (VWP) (see Annex A) is formulated as [21]:

$$0 = \sum_{k=1}^{nb} \left(\int_0^{L_k} M_k(x) \frac{\delta m_k(x)}{EI_k} dx + \delta m_{ki} \theta_{ki} + \delta m_{kj} \theta_{kj} \right) + \sum_k m_k \cdot \theta_k \quad (5)$$

$$m_k = \frac{(m_{kj} - m_{ki})}{L_k} x_k + m_{ki}$$

where nb is the number of beams and columns in the structure, $M_k(x)$ is the bending moment in the beams and columns of the structure, $\delta m_k(x)$ is the bending moment of the auxiliary or virtual problems, δm_{ki} is the virtual moment at node i of bar k , and θ_{ki} is the accumulated rotation in the plastic hinges [22].

From a mathematical point of view, the null space of matrix A (see Annex B) allows sets of values of linearly independent (virtual problems) to be obtained that, through the Virtual Works Principle (VWP), allow the calculation of the necessary compatibility equations to be systematized [23,24].

Finally, the steps in order to apply the methodology correctly is summarized:

- Step 1: all the data of the problem are defined, geometric and mechanical properties of the beams and columns, elastic and plastic properties of the material, supports and loads applied to the structure.
- Step 2: the internal forces vector of each beam/column is calculated.
- Step 3: vector of equivalent forces of the structure is assembled (balance equations at the structure nodes).
- Step 4: from the previous equations, the supports' equations are eliminated, resulting in the minimum number of equilibrium equations to solve the limit analysis problem.
- Step 5: next the Virtual Works Principle (VWP) is applied for each beam/column based on the equations indicated in annexes A and B, then the compatibility equations of the problem are obtained.
- Step 6: once all the equations are in place, the process of forming plastic hinges is systematized, step by step method, until the structure becomes a mechanism.
- Step 7: final, problem solved, the collapse mechanism and the associated collapse load factor are obtained, and all intermediate results during the loading and hinge formation process.

3. Numerical results and discussion

In this section, the methodology is applied to the study of five application problems.

3.1. Numerical data

The numerical data in common for all the problems are: $E = 3 \cdot 10^8$ kN/m²; $F = 500$ kN; $q_1 = 10$ kN/m; $q_2 = 5$ kN/m; where E is Young's module and q_1, q_2 are two uniformly distributed loads.

All the columns have the same mechanical and geometric properties, they are: $L_c = 3$ m; $M_{pc} = 1800$ kN m; $I_c = 54000$ cm⁴ where L_c is the length of the columns; M_{pc} is the columns plastic moment and column inertia moment.

All the beams have the same mechanical and geometric properties, they are: $L_b = 4$ m; $M_{pb} = 450$ kN m; $I_b = 6750$ cm⁴ where L_b is the length of the beams; M_{pb} is the beams plastic moment and beam inertia moment.

Table 1
3 × 4 frame. Collapse step by step.

Step	λ_i	$\frac{x_a}{L_b}$	Step	λ_i	$\frac{x_a}{L_b}$	Step	λ_i	$\frac{x_a}{L_b}$
1	1.0	–	11	1.4862	–	21	2.4344	0.4449
2	1.2916	–	12	1.5037	–	22	2.4401	0.4456
3	1.3100	–	13	2.2584	–	23	2.4440	0.4460
4	1.3149	–	14	2.2650	0.4246			
5	1.3686	–	15	2.2683	0.4250			
6	1.3742	–	16	2.2775	0.4261			
7	1.3797	–	17	2.2826	0.4268			
8	1.3816	–	18	2.3032	0.4292			
9	1.4007	–	19	2.4255	0.4437			
10	1.4588	–	20	2.4281	0.4442			

Table 2
3 × 4 frame. Collapse load factor.

	This work	Casciaro & Garcea [25]	CEPAO [26]	Difference
λ_c	2.4440	2.4612	2.4612	0.70%

Table 3
4 × 6 frame. Collapse load factor.

	This work	Casciaro & Garcea [25]	CEPAO [26]	Difference
λ_c	1.7796	1.8610	1.8610	4.57%

3.2. Problem 1

In this section, a 3 × 4 frame is solved, the base of four columns are fixed, concentrated loads and uniform distributed loads are applied (see Fig. 2).

The methodology outlined in Section 2 is applied using a Mathematica notebook that systematically solves the plastic problem. To do so, it first calculates the equilibrium equations and compatibility equations for this problem. Limit analysis steps are included in Table 1.

In Table 1 not only the successive values of the load factor are indicated but also the location of the internal plastic hinge a (bounded by x_a relative to L_b and measured from left to right in the beam element), see Fig. 2.

In this case, the collapse mechanism of the structure involves the formation of plastic hinges in sections show in Fig. 2, and the collapse load factor is in Table 2.

It is interesting to note that at the end of the structure loading process, all the internal hinges are formed in the same location in the corresponding beam $x = 0.4460 \cdot L_b$, logically due to the geometry and the support and load conditions of the structure.

3.3. Problem 2

In this section, this work methodology is used to solve a 4 × 6 planar frame with concentrated loads as well as uniform distributed loads. Fig. 3 not only shows the definition of the problem but also the plastic hinges that give rise to the collapse mechanism of the structure.

The Table 3 shows the numerical results and compares them with the indicated references. It is verified that there are not only quantitative but also qualitative differences, since the intermediate plastic hinges due to the distributed loads are not formed in the central section of the beam but approx for $x = 0.3508 \cdot L_b$.

3.4. Problem 3

The structure that is resolved in this section is a 5 × 9 planar frame, see Fig. 4. The collapse mechanism shows that the intermediate plastic hinge forms closer to the left end of the beam, in this case at a distance $x = 0.1914 \cdot L_b$ (see Table 4).

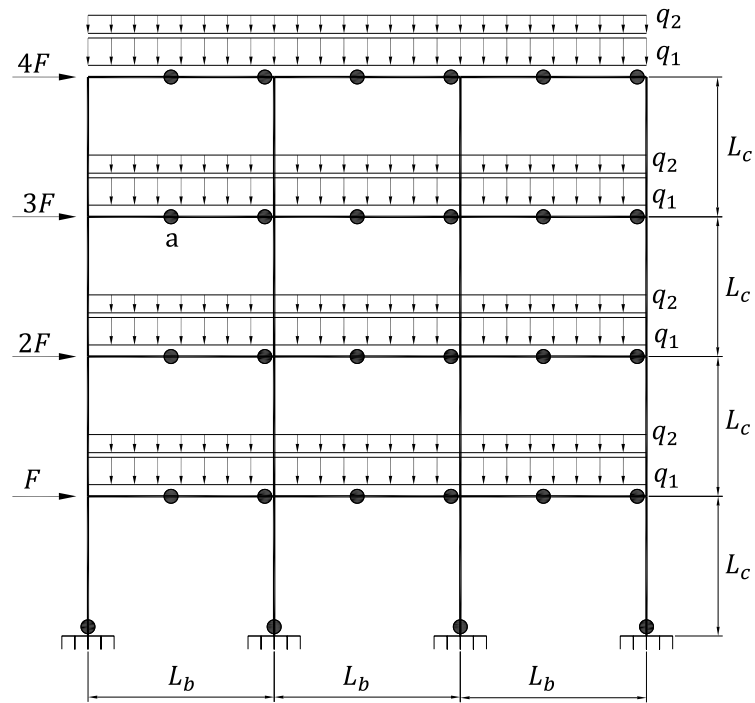

Fig. 2. 3×4 frame. Plastic hinges.

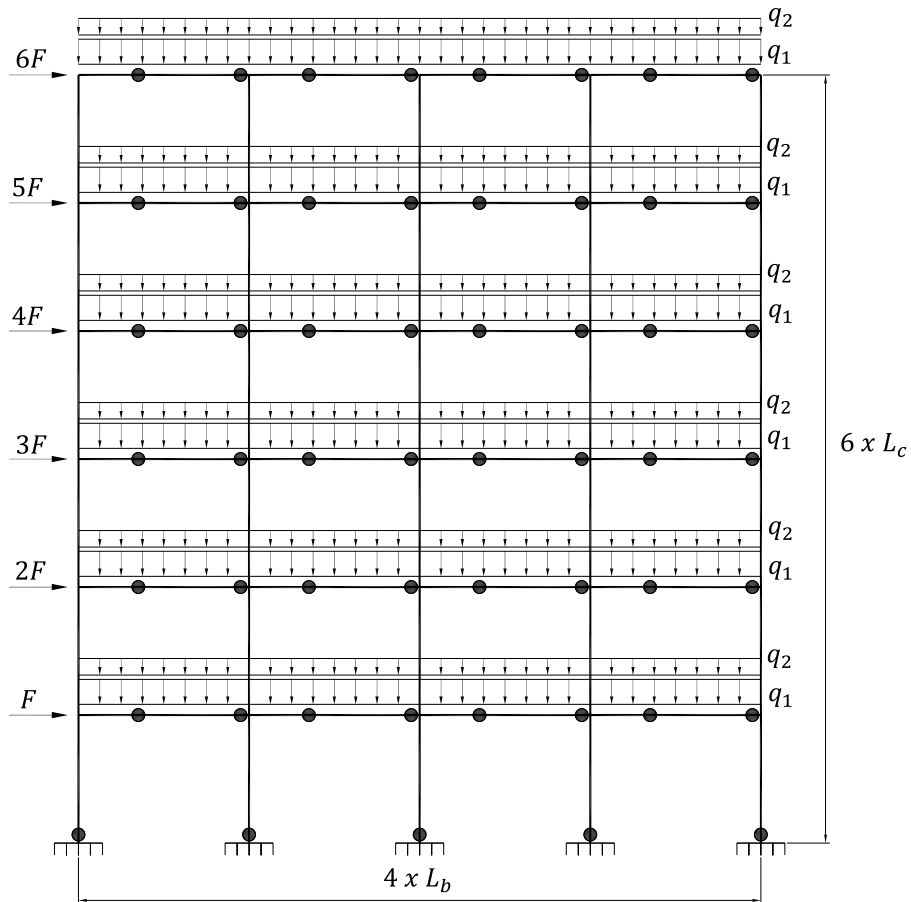

Fig. 3. 4×6 frame. Plastic hinges.

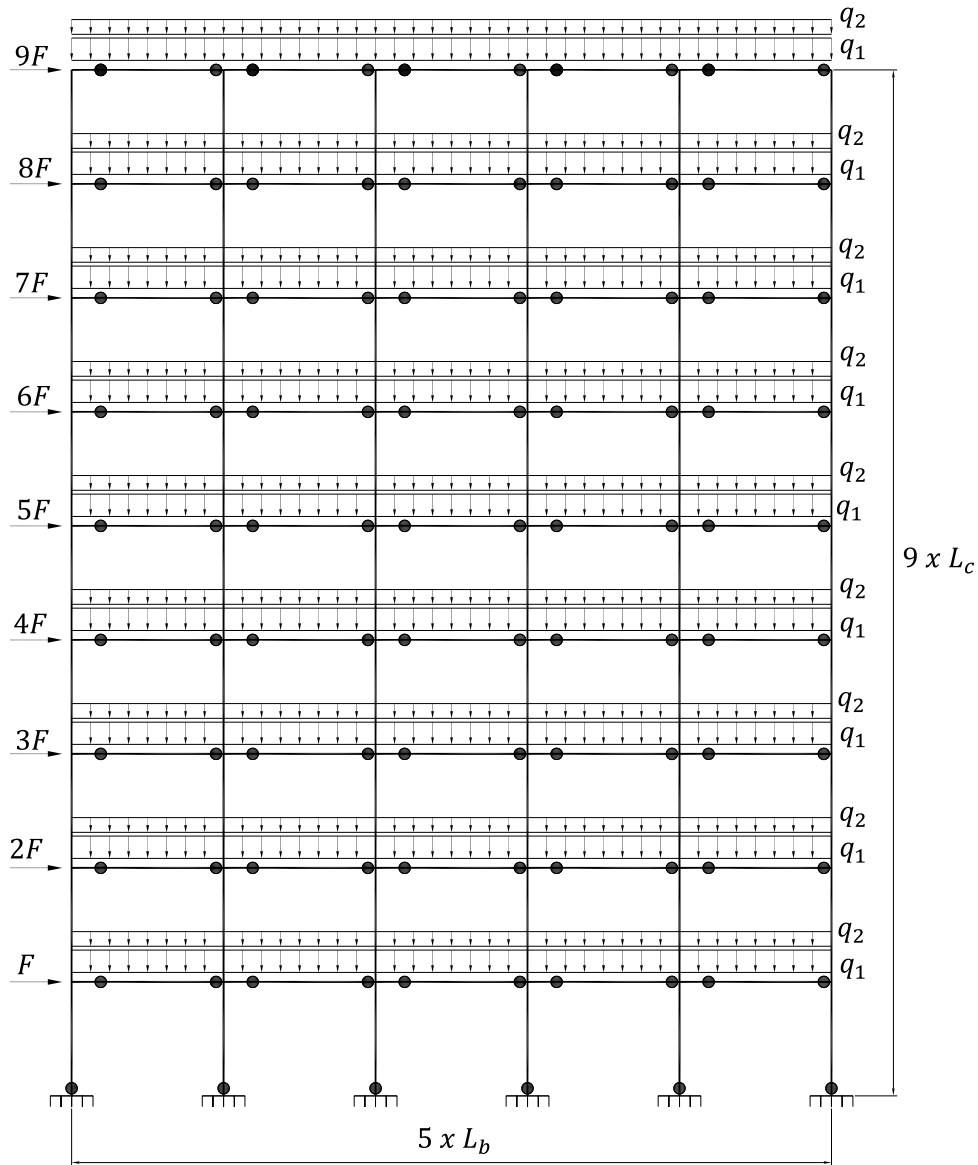

Fig. 4. 5 × 9 frame. Plastic hinges.

Table 4
5 × 9 frame. Collapse load factor.

	This work	Casciaro & Garcea [25]	CEPAO [26]	Difference
λ_c	1.1470	1.2000	1.2000	4.62%

3.5. Problem 4

The next 6 × 10 frame type is solved. Fig. 5 shows the problem definition and plastic hinges location for the collapse mechanism. The Table 5 includes the collapse load factor value.

And the intermediate plastic hinges due to the distributed loads are formed approx for $x = 0.1778 \cdot L_b$ relative to beam length.

3.6. Problem 5

The resolution of a 2 × 10 frame with point loads and distributed loads is considered in this section, see Fig. 6. Table 6 shows the numeric results where a difference of 12.33% is observed.

Table 5
6 × 10 frame. Collapse load factor.

	This work	Casciaro & Garcea [25]	CEPAO [26]	Difference
λ_c	1.1095	1.1532	1.1532	4.85%

Table 6
2 × 10 frame. Collapse load factor.

	This work	Casciaro & Garcea [25]	CEPAO [26]	Difference
λ_c	1.9822	2.0444	2.0444	12.33%

After applying the same methodology as in the previous section, a collapse load factor $\lambda_c = 1.9822$ is obtained and the intermediate plastic hinge forms at a distance $x = 0.3849 \cdot L_b$. The plastic collapse mechanism is formed that involves the formation of hinges as indicated in Fig. 6. One of the advantages of the methodology is that the uniform distributed loads case is solved using the same discretization of nodes and elements that for concentrated loads case.

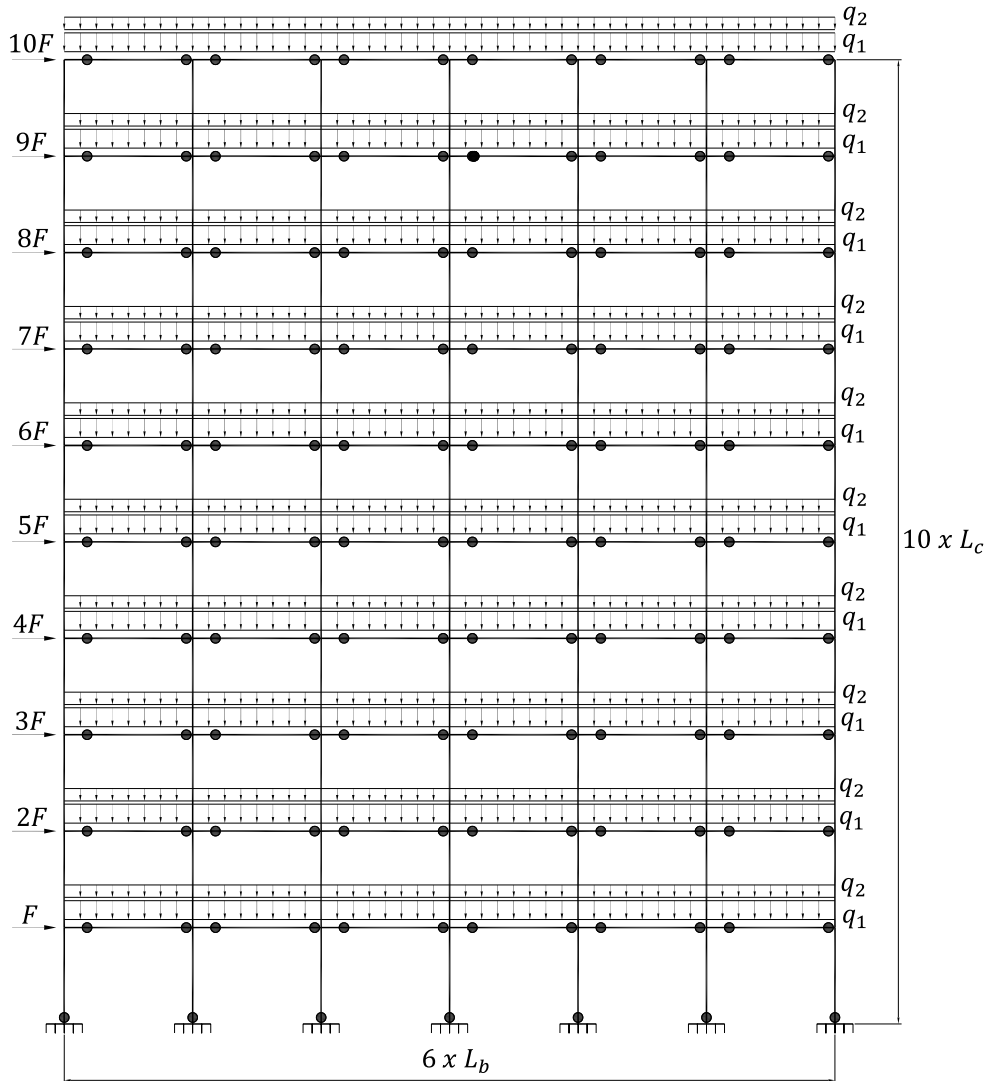

Fig. 5. 6 × 10 frame. Plastic hinges.

Step by step method allows the behavior of the structure to be known as the load increases. It facilitates the study of real cases, since more beams/columns and loads can be used with uniform distributed loads. And it is immediate to obtain the safety factor of the elastic-linear design.

4. Conclusions

The classic formulation for plastic methods of planar frames is very unsystematic. It is based on the Virtual Works Principle (VWP) and use equilibrium equations to find the structure’s collapse mechanism and requires using virtual problems in displacements (virtual mechanisms). Technique based on testing possible mechanisms until the collapse mechanism is found and it is much more complicated if it would had distributed loads.

However, this work applies the Virtual Works Principle (VWP) during the loading process. In order to avoid having to test possible mechanisms one by one, it leads directly to the collapse mechanism corresponding to the structure with given loads, geometry and boundary conditions.

Table 7

Collapse load factor (λ_c), comparative (problems 1 to 5).

Problem	This work	Casciaro & Garcea [25]	CEPAO [26]	Difference
1	2.4440	2.4612	2.4612	0.70%
2	1.7796	1.8610	1.8610	4.57%
3	1.1470	1.2000	1.2000	4.62%
4	1.1095	1.1532	1.1532	4.85%
5	1.9822	2.0444	2.0444	12.33%

This work systematizes the plastic analysis of the structure using a step by step vector method. It is applied to the study of flat frames of buildings, the limit analysis technique is applied with distributed loads (common in this type of structure). And the method presented in this work quickly provides the safety factor for a linear-elastic design of the structure under study.

Summary Table 7 shows that the results obtained here differ from those included in the references. It is proven that replacing some types of loads in the structure with others that are theoretically equivalent leads to different results. It is found that this difference is greater as

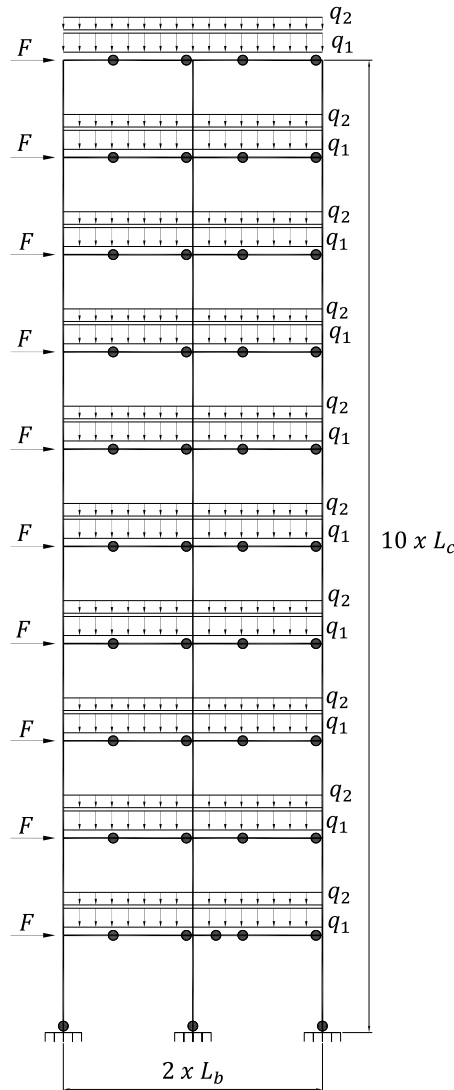

Fig. 6. 2 × 10 frame. Plastic hinges.

the complexity of the building increases and that it could also imply unsafe analyzes of the structure.

CRedit authorship contribution statement

M. Cacho-Pérez: Conceptualization, Investigation, Methodology, Software, Supervision, Validation, Visualization, Writing – original draft, Writing – review & editing.

Declaration of competing interest

The authors declare that they have no known competing financial interests or personal relationships that could have appeared to influence the work reported in this paper.

Data availability

No data was used for the research described in the article.

Acknowledgments

The author wishes to acknowledge the Department of Architectural Constructions, Terrain Engineering and Mechanics of Continuous Media and Theory of Structures of the University of Valladolid for help and resources provided to carry out this work.

Annex A. Compatibility equations (CEs)

The Virtual Works Principle (VWP) requires auxiliary problems in balance to be posed. By posing virtual problems with concentrated forces and moments, the calculation of the deformation energy can be systematized.

• Concentrated loads

If the structure of the problem of interest only has concentrated loads, the following deformation energy expression results for each beam:

$$\int_0^{L_k} M_k(x) \frac{\delta m_k(x)}{EI_k} dx = \frac{L_k}{6EI_k} (\delta m_{ki}(2M_{ki} + M_{kj}) + \delta m_{kj}(M_{ki} + 2M_{kj})) \tag{6}$$

• Uniform distributed load

If the structure beam is requested by uniform distributed load, the following expression is as follows:

$$\int_0^{L_k} M_k(x) \frac{\delta m_k(x)}{EI_k} dx = \frac{L_k}{6EI_k} (\delta m_{ki}(2M_{ki} + M_{kj}) + \delta m_{kj}(M_{ki} + 2M_{kj}) + \frac{q_y L_k^2}{4} (\delta m_{ki} + \delta m_{kj})) \tag{7}$$

where $M_k(x)$ are the moments of the problem of interest, $\delta m_k(x)$ are the moments of the virtual problem and δm_{ki} ; δm_{kj} , the bending moments at the end sections and q_y is the value of the uniform distributed load requested at the beam.

Annex B. Null space of a matrix

The solution sets of homogeneous linear systems provide an important source of vector spaces. Let A be an m by n matrix, and consider the homogeneous system:

$$A \cdot x = 0 \tag{8}$$

Since A is m by n , the set of all vectors x which satisfy this equation forms a subset of R^n (it clearly contains the zero vector). This subset is nonempty and forms a subspace of R^n , called the nullspace of the matrix A , and is denoted as $N(A)$.

Thus, the solution set of a homogeneous linear system forms a vector space. Note that if the system is not homogeneous, then the set of solutions is not a vector space, since the set will not contain the zero vector.

References

- [1] G.V. Kazinczy, Experiments with clamped end beams, *Betonszemle* 5 (1914) 68–71, 83–87, 101–104.
- [2] M. Saka, M. Hayalioglu, Optimum design of geometrically nonlinear elastic-plastic steel frames, *Comput. Struct.* 38 (3) (1991) 329–344, [http://dx.doi.org/10.1016/S0045-7949\(99\)00221-7](http://dx.doi.org/10.1016/S0045-7949(99)00221-7).
- [3] J. Van den Broek, *Theory of Limit Desig*, Wiley, 1948.
- [4] J. Baker, J. Heyman, *Plastic Design of Frames 1: Fundamentals*, Cambridge University Press, 1969, <http://dx.doi.org/10.1017/CBO9780511586514.002>.
- [5] M.R. Horne, Fundamental propositions in the plastic theory of structures, *J. Inst. Civ. Eng.* 6 (1950) <http://dx.doi.org/10.1680/IJOTL.1950.12895>.
- [6] B.G. Neal, *The Plastic Methods of Structural Analysis*, Chapman & Hall, 1985.
- [7] J. Hodge, G. Philip, The practical significance of limit analysis, *J. Aerosp. Sci.* 25 (11) (1958) 724–726, <http://dx.doi.org/10.2514/8.7861>.
- [8] A.A. Gvozdev, The determination of the value of the collapse load for statically indeterminate systems undergoing plastic deformation, *Int. J. Mech. Sci.* 1 (1960) 322–335, [http://dx.doi.org/10.1016/0020-7403\(60\)90051-5](http://dx.doi.org/10.1016/0020-7403(60)90051-5).

- [9] M. Doblaré, L. Gracia, *Plastic Analysis of Bar Structures*, Copycenter, 1988.
- [10] H.R. Dalmau, J. Vilardell, *Plastic Analysis of Structures: Introduction*, Ediciones UPC, 2003, <http://dx.doi.org/10.5821/ebook-9788483019894>.
- [11] G.R. Calborg, *Plastic Analysis of Bar Structures: Theory*, Universidad de Granada, 2008.
- [12] M. Cacho-Pérez, J. Gómez-Carretero, Plastic calculation of slender beam frames systematic method based on mechanism theory, *Structures* 34 (2021) 2840–2847, <http://dx.doi.org/10.1016/j.istruc.2021.09.033>.
- [13] A. Lorenzana, P.M. López-Reyes, E. Chica, J.M. Terán, M. Cacho-Pérez, A nonlinear model for the elastoplastic analysis of 2D frames accounting for damage, *J. Theoret. Appl. Mech.* 49 (2) (2011) 515–529.
- [14] V.L. Hoang, H. Nguyen, J.P. Jaspart, J.F. Démonceau, An overview of the plastic-hinge analysis of 3D steel frames, *Asia Pac. J. Comput. Eng.* (2015).
- [15] M. Cacho-Pérez, Sequential plastic method for 2D frames limit analysis, *Structures* 47 (2023) 1680–1690, <http://dx.doi.org/10.1016/j.istruc.2022.12.005>.
- [16] H. Van Long, N. Dang Hung, Limit and shakedown analysis of 3-D steel frames, *Eng. Struct.* 30 (7) (2008) 1895–1904, <http://dx.doi.org/10.1016/j.engstruct.2007.12.009>.
- [17] N. Dang Hung, CEPAO—an automatic program for rigid-plastic and elastic-plastic analysis and optimization of frame structures, *Eng. Struct.* 6 (1) (1984) 33–51, [http://dx.doi.org/10.1016/0141-0296\(84\)90060-9](http://dx.doi.org/10.1016/0141-0296(84)90060-9).
- [18] J. Lubliner, *Plasticity Theory*, Maxwell Macmillan International Editions, 1990.
- [19] J. Chakrabarty, *Theory of Plasticity*, Elsevier, 2006.
- [20] M. Cacho-Pérez, Limit analysis of planar steel frames with variable section type and arbitrary loads, *Int. J. Non-Linear Mech.* 162 (2024) 104718, <http://dx.doi.org/10.1016/j.ijnonlinmec.2024.104718>.
- [21] J. Richard-Liew, H. Chen, N. Shanmugam, W. Chen, Improved nonlinear hinge analysis of space frame structures, *Eng. Struct.* 22 (2000) 1324–1338, [http://dx.doi.org/10.1016/S0141-0296\(99\)00085-1](http://dx.doi.org/10.1016/S0141-0296(99)00085-1).
- [22] S. Kim, M. Kim, W. Chen, Improved refined plastic hinge analysis accounting for strain reversal, *Eng. Struct.* 20 (2000) 15–25, [http://dx.doi.org/10.1016/S0141-0296\(98\)00079-0](http://dx.doi.org/10.1016/S0141-0296(98)00079-0).
- [23] M. Cacho-Pérez, Plastic analysis, stability, and natural frequency of two-dimensional frames of variable section beams, *J. Eng. Mech.* 142 (3) (2016) [http://dx.doi.org/10.1061/\(ASCE\)EM.1943-7889.0000998](http://dx.doi.org/10.1061/(ASCE)EM.1943-7889.0000998).
- [24] M. Cacho-Pérez, *Numerical techniques for failure analysis of two-dimensional frames, including stability and vibration behaviour* (Ph.D. thesis), University of Valladolid. ProQuest Dissertations Publishing, 3489189, 2010.
- [25] R. Casciaro, G. Garcea, An iterative method for shakedown analysis, *Comput. Methods Appl. Mech. Engrg.* 191 (49) (2002) 5761–5792, [http://dx.doi.org/10.1016/S0045-7825\(02\)00496-6](http://dx.doi.org/10.1016/S0045-7825(02)00496-6).
- [26] V.L. Hoang, *Automatic plastic-hinge analysis and design of 3D steel frames*, 2008.